

# Kontaktstift ø8 mm

Einsatzbereich: - 923, 1-polig  
Crimp 50 mm<sup>2</sup>

TE Teile Nr.: 61-0162-023-000  
IC Ref. Nr.: 61.162.23

## Elektrische Werte

Bemessungsstrom 200 A\*  
Durchgangswiderstand < 110 µOhm

## Werkstoff

Kontakt Messing, versilbert

## Anschluss

Anschlussart/-bereich Crimp/ 50 mm<sup>2</sup>  
max. Litzenaußendurchmesser ø15 mm  
Abisolierlänge 18 mm  
Crimpeinstellungen sind individuell zu wählen

## Mechanische Werte

Steckzyklen 500

## Werkzeuge (nicht im Lieferumfang enthalten)

Crimpzangen-Set im Koffer, TE Teile Nr.: C0-0207-000-000  
komplett mit Crimpeinsätzen IC Ref. Nr.: C0.207.00

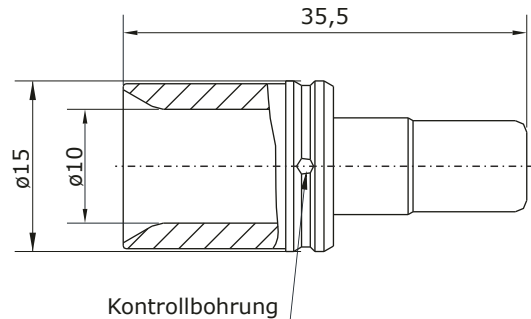
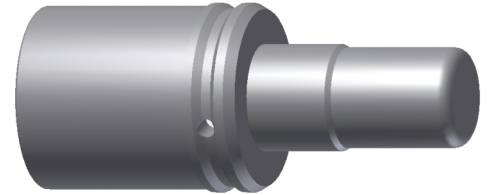

## Hauptabmessungen

Kontaktstift





# Contact Pin $\varnothing 8$ mm

for: - 923, 1-pin  
crimp 50 mm<sup>2</sup>

TE part number: 61-0162-023-000  
IC reference number: 61.162.23

### Electrical Data

rated current 200 A\*  
contact resistance < 110  $\mu$ Ohm

### Material

contact brass, silver plated

### Termination

cross-section crimp/ 50 mm<sup>2</sup>  
max. outer wire diameter  $\varnothing 15$  mm  
stripping length 18 mm  
crimp settings select individually

### Mechanical Data

mating cycles 500

### Tools (not part of product contents)

crimp tool set in case TE part no.: C0-0207-000-000  
complete with crimp insert IC ref. no.: C0.207.00

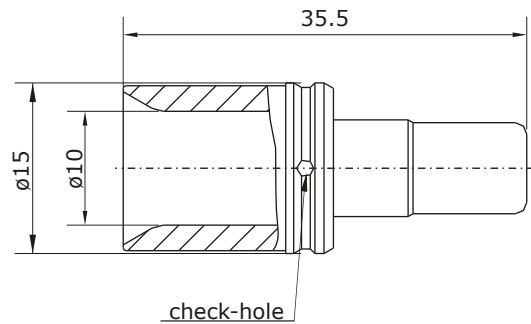
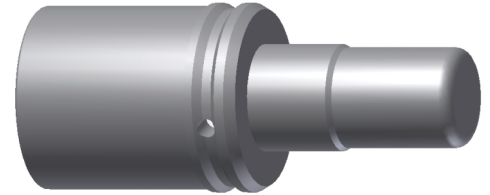

**Main Dimensions**  
contact pin

