

Emergency Product Change Notification

Replacement of Monolithic windows for CBT-90-UV

June 12, 2018

- Scope: the emergency PCN is applicable to certain UV products in production assembled using a monolithic “frame + window” component as described in the next slide.
- Proposed Change: Luminus is proposing to replace this monolithic component by discrete “Frame” + “Window” components. The proposed solution has been qualified to use for new UV products and only results in minor changes to the products that should be transparent to customers. These are explained in this presentation.
- At the same time, a lower thermal resistance die-attach material will be used. This material, already in use with other CBT-90 products, will lower Rth (junction-board) from 0.8 ° C/W to 0.45 ° C/W thus improving performance and lifetime. Product performance or reliability will not be adversely affected in any manner.

- Motivation: Luminus continues to experience unstable supply from our vendor of monolithic windows due to process complexity. This situation is impacting Luminus' ability to predictably deliver products ordered by customers. The proposed solution is being rolled out on new products and Luminus is proposing to retrofit existing/legacy products.
- Effective date: immediately (lead-time applies).

Current: Monolithic Window

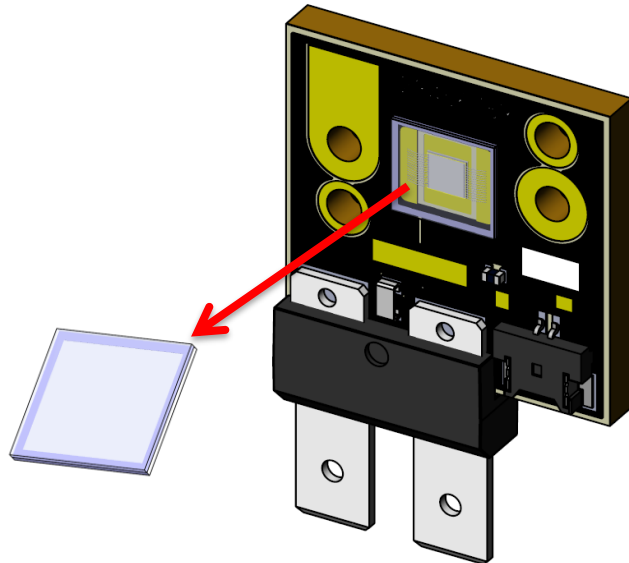

Proposed: Discrete Window/Frame

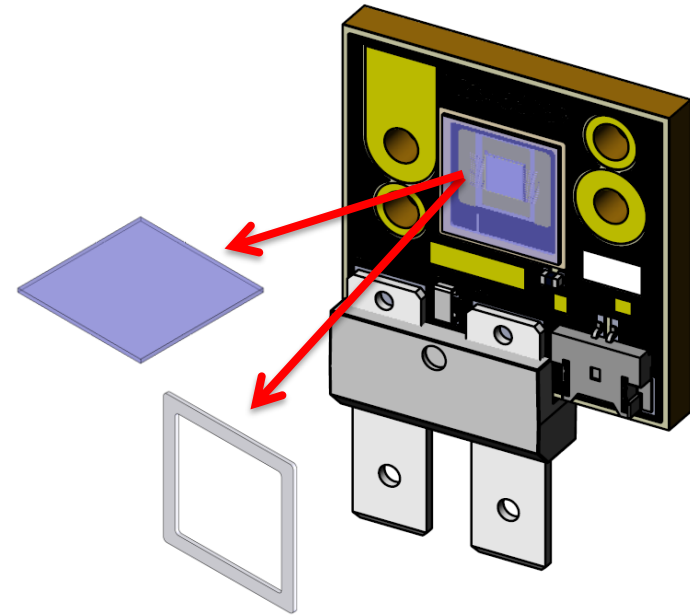

- Glass Vendor: same
- Window glass material: same
- Window glass thickness: same
- Window coating: same
- Transmission curve: same

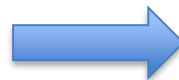

No
optical
impact

	Monolithic window	2-Piece Window
Glass thickness	0.30	0.30
Total thickness	0.635	0.58
Transmittance	98% min 340 - 450 nm 99% average 340 - 450 nm	95% min 400 - 420 nm 98% min 420 - 700 nm

Monolithic Window

Dimension: 9.00m x 7.97mm

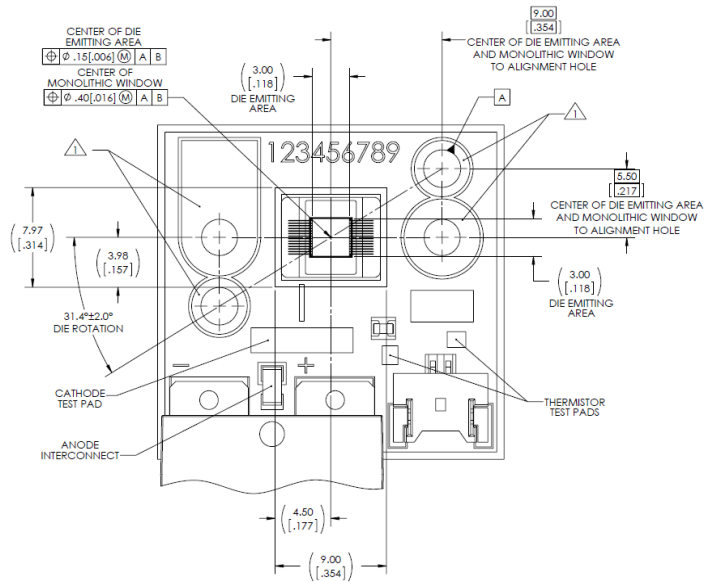

Discrete Window+Frame

Dimension: 10.0m x 10.0mm

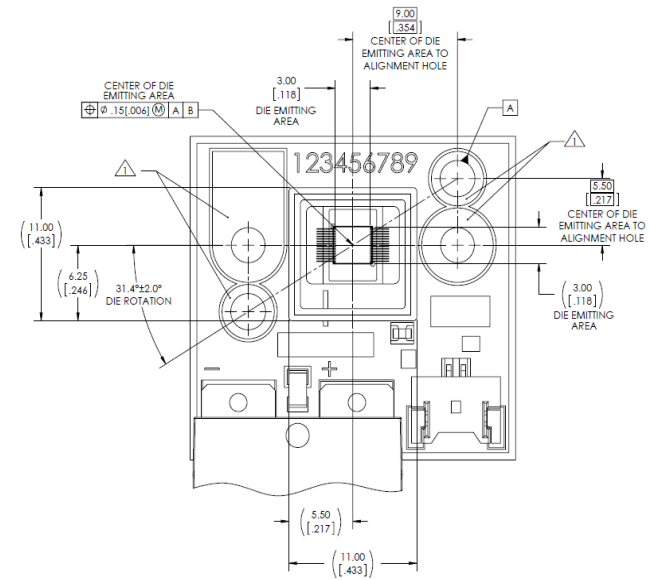

- Discrete window approach has minor differences in [XY] dimensional footprint
- Both options share same optical center placement with respect to datum
- Customers should confirm that this will not result in interference with surrounding tooling
- This is the only backwards compatibility concern with the discrete solution

Monolithic Window

Top of die emitting area to top of window: *0.61 mm*

Top of window to back of coreboard: *4.09 mm*

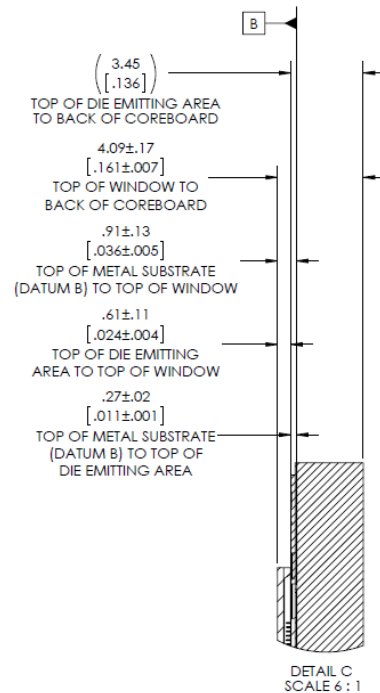

Discrete Window/Frame

Top of die emitting area to top of window: *0.65 mm*

Top of window to back of coreboard : *4.06 mm*

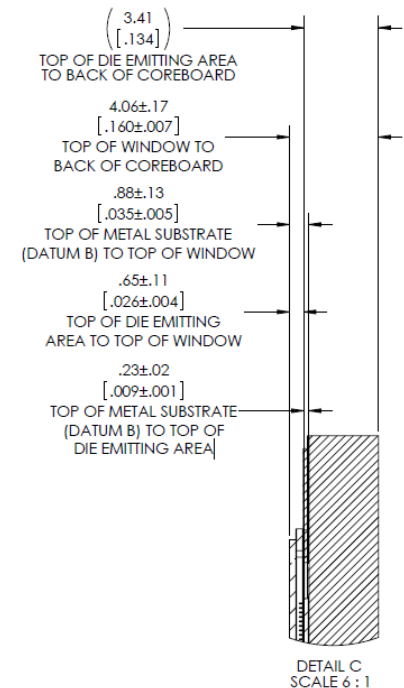

- Equivalent “Z-stack”: Window of Discrete option lower, ensuring no interference with surrounding tooling/optics
- As explained in slide 3, window element is identical for both approaches [thickness, material, AR coating] and made from same source glass sheets from same vendor.

- The proposed discrete frame + window passes strict reliability criteria and is considered qualified for production. Customers also benefit from a lower Rth (junction-board).
- Luminus is requesting customers to confirm that the minor difference in “XY” dimensions will not affect their design. If confirmed, Luminus is requesting approval for immediate transition to discrete window.
- Note: As mentioned in the product datasheet: Special design considerations must be observed for operation under 1 A. Please contact Luminus for further information.
- Luminus is confident that this transition will allow us to restore consistent and predictable delivery for our UV series, as expected by our customers.