

THIS COPY IS PROVIDED ON A RESTRICTED BASIS AND IS NOT TO BE USED IN ANY WAY DETRIMENTAL TO THE INTERESTS OF PANDUIT CORP.

NO WARRANTY, EXPRESSED OR IMPLIED IS MADE BY PANDUIT WITH RESPECT TO ADHESIVE BOND PERFORMANCE. AMONG OTHER THINGS, THE CONDITIONS UNDER WHICH THESE MOUNTS MAY BE APPLIED AND / OR THE SURFACE TO WHICH THEY MAY BE APPLIED ARE BEYOND PANDUIT'S CONTROL.

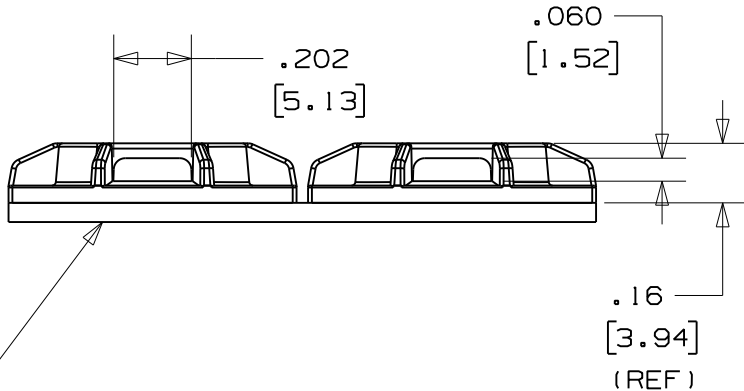
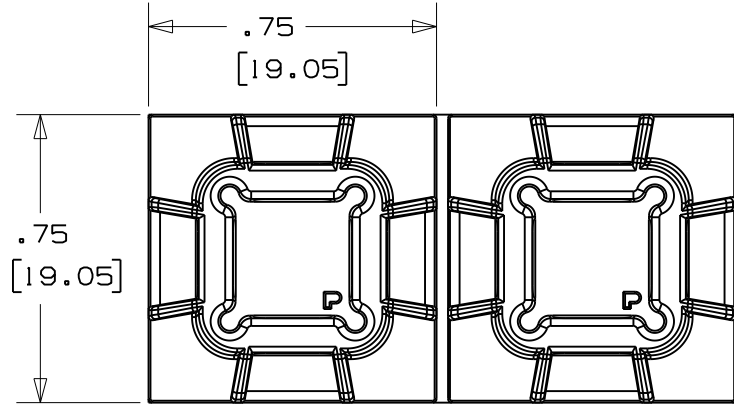

**ADHESIVE BACKING:**

- \*[ -A ] RUBBER BASED ADHESIVE PRESSURE SENSITIVE FOAM TAPE 0.04 (1.0) THICK WITH A PROTECTIVE LINER. MOUNT IS DESIGNED TO SUPPORT 0.28 lbs (127g) MAX. WEIGHT ON A CLEAN DRY SMOOTH SURFACE.
- \*[ -AT ] ACRYLIC BASED ADHESIVE PRESSURE SENSITIVE FOAM TAPE 0.04 (1.0) THICK WITH A PROTECTIVE LINER. MOUNT IS DESIGNED TO SUPPORT 0.28 lbs (127g) MAX. ON A CLEAN DRY SMOOTH SURFACE.
- \*[ -AV ] HIGH BOND ACRYLIC BASED ADHESIVE PRESSURE SENSITIVE FOAM TAPE 0.04 (1.0) THICK WITH A PROTECTIVE LINER. MOUNT IS DESIGNED TO SUPPORT 0.56 lbs (254g) MAX. ON A CLEAN DRY SMOOTH SURFACE.

PANDUIT PART NO. *	REC'M FASTENER	USE WITH THESE CABLE TIE CROSS SECTIONS	WEIGHT lbs / 100 (g) / pcs
SGABM20-A ABM20 PAM075NY-A	RUBBER ADHESIVE	M, I, SG100M, SG150I	0.142 (64.4)
SGABM20-AT ABM20B	ACRYLIC ADHESIVE		
SGABM20-AV	HIGH BOND ACRYLIC ADHESIVE		

**NOTES**

1. SEE CURRENT PRICE SHEET FOR PART NUMBER SUFFIX DESIGNATION FOR PACKAGE SIZE AND COLOR.
  2. PRODUCT IS SUPPLIED IN STRIPS OF TWO.
  3. [ -A ] MOUNT HAS A MAXIMUM CONTINUOUS OPERATING TEMPERATURE OF 120°F (49°C).  
[ -AT ] MOUNT HAS A MAXIMUM CONTINUOUS OPERATING TEMPERATURE OF 180°F (82°C).  
[ -AV ] MOUNT HAS A MAXIMUM CONTINUOUS OPERATING TEMPERATURE OF 200°F (93°C).
- SCALE: FULL

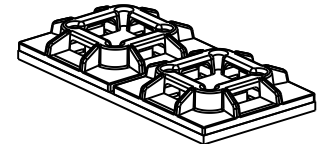

DIMENSIONS IN BRACKETS ARE METRIC [ mm ]

CAD FILENAME/LAYERS G03150FB\_PB\_SGABM20\_00B

**PANDUIT** CORP.

TINLEY PARK, ILLINOIS

ADHESIVE BACKED MOUNT - SUPER GRIP COMPATIBLE (SGABM20-A, -AT, -AV); (ABM20, 20B); (PAM075NY-A,)

UNLESS OTHERWISE SPECIFIED, DIMENSIONAL TOLERANCES ARE:  
(.X) ±0.05 (1.3) (.XXX) ±0.010 (0.25)  
(.XX) ±0.02 (0.5) ANGLES ±5°

UNLESS OTHERWISE SPECIFIED, ALL DIMENSIONS ARE GIVEN IN INCHES, THIRD ANGLE PROJECTION.

DRAWN BY JAD

MAT'L:

SCALE 2X

DATE 6/12/06

NYLON 6/6

DRAWING NO.

GB3150FB

DWG

A

SIZE

REV	DATE	BY	CHK	DESCRIPTION	ECN	R	CUST	SUP
OOB	11-6-09	TMSA		ADDED PART NUMBER SGABM20-AV	GB3150FB	OOB		