

**Order Number**  
**63904-6800**

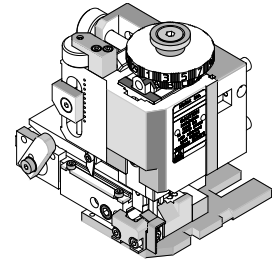

**Application Tooling Specification**

**FEATURES**

- Quick punch removal with the push of a button for fast and easy tooling change
- Applicator designed to industry-standard mounting and shut height 135.80mm (5.346")
- Quick setup time; plus, the crimp height, track and feed adjustments can be set without removing the applicator from the press
- Fine adjustment allows users to achieve target with little effort by adjusting in increments of 0.15mm (.0006") for conductor crimp height and .063mm (.0025") for insulation height
- Independent adjustment rings allow users to quickly adjust the conductor or insulation crimp height without affecting each other
- This tool is IPC/WHMA-A-620 Class 2 Compliant
- Directly adapts to most automatic wire processing machines

**SCOPE**

**Products:** 2.00mm (.079") Pitch Wire-to-Board Crimp Terminal, 24-30 AWG.

Terminal Series No.	Terminal Order No.		Wire Size		Insulation Diameter				Strip Length	
					IPC/WHMA-A-620♦		Terminal♦♦			
					AWG	mm <sup>2</sup>	mm	In.	mm	In.
50212	50212-8000	39-00-0424	24-30	—	0.90-1.10	.040-.043	0.80-1.40	.031-.055	1.30-1.80	.051-.071
50394	50394-8051	50394-8055	24-30	—	0.90-1.10	.040-.043	0.80-1.40	.031-.055	1.30-1.80	.051-.071
	50394-8052	50394-8099								
	50394-8054	50394-8999								
59354	59354-8081		24-28	—	0.90-1.10	.040-.043	0.80-1.40	.031-.055	1.30-1.80	.051-.071

♦To achieve optimum IPC/WHMA-A-620 insulation crimps, use this insulation OD range.

♦♦Overall insulation OD specification for terminal.

**DEFINITION OF TERMS**

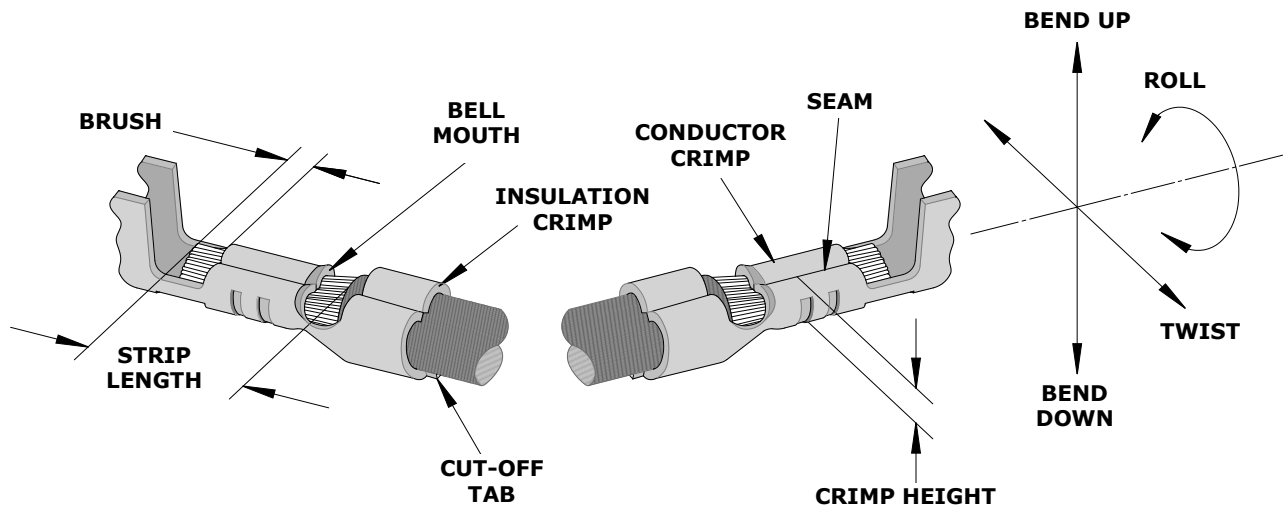

The above terminal drawing is a generic terminal representation. It is not an image of a terminal listed in the scope.

## CRIMP SPECIFICATION

Terminal Series No.	Bell Mouth		Cut-Off Tab Maximum		Conductor Brush	
	mm	In.	mm	In.	mm	In.
50212	0.05-0.35	.002-.014	0.20	.008	0.00-0.50	.000-.020
50394	0.05-0.35	.002-.014	0.20	.008	0.00-0.50	.000-.020
59354	0.05-0.35	.002-.014	0.20	.008	0.00-0.50	.000-.020

Terminal Series No.	Bend Up	Bend Down	Twist	Roll	Punch Width (Ref)				Seam
					Conductor		Insulation		
	Degree	Degree	mm	In.	mm	In.			
50212	4	3	3	4	1.00	.039	1.40	.055	Seam shall not be open and no wire allowed out of the crimping area
50394	4	3	3	4	1.00	.039	1.40	.055	
59354	4	3	3	4	1.00	.039	1.40	.055	

After crimping, the conductor profile should measure the following:

Terminal Series No.	Wire Size		Conductor Crimp Height		Pull Force Minimum	
	AWG	mm <sup>2</sup>	mm	In.	N	Lb.
50212	24	—	0.60-0.65	.024-.026	29.3	6.60
	26	—	0.59-0.64	.023-.025	19.6	4.40
	28	—	0.56-0.61	.022-.024	9.8	2.20
	30	—	0.53-0.58	.021-.023	4.9	1.10
50394	24	—	0.60-0.65	.024-.026	29.3	6.60
	26	—	0.59-0.64	.023-.025	19.6	4.40
	28	—	0.56-0.61	.022-.024	9.8	2.20
	30	—	0.53-0.58	.021-.023	4.9	1.10
59354	24	—	0.60-0.65	.024-.026	29.3	6.60
	26	—	0.59-0.64	.023-.025	19.6	4.40
	28	—	0.56-0.61	.022-.024	9.8	2.20

### Tool Qualification Notes

1. Pull force should be measured with no influence from the insulation crimp.
2. The above specifications are guidelines to an optimum crimp.

**PARTS LIST**

<b>FineAdjust Applicator 63904-6800</b>				
<b>Item</b>	<b>Order No.</b>	<b>Engineering No.</b>	<b>Description</b>	<b>Quantity</b>
<b>Perishable Tooling</b>				
	63904-6870	63904-6870	Tool Kit (All "Y" Items)	REF
1	63444-1003	63444-1003	Conductor Punch	1 Y
2	63445-1013	63445-1013	Conductor Anvil	1 Y
3	63446-1231	63446-1231	Insulation Punch	1 Y
4	63445-1204	63445-1204	Insulation Anvil	1 Y
5	63443-0003	63443-0003	Front Cut-Off Plunger	1 Y
6	63443-0012	63443-0012	Front Plunger Retainer	1 Y
<b>Other Components (REF 005250)</b>				
7	11-18-4083	60707-8	Feed Guide	1
8	11-24-1067	4996-4	Cut-Off Plunger Spring	1
9	63443-0009	63443-0009	Front Scrap Chute	1
10	63443-0024	63443-0024	Key	1
11	63443-0090	63443-0090	Wire Stop	1
12	63443-1703	63443-1703	17.30mm Height Spacer	1
13	63443-2217	63443-2217	17.00mm Coarse Spacer	1
14	63443-2308	63443-2308	3.40mm Fine Spacer	1
15	63443-2802	63443-2802	Plunger Striker	1
16	63443-2906	63443-2906	Wire Hold Down Plunger	1
17	63443-6111	63443-6111	Rear Cover	1
18	63600-0021	63600-0021	Spring	1
<b>Frame</b>				
19	63800-4901	63800-4901	Top	1
20	63801-3281	63801-3281	Base	1
21	63801-4650	63801-4650	Track	1
<b>Hardware</b>				
22	—	—	M3 by 6 Long SHCS	2*
23	—	—	M3 by 6 Long FHCS	1*
24	—	—	M4 by 6 Long SHCS	2*
25	—	—	M4 by 12 Long BHCS	2*
26	—	—	M4 by 50 Long SHCS	2*
27	—	—	M5 by 12 Long SHCS	1*
28	—	—	#10-32 by 3/8" Long Flat Point SSS	1*
29	—	—	#10-32 Hex Jam Nut	1*

\*Available from an industrial supply company.

**ASSEMBLY DRAWING**

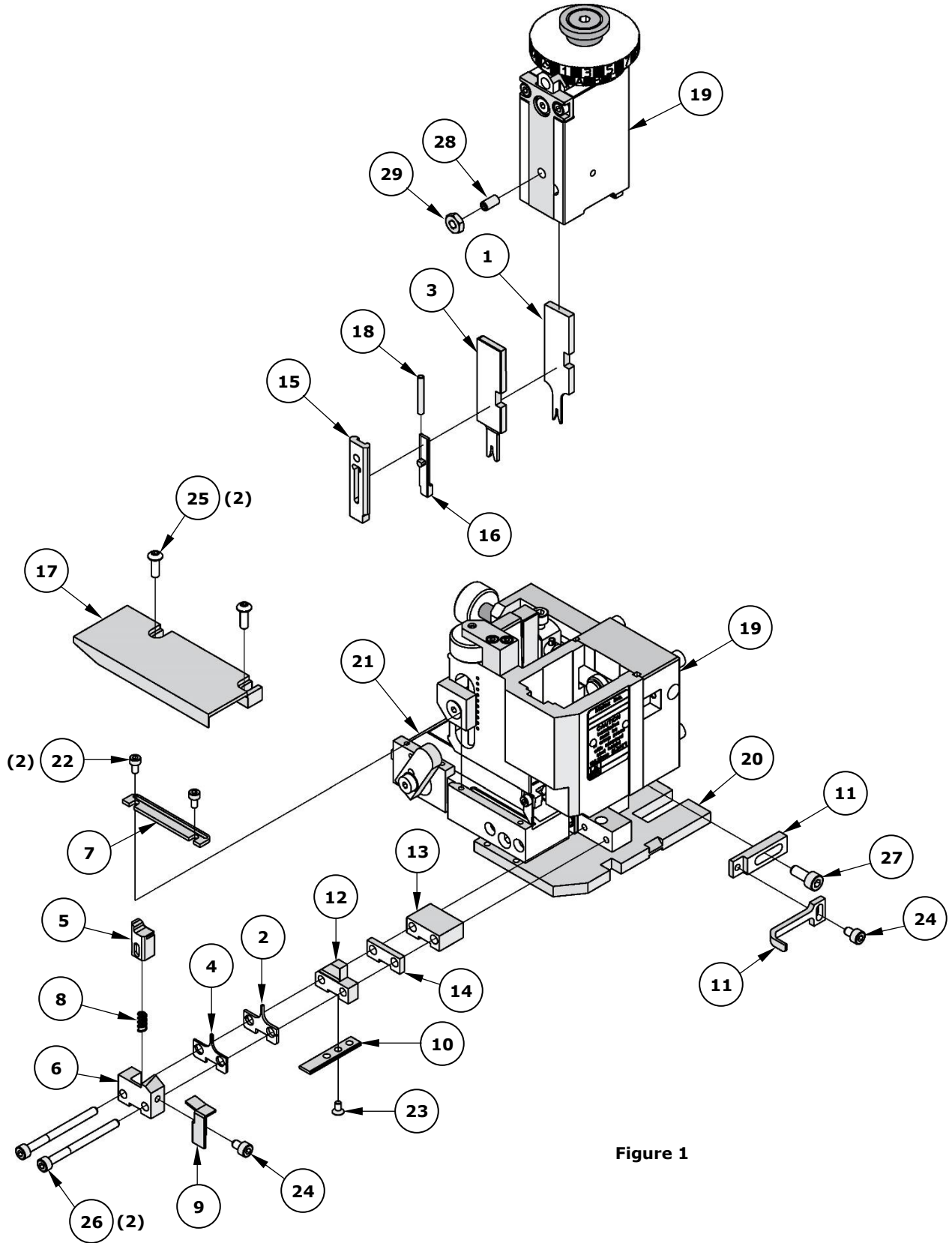

Figure 1

## NOTES

---

1. Molex recommends that an extra perishable tooling kit be maintained at your facility.
2. Verify tooling alignment by manually cycling the press and applicator before crimping under power. Check that all screws are tight.
3. Slugs, terminals, dirt and oil should be kept clear of the work area.
4. Wear safety glasses at all times.
5. For recommended maintenance, refer to the FineAdjust manual.

**CAUTION:** This applicator should only be used in a press with a shut height of 135.8mm (5.346"). Tooling damage could result at a lower setting.

**CAUTION:** To prevent injury, never operate this applicator without the guards supplied with the press or wire-processing machine in place. Reference the press or wire-processing manufacturer's instruction manual.

**CAUTION:** Molex crimp specifications are valid only when used with Molex terminals, applicators and tooling.

### Application Tooling Support

**Phone:** (402) 458-TOOL (8665)  
**E-Mail:** [applicationtooling@molex.com](mailto:applicationtooling@molex.com)  
**Website:** [www.molex.com/applicationtooling](http://www.molex.com/applicationtooling)

Molex is a registered trademark of Molex, LLC in the United States of America and may be registered in other countries; all other trademarks listed herein belong to their respective owners.