



ON Semiconductor®

FAN6500XX Sync Buck Converter

Comment Legend

- Required Hardware
- Optional Hardware
- Telemetry Hardware

ON Semiconductor		
Title FAN6500XX Sync Buck Converter	Orderable Part Number STR-FAN6500XX-GEVB	
Variant Name FAN65008B	Document Number ONSEC-19-005	Rev REV2
Date: Friday, December 18, 2020	Sheet 1 of 7	1

FAN6500XX Sync Buck

FAN6500XX Controller

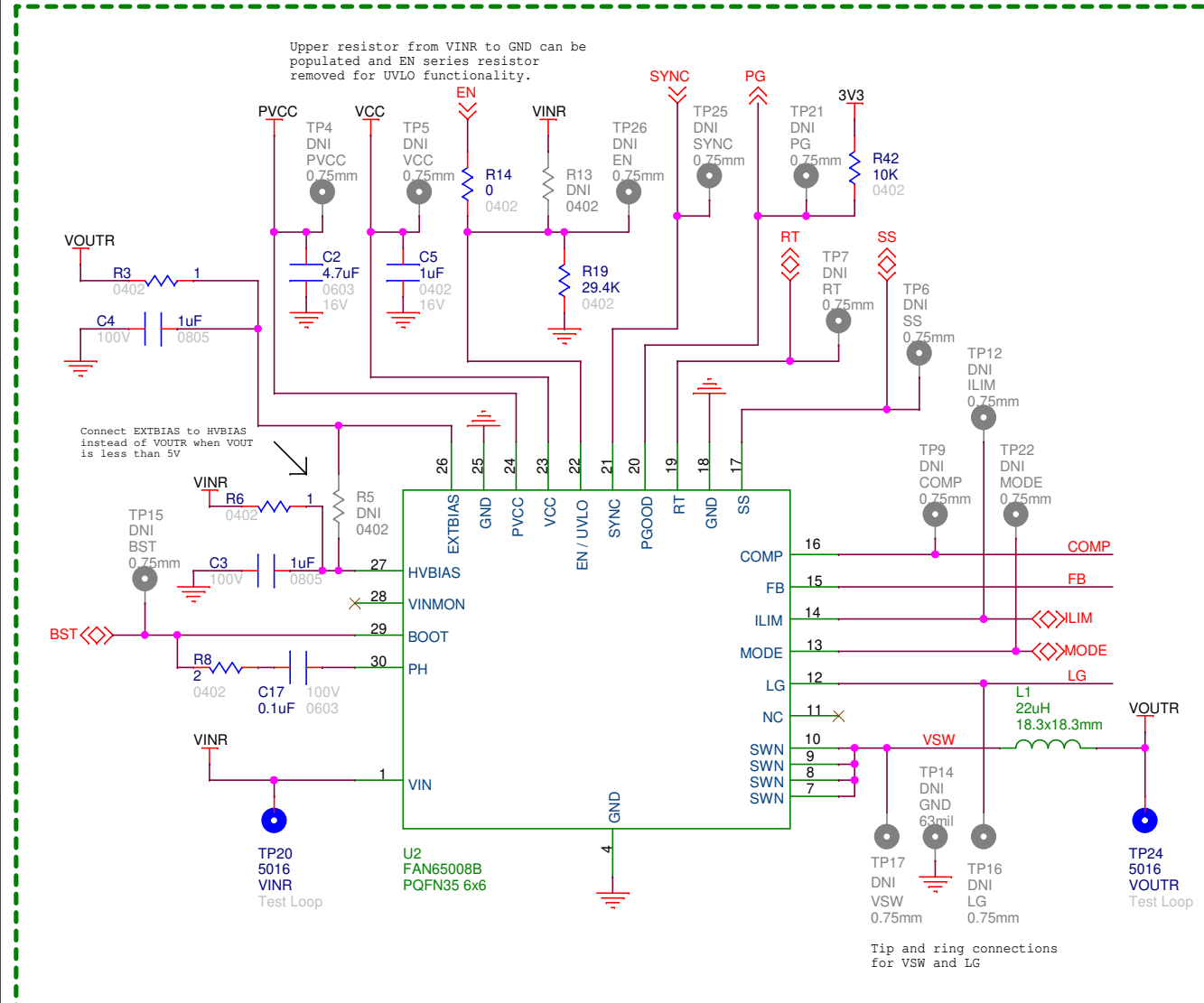

Input Filter

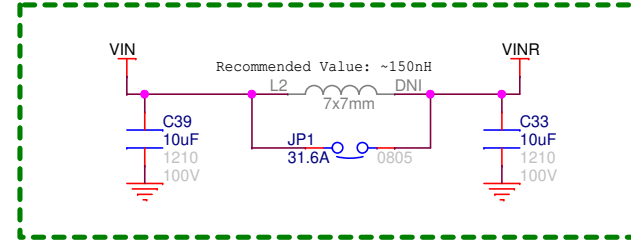

Input Capacitors

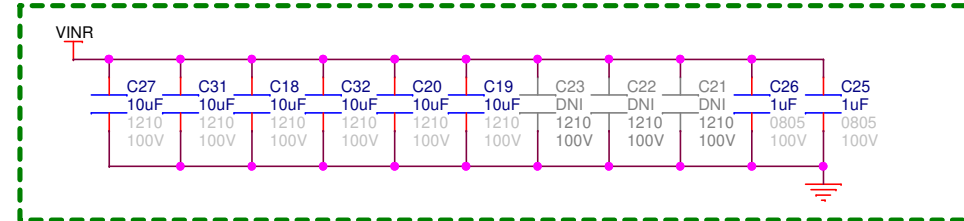

Output Capacitors

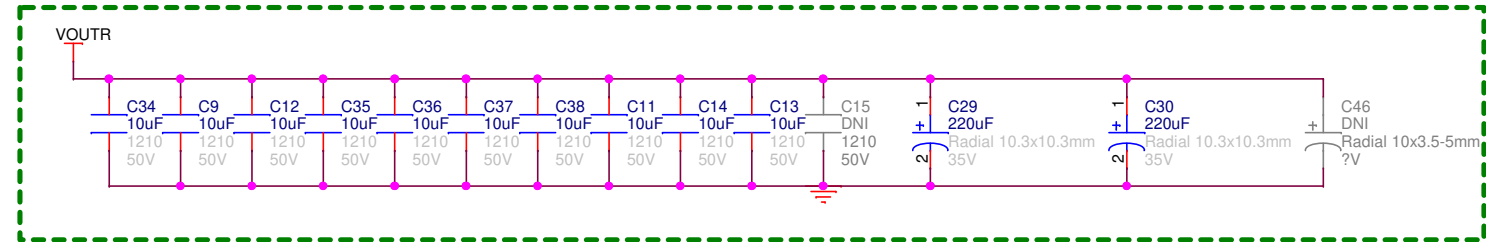

Headers and Test Points

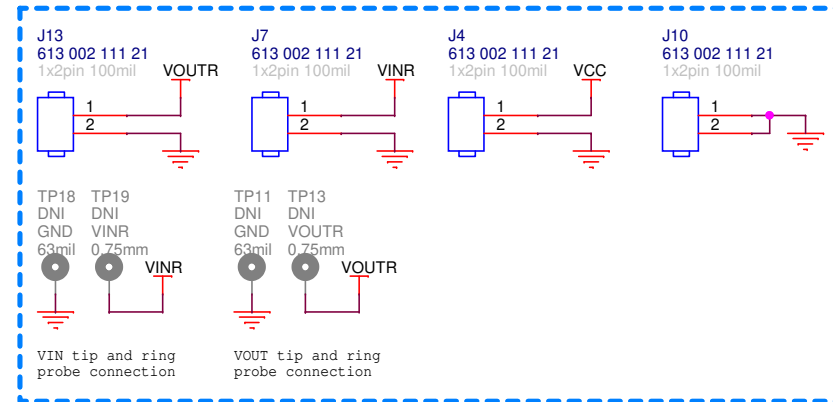

Bode Connection

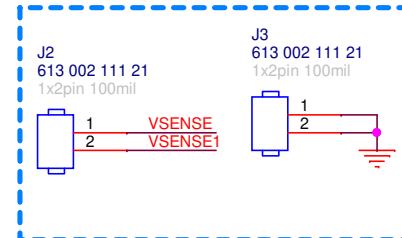

Tuning Connection

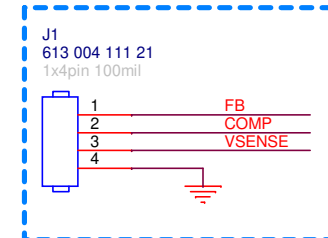

Snubber

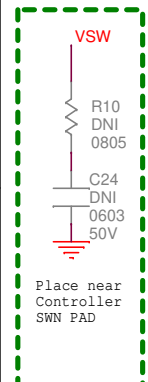

Compensation

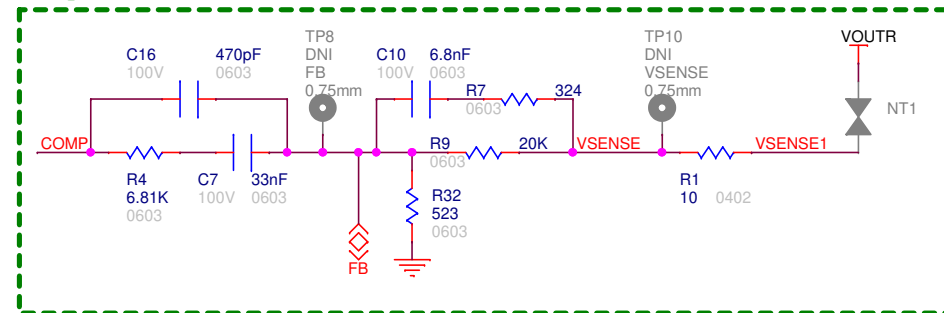

ON Semiconductor

Title FAN6500XX Sync Buck Converter		Orderable Part Number STR-FAN6500XX-GEVB	
Variant Name FAN65008B		Document Number ONSEC-19-005	Rev REV2
Date: Friday, December 18, 2020		Sheet	2 of 7

Strata Assisted/Telemetry

ADC Voltage Dividers

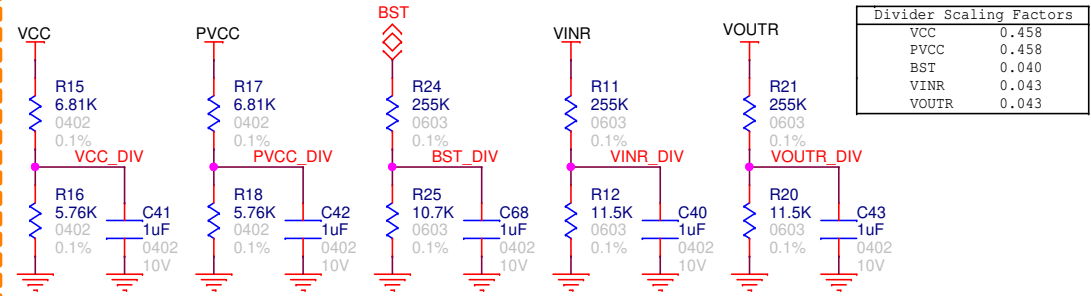

Telemetry

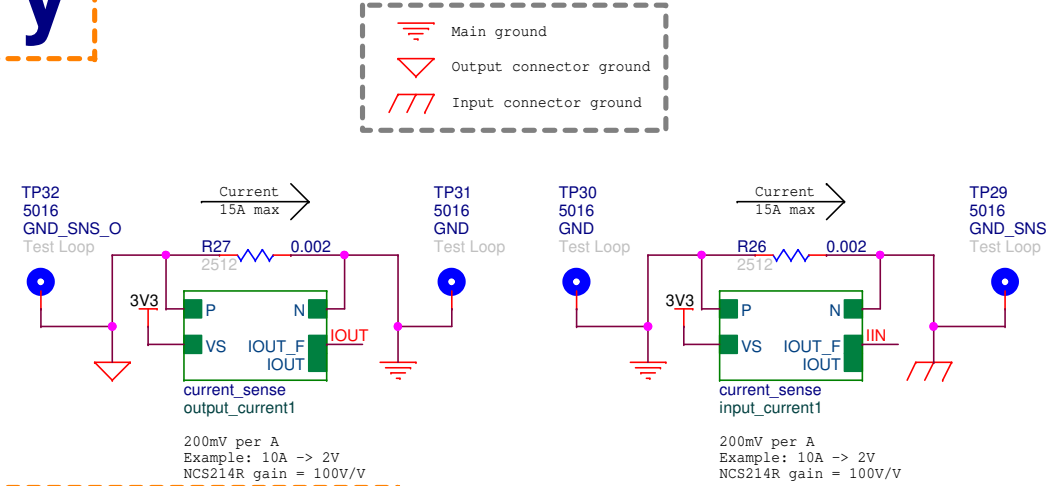

INPUT/OUTPUT Power Connectors

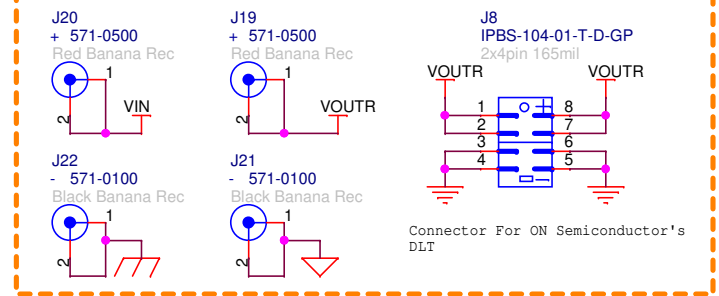

STRATA EMBEDDED

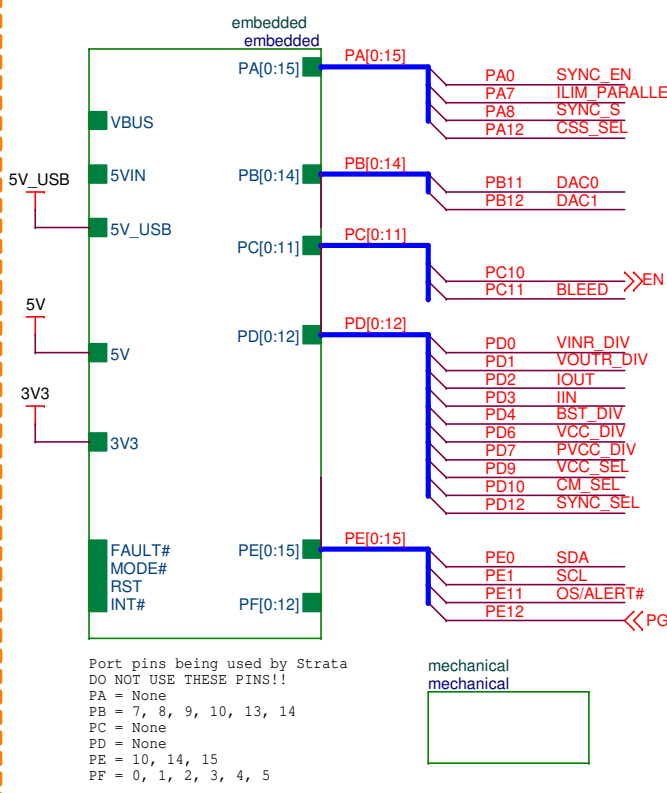

Level Shifters

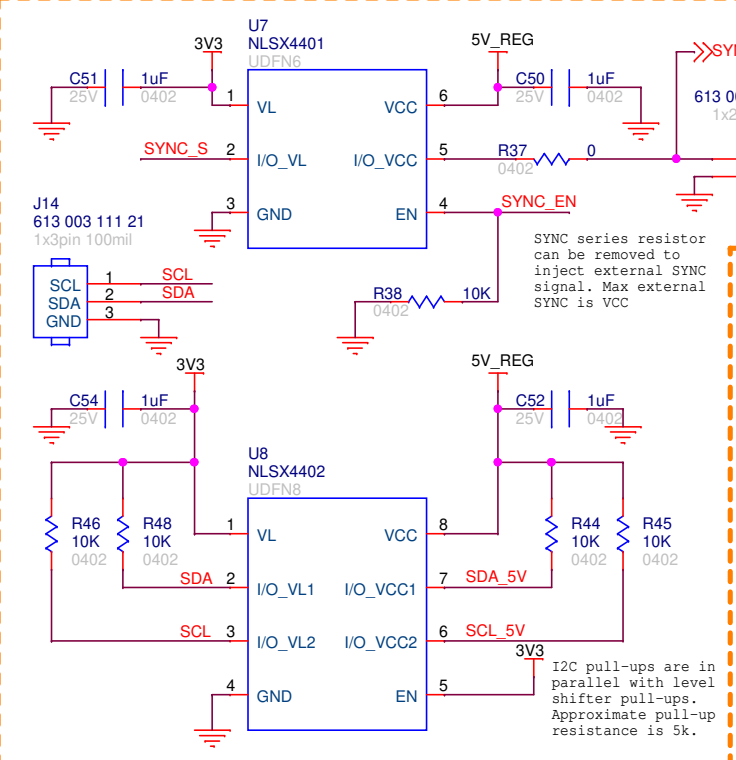

DAC Output Voltage Select

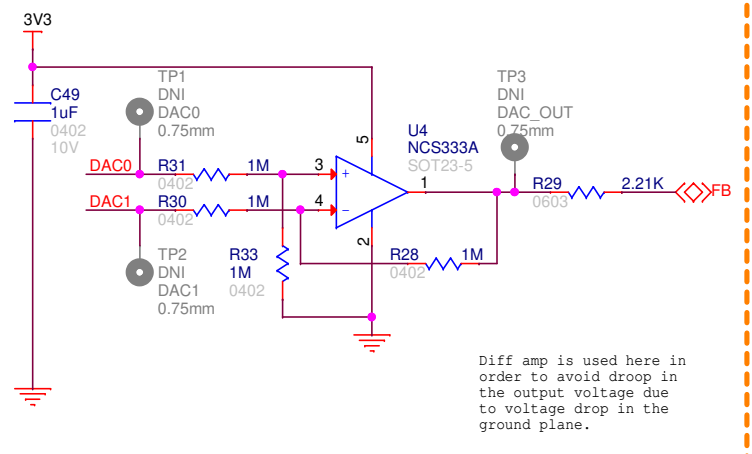

5V LDO/ Charge Pump

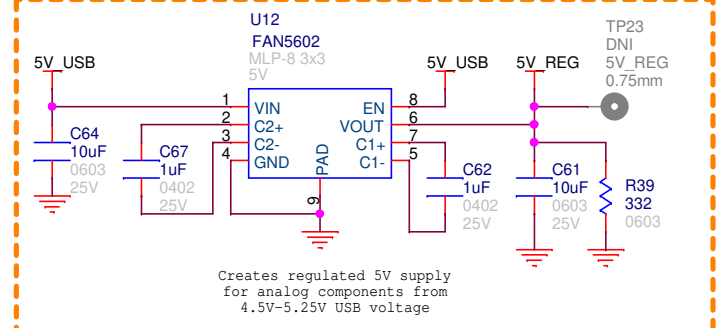

Switching Frequency Select

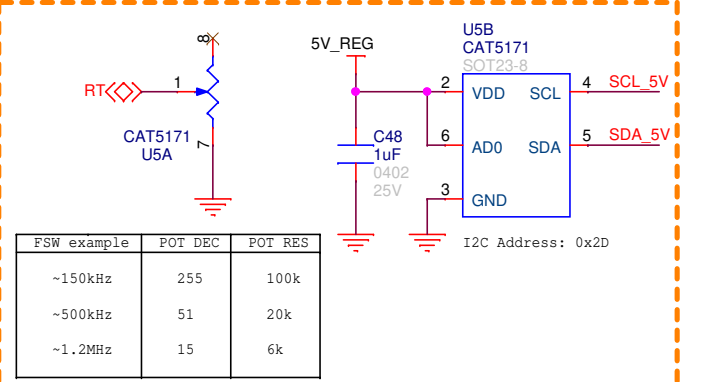

VCC Select Switch

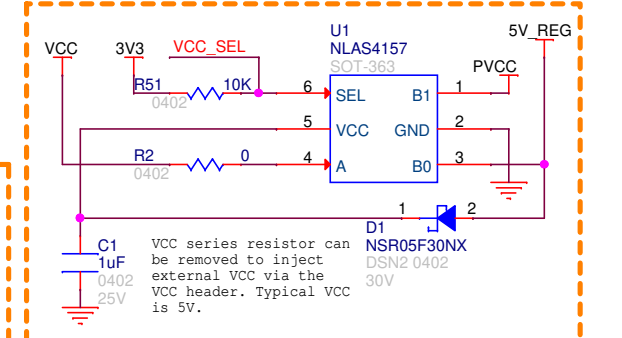

Strata OCP set

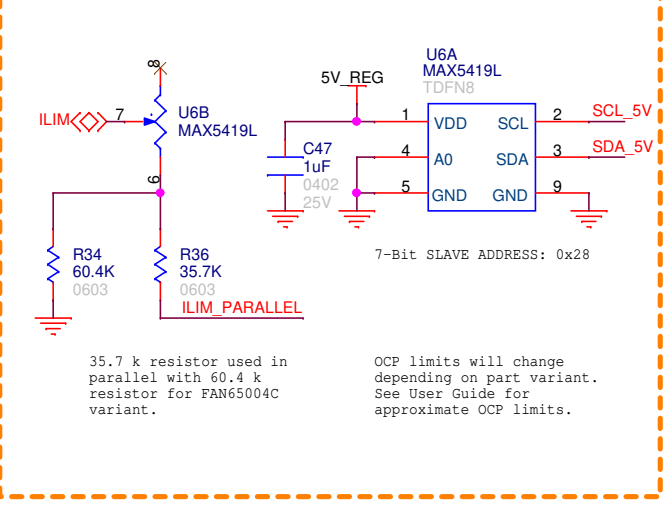

Strata MODE set

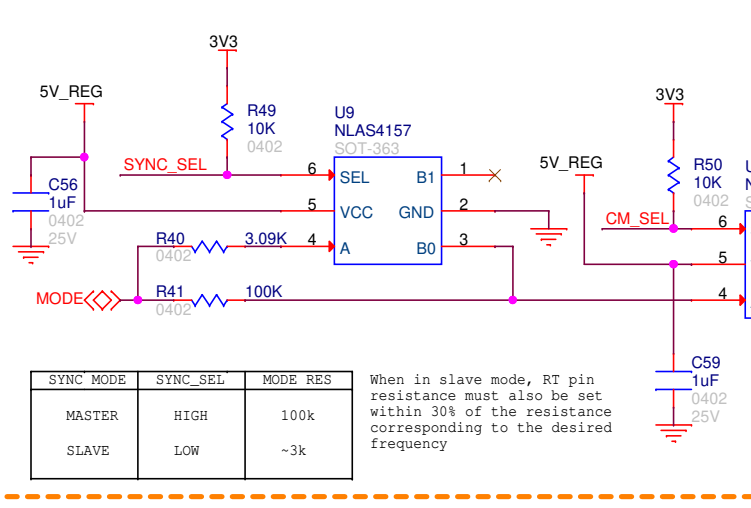

Soft-Start Select

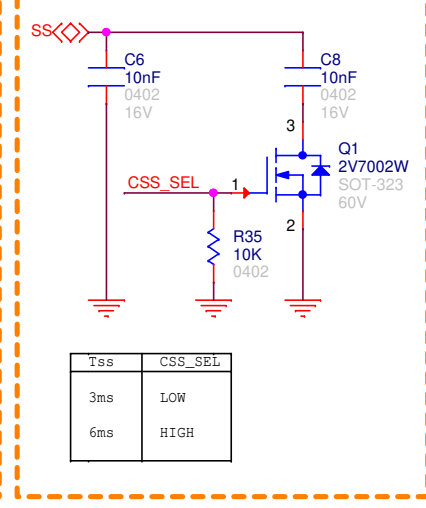

Bleeder

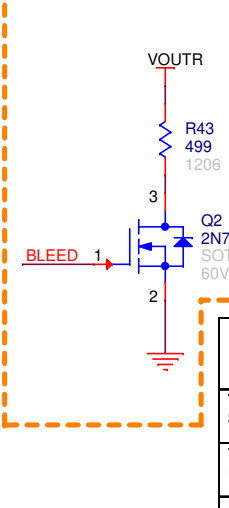

ON Semiconductor

Title Strata Assisted/Telemetry		Orderable Part Number STR-FAN6500XX-GEVB	
Variant Name FAN65008B		Document Number ONSEC-19-005	Rev REV2
Date: Friday, December 18, 2020		Sheet	3 of 7

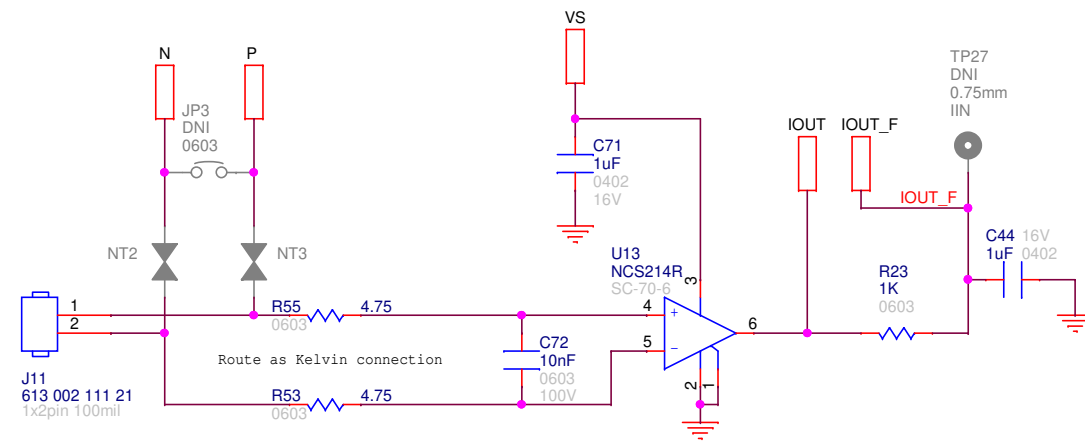

ON Semiconductor		
Title Input Current Sense		Orderable Part Number STR-FAN6500XX-GEVB
Variant Name FAN65008B	Document Number ONSEC-19-005	Rev REV2
Date: Friday, December 18, 2020	Sheet 4 of 7	1

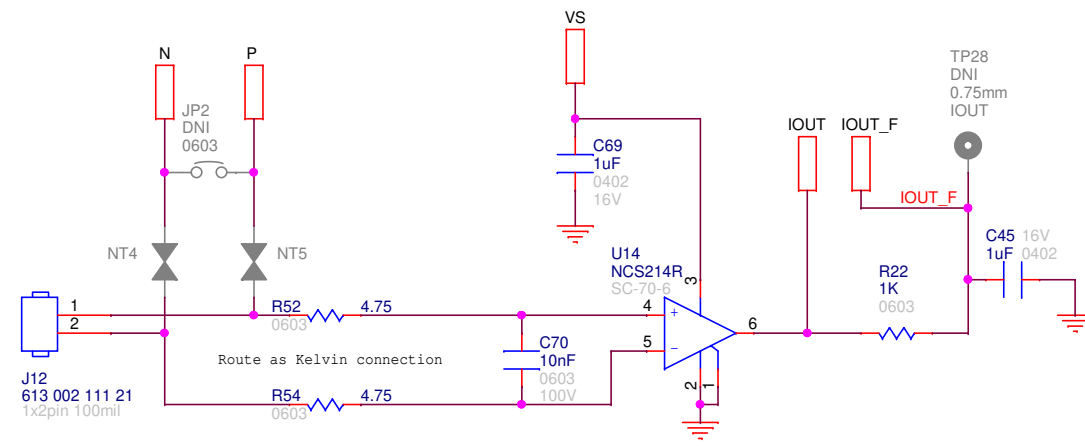

ON Semiconductor		
Title Output Current Sense		Orderable Part Number STR-FAN6500XX-GEVB
Variant Name FAN65008B		Document Number ONSEC-19-005
Date: Friday, December 18, 2020		Rev REV2
Sheet 5 of 7		

Mechanical

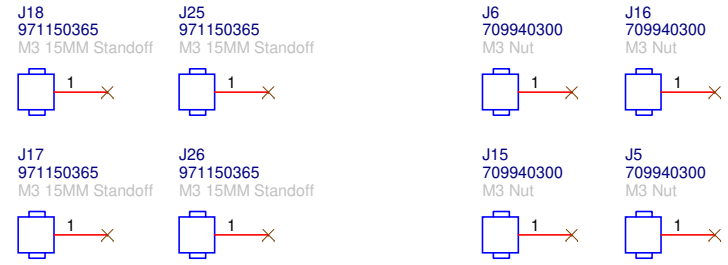

ON Semiconductor		
Title Mechanical	Orderable Part Number STR-FAN6500XX-GEVB	
Variant Name FAN65008B	Document Number ONSEC-19-005	Rev REV2
Date: Friday, December 18, 2020	Sheet 7 of 7	1