



MONITOR CONTROLLER

Table of Contents-

1.	GENERAL DESCRIPTION	2
2.	FEATURES	2
3.	PIN CONFIGURATIONS	3
4.	PIN DESCRIPTION.....	4
5.	BLOCK DIAGRAM	7
6.	FUNCTIONAL DESCRIPTION	8
6.1.	Address Space.....	8
6.2.	SFRs accessed using 'Direct Addressing'	8
6.3.	SFRs accessed using 'MOVX @Ri'	10
6.4.	Modified Timer 0 & Timer 1.....	16
6.5.	DDC1/SIO1 and SIO2 Ports	17
6.6.	Parabola Interrupt Generator	25
6.7.	Sync Processor.....	27
6.8.	Interrupts	30
6.9.	Reset Circuit- Power-low Detector & Watchdog Timer.....	32
7.	ELECTRICAL CHARACTERISTICS.....	33
7.1.	Absolute Maximum Ratings	33
7.2.	D.C. Characteristics	33
8.	APPENDIX A. APPLICATION NOTE FOR USAGE OF ADC.....	35
9.	PACKAGE DIMENSIONS	37
9.1.	32-pin P-DIP.....	37
9.2.	40-pin DIP	37
9.3.	44-pin PLCC.....	38
10.	REVISION HISTORY	39



1. GENERAL DESCRIPTION

The W78E378 is a stand-alone high-performance microcontroller specially designed for monitor control applications. The device integrates the embedded 80C31 microcontroller core, on-chip Flash EPROM, 576 bytes of RAM, and a number of dedicated hardware monitor functions. Additional special function registers are incorporated to control the on-chip peripheral hardware. The chip is used to control the interface signal of other devices in the monitor and to process the video sync signals. Because of the highly integration and Flash cell for program memory, the device can offer users the competitive advantages of low cost and reduced development time.

2. FEATURES

- 80C31 MCU Core Embedded
- 32K Bytes Flash EPROM(W78E378)
- Total 576 Bytes of On-chip Data RAM
 - 256 bytes accessed as in the 80C32
 - 320 bytes accessed as external data memory via "MOVX @Ri"
- PWM DACs
 - Eight 8-bit Static PWM DACs: DAC0–DAC8
 - Three 8-bit Dynamic PWM DACs: DAC9–DAC10
- Sync Processor
 - Horizontal & Vertical Polarity Detector
 - Sync Separator for Composite Sync
 - 12-bit Horizontal & Vertical Frequency Counter
 - Programmable Dummy Frequency Generator
 - Programmable H-clamp Pulse Output
 - SOA Interrupt
 - Hsync/2 Output
- Serial Ports:
 - DDC1 Port- support DDC1
 - SIO1 & SIO2 Ports - each can support DDC2B/ 2B+/ 2Bi/ 2AB (each has 2 slave addresses)
- Two 16-bit Timer/Counters (8031's Timer0 & Timer1)
- One External Interrupt Input (8031's $\overline{\text{INT0}}$)
- One Parabola Interrupt Generator
- One ADC with 7 Multiplexed Analog Inputs
- Two 12 mA(min) Output Pins for Driving LEDs
- Watchdog Timer ($2^{22}/F_{\text{osc}} = 0.42\text{s}$ @ $F_{\text{osc}} = 10\text{ MHz}$)
- Power Low Reset
- Frequency: 10 MHz max. (with the same performance as a normal 8051 that uses 20 MHz)
- Packaged in 40/32-pin 600 mil DIP & 44-pin PLCC



3. PIN CONFIGURATIONS

40-pin DIP:	W78E378E	40-pin DIP		
3.1.1.	P4.1	1	40	P4.2
	P4.0 (HFI)	2	39	P4.3
	P3.5 (ADC4, T0)*	3	38	P3.6 (ADC5, T1)*
	P1.1 (DAC1)*	4	37	P1.2 (DAC2)*
32-pin DIP:	W78E378	5	36	P1.3 (DAC3)*
	P1.0 (DAC0)*	6	35	P1.4 (DAC4)*
	P3.4 (VOUT)	7	34	P1.5 (DAC5)*
	P3.3 (HOUT)	8	33	P1.6 (DAC6)*
	H _{IN}	9	32	P1.7 (DAC7)*
	V _{IN}	10	31	P2.0 (DAC8)
	RESET	11	30	P2.1 (DAC9)
	V _{DD}	12	29	P2.2 (DAC10)
	V _{SSA}	13	28	P2.3 (Hclamp)
	OSCOUT	14	27	P2.4 (ADC0)
	OSCIN	15	26	P2.5 (ADC1)
	P3.2 (INT0)	16	25	P2.6 (ADC2)
	P3.1 (SCL)*	17	24	P2.7 (ADC3)
	P3.0 (SDA)*	18	23	P3.7 (ADC6)*
	V _{SS}	19	22	P4.4 (SCL2)*
	P4.7 (HFO)	20	21	P4.5 (SDA2)*

44-pin PLCC

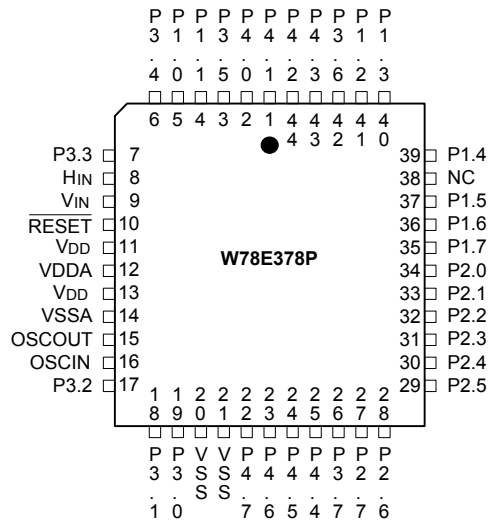

4. PIN DESCRIPTION

PIN NAME	I/O	DESCRIPTION
$\overline{\text{RESET}}$	I/O	Chip reset input (active low) input & Internal reset output (generated by WDT or power low) TTL Schmitt trigger input, internal pull-up ~30 KΩ $I_{OL} = +12 \text{ mA} @ V_{OL} = 0.45\text{V}$
VDD	-	Positive power supply
VSS	-	Ground
VSS	-	Ground
OSCO _{UT}	O	Output from the inverting oscillator amplifier
OSCI _N	I	Input to the inverting oscillator amplifier, 10 MHz max.
HIN	I	Hsync input TTL Schmitt trigger input , w/o PMOS $V_{IH}/V_{IL} = 2.0\text{V}/0.8\text{V}$, $V_{+}/V_{-} = \sim 1.6\text{V}/1.1\text{V}$
VIN	I	Vsync input TTL Schmitt trigger input, w/o PMOS $V_{IH}/V_{IL} = 2.0\text{V}/0.8\text{V}$, $V_{+}/V_{-} = \sim 1.6\text{V}/1.1\text{V}$
P1.0 (DAC0)	I/O	General purpose I/O, DAC0 special function output Open-drain output , sink current: 15 mA
P1.1 (DAC1)	I/O	General purpose I/O, DAC1 special function output Open-drain output , sink current: 15 mA
P1.2 (DAC2)	I/O	General purpose I/O, DAC2 special function output Open-drain output , sink current: 4 mA
P1.3 (DAC3)	I/O	General purpose I/O, DAC3 special function output Open-drain output , sink current: 4 mA
P1.4 (DAC4)	I/O	General purpose I/O, DAC4 special function output Open-drain output , sink current: 4 mA
P1.5 (DAC5)	I/O	General purpose I/O, DAC5 special function output Open-drain output , sink current: 4 mA
P1.6 (DAC6)	I/O	General purpose I/O, DAC6 special function output Open-drain output , sink current: 4 mA
P1.7 (DAC7)	I/O	General purpose I/O, DAC7 special function output Open-drain output , sink current: 4 mA



Pin Description, Continued

PIN NAME	I/O	DESCRIPTION
P2.0 (DAC8)	I/O	General purpose I/O, DAC8 Special Function output Sink/Source current: 4 mA/-100 μ A (-4 mA for SF output)
P2.1 (DAC9)	I/O	General purpose I/O, DAC9 Special Function output Sink/Source current: 4 mA/-100 μ A (-4 mA for SF output)
P2.2 (DAC10)	I/O	General purpose I/O, DAC10 Special Function output Sink/Source current: 4 mA/-100 μ A (-4 mA for SF output)
P2.3 (Hclamp)	I/O	General purpose I/O, Hclamp Special Function output Sink/Source current: 4 mA/-100 μ A (-4 mA for SF output)
P2.4 (ADC0)	I/O	General purpose I/O, ADC input channel 0 Sink/Source current: 4 mA/-100 μ A
P2.5 (ADC1)	I/O	General purpose I/O, ADC input channel 1 Sink/Source current: 4 mA/-100 μ A
P2.6 (ADC2)	I/O	General purpose I/O, ADC input channel 2 Sink/Source current: 4 mA/-100 μ A
P2.7 (ADC3)	I/O	General purpose I/O, ADC input channel 3 Sink/Source current: 4 mA/-100 μ A
P3.0 (SDA)	I/O	General purpose I/O, DDC port serial data I/O Schmitt trigger input $V_{IH}/V_{IL} = 0.7 V_{DD}/0.3 V_{DD}$, $V_{+}/V_{-} = \sim 0.6 V_{DD}/0.4 V_{DD}$ Open-drain output , sink current: 8 mA
P3.1 (SCL)	I/O	General purpose I/O, DDC port serial clock I/O Schmitt trigger input $V_{IH}/V_{IL} = 0.7 V_{DD}/0.3 V_{DD}$, $V_{+}/V_{-} = \sim 0.6 V_{DD}/0.4 V_{DD}$ Open-drain output , sink current: 8 mA
P3.2 ($\overline{\text{INT0}}$)	I/O	General purpose I/O, $\overline{\text{INT0}}$ input Sink/Source current: 1 mA/ -100 μ A
P3.3 (HOUT)	I/O	General purpose I/O, HOUT special function output Sink/Source current: 4 mA/-100 μ A (-4 mA for SF output)
P3.4 (VOUT)	I/O	General purpose I/O, VOUT special function output Sink/Source current: 4 mA/-100 μ A (-4 mA for SF output)



Pin Description, Continued

PIN NAME	I/O	DESCRIPTION
P3.5 (ADC4, T0)	I/O	General purpose I/O, ADC input channel 4 Open-drain output , sink current: 4 mA
P3.6 (ADC5, T1)	I/O	General purpose I/O, ADC input channel 5 Open-drain output , sink current: 4 mA
P3.7 (ADC6)	I/O	General purpose I/O, ADC input channel 6 Open-drain output , sink current: 4 mA
P4.0 (HFI)	I/O	P4.0 Output, HFI Input Sink/Source current: 4 mA/-4 mA
P4.1	O	P4.1 Output Sink/Source current: 4 mA/-4 mA
P4.2	O	P4.2 Output Sink/Source current: 4 mA/-4 mA
P4.3	O	P4.3 Output Sink/Source current: 4 mA/-4 mA
P4.4 (SCL2)	I/O	P4.4 Output, SIO2 port serial clock I/O Schmitt trigger input $V_{IH}/V_{IL} = 0.7 V_{DD}/0.3 V_{DD}$, $V_{+}/V_{-} = \sim 0.6 V_{DD}/0.4 V_{DD}$ Open-drain output , sink current: 8 mA
P4.5 (SDA2)	I/O	P4.5 Output, SIO2 port serial data I/O Schmitt trigger input $V_{IH}/V_{IL} = 0.7 V_{DD}/0.3 V_{DD}$, $V_{+}/V_{-} = \sim 0.6 V_{DD}/0.4 V_{DD}$ Open-drain output , sink current: 8 mA
P4.6	O	P4.6 Output Sink/Source current: 4 mA/-4 mA
P4.7 (HFO)	O	P4.7 Output, HFO Output Sink/Source current: 4 mA/-4 mA

5. BLOCK DIAGRAM

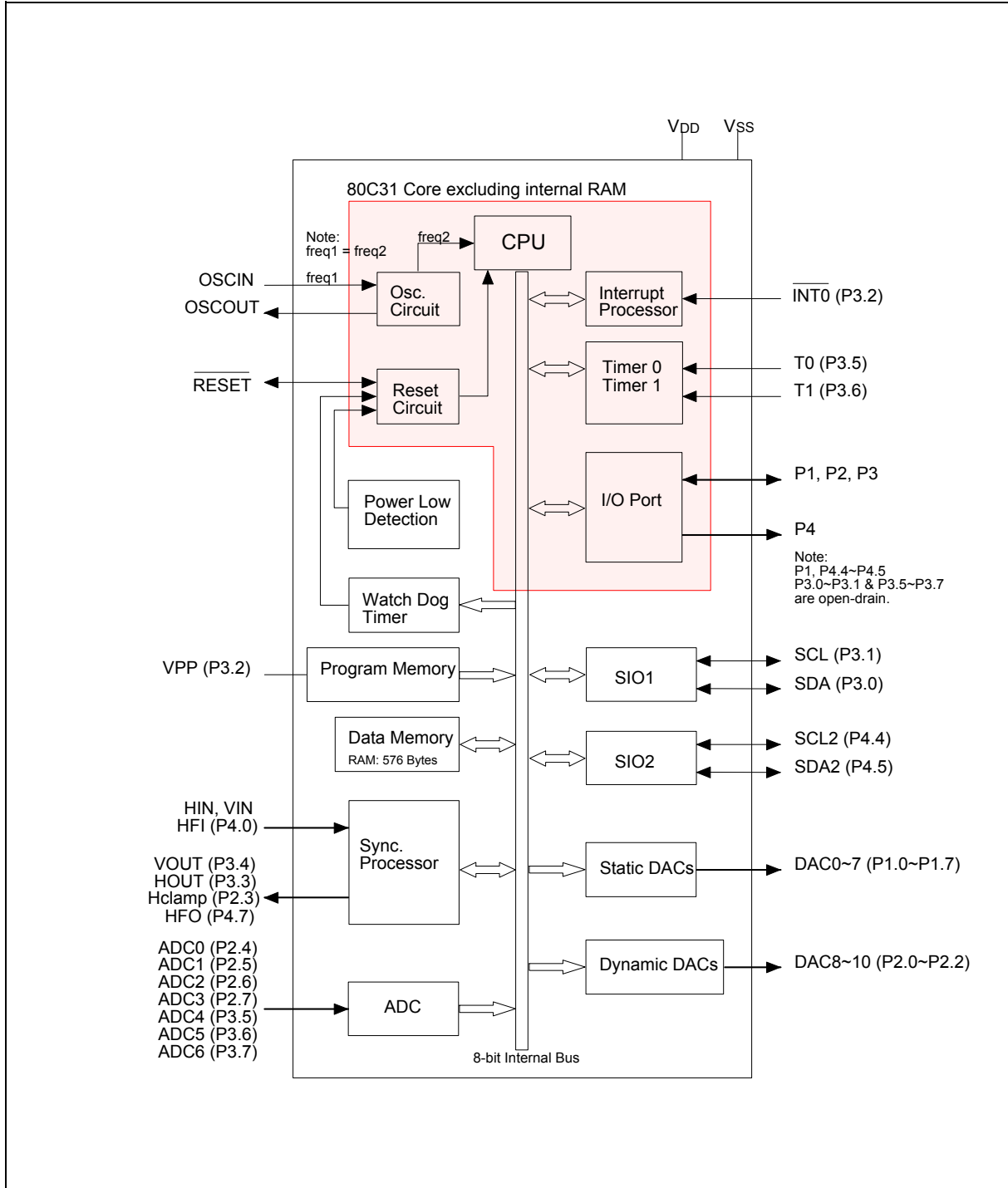



6. FUNCTIONAL DESCRIPTION

6.1. Address Space

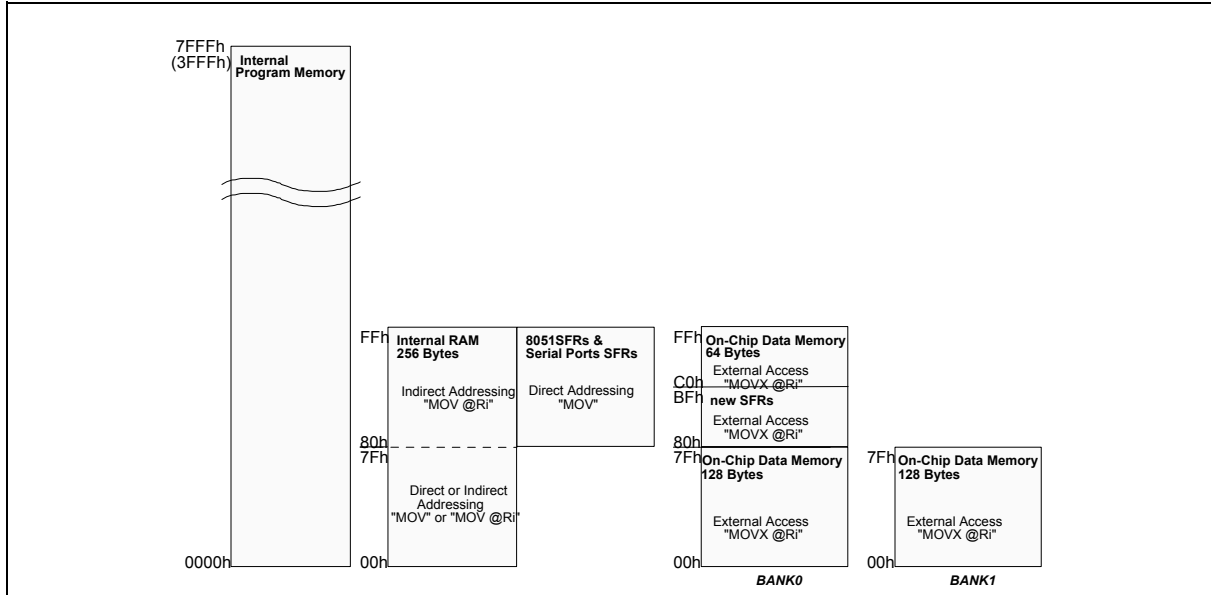

Program/Data/SFRs Address Space

6.2. SFRs accessed using 'Direct Addressing'

	REGISTER	ADDRESS	BITS	POWER ON RESET	RESET	R/W
1	A*	E0h	8	00h	00h	R/W
2	B*	F0h	8	00h	00h	R/W
3	PSW*	D0h	8	00h	00h	R/W
4	SP	81h	8	00h	00h	R/W
5	DPL	82h	8	00h	00h	R/W
6	DPH	83h	8	00h	00h	R/W
7	IE*	A8h	8	00h	00h	R/W
8	IP*	B8h	8	00h	00h	R/W
9	TCON*	88h	8	00h	00h	R/W
10	TMOD	89h	8	00h	00h	R/W
11	TL0	8Ah	8	00h	00h	R/W
12	TH0	8Ch	8	00h	00h	R/W
13	TL1	8Bh	8	00h	00h	R/W
14	TH1	8Dh	8	00h	00h	R/W
15	PCON	87h	8	00h	x0h	R/W



SFRs accessed using 'Direct Addressing', continued

	REGISTER	ADDRESS	BITS	POWER ON RESET	RESET	R/W
16	P1*	90h	8	00h	00h	R/W
17	P2*	A0h	8	FFh	FFh	R/W
18	P3*	B0h	8	1Fh	1Fh	R/W
19	TMREG*	C0h	3	00h	xxh	R/W
20	S1CON*	D8h	8	00h	00h	R/W
21	S1STA	D9h	8	F8h	F8h	R
22	S1DAT	DAh	8	FFh	FFh	R/W
23	S1ADR1	DBh	8	00h	00h	R/W
24	S1ADR2	DCh	8	00h	00h	R/W
25	S2CON*	E8h	8	00h	00h	R/W
26	S2STA	E9h	8	F8h	F8h	R
27	S2DAT	EAh	8	FFh	FFh	R/W
28	S2ADR1	EBh	8	00h	00h	R/W
28	S2ADR2	ECh	8	00h	00h	R/W

Notes:

1. The SFRs marked with an asterisk (*) are both bit- and byte-addressable.
2. Port 1 and P3.5–P3.7 outputs low during & after reset.
3. "x" means no reset action.
4. The SFRs in the shaded region are new-defined.

*** Modified PCON**

BIT	NAME	FUNCTION
0	ADCS2	ADC channel Select bit 2
1	PD	Power Down bit
2	GF0	General purpose flag bit
3	GF1	General purpose flag bit
4	TEST0	Test purpose flag bit
5	TEST1	Test purpose flag bit
6	ADCcal	Set 0/1 to select 1.0V/3.0V for ADC calibration
7	CPUhalt	Set to let CPU halt when the chip runs internally

*** TMREG: Test Mode Register**

BIT	NAME	FUNCTION
0	TM1	Test Mode1
1	TM2	Test Mode2
2	TM3	Test Mode3



6.3. SFRs accessed using 'MOVX @Ri'

	REGISTER	ADDRESS	BITS	POWER ON RESET	RESET	R/W TYPE
1	CTRL1	80h	8	00h	00h	W
2	CTRL2	81h	8	00h	00h	W
3	P1SF	82h	8	00h	xxh	W
4	P2SF	83h	8	00h	xxh	W
5	P3SF	84h	8	00h	00h	W
6	PARAL	85h	8	00h	00h	R/W
7	PARAH	86h	5	00h	00h	R/W
8	HFCOUNTL	87h	8	x	x	R
9	HFCOUNTH	88h	8	x	x	R
10	VFCOUNTL	89h	8	x	x	R
11	VFCOUNTH	8Ah	8	x	x	R
12	WDTCLR	8Bh	-	x	x	W
13	SOARL	8Ch	8/6	x	x	R/W
14	SOARH	8Dh	8/6	x	x	R/W
15	SOACLR	8Eh	-	x	x	W
16	INTMSK	8Fh	6	00h	00h	R/W
17	INTVECT	90h	6	00h	00h	R
18	INTCLR	91h	6	x	x	W
19	DDC1	92h	8	x	x	W
20	ADC	93h	8	x	x	R
21	DAC0	94h	8	00h	x	R/W
22	DAC1	95h	8	00h	x	R/W
23	DAC2	96h	8	00h	x	R/W
24	DAC3	97h	8	00h	x	R/W
25	DAC4	98h	8	00h	x	R/W
26	DAC5	99h	8	00h	x	R/W
27	DAC6	9Ah	8	00h	x	R/W
28	DAC7	9Bh	8	00h	x	R/W
29	DAC8	9Ch	8	00h	x	R/W
30	DAC9	9Dh	8	00h	x	R/W
31	DAC10	9Eh	8	00h	x	R/W
32	P4	9Fh	8	FFh	FFh	W
33	CTRL3	A0h	0	00h	00h	W

Note: "x" means no reset action.



* **CTRL1:** Control Register 1 (Write Only)

BIT	NAME	FUNCTION
0	ADCSTRT	A-to-D Conversion START control Set by S/W to start conversion. Cleared by H/W while conversion completed (read SOARH.6 to check).
1	ADCS0	ADC channel Select bit 0
2	ADCS1	ADC channel Select bit 1
3	ENDDC1	Enable DDC1
4	HCES	H-Clamp Edge Select 0: Select leading edge of restored Hsync 1: Select trailing edge of restored Hsync
5	HCWS	H-Clamp Width Select bit
6	DUMMYEN	Dummy signal Enable
7	VSDIS	Vsync Separator Disable, 0: Enable, 1: Disable

* **CTRL2:** Control Register 2 (Write Only)

BIT	NAME	FUNCTION
0	HSPS	HSync Polarity Select 0: Positive, 1: Negative
1	VSPS	VSsync Polarity Select 0: Positive, 1: Negative
2	HDUMS0	H Dummy frequency Select 0
3	VDUMS	V Dummy frequency Select
4	DDC1B9	Bit 9 in DDC1 mode
5	WDTEN	Enable Watch Dog Timer
6	SOAHDIS	Disable SOA low to high detection
7	OSCHI	OSC freq. Higher than 10 MHz

* **CTRL3:** Control Register 3 (Write Only)

BIT	NAME	FUNCTION
0	ENHFO	Enable HF input/output for P4.0/P4.7, respectively 0: Disable, 1: Enable
1	HDUMS1	H Dummy frequency Select 1
2	HFO_POL	Select HFO polarity 0: Positive, 1: Negative
3	HFO_HALF	Select HFO output freq. 0: the same as HFI, 1: half of the HFI
4	ENBNK1	Select on-chip ext. RAM bank 0: Bank 0, 1: Bank 1
5-7	-	-



***P1SF:** Port1 special function output enable register (Write Only)

BIT	NAME	FUNCTION
0	P10SF	Port 1.0 Special Function enable (DAC0 output)
1	P11SF	Port 1.1 Special Function enable (DAC1 output)
2	P12SF	Port 1.2 Special Function enable (DAC2 output)
3	P13SF	Port 1.3 Special Function enable (DAC3 output)
4	P14SF	Port 1.4 Special Function enable (DAC4 output)
5	P15SF	Port 1.5 Special Function enable (DAC5 output)
6	P16SF	Port 1.6 Special Function enable (DAC6 output)
7	P17SF	Port 1.7 Special Function enable (DAC7 output)

***P2SF:** Port2 special function output enable register (Write Only)

BIT	NAME	FUNCTION
0	P20SF	Port 2.0 Special Function enable (DAC8 output)
1	P21SF	Port 2.1 Special Function enable (DAC9 output)
2	P22SF	Port 2.2 Special Function enable (DAC10 output)
3	P23SF	Port 2.3 Special Function enable (Hclamp output)
4	P24SF	Port 2.4 Special Function enable (ADC0 input)
5	P25SF	Port 2.5 Special Function enable (ADC1 input)
6	P26SF	Port 2.6 Special Function enable (ADC2 input)
7	P27SF	Port 2.7 Special Function enable (ADC3 input)

***P3SF:** Port3 special function output enable register (Write Only)

BIT	NAME	FUNCTION
0-2	-	-
3	P33SF	Port 3.3 Special Function enable (HOUT)
4	P34SF	Port 3.4 Special Function enable (VOUT)
5-7	-	-

***HFCOUNTL:** Horizontal frequency counter register, low byte (Read Only)

BIT	NAME	FUNCTION
0	HF0	H frequency count bit 0
1	HF1	H frequency count bit 1
2	HF2	H frequency count bit 2
3	HF3	H frequency count bit 3
4	HF4	H frequency count bit 4
5	HF5	H frequency count bit 5
6	HF6	H frequency count bit 6
7	HF7	H frequency count bit 7



***HFCOUNTH**: Horizontal frequency counter register, high byte (Read Only)

BIT	NAME	FUNCTION
0	HF8	H frequency count bit 8
1	HF9	H frequency count bit 9
2	HF10	H frequency count bit 10
3	HF11	H frequency count bit 11
4-5	-	-
6	NOH	Set by hardware if no Hin signal
7	HPOL	Hin polarity. 0: Positive, 1: Negative

***VFCOUNTL**: Vertical frequency counter register, low byte (Read Only)

BIT	NAME	FUNCTION
0	VF0	V frequency count bit 0
1	VF1	V frequency count bit 1
2	VF2	V frequency count bit 2
3	VF3	V frequency count bit 3
4	VF4	V frequency count bit 4
5	VF5	V frequency count bit 5
6	VF6	V frequency count bit 6
7	VF7	V frequency count bit 7

***VFCOUNTH**: Vertical frequency counter register, high byte (Read Only)

BIT	NAME	FUNCTION
0	VF8	V frequency count bit 8
1	VF9	V frequency count bit 9
2	VF10	V frequency count bit 10
3	VF11	V frequency count bit 11
4-5	-	-
6	NOV	Set by hardware if no VIN signal
7	VPOL	VIN polarity. 0: Positive, 1: Negative

* **INTVECT**: Interrupt Vector Register (Read Only)

BIT	NAME	FUNCTION
0	SCLINT	SCL pin pulled low detected
1	ADCINT	ADC conversion completed
2	DDC1INT	DDC1 port buffer empty
3	SOAINT	SOA condition happen
4	VEVENT	Vsync pulse detected or NOV = 1 (V counter overflow) (The VEVENT is designed to be generated only 'one' time if no Vsync input.)
5	PARAINT	Parabola Interrupt generated



* **INTMSK**: Interrupt Mask Register (Read/Write)

BIT	NAME	FUNCTION
0	MSCLINT	Set/clear to enable/disable SCLINT
1	MADCINT	Set/clear to enable/disable ADCINT
2	MDDC1INT	Set/clear to enable/disable DDC1INT
3	MSOAIN	Set/clear to enable/disable SOAIN
4	MVEVENT	Set/clear to enable/disable VEVENT
5	MPARAIN	Set/clear to enable/disable PARAIN

* **INTCLR** (Write Only)

BIT	NAME	FUNCTION
0	CSCLINT	Write 1 to this bit to clear SCLINT in INTVECT
1	CADCINT	Write 1 to this bit to clear ADCINT in INTVECT
2	CDDC1INT	Write 1 to this bit to clear DDC1INT in INTVECT
3	CSOAIN	Write 1 to this bit to clear SOAIN in INTVECT
4	CVEVENT	Write 1 to this bit to clear VEVENT in INTVECT
5	CPARAIN	Write 1 to this bit to clear PARAIN in INTVECT

***PARAL**: Parabola interrupt generator register, low byte (Read/Write)

BIT	NAME	FUNCTION
0	PARA0	PARAIN period register bit 0
1	PARA1	PARAIN period register bit 1
2	PARA2	PARAIN period register bit 2
3	PARA3	PARAIN period register bit 3
4	PARA4	PARAIN period register bit 4
5	PARA5	PARAIN period register bit 5
6	PARA6	PARAIN period register bit 6
7	PARA7	PARAIN period register bit 7

***PARAH**: Parabola interrupt generator register, high byte (Read/Write)

BIT	NAME	FUNCTION
0	PARA8	PARAIN period register bit 8
1	PARA9	PARAIN period register bit 9
2	PARA10	PARAIN period register bit 10
3	PARA11	PARAIN period register bit 11
4	PARA12	PARAIN period register bit 12



***SOARL**: SOA register, low byte (Read/Write)

BIT	NAME	FUNCTION
0	SL0	SOA Low register bit 0
1	SL1	SOA Low register bit 1
2	SL2	SOA Low register bit 2
3	SL3	SOA Low register bit 3
4	SL4	SOA Low register bit 4
5	SL5	SOA Low register bit 5
6	(OVL)	OVL = 1: current H count larger than SOARL, for test
7	(OVH)	OVH = 1: current H count smaller than SOARH, for test

***SOARH**: SOA register, high byte (Read/Write)

BIT	NAME	FUNCTION
0	SH0	SOA High register bit 0
1	SH1	SOA High register bit 1
2	SH2	SOA High register bit 2
3	SH3	SOA High register bit 3
4	SH4	SOA High register bit 4
5	SH5	SOA High register bit 5
6	(ADCSTRT)	ADCSTRT bit status, for test
7	(WDTQ10)	Watch Dog Timer, bit 10, for test

* ADC	Result of the A-to-D conversion.
* DAC0~DAC8	8-bit PWM static DAC register.
* DAC9~DAC10	8-bit PWM dynamic DAC register.
* WDTCLR	Watchdog-timer-clear register, without real hardware but an address. Writing any value to WDTCLR will clear the watchdog timer.
* SOACL	Safe-Operation-Area Clear register, without real hardware but an address. Writing any value to SOACL will clear the SOAINT.
* DDC1	DDC1 latch buffer.
* S1CON	SIO1 control register.
* S1STA	SIO1 status register.
* S1DAT	SIO1 data register.
* S1ADR1, S1ADR2	SIO1 address registers.
* S2CON	SIO2 control register.
* S2STA	SIO2 status register.
* S2DAT	SIO2 data register.
* S2ADR1, S2ADR2	SIO2 address registers.

6.4. Modified Timer 0 & Timer 1

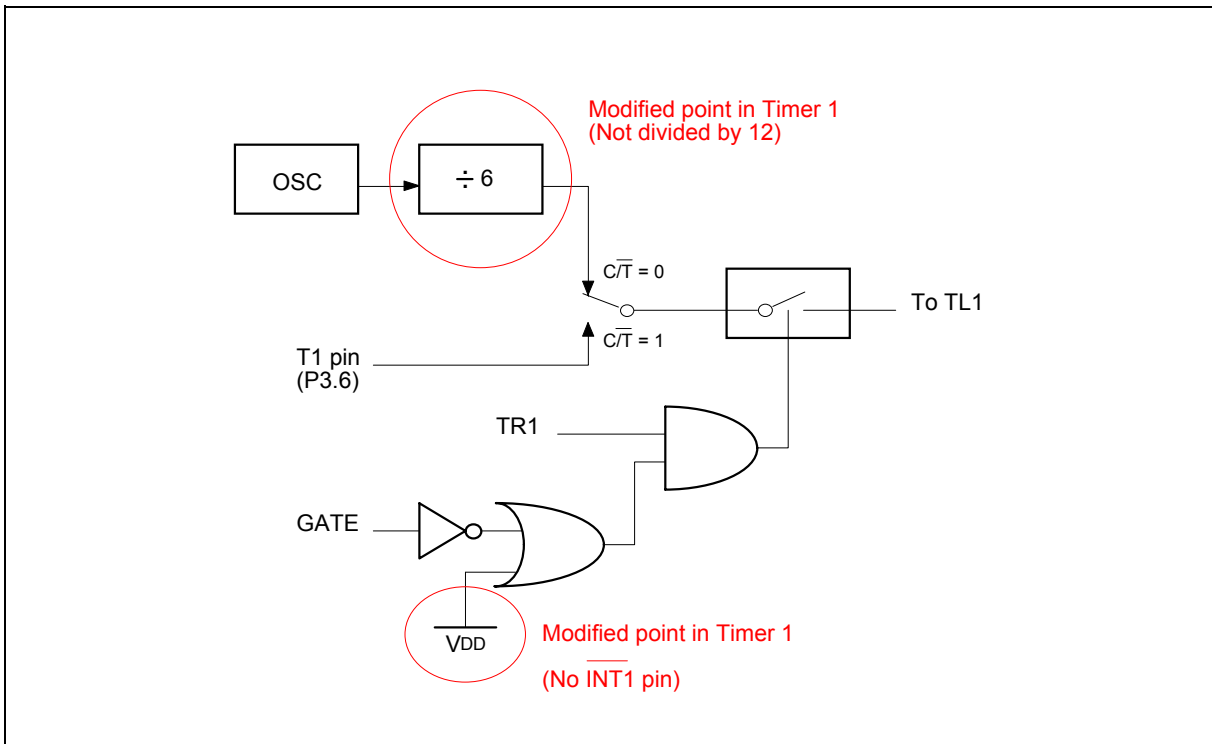
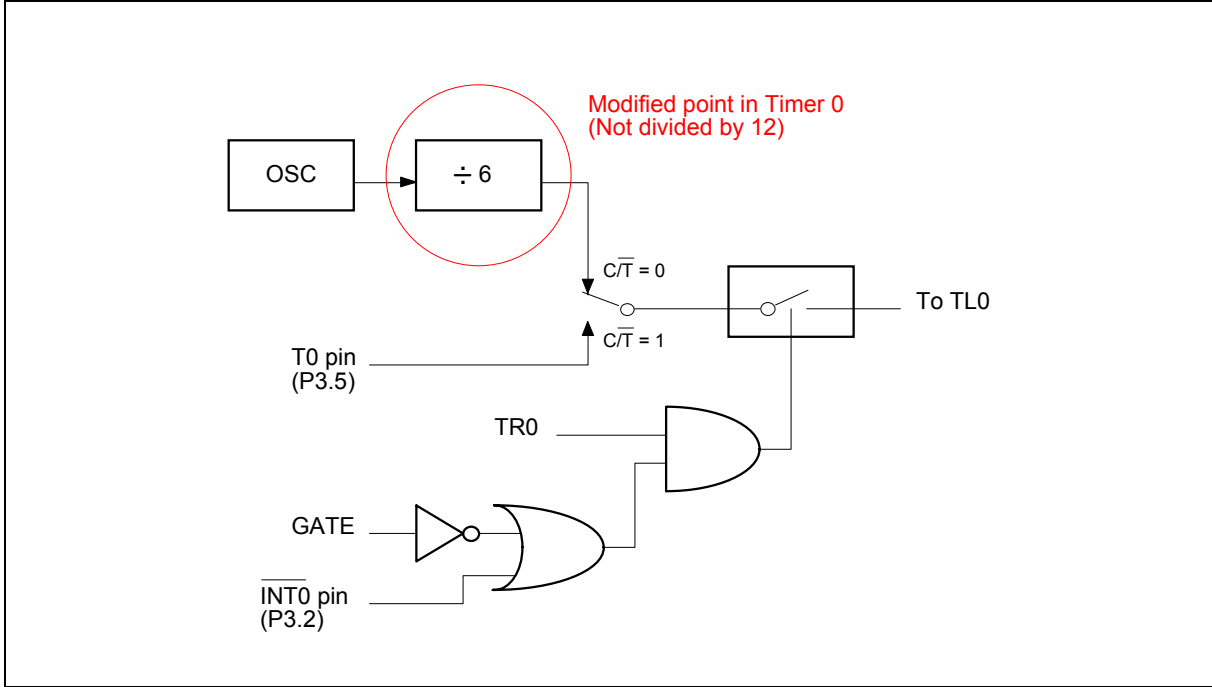



6.5. DDC1/SIO1 and SIO2 Ports

1. DDC1/SIO1 port

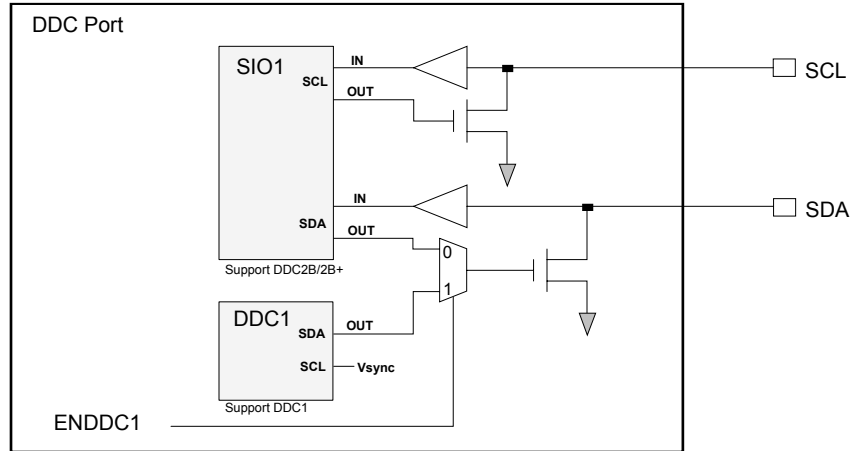

- ENDDC1 = 1, used as DDC1 (Display Data Channel) port:
To support DDC1, use Vsync signal for shift clock and P3.0 (SDA) for data output.
- ENDDC1 = 0, used as SIO1 port:
To support DDC2B/2B+/2Bi/2AB, use P3.1 (SCL) for serial clock and P3.0 (SDA) for serial data.

SCLINT interrupt is generated when SCL (P3.1) has a high-to-low transition and then keeps at low for $16 \times 1/F_{osc}$.

Fosc	8 MHz	10 MHz
SCL low	2 μ S	1.6 μ S

2. SIO2 port:

- To support DDC2B/2B+/2Bi/2AB, use P4.4 (SCL) for serial clock and P4.5 (SDA) for serial data.

DDC1 Port

The DDC1 is a serial output port that supports DDC1 communication. To enable the DDC1 port, ENDDC1 (bit 3 of CTRL1) should be set to '1'. Once previous eight data bits in the shift register and one null bit (the 9th bit) are shifted out to the SDA sequentially on each **rising edge** of the V_{IN} signal, the DDC1 control circuit loads the next data byte from the latch buffer (the DDC1 register) to the shift register and generates a DDC1INT signal to the CPU. In the interrupt service routine, the S/W should fetch the next byte of EDID data and write it to the DDC1 register. If ENDDC1 is cleared, the shift register is stopped, and the SDA output is kept high. The bit DDC1B9 (bit 4 of CTRL2) decides the 9th bit in a DDC transmission. If DDC1B9 is set, the 9th bit will be '1', otherwise '0'.



a) Control Registers

a-1) The Address Registers, S1ADR1, S1ADR2

The SIO1 is equipped with two address registers: S1ADR1 & S1ADR2. The CPU can read from and write to these two 8-bit, directly addressable SFRs. The content of these registers are irrelevant when SIO1 is in master modes. In the slave modes, the seven most significant bits must be loaded with the MCU's own address. The SIO1 hardware will react if either of the addresses is matched.

7	6	5	4	3	2	1	0
X	X	X	X	X	X	X	-

|----- Own Slave Address -----|

a-2) The Data Register, S1DAT

This register contains a byte of serial data to be transmitted or a byte which has just been received. The CPU can read from or write to this 8-bit directly addressable SFR while it is not in the process of shifting a byte. This occurs when SIO1 is in a defined state and the serial interrupt flag (SI) is set. Data in S1DAT remains stable as long as SI is set. While data is being shifted out, data on the bus is simultaneously being shifted in; S1DAT always contains the last data byte present on the bus. Thus, in the event of lost arbitration, the transition from master transmitter to slave receiver is made with the correct data in S1DAT.

7	6	5	4	3	2	1	0
SD7	SD6	SD5	SD4	SD3	SD2	SD1	SD0

|<----- Shift direction -----|

S1DAT and the acknowledge bit form a 9-bit shift register, the acknowledge bit is controlled by the SIO1 hardware and cannot be accessed by the CPU. Serial data is shifted through the acknowledge bit into S1DAT on the rising edges of serial clock pulses on the SCL line. When a byte has been shifted into S1DAT, the serial data is available in S1DAT, and the acknowledge bit (ACK or NACK) is returned by the control logic during the ninth clock pulse. Serial data is shifted out from S1DAT on the falling edges of SCL clock pulses, and is shifted into S1DAT on the rising edges of SCL clock pulses.

a-3) The Control Register, S1CON

The CPU can read from and write to this 8-bit, directly addressable SFR. Two bits are affected by the SIO1 hardware: the SI bit is set when a serial interrupt is requested, and the STO bit is cleared when a STOP condition is present on the bus. The STO bit is also cleared when ENS1 = "0".

7	6	5	4	3	2	1	0
CR2	ENS1	STA	STO	SI	AA	CR1	CR0

ENS1, the SIO1 Enable Bit

ENS1 = "0": When ENS1 is "0", the SDA and SCL outputs are in a high impedance state. SDA and SCL input signals are ignored, SIO1 is in the not addressed slave state, and STO bit in S1CON is forced to "0". No other bits are affected. P3.0 (SDA) and P3.1 (SCL) may be used as open drain I/O ports.

ENS1 = "1": When ENS1 is "1", SIO1 is enabled. The P3.0 and P3.1 port latches must be set to logic 1.



STA, the START Flag

STA = "1": When the STA bit is set to enter a master mode, the SIO1 hardware checks the status of I2C bus and generates a START condition if the bus is free. If the bus is not free, then SIO1 waits for a STOP condition and generates a START condition after a delay. If STA is set while SIO1 is already in a master mode and one or more bytes are transmitted or received, SIO1 transmits a repeated START condition. STA may be set at any time. STA may also be set when SIO1 is an addressed slave.

STA = "0": When the STA bit is reset, no START condition or repeated START condition will be generated.

STO, the STOP Flag

STO = "0": When the STO bit is set while SIO1 is in a master mode, a STOP condition is transmitted to the I2C bus. When the STOP condition is detected on the bus, the SIO1 hardware clears the STO flag. In a slave mode, the STO flag may be set to recover from an bus error condition. In this case, no STOP condition is transmitted to the I2C bus. However, the SIO1 hardware behaves as if a STOP condition has been received and switches to the defined not addressed slave receiver mode. The STO flag is automatically cleared by hardware. If the STA and STO bits are both set, then a STOP condition is transmitted to the I2C bus if SIO1 is in a master mode (in a slave mode, SIO1 generates an internal STOP condition which is not transmitted). SIO1 then transmits a START condition.

SI, the Serial Interrupt Flag

SI = "1": When a new SIO1 state is present in the S1STA register, the SI flag is set by hardware, and, if the EA and ES bits (in IE register) are both set, a serial interrupt is requested. The only state that does not cause SI to be set is state F8H, which indicates that no relevant state information is available. When SI is set, the low period of the serial clock on the SCL line is stretched, and the serial transfer is suspended. A high level on the SCL line is unaffected by the serial interrupt flag. SI must be cleared by software.

SI = "0": When the SI flag is reset, no serial interrupt is requested, and there is no stretching on the serial clock on the SCL line.

AA, the Assert Acknowledge Flag

AA = "1": If the AA flag is set, an acknowledge (low level to SDA) will be returned during the acknowledge clock pulse on the SCL line when: 1) The own slave address has been received. 2) A data byte has been received while SIO1 is in the master receiver mode. 3) A data byte has been received while SIO1 is in the addressed slave receiver mode.

AA = "0": If the AA flag is reset, a not acknowledge (high level to SDA) will be returned during the acknowledge clock pulse on SCL when: 1) A data has been received while SIO1 is in the master receiver mode. 2) A data byte has been received while SIO1 is in the addressed slave receiver mode.

CR0, CR1 and CR2, the Clock Rate Bits

These three bits determine the serial clock frequency when SIO1 is in a master mode. It is not important when SIO1 is in a slave mode. In the slave modes, SIO1 will automatically synchronize with any clock frequency up to 100 KHz.



Bit Freq. (KHz) @Fosc					
CR2	CR1	CR0	8 MHz	10 MHz	Fosc Divided By
0	0	0	55	69	144
0	0	1	62	78	128
0	1	0	71	89	112
0	1	1	83	104	96
1	0	0	16	20	496
1	0	1	105	131	76
1	1	0	166	208	48

a-4) The Status Register, S1STA

S1STA is an 8-bit read-only register. The three least significant bits are always 0. The five most significant bits contain the status code. There are 23 possible status codes. When S1STA contains F8H, no serial interrupt is requested. All other S1STA values correspond to defined SIO1 states. When each of these states is entered, a status interrupt is requested (SI = 1). A valid status code is present in S1STA one machine cycle after SI is set by hardware and is still present one machine cycle after SI has been reset by software.

In addition, state 00H stands for a Bus Error. A Bus Error occurs when a START or STOP condition is present at an illegal position in the format frame. Examples of illegal positions are during the serial transfer of an address byte, a data byte or an acknowledge bit.

b) Operating Modes

The four operating modes are: Master/Transmitter, Master/Receiver, Slave/Transmitter and Slave/Receiver. Bits STA, STO and AA in S1CON decide the next action the SIO1 hardware will take after SI is cleared. When the next action is completed, a new status code in S1STA will be updated and SI will be set by hardware in the same time. Now, the interrupt service routine is entered (if the SI_interrupt is enabled), the new status code can be used to decide which appropriate service routine the software is to branch. Data transfers in each mode are shown in the following figures.

*** Legend for the following four figures:

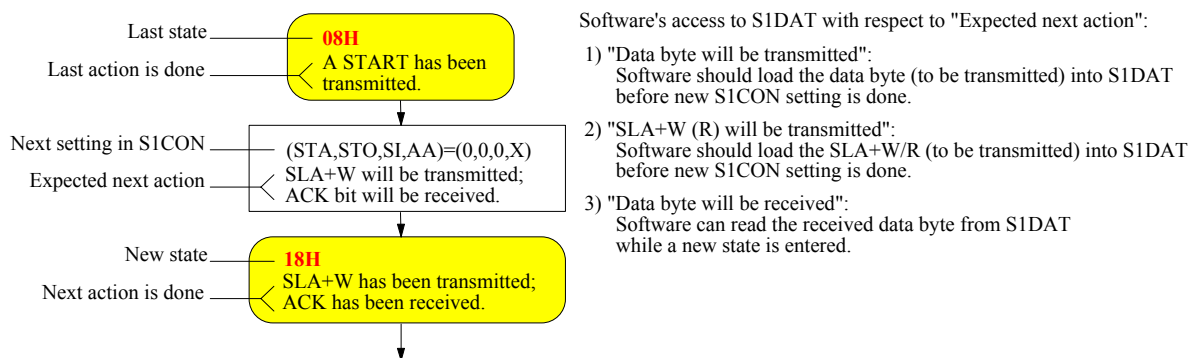

Master/Receiver Mode

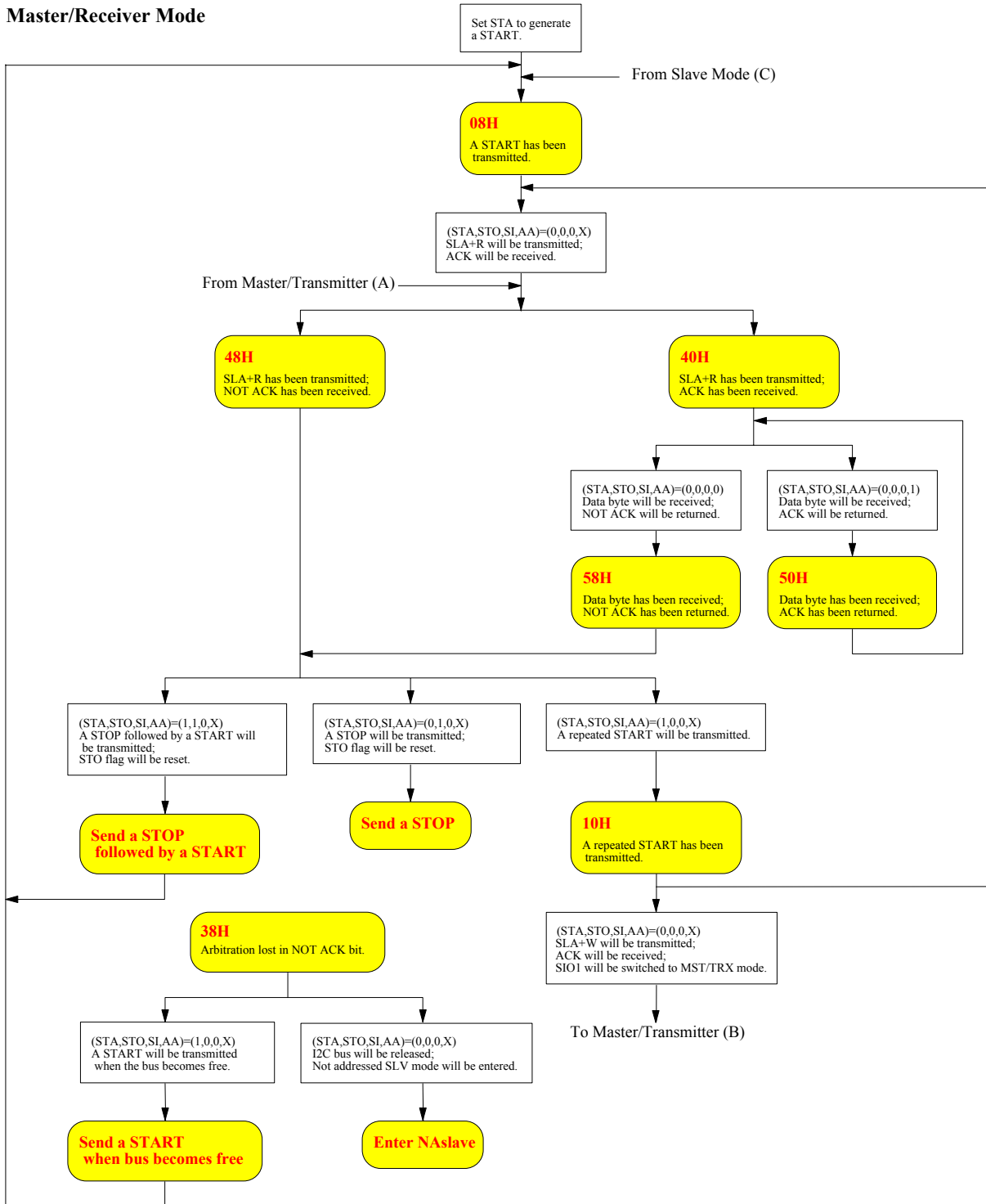

Slave/Transmitter Mode

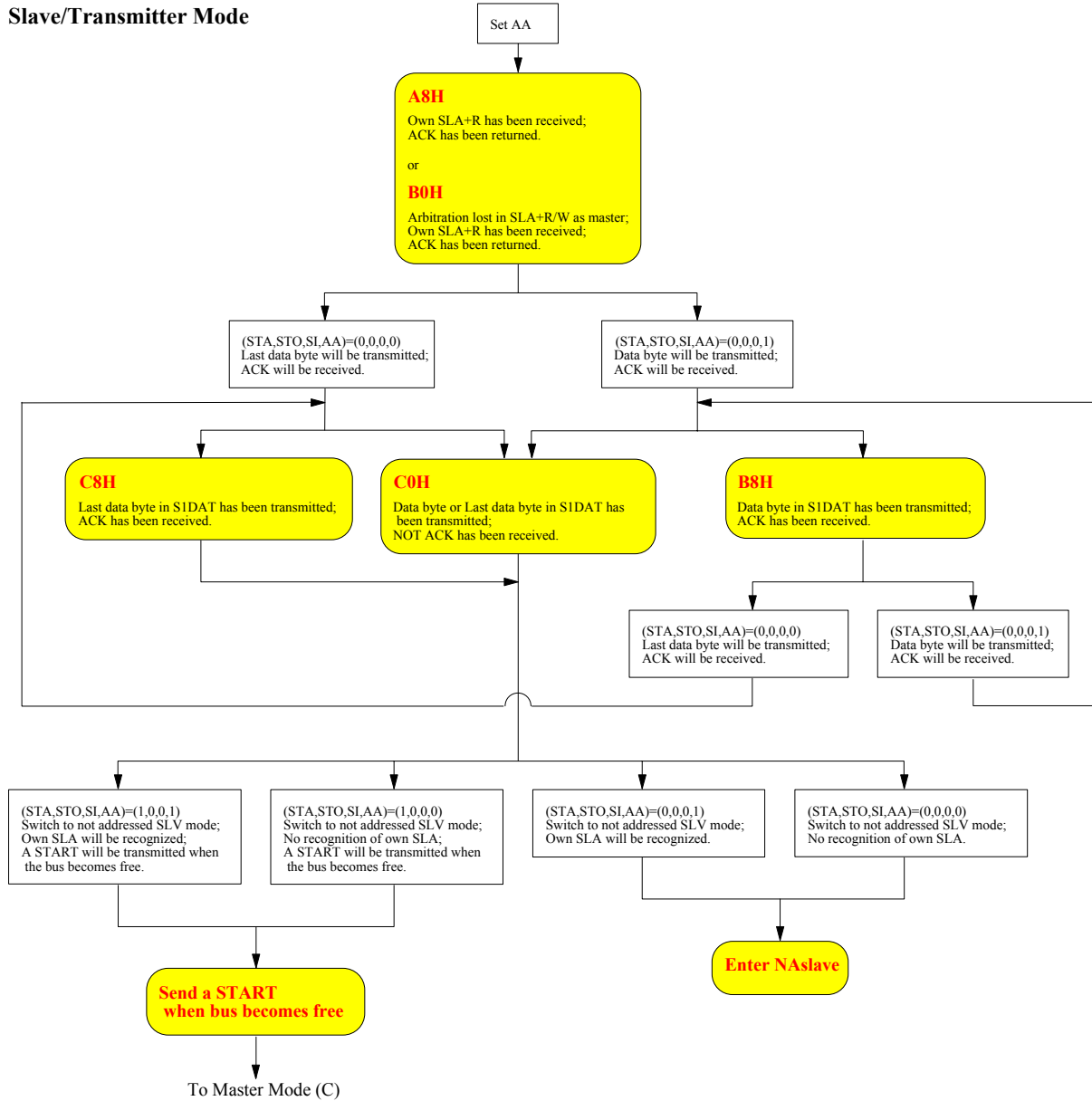

Slave/Receiver Mode

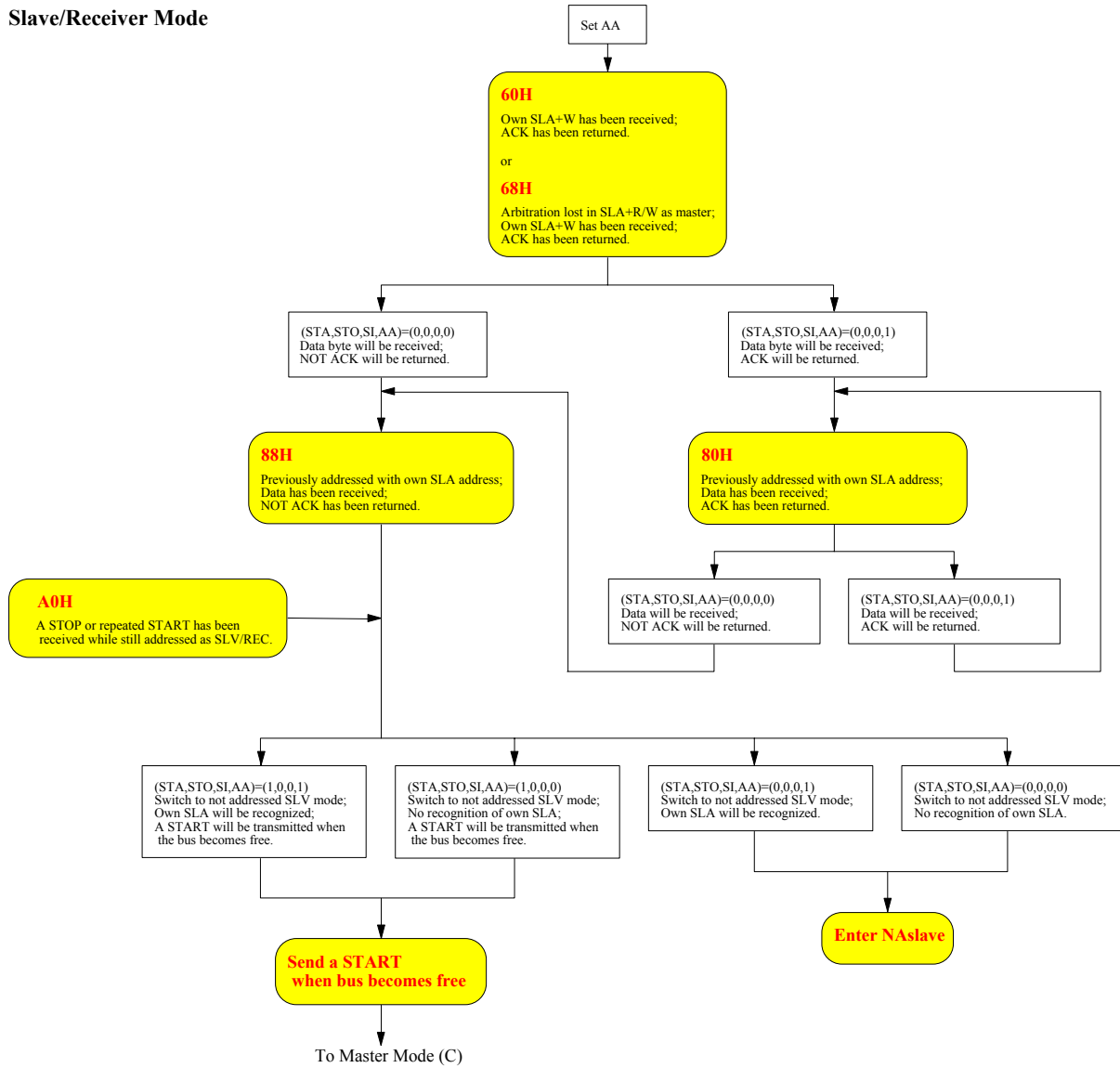



6.6. Parabola Interrupt Generator

The parabola interrupt generator is a 13-bit auto-reload timer, which generates an interrupt to the CPU periodically for software to load the parabola waveform data to the dynamic DACs (DAC8–DAC10). The software should calculate the value of the PARAH and PARAL registers by: $(V_{count} \times 16) \div \text{segment number}$. The segment number is the number of integration segments between two Vsync pulses. The interrupt interval is programmable:

- Time base = $1/F_{osc}$
- Programmable interrupt period = Time base \times (PARAH \times 256 + PARAL + 1)
- Maximum period = Time base \times 8192

Note: Zero value in [PARAH, PARAL] is inhibited.

A-to-D Converter (ref. Application Note in Appendix A.)

One 4-bit Analog-to-Digital Converter.

- Conversion time = $(6/F_{osc}) \times 128 \text{ sec.}$
- 7 channels selected by an analog multiplexer

(ADCS2, ADCS1, ADCS0)	(0, 0, 0)	(0, 0, 1)	(0, 1, 0)	(0, 1, 1)	(1, 0, 0)	(1, 0, 1)	(1, 1, 0)
Selected Channel	ADC0	ADC1	ADC2	ADC3	ADC4	ADC5	ADC6

The conversion of the ADC is started by setting bit ADCSTRT in CTRL1 by software. When the conversion is completed, the ADCSTRT bit is cleared by hardware automatically, and the ADCINT bit in INTVECT is set by hardware at the same time if MADCINT in INTMSK is set.

PWM DACs

Eight 8-bit Static DACs: DAC0–DAC7

- The PWM frequency $F_{PWM} = F_{osc} \div 255$
- The duty cycle of the PWM output = Register value $\div 255$
- The DC voltage after the low pass filter = $V_{CC} \times \text{duty cycle}$

Static DAC application circuit:

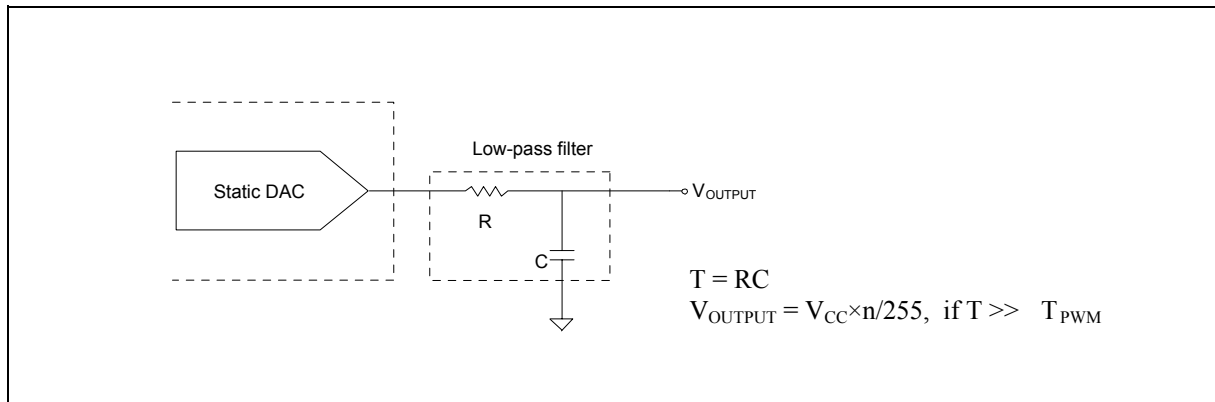



Three 8-bit Dynamic DACs: DAC8–DAC10

The dynamic DACs are especially used to generate parabola waveform for geometric compensation, or to be used as static DACs. Dynamic DAC application circuit:

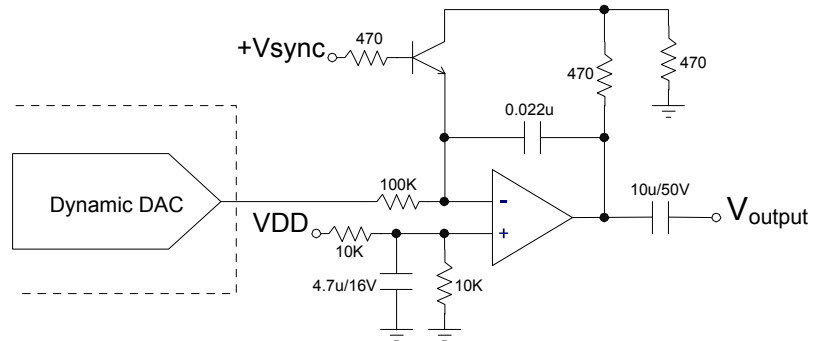

The following types of distortion can be compensated:

1. H size distortion:

a. PinCushion Correction (Amplitude)



b. Trapezoid (Keystone)



c. CBOW (Quarter Width)



d. PinCushion Correction (Corner)

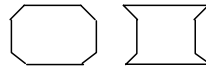

e. S Curve



The PCC amplitude can be compensated against V size adjustment automatically.

The Trapzoid can be compensated against V center adjustment automatically.

2. H center distortion:

a. Pin balance (Bow)

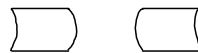

b. Key balance (Tilt)

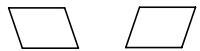

c. Corner balance

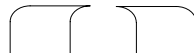



6.7. Sync Processor

Polarity Detector

The H/V polarity is detected automatically and can be known from HPOL bit (HFCOUNTH.7) and VPOL bit (VFCOUNTH.7).

Fosc	10 MHz
Max. H+V width	$(64/F_{osc}) \times 62$ (counter overflow) = 396.8 μ S
Max. V width	$(2048/F_{osc}) \times 2$ = 409.6 μ S

Sync Separator

The Vsync is separated from the composite sync automatically, without any software effort.

Fosc	10 MHz
Min. V width & Max. H width	$(1/F_{osc}) \times 64$ = 6.4 μ S

Horizontal & Vertical Frequency Counter

There are two 12-bit counters which can count H and V frequency automatically. When VEVENT (Vsync frequency counter timeout) interrupt happens, the count value values are latched into the counter registers (HFCOUNTH, HFCOUNTL, VFCOUNTH and VFCOUNTL). And then the S/W may read the count value (H_{COUNT} and V_{COUNT}) from the counter registers to calculate the H and V frequency by the formulas listed below.

V frequency:

The resolution of V frequency counter: $VRESOL = (1/F_{osc}) \times 64$.

The V frequency: $VFREQ = 1/(V_{COUNT} \times VRESOL)$.

The lowest V frequency can be detected: $F_{osc} \div 262144$. (38.1Hz @ F_{osc} = 10 MHz)

H frequency:

The resolution of H frequency counter: $HRESOL = (1/F_{osc}) \div 8$.

The H frequency: $HFREQ = 1/(H_{COUNT} \times HRESOL)$.

The lowest H frequency can be detected: $F_{osc} \div 512$. (19.5 KHz @ F_{osc} = 10 MHz)

Dummy Frequency Generator

The Dummy H and V frequencies are generated for factory burn-in or showing warning message while there are no input frequency.

(HDUMS1, HDUMS0)	(0, 0)	(0, 1)	(1, 0)	(1, 1)
FdummyH	$F_{osc}/(8 \times 4 \times 8)$	$F_{osc}/(8 \times 2 \times 8)$	$F_{osc}/(8 \times 3 \times 8)$	$F_{osc}/(8 \times 5 \times 8)$
Hsync width	$(8 \times 4)/F_{osc}$	$(8 \times 2)/F_{osc}$	$(8 \times 3)/F_{osc}$	$(8 \times 5)/F_{osc}$

VDUMS	0	1
FdummyV	$F_{dummyH}/512$	$F_{dummyH}/1024$
Vsync width	$8/F_{dummyH}$	$16/F_{dummyH}$

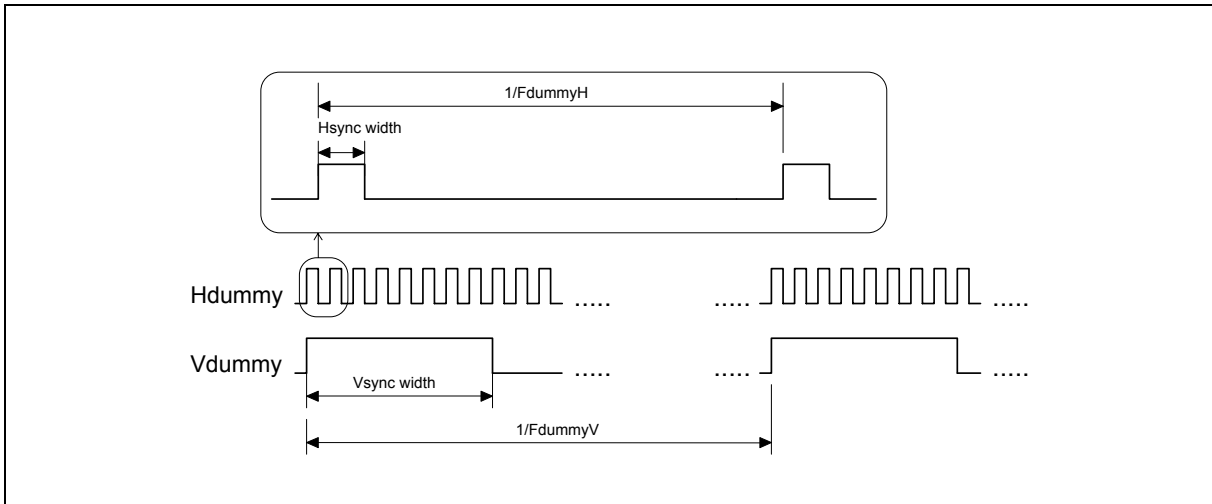

For Fosc = 10 MHz:

(HDUMS1, HDUMS0)	(0, 1)		(1, 0)		(0, 0)		(1, 1)	
	FdummyH	78.125 KHz		52.083 KHz		39.063 KHz		31.250 KHz
Hsync width	1.6 μS		2.4 μS		3.2 μS		4.0 μS	
VDUMS	0	1	0	1	0	1	0	1
FdummyV	152.6 Hz	76.3 Hz	101.7 Hz	50.9 Hz	76.3 Hz	38.1 Hz	61.0 Hz	30.5 Hz

H-clamp Pulse Generator

1. Leading edge/Trailing edge selectable.

* HCES = 0: select leading edge

* HCES = 1: select trailing edge

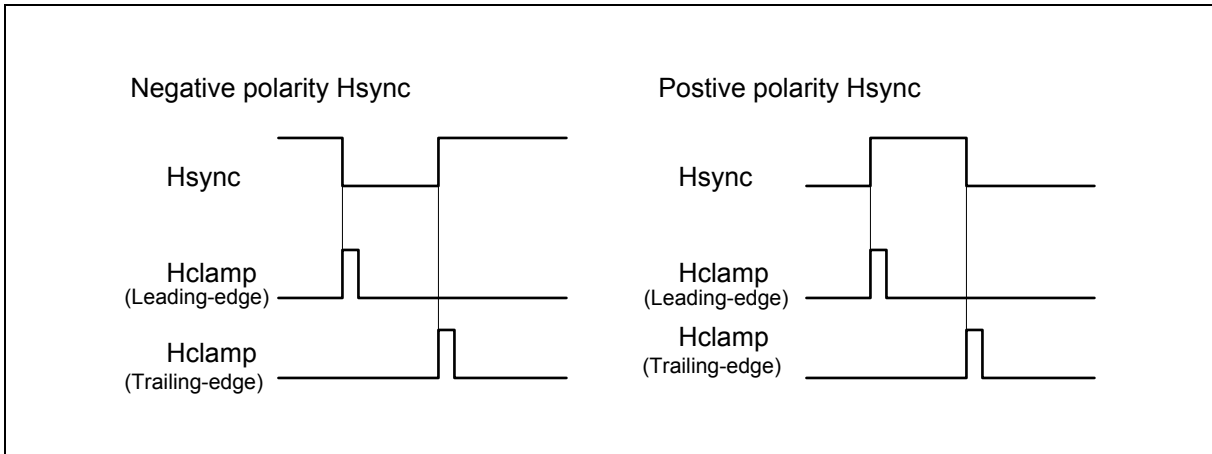



2. Pulse width selectable.

For Fosc = 10 MHz:

	HCWS = 0	HCWS = 1
Pulse Width	500–600 nS	900–1000 nS

Safe Operation Area (SOA) Interrupt

Upper boundary frequency = $F_{OSC} / [8 \times SOARH]$

Lower boundary frequency = $F_{OSC} / [8 \times (SOARL + 1)]$

Function description:

- If the condition, H_{FREQ} lower than the lower boundary freq. or higher than the upper boundary freq., happens twice continuously, the SOAINT will be activated.
- If the HIN is stopped for a certain period, the SOAINT will also be generated.

The no Hsync response time is $512/F_{OSC}$. (e.x., 51.2us for 10 MHz)

- If SOAHDIS = 1, then no upper boundary frequency.

Half Hsync Output

When ENHFO (bit 0 of CTRL3) is set, P4.7 (HFO) will output the same or half frequency from P4.0 (HFI). The divide-by-two operation is done at the falling edge of HFI signal when HFO_HALF (bit 3 of CTRL3) is set. The polarity of HFO is specified by HF_POL (bit 2 of CTRL3).

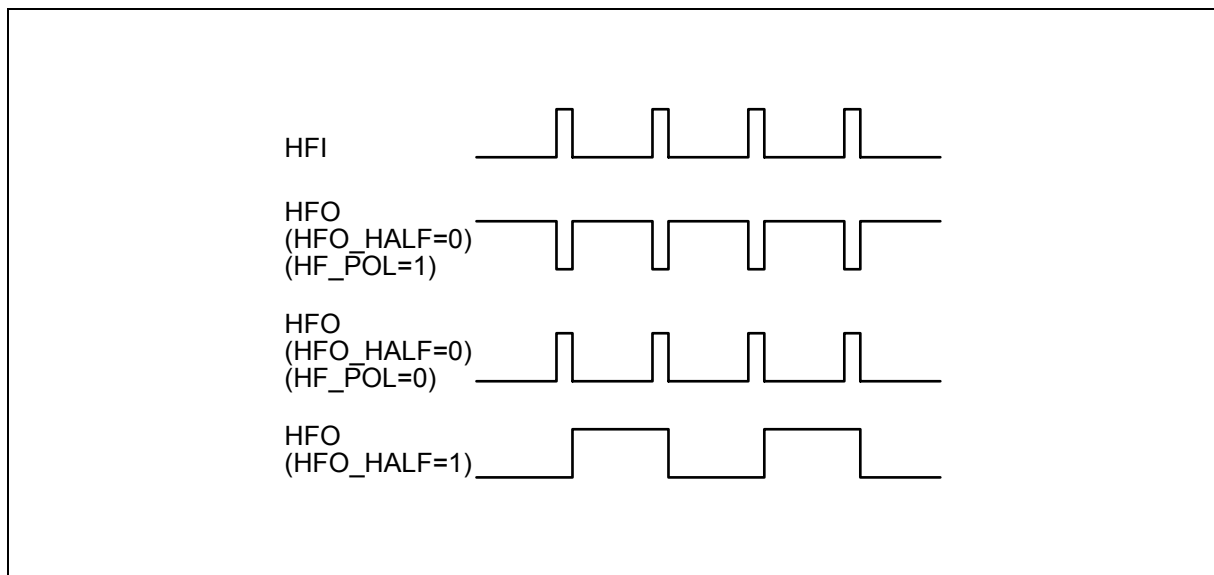



6.8. Interrupts

The five interrupt sources are listed as below.

	SOURCE	VECTOR ADDRESS	DESCRIPTON	PRIORITY WITHIN A LEVEL
1	IE0	0003H	Interrupt 0 edge detected	Highest
2	TF0	000BH	Timer 0 overflow	
3	IE1	0013H	Miscellaneous interrupts ^{*1}	
4	TF1	001BH	Timer 1 overflow	
5	SI1+SI2	002BH	SIO1 or SIO2 interrupt	Lowest

Note: *1: SCLINT + ADCINT + DDC1INT + SOAINT + VEVENT + PARAINIT.

The miscellaneous interrupts at vector address 0013H is driven by the following six sources, which are:

- (1) SCLINT: when high-to-low transition on SCL-pin,
- (2) ADCINT: when A-to-D conversion completion,
- (3) DDC1INT: when DDC1 data byte transmitted (after 9 clock pulses from VIN) in the DDC port,
- (4) SOAINT: when SOA activated,
- (5) VEVENT: on every Vsync pulse or vertical frequency counter overflow,
- (6) PARAINIT: when parabola timer timeout.

If IE1 interrupt occurs, it is necessary for the programmer to read the INTVECT register to tell where the interrupt request comes. These sources can be masked individually by clearing their corresponding bits in the INTMSK register. To clear any of these interrupt flags, just write a '1' to the corresponding bit in the INTCLR.

The interrupt enable bits and priority control bits for these five main sources are listed as below.

	INTERRUPT FLAG	ENABLE BIT	PRIORITY CONTROL BIT
1	IE0	IE.0 & IE.7	IP.0
2	TF0	IE.1 & IE.7	IP.1
3	IE1	IE.2 & IE.7	IP.2
4	TF1	IE.3 & IE.7	IP.3
5	SI+SI2	IE.5 & IE.7	IP.5

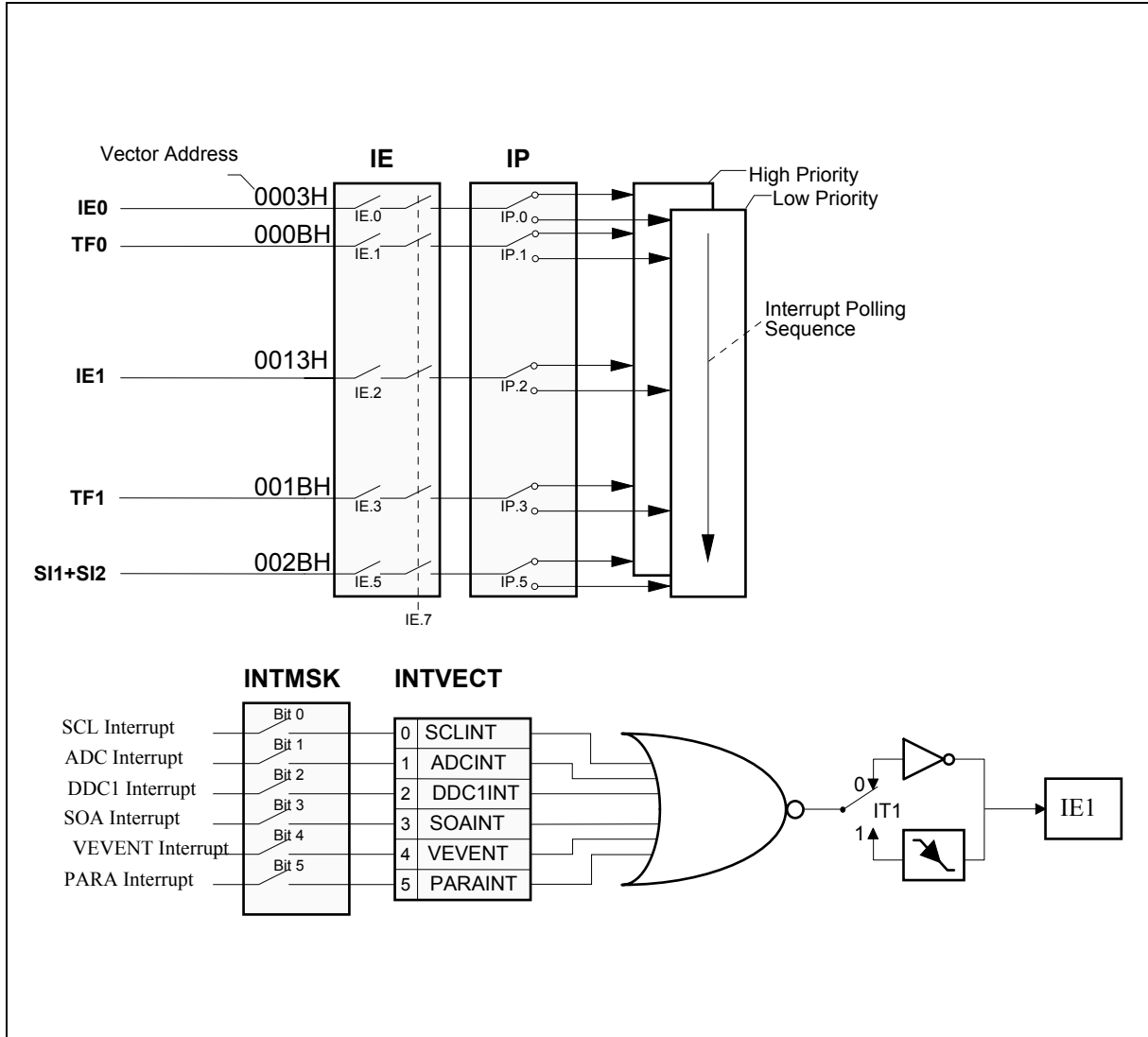

6.9. Reset Circuit- Power-low Detector & Watchdog Timer

The reset signals come from the following three sources:

1. External reset input (active low)
2. Power low detect
3. Hardware Watchdog Timer

The power-low detection circuit generates a reset signal once the VCC falls below **3.5V** for above 10 μ S or falls below **1.8V**, and the reset signal is released after VCC goes up to **4.3V**.

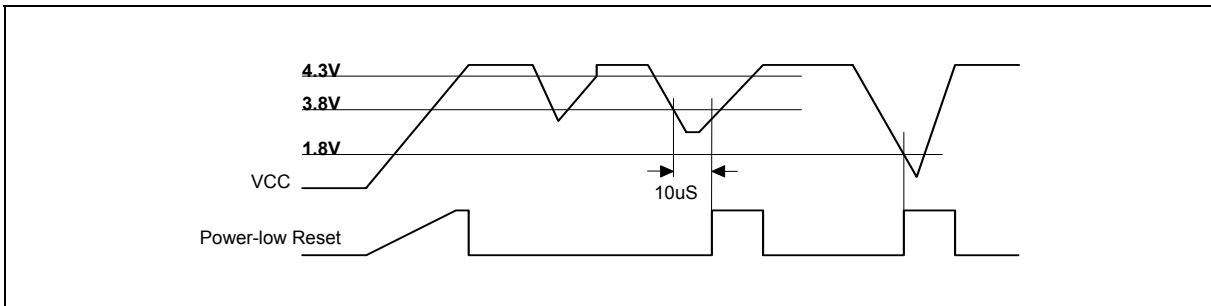

The purpose of a watchdog timer is to reset the CPU if the user program fails to reload the watchdog timer within a reasonable period of time known as the "watchdog interval". The clock source of the watchdog timer comes from the internal system clock. It can be enabled/disabled by set/clear WDTEN (bit 5 of CTRL2). For debug purpose, if the WDT reset or power low reset occur, the $\overline{\text{RESET}}$ pin will be pulled low internally. The pulled-low duration due to WDT reset is about $60/F_{osc}$ sec. The block diagram of the reset circuitry is shown as below.

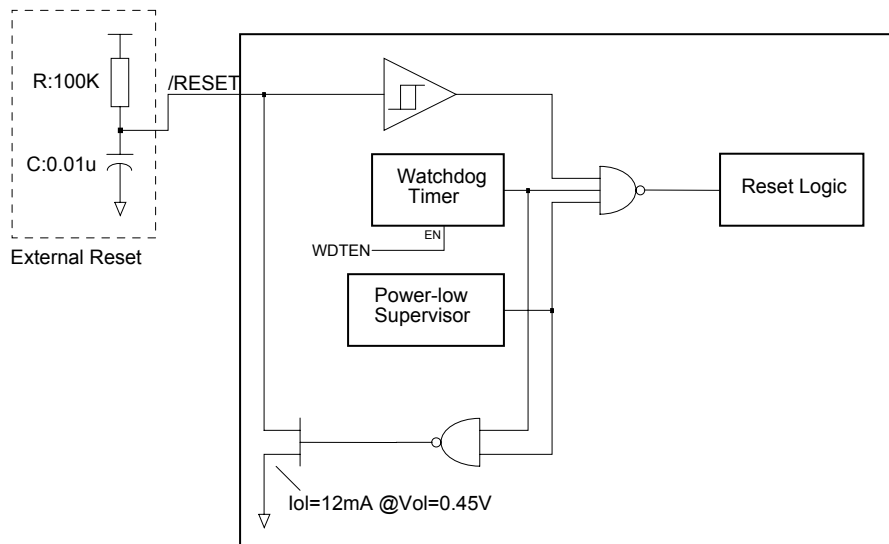



7. ELECTRICAL CHARACTERISTICS

7.1. Absolute Maximum Ratings

PARAMETER	SYMBOL	MIN.	MAX.	UNIT
DC Power Supply	V _{DD}	-0.3	+7.0	V
Input Voltage	V _{IN}	V _{SS} -0.3	V _{DD} +0.3	V
Input Current	I _{IN}	-100	+100	mA
Operating Temperature	T _A	0	70	°C
Storage Temperature	T _{ST}	-55	150	°C

Note: Exposure to conditions beyond those listed under Absolute Maximum Ratings may adversely affect the life and reliability of the device.

7.2. D.C. Characteristics

V_{DD}-V_{SS} = 5V ±10%, T_A = 25°C, F_{osc} = 10 MHz, unless otherwise specified.

PARAMETER	SYM.	SPECIFICATION			UNIT	TEST CONDITIONS
		MIN.	TYP.	MAX.		
Operating Voltage	V _{DD}	4.5	5	5.5	V	All function must pass!
Operating Current	I _{DD}	-	-	30	mA	No load, V _{DD} = 5.5V
Power-down Current	I _{PD}	-	-	100	μA	No load, V _{DD} = 5.5V
Input						
Input Current P2, P3.2–P3.4, P4.0	I _{IN1}	-75 -10	- -	-10 +10	μA	V _{DD} = 5.5V, V _{IN} = 0V V _{DD} = 5.5V, V _{IN} = 5.5V
Input Current $\overline{\text{RESET}}$	I _{IN2}	-300 -10	- -	-100 +10	μA	V _{DD} = 5.5V, V _{IN} = 0V V _{DD} = 5.5V, V _{IN} = 5.5V
Input Leakage Current P1, P2.4–P2.7(S.F. enabled) P3.0, P3.1, P3.5–P3.7, P4.4, P4.5 H _{IN} , V _{IN}	I _{LK}	-10	-	+10	μA	V _{DD} = 5.5V, 0V < V _{IN} < V _{DD}
Logical 1-to-0 Transition Current P2, P3.2–P3.4	I _{TL}	-650	-	-100	μA	V _{DD} = 5.5V, V _{IN} = 2.0V
Input Low Voltage P1, P2, P3 (except P3.0 & P3.1), P4.0, H _{IN} , V _{IN} , $\overline{\text{RESET}}$, OSCIN	V _{IL1}	0	-	0.8	V	V _{DD} = 4.5V



D.C. Characteristics, continued

PARAMETER	SYM.	SPECIFICATION			UNIT	TEST CONDITIONS
		MIN.	TYP.	MAX.		
Input Low Voltage P3.0, P3.1, P4.4, P4.5	V _{IL2}	0	-	0.3 V _{DD}	V	V _{DD} = 4.5V
Input High Voltage P1, P2, P3 (except P3.0 & P3.1), P4.0, H _{IN} , V _{IN} , <u>RESET</u>	V _{IH1}	2.0	-	V _{DD} +0.2	V	V _{DD} = 5.5V
Input High Voltage P3.0, P3.1, P4.4, P4.5	V _{IH2}	0.7 V _{DD}	-	V _{DD} +0.2	V	V _{DD} = 5.5V
Input High Voltage OSCIN	V _{IH3}	3.5	-	V _{DD} +0.2	V	V _{DD} = 5.5V
Output						
Output Low Voltage P1.0, P1.1, <u>RESET</u>	V _{OL1}	-	-	0.45	V	V _{DD} = 4.5V I _{OL} = +12 mA
Output Low Voltage P3.0, P3.1, P4.4, P4.5	V _{OL2}	-	-	0.45	V	V _{DD} = 4.5V I _{OL} = +8 mA
Output Low Voltage P1 (except P1.0 & P1.1) P2, P3 (except P3.0–P3.2) P4 (except P4.4 & P4.5)	V _{OL3}	-	-	0.45	V	V _{DD} = 4.5V I _{OL} = +4 mA
Output Low Voltage P3.2, OSCOUT	V _{OL4}	-	-	0.45	V	V _{DD} = 4.5V I _{OL} = +0.8 mA
Output High Voltage P2, P3.2–P3.4	V _{OH1}	2.4	-	-	V	V _{DD} = 4.5V I _{OH} = -100 μA
Output High Voltage P4 (except P4.4 & P4.5)	V _{OH2}	2.4	-	-	V	V _{DD} = 4.5V I _{OH} = -4 mA
Special Function Output High Voltage P2.0–P2.3, P3.3, P3.4	V _{OH3}	2.4	-	-	V	V _{DD} = 4.5V I _{OH} = -4 mA
Output High Voltage OSCOUT	V _{OH4}	2.4	-	-	V	V _{DD} = 4.5V I _{OH} = -3 mA

Notes:

- *1. RESET has an internal pull-up resistor of about 30 KΩ.
- *2. P2 and P3.2–P3.4 can source a transition current when they are being externally driven from 1 to 0. The transition current reaches its maximum value when V_{IN} is approximately 2V.
- *3. P3.0, P3.1, P4.4, P4.5, H_{IN}, V_{IN} and RESET are Schmitt trigger inputs.



8. APPENDIX A. APPLICATION NOTE FOR USAGE OF ADC

To use the ADC, users should pay attention to the following points:

- (1) According to the absolute maximum ratings, the input voltage should not exceed $V_{DD} + 0.3V$, especially for the ADC channel pins (P2.4–P2.7 & P3.5–P3.7). If a voltage over $V_{DD} + 0.3V$ exists on any of these ADC channel pins, the AD conversion will fail.
- (2) Owing to the CMOS process, the ADC curve of some chip might differ from those of the others. So, before using the ADC, the S/W should do the ADC calibration described below.

Step 1. Set (ADCS2, ADCS1, ADCS0, ADCcal) = (1, 1, 1, 0) and then do AD conversion to get the ADC value for the on-chip **0.948V** input. Suppose it is **A**.

Step 2. Set (ADCS2, ADCS1, ADCS0, ADCcal) = (1, 1, 1, 1) and then do AD conversion to get the ADC value for the on-chip **2.924V** input. Suppose it is **B**.

Step 3. Because the ADC curve in the usable range is linear, any **V** and **X** should meet the formula:

$$(X-A)/(V-0.948) = (B-A)/(2.924-0.948),$$

where **V** is the key voltage (designed by users and thus known) and **X** is its predicted ADC value. Then, we can get $X = A + (V-0.948)(B-A)/(2.924-0.948)$, regardless of $V > 0.948V$ or $< 0.948V$. (Of course, some effort should be paid in S/W to find **X**.)

Step 4. Suppose there are N keys used, the N predicted ADC values for these keys can be found.

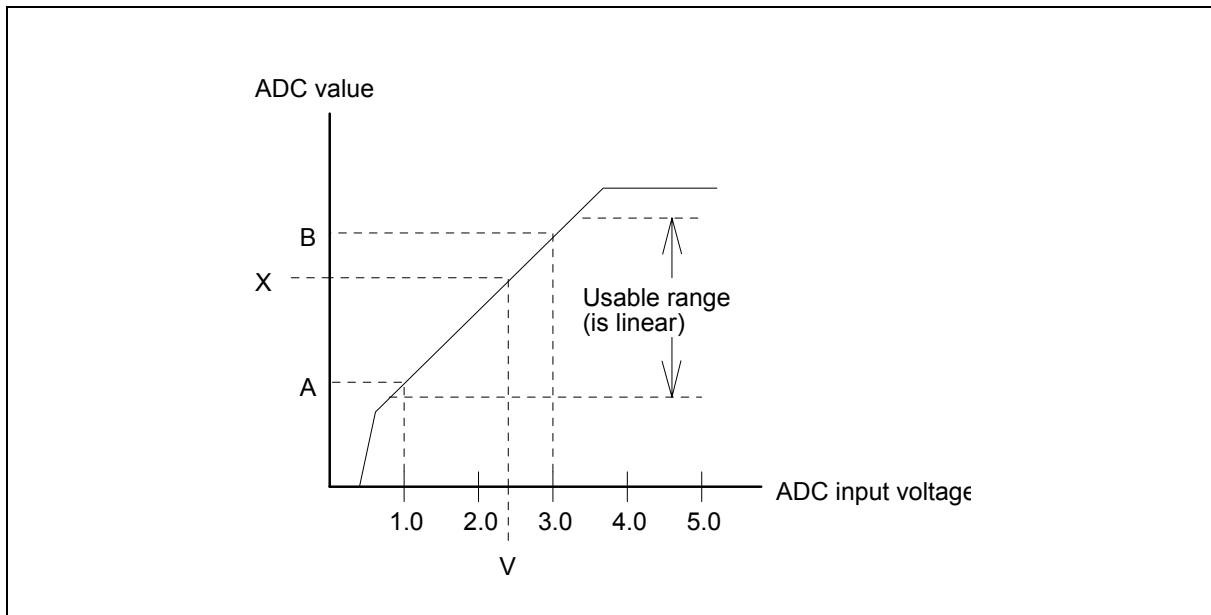

After finding these N predicted ADC values, the S/W can recognize which key is pressed by comparing the ADC value of this key with the set of predicted values (found previously).

**** Note: To get the exact on-chip calibration voltages (0.948V and 2.924V), the V_{DD} should be 5.0V as close as possible.**



Test strategy before shipping:

- (1) $V_i = 0V \Rightarrow ADC < 20$
- (2) $V_i = 0.8V \Rightarrow ADC > 25$
- (3) $V_i = 3.2V \Rightarrow ADC < 248$
- (4) $V_i = 4.4V \Rightarrow ADC = 255$
- (5) $0.8V < V_i < 3.2V$, 25 points (step 0.1V) will be tested. All test points should be recognized correctly.

Comment:

- a. (1) guarantees 0V input can be recognized (ADC value < 20).
- b. (4) guarantees 5V input can be recognized (ADC value = 255).
- c. (2), (3) and (5) guarantee linear (with 4 bits at least) within the usable range (0.8V to 3.2V).

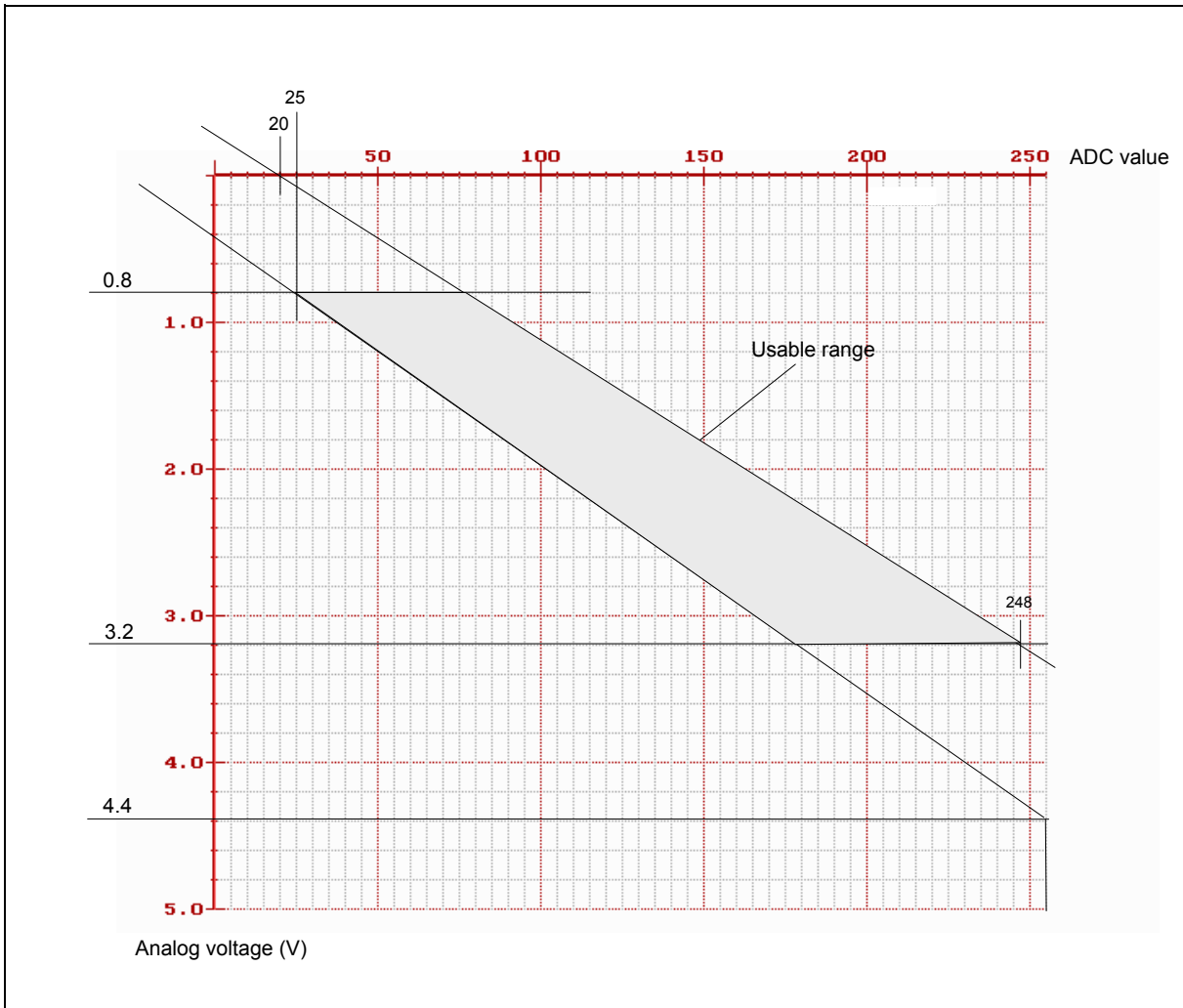



9. PACKAGE DIMENSIONS

9.1. 32-pin P-DIP

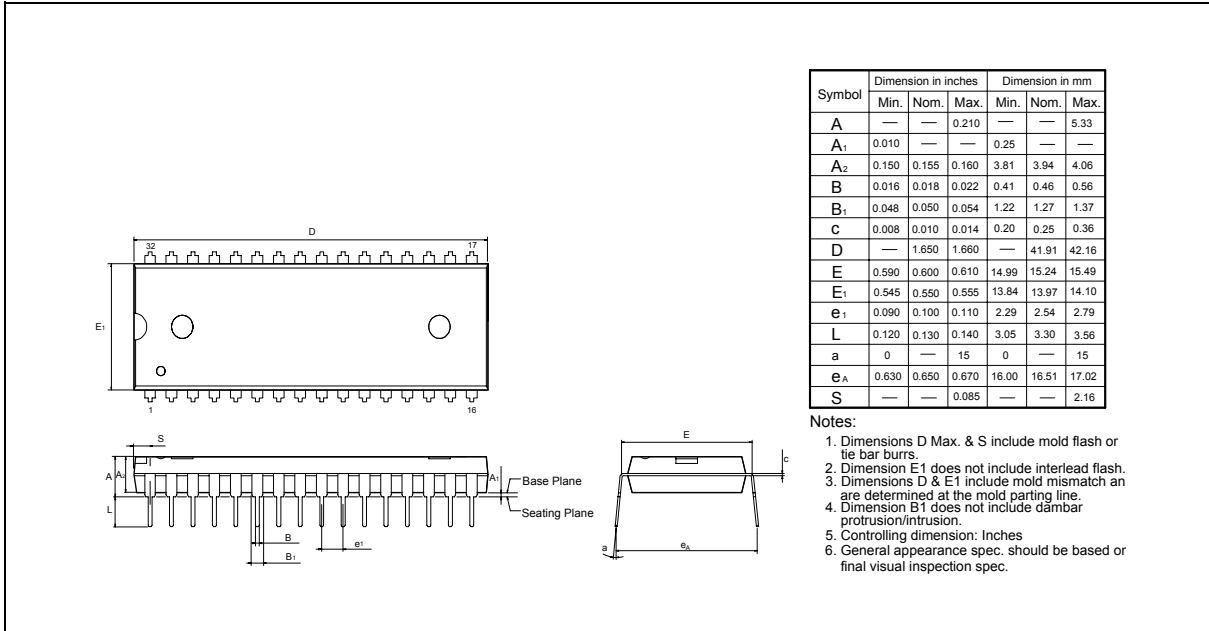

9.2. 40-pin DIP

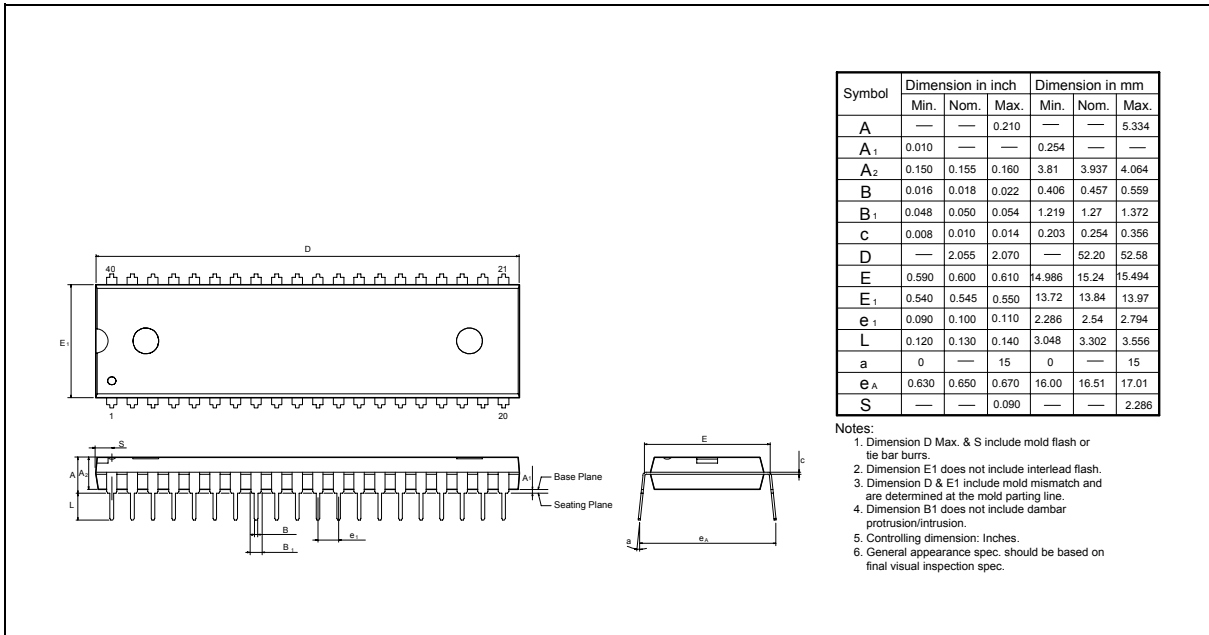

Package Dimensions, continued

9.3. 44-pin PLCC

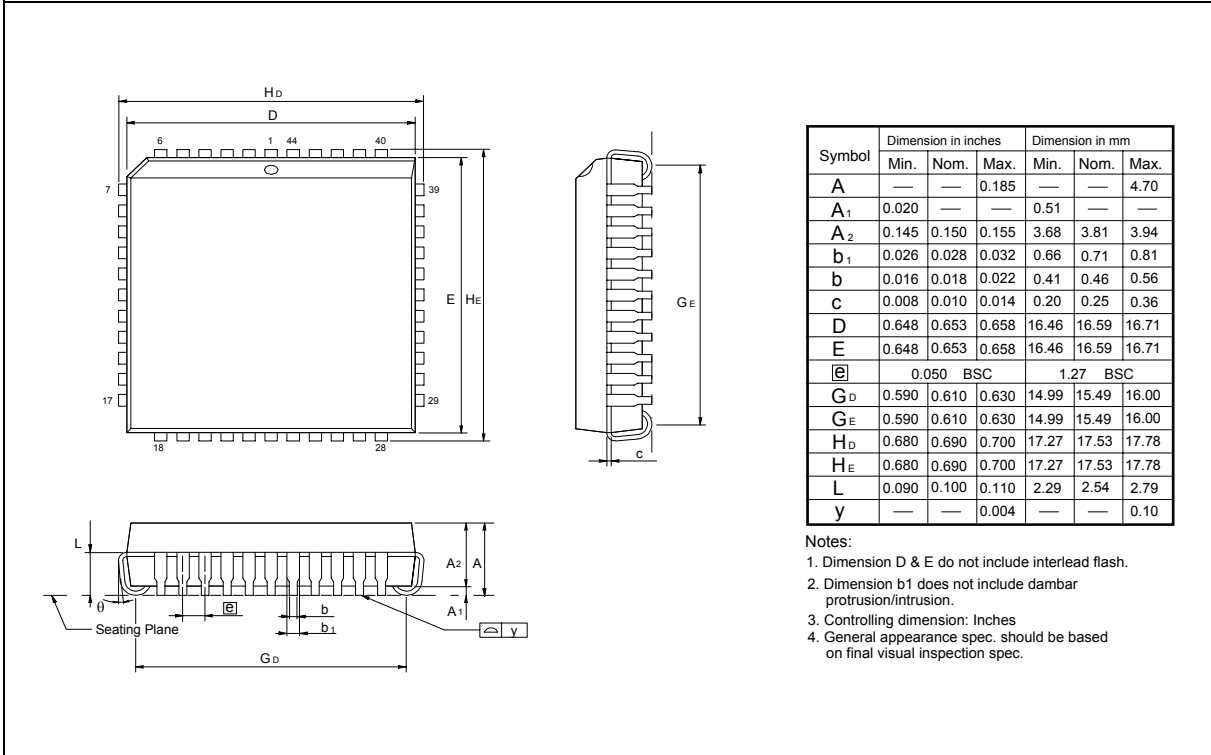

Symbol	Dimension in inches			Dimension in mm		
	Min.	Nom.	Max.	Min.	Nom.	Max.
A	—	—	0.185	—	—	4.70
A ₁	0.020	—	—	0.51	—	—
A ₂	0.145	0.150	0.155	3.68	3.81	3.94
b ₁	0.026	0.028	0.032	0.66	0.71	0.81
b	0.016	0.018	0.022	0.41	0.46	0.56
c	0.008	0.010	0.014	0.20	0.25	0.36
D	0.648	0.653	0.658	16.46	16.59	16.71
E	0.648	0.653	0.658	16.46	16.59	16.71
E	0.050	BSC		1.27		BSC
G _D	0.590	0.610	0.630	14.99	15.49	16.00
G _E	0.590	0.610	0.630	14.99	15.49	16.00
H _D	0.680	0.690	0.700	17.27	17.53	17.78
H _E	0.680	0.690	0.700	17.27	17.53	17.78
L	0.090	0.100	0.110	2.29	2.54	2.79
y	—	—	0.004	—	—	0.10

- Notes:
1. Dimension D & E do not include interlead flash.
 2. Dimension b₁ does not include dambar protrusion/intrusion.
 3. Controlling dimension: Inches
 4. General appearance spec. should be based on final visual inspection spec.



10. REVISION HISTORY

VERSION	DATE	PAGE	DESCRIPTION
A1	August, 2004	-	Initial issued



Headquarters
 No. 4, Creation Rd. III,
 Science-Based Industrial Park,
 Hsinchu, Taiwan
 TEL: 886-3-5770066
 FAX: 886-3-5665577
<http://www.winbond.com.tw/>

Taipei Office
 9F, No.480, Rueiguang Rd.,
 Neihu District, Taipei, 114,
 Taiwan, R.O.C.
 TEL: 886-2-8177-7168
 FAX: 886-2-8751-3579

Winbond Electronics Corporation America
 2727 North First Street, San Jose,
 CA 95134, U.S.A.
 TEL: 1-408-9436666
 FAX: 1-408-5441798

Winbond Electronics Corporation Japan
 7F Daini-ueno BLDG, 3-7-18
 Shinyokohama Kohoku-ku,
 Yokohama, 222-0033
 TEL: 81-45-4781881
 FAX: 81-45-4781800

Winbond Electronics (Shanghai) Ltd.
 27F, 2299 Yan An W. Rd. Shanghai,
 200336 China
 TEL: 86-21-62365999
 FAX: 86-21-62365998

Winbond Electronics (H.K.) Ltd.
 Unit 9-15, 22F, Millennium City,
 No. 378 Kwun Tong Rd.,
 Kowloon, Hong Kong
 TEL: 852-27513100
 FAX: 852-27552064

*Please note that all data and specifications are subject to change without notice.
 All the trade marks of products and companies mentioned in this data sheet belong to their respective owners.*