

# NCN1154MUTGEVB

## NCN1154 DP3T USB 2.0 High Speed Audio Switch Evaluation Board User's Manual

Prepared by: Bertrand RENAUD  
On Semiconductor



ON Semiconductor®

<http://onsemi.com>

### EVAL BOARD USER'S MANUAL

#### OVERVIEW

The NCN1154 is a DP3T switch for combined true-ground audio, USB 2.0 high speed data, and UART applications. It allows portable systems to use a single port to pass either USB data or audio signals from an external headset. The switch is capable of passing signals with negative voltages as low as 2 V below ground.

The NCN1154 features shunt resistors on the audio ports. These resistors are switched in when the audio channel is off

and provide a safe path to ground for any charge that may build up on the audio lines.

This reduces Pop & Click noise in the audio system. The device has an extended  $V_{CC}$  range which can operate off  $V_{CC}$  up to 4.2 V while passing true ground audio signals down to -2 V.

The NCN1154 is housed in a space saving, ultra low profile 1.7 x 2.0 x 0.5 mm 12 pin DFN package.

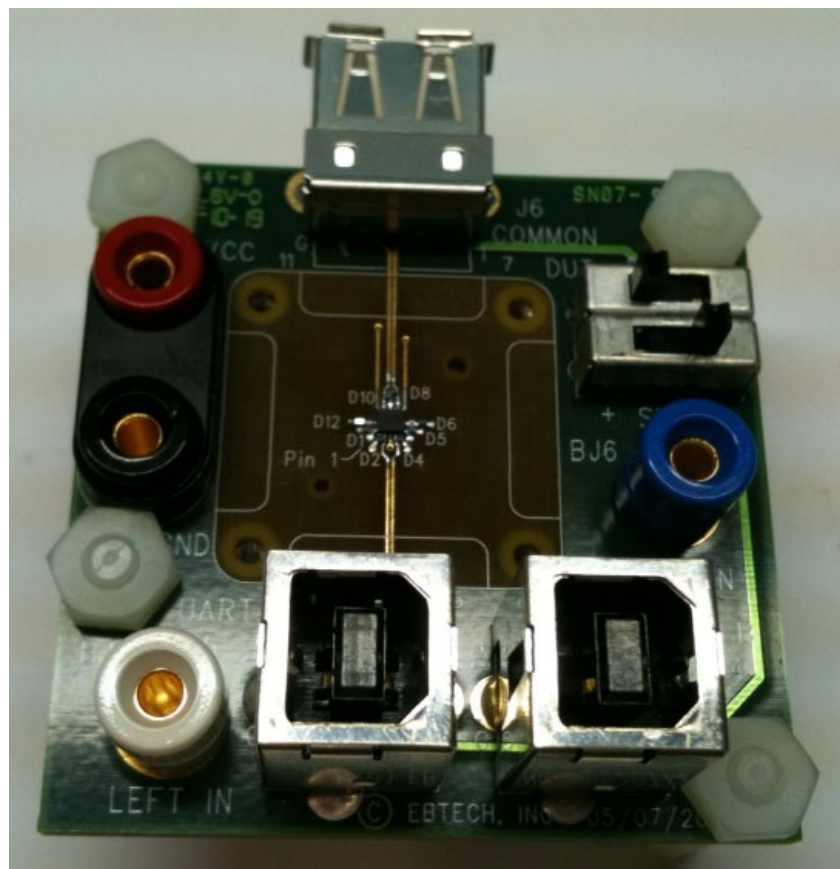

Figure 1. Board Picture

# NCN1154MUTGEVB

## NCN1154 – BOARD SCHEMATIC

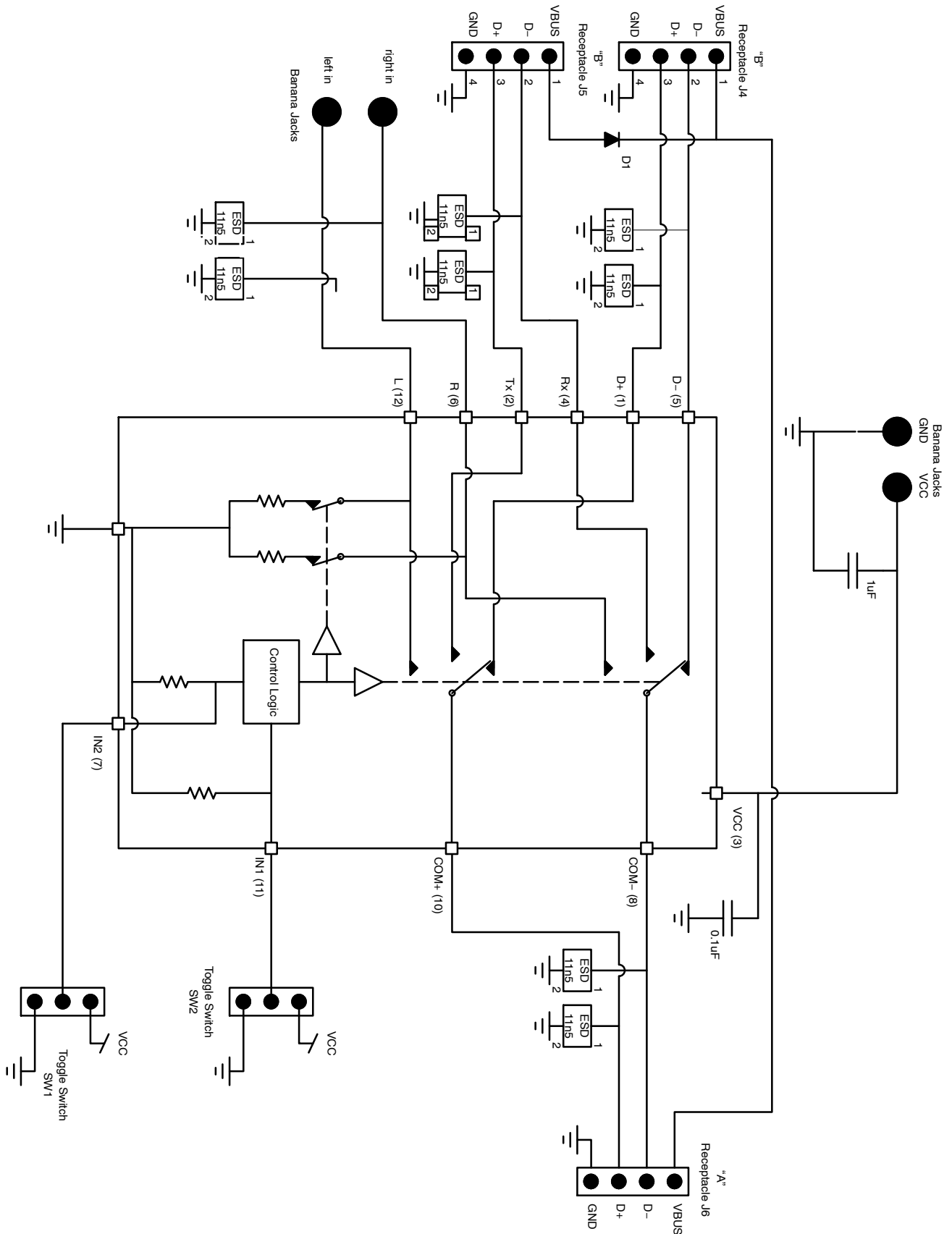

Figure 2. Board Schematic

# NCN1154MUTGEVB

## NCN1154 – BOARD CONNECTIONS

### SUPPLY

Symbol	Description
VCC, GND	This is the positive and the return connection for power supply (Pins 3 and 9).

### SETUP

Symbol	Description
SW1	This is the toggle switch for IN2 (Pin 7).
SW2	This is the toggle switch for IN1 (Pin 11).

### SIGNALS

Symbol	Description
COMMON	This standard USB connector is the common data and audio lines (Pins 8 and 10).
USB	This USB connector Male A type is the high speed USB signaling path (Pins 1 and 5).
UART	This USB connector Male B type is dedicated for Tx and Rx data lines for UART signals (Pins 2 and 4).
LEFT IN	This connector is the left audio signal (Pin 12).
RIGHT IN	This connector is the right audio signal (Pin 6).

# NCN1154MUTGEVB

## NCN1154 – TEST PROCEDURE

### Equipment needed

- Power Supply
- Digital Ohm Meter
- Desktop or Laptop with Windows XP or higher
- USB Key
- USB Headset

### BACKGROUND: IN1 & IN2 TRUTH TABLE

IN1	IN2	D+, D-	R <sub>x</sub> , T <sub>x</sub>	L, R	L, R SHUNT
0	0	Hi Z	Hi Z	Hi Z	ON
0	1	ON	Hi Z	Hi Z	ON
1	0	Hi Z	Hi Z	ON	OFF
1	1	Hi Z	ON	Hi Z	ON

### Test

1. Connect the power supply at 3.6 V from V<sub>CC</sub> to GND. The supply current should be less than 35  $\mu$ A.
2. Turn SW1 and SW2 to G (ground) position  
The impedance measured from COM+ to D+, Tx and L is over 10 M $\Omega$ .  
The impedance measured from COM- to D-, Rx and R is over 10 M $\Omega$ .  
The impedance measured from L & R to GND is closed to 118  $\Omega$ .
3. Turn SW1 to + (V<sub>CC</sub>) and keep SW2 to G (ground)  
The impedance measured from COM+ to D+ is closed to 5.5  $\Omega$ .  
The impedance measured from COM- to D- is closed to 5.5  $\Omega$ .  
The impedance measured from COM+ to Tx and L is over 10 M $\Omega$ .  
The impedance measured from COM- to Rx and R is over 10 M $\Omega$ .  
The impedance measured from L & R to GND is closed to 118  $\Omega$ .
4. Place a USB key connected to COMMON terminal (J6) and connect the USB terminal (J4) to the laptop or desktop.  
The device is being recognized.  
Remove both USB cable and USB key for next measurement.
5. Keep SW1 to + (V<sub>CC</sub>) and turn SW2 to + (V<sub>CC</sub>)  
The impedance measured from COM+ to Tx is closed to 5.5  $\Omega$ .  
The impedance measured from COM- to Rx is closed to 5.5  $\Omega$ .  
The impedance measured from COM+ to D+ and L is over 10 M $\Omega$ .  
The impedance measured from COM- to D- and R is over 10 M $\Omega$ .  
The impedance measured from L & R to GND is closed to 118  $\Omega$ .
6. Place a USB key connected to COMMON terminal (J6) and connect the UART terminal (J5) to the laptop or desktop.  
The device is being recognized.  
Remove both USB cable and USB key for next measurement
7. Turn SW1 to G (ground) and keep SW2 to + (V<sub>CC</sub>)  
The impedance measured from COM+ to L is closed to 3  $\Omega$ .  
The impedance measured from COM- to R is closed to 3  $\Omega$ .  
The impedance measured from COM+ to D+ and Tx is over 5 M $\Omega$ .  
The impedance measured from COM- to D- and Rx is over 5 M $\Omega$ .  
The impedance measured from L & R to GND is over 5 M $\Omega$ .

# NCN1154MUTGEVB

## NCN1154 – COMPONENTS SELECTION

### Input Capacitor

A 0.1  $\mu$ F X5R ceramic capacitor or larger must bypass Vcc input to the ground. This capacitor should be placed as close as possible to this input.

### ESD Diode

These devices have limited built-in ESD protection, an external bi-directional ESD / IEC diode is recommended on COM+ and COM- pin. The demoboard includes six additional ESD diodes for test purpose which are not required by the application. The ESD11N is designed to protect voltage sensitive components that require ultra-low capacitance from ESD and transient voltage events. Excellent clamping capability, low capacitance, low leakage, and fast response time, make these parts ideal for ESD protection on designs where board space is at a premium. Because of its low capacitance, it is suited for use in high frequency designs such as USB 2.0 high speed and antenna line applications.

## NCN1154 – BILL OF MATERIAL

Designator	Qty	Description	Value	Tolerance	Footprint	Manufacturer	Manufacturer Part Number
U1	1	IC, High Speed Switches	NA	NA	UDFN-12	ON Semiconductor	NCN1154
D1, D2, D4, D5, D6, D8, D10, D12	8	ESD Diode	NA	NA	0.6 x 0.3 mm	ON Semiconductor	ESD11N5.0ST5G
C1, C3	1	Ceramic capacitor	10 nF	$\pm 20\%$	0402	AVX Corporation	04023C103KAT2A
C2	1	Ceramic capacitor	1 $\mu$ F	$\pm 20\%$	0603	Murata	GRM188R61C105
J6	1	USB Connector Male ANG Receptable	NA	NA	A Type	Mill-Max	896-43-004-90-000000
J4, J5	2	USB Connector Male VERT Receptable	NA	NA	B Type	Molex/Walldom	67265-2001
BJ6	1	Single Banana	NA	NA	NA	Pomona Electronics	2142-6
BJ12	1	Single Banana	NA	NA	NA	Pomona Electronics	2142-9
BJ	1	Double Banana	NA	NA	NA	Pomona Electronics	2143-0
SW1, SW2	2	Switch	NA	NA	NA	ITT CANNON	OS103011MS8QP1
PCB	1	5.0 x 5.0 x 0.25 mm 2 Layers	NA	NA	NA	Any	EBT1745-01 REV: A

## NCN1154 – PCB LAYOUT GUIDELINES

### Electrical Layout Considerations

Implementing a high speed USD device requires paying attention on USB lines and traces to preserve signal integrity. The demonstration board serves as layout example and can support the design engineers to preserve high speed performances. Electrical layout guidelines are:

- The bypass capacitor must be placed as close as possible to the Vcc input pin for noise immunity.
- The characteristic impedance of each High Speed USB segment must be 45  $\Omega$ .
- All corresponding D+ / D- line segment pairs must be the same length.
- The use of vias to route these signals should be avoided.
- The use of turns or bends to route these signal should be avoided.
- The ground plane of the PCB will be used to determine the characteristics impedance of each line.

# NCN1154MUTGEVB

## NCN1154 – DEMOBOARD PCB LAYOUT

Board Reference: EBT1745-01 REV: A

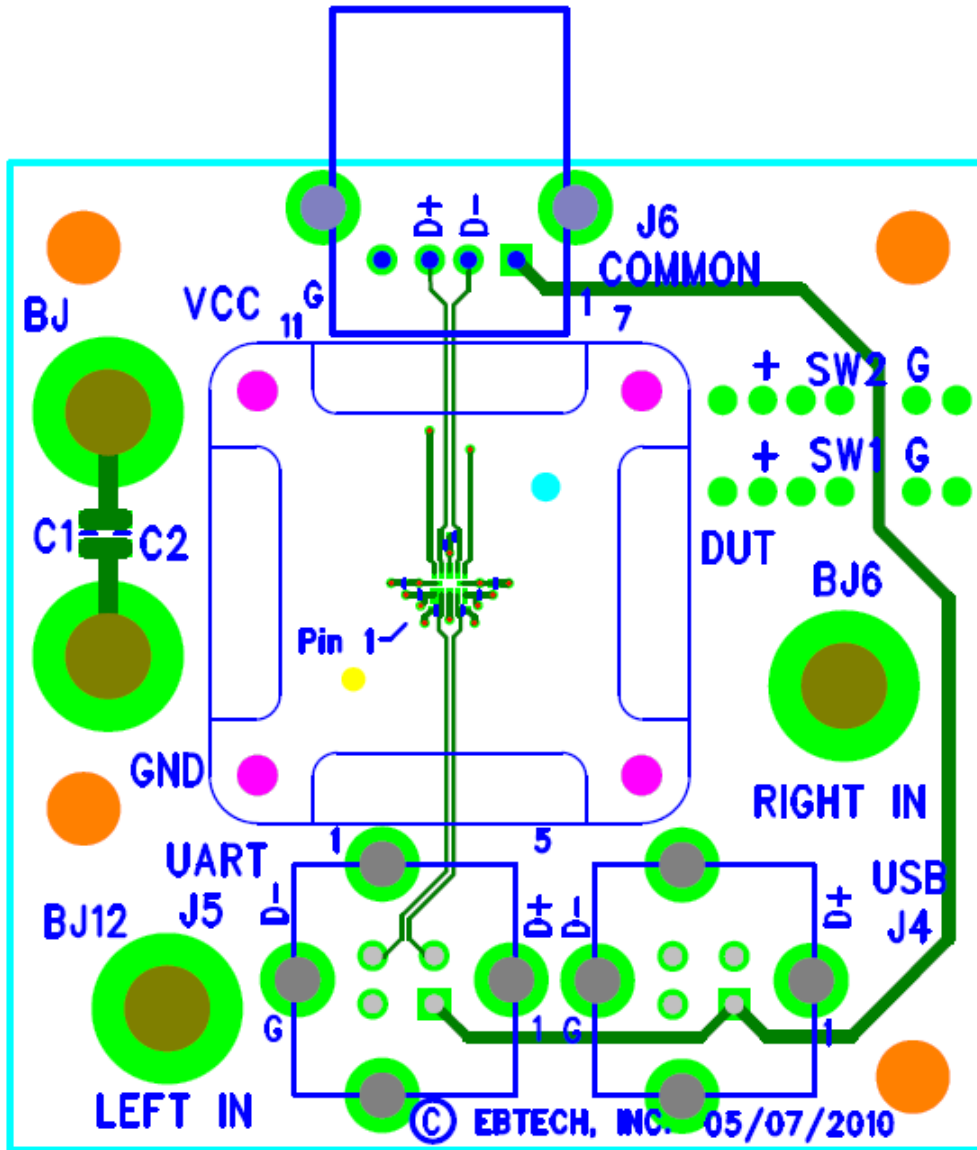

Figure 3. Top Layer Routing

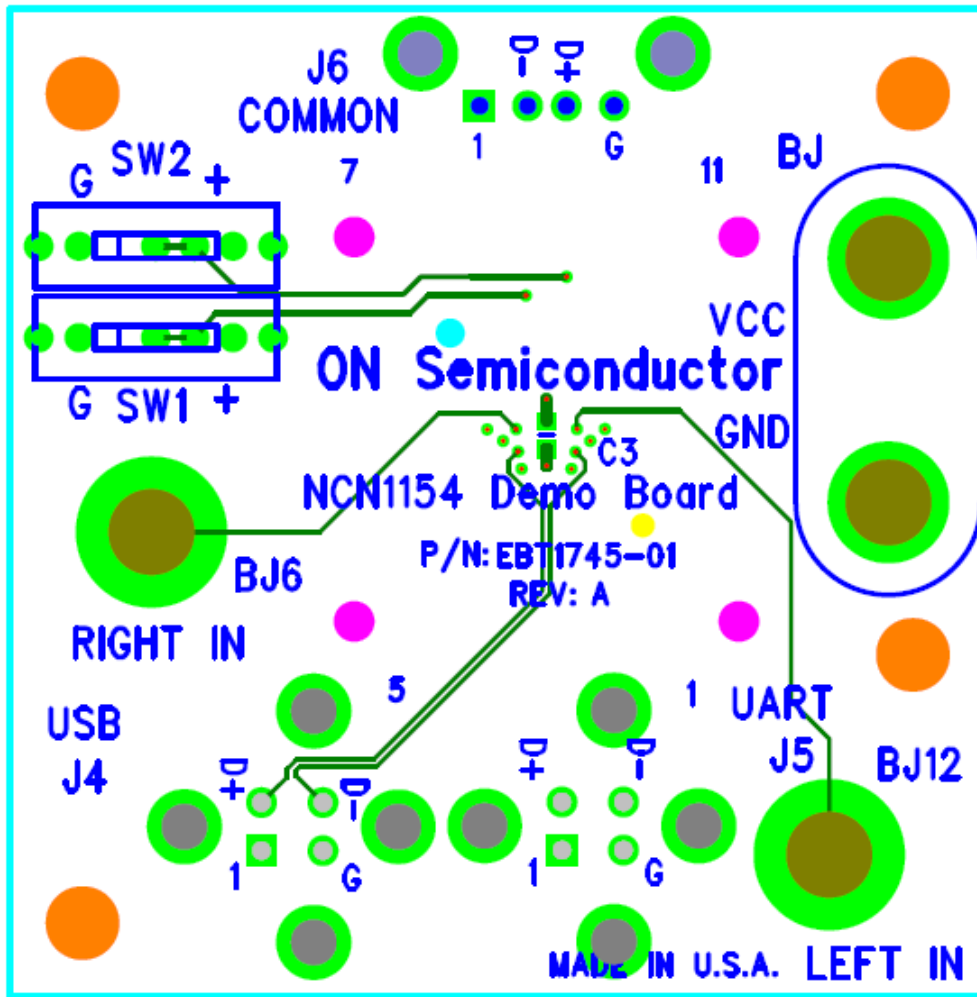

Figure 4. Bottom Layer Routing

ON Semiconductor and the ON Semiconductor logo are trademarks of Semiconductor Components Industries, LLC dba ON Semiconductor or its subsidiaries in the United States and/or other countries. ON Semiconductor owns the rights to a number of patents, trademarks, copyrights, trade secrets, and other intellectual property. A listing of ON Semiconductor's product/patent coverage may be accessed at [www.onsemi.com/site/pdf/Patent-Marking.pdf](http://www.onsemi.com/site/pdf/Patent-Marking.pdf). ON Semiconductor is an Equal Opportunity/Affirmative Action Employer. This literature is subject to all applicable copyright laws and is not for resale in any manner.

The evaluation board/kit (research and development board/kit) (hereinafter the "board") is not a finished product and is as such not available for sale to consumers. The board is only intended for research, development, demonstration and evaluation purposes and should as such only be used in laboratory/development areas by persons with an engineering/technical training and familiar with the risks associated with handling electrical/mechanical components, systems and subsystems. This person assumes full responsibility/liability for proper and safe handling. Any other use, resale or redistribution for any other purpose is strictly prohibited.

The board is delivered "AS IS" and without warranty of any kind including, but not limited to, that the board is production-worthy, that the functions contained in the board will meet your requirements, or that the operation of the board will be uninterrupted or error free. ON Semiconductor expressly disclaims all warranties, express, implied or otherwise, including without limitation, warranties of fitness for a particular purpose and non-infringement of intellectual property rights.

ON Semiconductor reserves the right to make changes without further notice to any board.

You are responsible for determining whether the board will be suitable for your intended use or application or will achieve your intended results. Prior to using or distributing any systems that have been evaluated, designed or tested using the board, you agree to test and validate your design to confirm the functionality for your application. Any technical, applications or design information or advice, quality characterization, reliability data or other services provided by ON Semiconductor shall not constitute any representation or warranty by ON Semiconductor, and no additional obligations or liabilities shall arise from ON Semiconductor having provided such information or services.

The boards are not designed, intended, or authorized for use in life support systems, or any FDA Class 3 medical devices or medical devices with a similar or equivalent classification in a foreign jurisdiction, or any devices intended for implantation in the human body. Should you purchase or use the board for any such unintended or unauthorized application, you shall indemnify and hold ON Semiconductor and its officers, employees, subsidiaries, affiliates, and distributors harmless against all claims, costs, damages, and expenses, and reasonable attorney fees arising out of, directly or indirectly, any claim of personal injury or death associated with such unintended or unauthorized use, even if such claim alleges that ON Semiconductor was negligent regarding the design or manufacture of the board.

This evaluation board/kit does not fall within the scope of the European Union directives regarding electromagnetic compatibility, restricted substances (RoHS), recycling (WEEE), FCC, CE or UL, and may not meet the technical requirements of these or other related directives.

**FCC WARNING** – This evaluation board/kit is intended for use for engineering development, demonstration, or evaluation purposes only and is not considered by ON Semiconductor to be a finished end product fit for general consumer use. It may generate, use, or radiate radio frequency energy and has not been tested for compliance with the limits of computing devices pursuant to part 15 of FCC rules, which are designed to provide reasonable protection against radio frequency interference. Operation of this equipment may cause interference with radio communications, in which case the user shall be responsible, at its expense, to take whatever measures may be required to correct this interference.

ON Semiconductor does not convey any license under its patent rights nor the rights of others.

**LIMITATIONS OF LIABILITY:** ON Semiconductor shall not be liable for any special, consequential, incidental, indirect or punitive damages, including, but not limited to the costs of requalification, delay, loss of profits or goodwill, arising out of or in connection with the board, even if ON Semiconductor is advised of the possibility of such damages. In no event shall ON Semiconductor's aggregate liability from any obligation arising out of or in connection with the board, under any theory of liability, exceed the purchase price paid for the board, if any.

For more information and documentation, please visit [www.onsemi.com](http://www.onsemi.com).

---

## PUBLICATION ORDERING INFORMATION

### LITERATURE FULFILLMENT:

Email Requests to: [orderlit@onsemi.com](mailto:orderlit@onsemi.com)

ON Semiconductor Website: [www.onsemi.com](http://www.onsemi.com)

### TECHNICAL SUPPORT

North American Technical Support:

Voice Mail: 1 800-282-9855 Toll Free USA/Canada

Phone: 011 421 33 790 2910

Europe, Middle East and Africa Technical Support:

Phone: 00421 33 790 2910

For additional information, please contact your local Sales Representative