

### Bank A

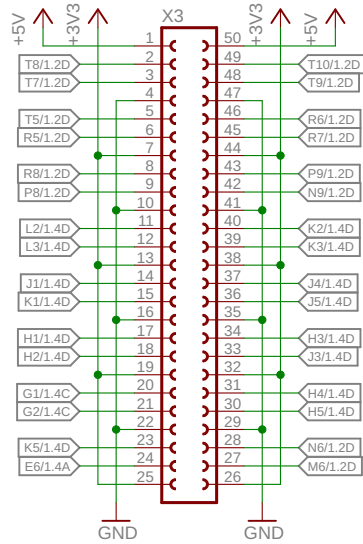

### Bank B

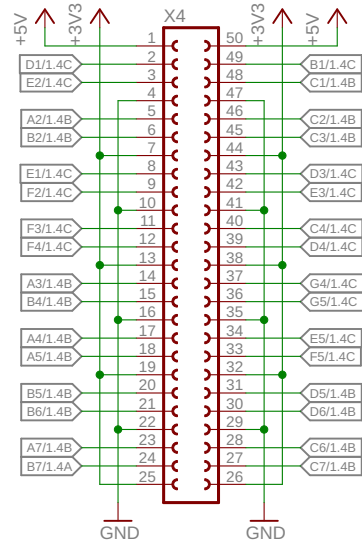

### Bank C

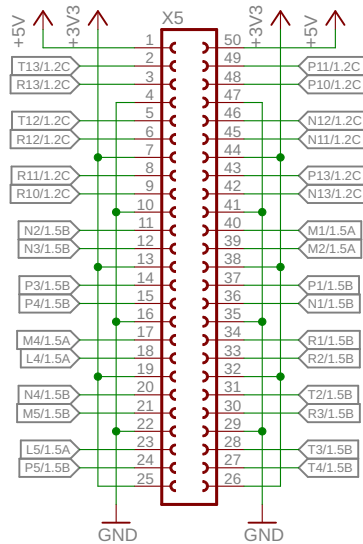

### Bank D

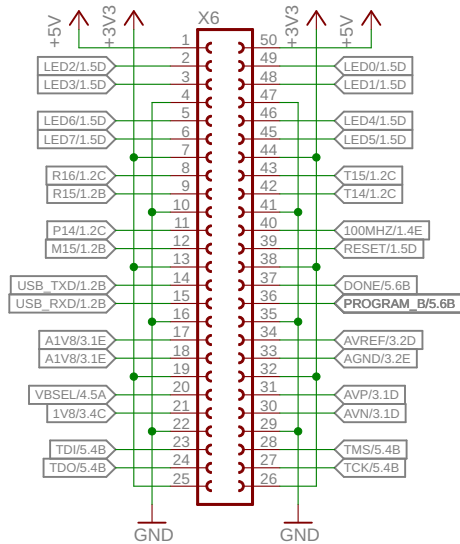

TITLE: alchitry_gold	
Document Number:	REV:
Date: 2/21/19 11:00 AM	Sheet: 2/6

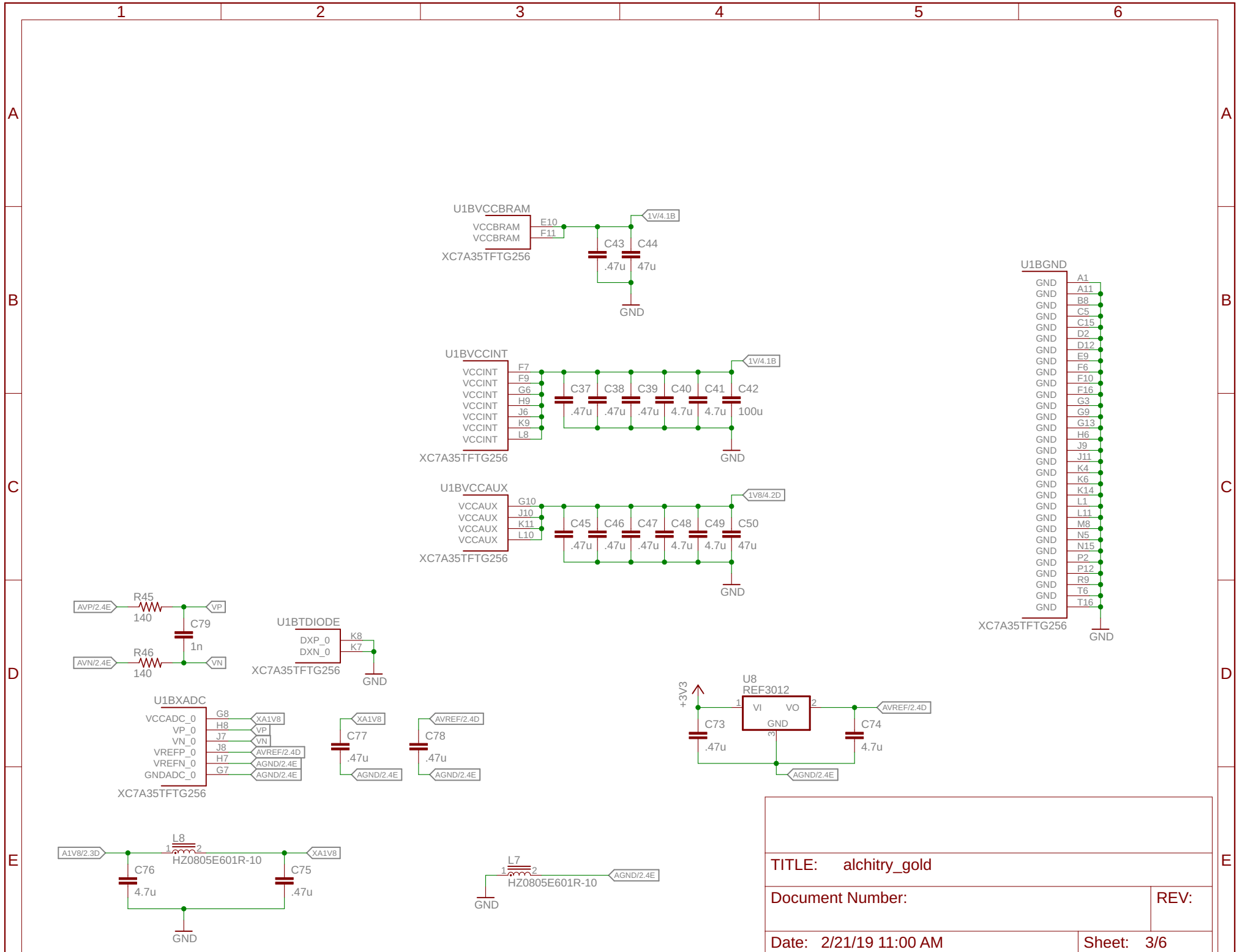

TITLE: alchitry\_gold

Document Number: REV:

Date: 2/21/19 11:00 AM

Sheet: 3/6

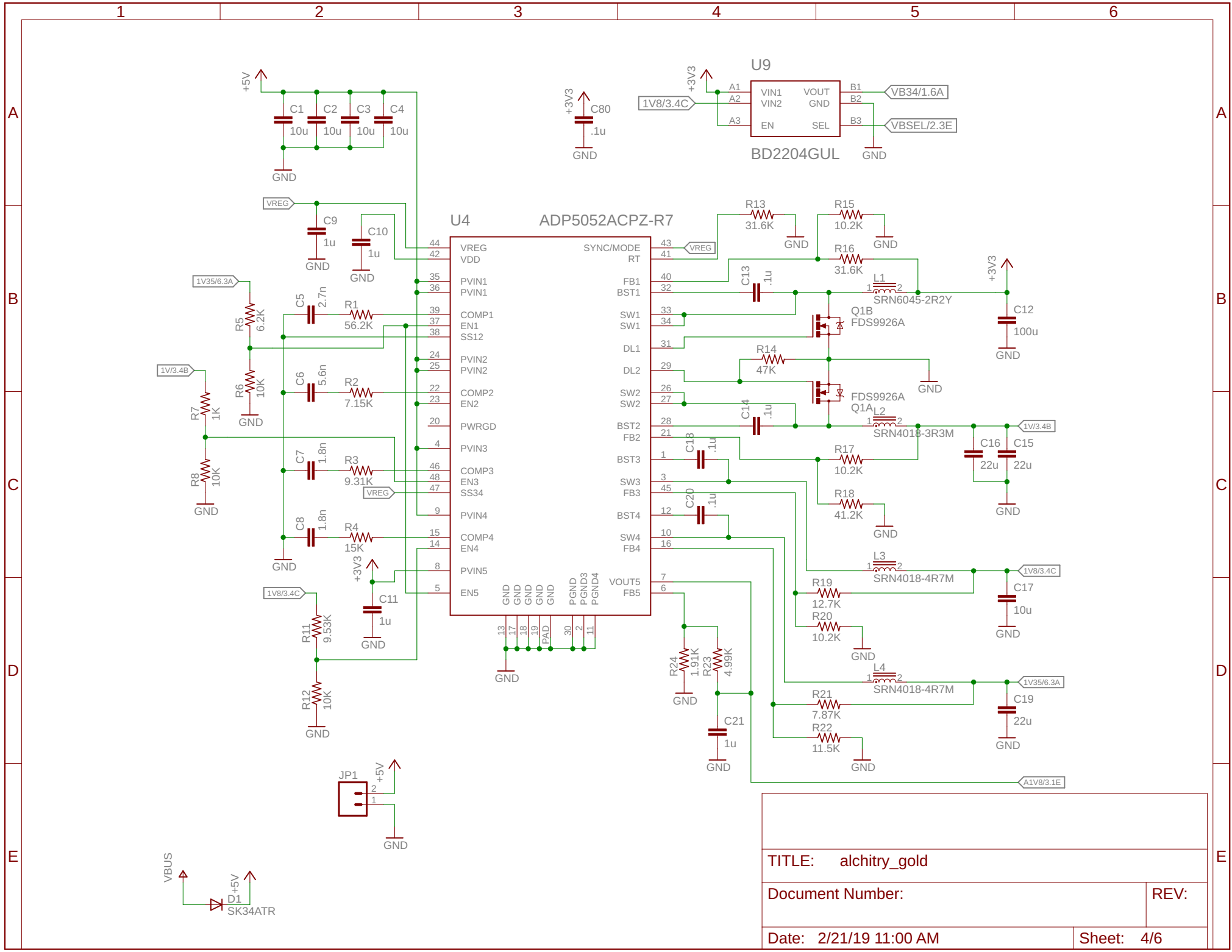

TITLE: alchitry\_gold

Document Number: \_\_\_\_\_ REV: \_\_\_\_\_

Date: 2/21/19 11:00 AM Sheet: 4/6

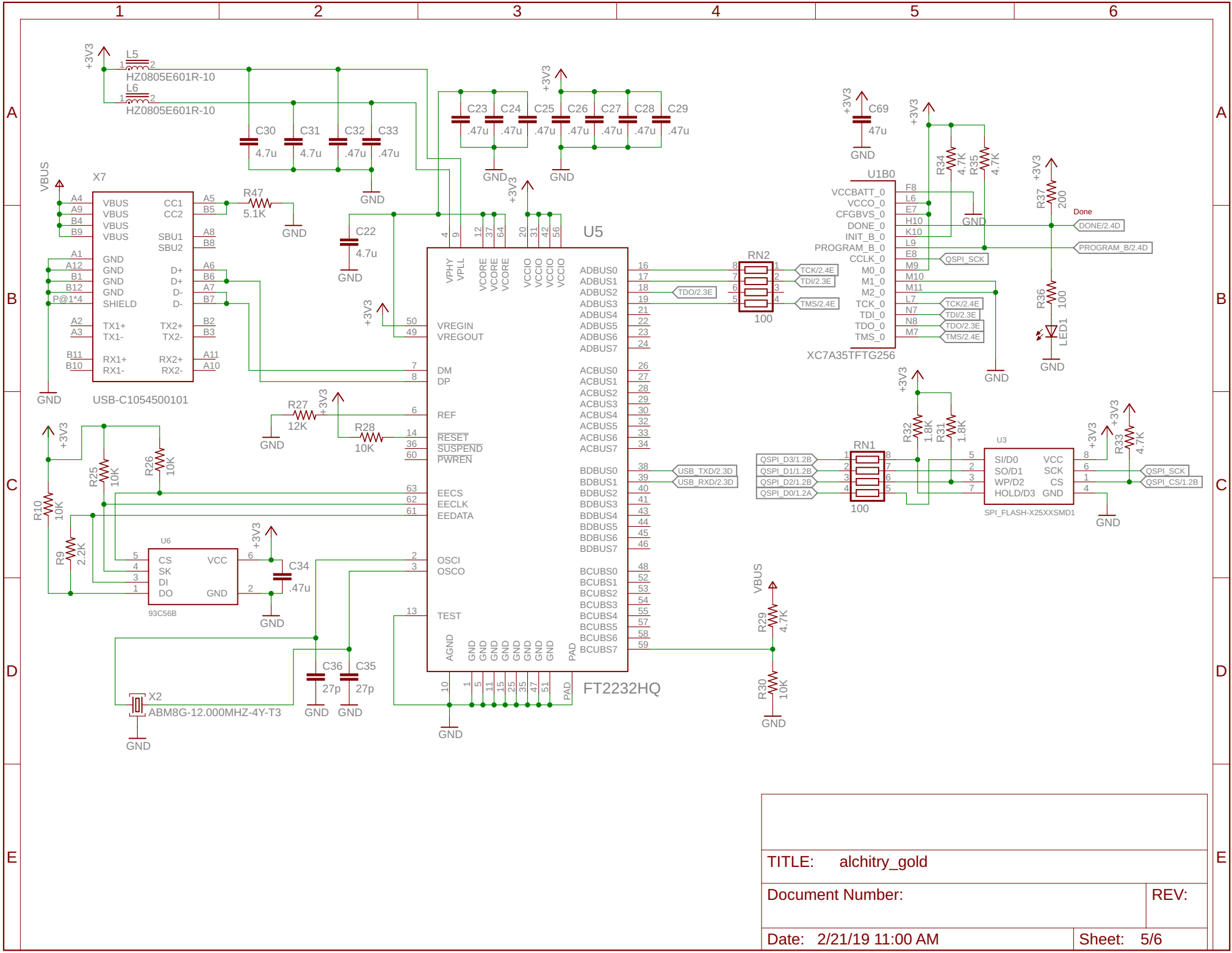

TITLE: alchitry\_gold

Document Number:

REV:

Date: 2/21/19 11:00 AM

Sheet: 5/6

