



# MCF5441X Tower Module

---

User Manual

Rev. 1.1

# Contents

<b>1</b>	<b>PURPOSE .....</b>	<b>3</b>
<b>2</b>	<b>REFERENCE DOCUMENTS .....</b>	<b>3</b>
<b>3</b>	<b>OVERVIEW .....</b>	<b>3</b>
3.1	MCF5441X OVERVIEW .....	3
3.2	TWR-MCF5441X OVERVIEW .....	5
<b>4</b>	<b>HARDWARE SPECIFICATION .....</b>	<b>6</b>
4.1	MICROCONTROLLER .....	6
4.2	CLOCKING .....	7
4.3	SYSTEM POWER .....	8
4.4	DEBUG INTERFACE .....	8
4.4.1	Standard BDM .....	8
4.4.2	OSBDM Bootloader Mode .....	10
4.4.3	OSBDM Debug Interface .....	10
4.5	RS232 HEADERS .....	10
4.6	SDRAM INTERFACE .....	11
4.7	NAND FLASH MEMORY INTERFACES .....	11
4.8	ACCELEROMETER .....	11
4.9	POTENTIOMETER .....	12
4.10	TEMPERATURE SENSOR .....	13
4.11	AUDIO HEADERS (DAC) .....	13
4.12	USER INTERFACES .....	13
4.13	RESET CONFIGURATION .....	14
4.13.1	Default Configuration (J5: 3-4 and 1-2 = ON:ON) .....	15
4.13.2	Parallel Configuration (J5: 3-4 and 1-2 = ON:OFF) .....	16
4.13.3	Serial Configuration (J5 OFF:OFF) .....	17
4.14	JUMPERS, SWITCHES .....	20
4.15	CUT/TRACE PADS .....	21

---

## 1 Purpose

---

This document provides design and usage information for the Freescale TWR\_M54418 evaluation, development and reference platform.

The TWR-MCF5441X platform provides an evaluation system for the Freescale MCF5441x ColdFire V4m embedded microprocessor family. The MCF54418 is the superset device in the family and is the processor featured on this platform. This allows evaluation and development for the entire MCF5441x family on an existing Tower system.

---

## 2 Reference Documents

---

- MCF54418 Reference Manual
- TWR-M54418 Quick Start Guide
- TWR-M54418 Schematics
- MCF54418 Data Sheet
- MMA7361L Data Sheet – Three Axis Accelerometer
- DDR2 SDRAM Specification (JESD79-2C)
- Tower Overview Presentation
- Tower Mechanical Specification
- DS18B20 Data Sheet – Temperature Sensor
- DS18B20 Application Note 120: Using an API to Control the DS1WM 1-Wire Bus Master
- TS2007 Data Sheet – Class D audio power amplifier with 6-12dB gains.
- MC9S08JM60 Reference Manual
- Cut/Trace Pads

---

## 3 Overview

---

### 3.1 MCF5441x Overview

The following is a brief summary of the functional blocks in the MCF5441x superset device.

- Version 4 ColdFire Core with MMU and EMAC
  - CPU @250 MHz
- 16 KBytes instruction cache and 16 KBytes data cache

- 64 Kbytes internal SRAM
- Support for booting from SPI-compatible flash
- Support for booting from NAND flash
- Crossbar switch technology (XBS) for concurrent access to peripherals or RAM from multiple bus masters
- 64 channel DMA controller
- DDR1/DDR2 Controller
- USB 2.0 On-the-Go controller with ULPI support
- Two smart card ports
- Two 10/100 Ethernet Controllers
- IEEE 1588-2002
- SDHC host controller
- Two CAN modules
- Cryptographic acceleration unit (CAU)
- Random number generator
- Synchronous serial interface (SSI)
- Four 32-bit timers with DMA support
- Four DMA-supported serial peripheral interface (DSPI)
- Ten UARTs
- Six I2C bus interface
- 12-bit ADC
- A multi-channel PWM
- Two DACs

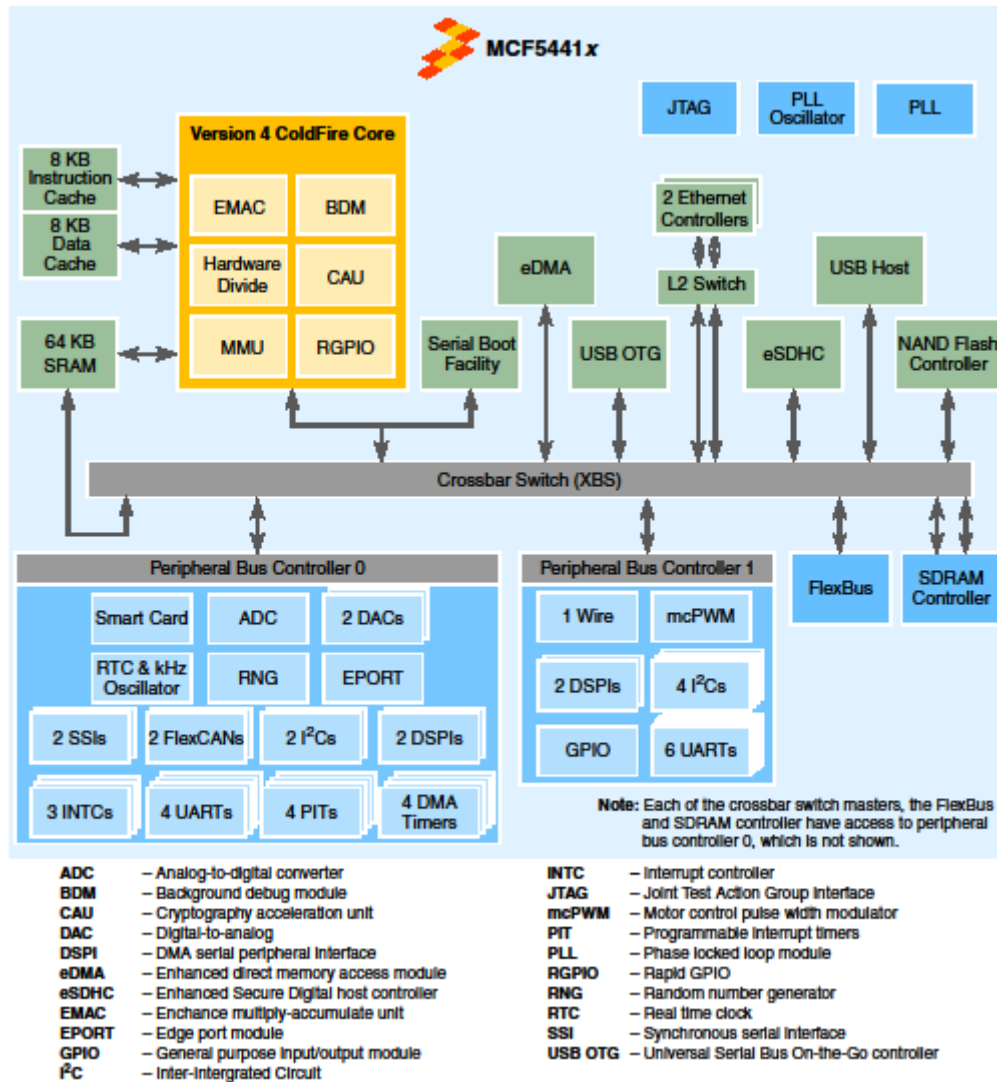

### 3.2 TWR-MCF5441X Overview

The TWR-MCF5441X provides hardware to evaluate as many of the configurations of the MCF5441x family as possible. The TWR-MCF5441X features:

- Tower compatible processor board
- MCF54418 in a 256 MAPBGA package
- DDR2 SDRAM (128 MByte)
- A NAND Flash memory device (256MByte)
- Two RS232 headers (2x5 pins)
- Standard 26-pin BDM Header

- MC9S08JM60 based Open Source BDM (OSBDM) circuit
- Standard 6-pin BKGD/MS Header
- MMA7361L three-axis accelerometer
- Wire Digital Temperature Sensor
- Four LEDs
- DIP Switches and push buttons for user input
- Potentiometer
- Audio Speaker (Header Only) uses LM4889 audio power amplifier.

## 4 Hardware Specification

This section provides specification details for the TWR-MCF5441X board.

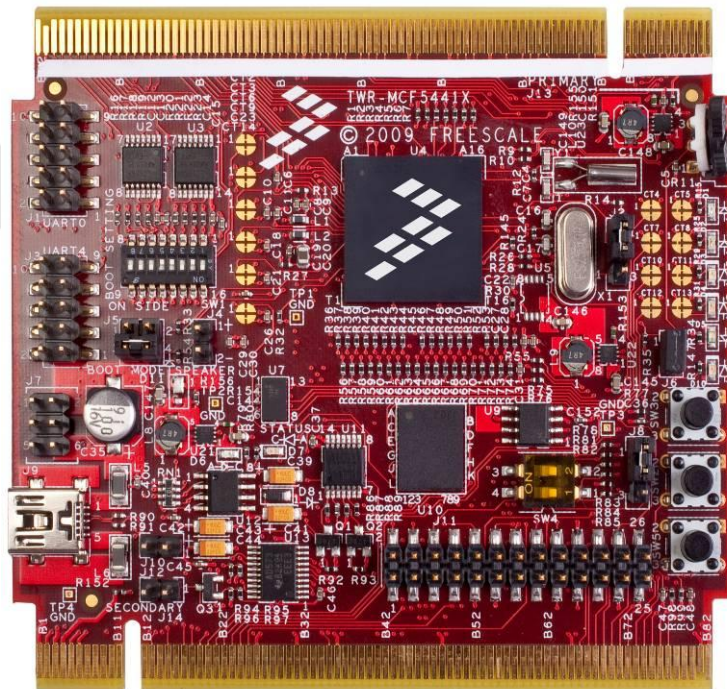

### 4.1 Microcontroller

The microcontroller on the TWR-MCF5441X will be a member of the highly-integrated 32-bit microprocessor family based on the Coldfire V4m with MMU, EMAC, and CAU units.

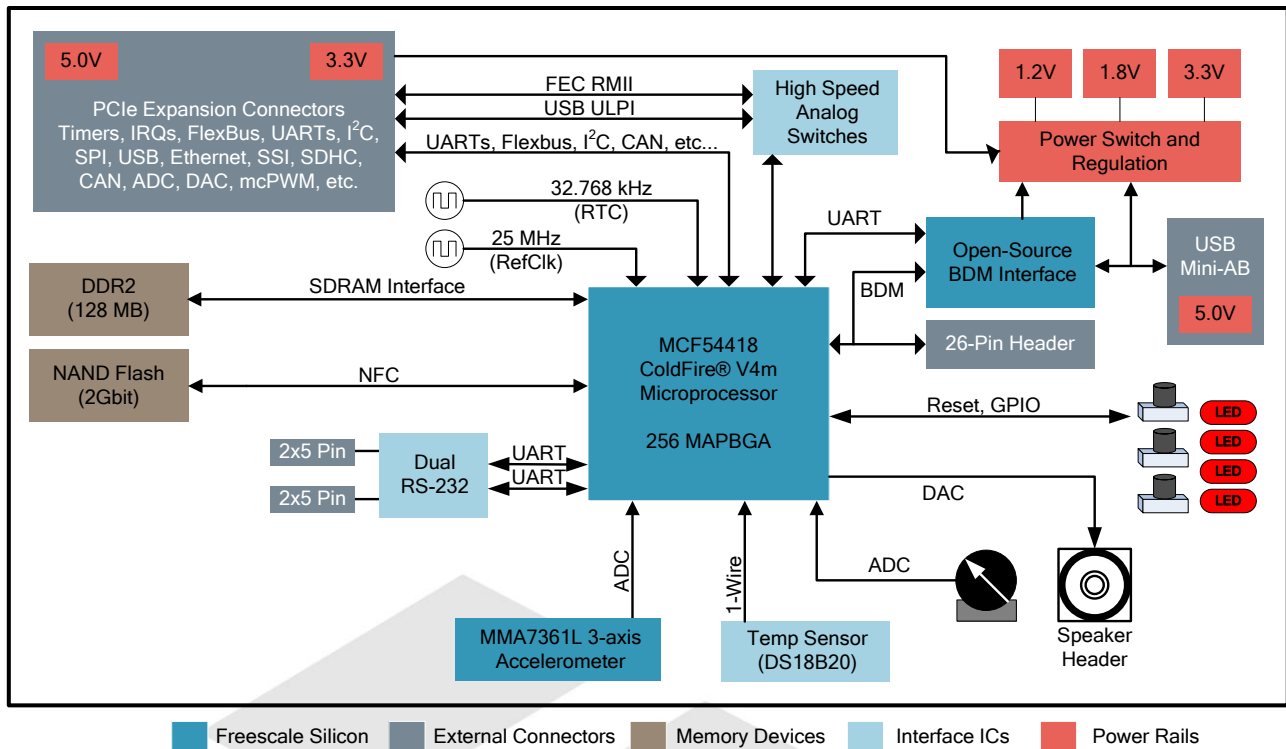

## 4.2 Clocking

The MCF54418 requires 2 clock sources in order to enable proper internal timing. A 25 MHz crystal is connected to EXTAL to generate several clocks including the CPU clock and peripherals' clock. The EXTAL can also use a 50MHz clock from the Tower Elevator (selected via jumper J2). A 32.768 kHz crystal is connected to RTC\_XTAL and RTC\_EXTAL for Real-Time Clock usage.

Clock Selection	Pin
External clock source	1-2
Onboard 25Mhz clock	2-3

**Table 1 - J2 Headers**

The MCF54418's core clock speed is default to 250 MHz on the TWR-MCF54418 platform. The DDR2 SDRAM bus speed is set at 250 MHz to generate a 500 MHz data rate. The system bus clock is set at 125MHz. All clock speeds such as CPU, SYSTEM, SDHC, USB and NAND can be programmable to desire frequency with software modification and jumpers.



To fully support the DDR2 interface a VCO of 500 MHz is required. In order to supply a VCO of 500MHz, the clock multiplier should be adjusted based on the input reference clock.

Clock Source	PLL Multiplier	SW1 Dip [7:8] settings
50MHz	10x	0:0 (On:On)
25MHz	20x	1:1 (Off:Off)

Note: VCO must be in the range from 240-500 MHz. USB frequency must be 60MHz, SDHC frequency must not be greater than 250MHz, and NAND frequency must not be greater than 80MHz.

### 4.3 System Power

The TWR-MCF5411X board is powered by +5V either from the OSBDM circuit (via the miniAB USB connector) or the Tower Elevator power connections. Power regulation circuitry is capable of providing 1.2V, 1.8V, and if needed 3.3V from either of the power source.

### 4.4 Debug Interface

TWR-MCF5441X provides two debug interfaces – a standard BDM and an Open Source BDM (OSBDM).

#### 4.4.1 Standard BDM

The primary debug port on the TWR-MCF5441X is referred to as the background debug module or BDM. The standard 26-pin BDM header (J11) is provided on the TWR-M5441X for attachment of an external BDM control interface.



J11	Function	J11	Function
1	RSTOUT_b	2	TMS/BKPT_b
3	GND	4	DSCLK
5	GND	6	TCK
7	RSTIN_b	8	TDI/DSI
9	3V3	10	TDO/DSO
11	GND	12	PST3
13	PST2	14	PST1
15	PST0	16	DDATA3
17	DDATA2	18	DDATA1
19	DDATA0	20	GND
21	NC	22	NC
23	GND	24	PSTCLK/OSBDM
25	3V3	26	NC

**Table 2 - BDM Headers**

The MCF5441x also features IEEE 1149.1 Test Access Port (JTAG) test logic that can be used for boundary-scan testability. The access pins for JTAG are multiplexed over the BDM control signals and are available on J11.

The JTAG\_EN input signal to the MCF5441x determines the debug mode: BDM or JTAG. This signal is controllable by J6 as shown below:

Debug Mode	Pin
JTAG	No shunt
BDM	Shunt on 1-2

**Table 3 - J6 Headers**

The TCLK and PSTCLK signals are the only two multiplexed signals that switch input/output state, depending on which debug mode is selected. In BDM mode, the PSTCLK is an output from the MCF5441x to the external BDM control interface. In JTAG mode, TCLK is the test clock input. The standard 26-pin BDM header defines pin 24 as PSTCLK. A common practice is to place TCLK on pin 6 of this header. J8 is available to control the routing of the multiplexed TCLK\_PSTCLK signal to the 26-pin debug header (J11) as shown below.

TCLK_PSTCLK Routing	Pin
TCK/PSTCLK on J11[pin 24]	1-2
TCK/PSTCLK on J11[pin 6]	2-3

**Table 4 - J8 Headers**

### 4.4.2 OSBDM Bootloader Mode

The MC9S08JM60 device used in the OSBDM circuit is preprogrammed with OSBDM debugger firmware and a USB Bootloader. Jumper J10 determines which application will run following a power-on reset. If Bootloader Mode is chosen (Jumper ON J10), the bootloader will be executed, allowing in-circuit reprogramming of the JM60 flash memory via USB. This enables the OSBDM firmware to be upgraded by the user when upgrades become available. For details on the USB Bootloader, refer to Application Note AN3561 on the Freescale website (<http://www.freescale.com>).

The USB Bootloader communicates with a GUI application running on a host PC. The GUI application can be found on the Freescale website; search keyword “JM60 GUI”. Refer to section 2.5 and 3.3 of AN3561 for details on installing and running the application.

**Note:**

The JM60 GUI Installer should be run before connecting the OSBDM in Bootloader Mode to a host USB port. Otherwise, the JM60 USB device will not be recognized and the proper drivers will not be loaded.

### 4.4.3 OSBDM Debug Interface

The OSBDM circuit is designed so that it can program the on-board MCF54418 device. The steps necessary to operate the OSBDM in this mode are listed here:

1. Ensure that J10 is not shunted (J10 holds JM60 in reset)
2. Connect J7 (2x3 header) from TWR-MCF54418 to target debug connector

Pin	Function	Pin	Function
1	BKDG/MS	2	5V
3	NC	4	RESET_b
5	NC	6	5V

**Table 5 - J7 JM60 BKGD Headers**

### 4.5 RS232 Headers

The MCF54418 includes ten UART modules. The TWR-M5441X provides two RS232 transceivers on UART0 and UART4. Two 2x5 pin headers are provided allowing access to the RS232 interfaces - J1 (UART0) and J3 (UART4). A 2x5 adaptor to Female DB9 serial cable must be used in order to establish serial communication.

Pi n	Function	Pi n	Function
1	No Connect	2	No Connect
3	TXD	4	CTS
5	RXD	6	RTS
7	No Connect	8	No Connect
9	GND	10	3.3V

Table 6 - J1 & J3

## 4.6 SDRAM Interface

The MCF5441x is capable of supporting 256MB DDR2-500 1.8V SDRAM at 250MHz SDRAM Clock. To reduce cost, the TWR-M54418 uses an 8-bit memory bus to interface to 128MB Micron MT47H128M8 DDR2 SDRAM.

## 4.7 NAND Flash Memory Interfaces

The TWR-M54418 uses a 16-bit 2Gbit 48 pin TSOP NAND Flash device (MT29F2G16A). The NAND Flash device may use up to 256MB (2048 blocks at 64 pages per block). The first four pages of block 0 may use for boot code with an 8-bit bus interface. The NAND signals are shared with FlexBus signals. Pin Assignments must be set correctly for access to work properly for each Mode: NAND or FlexBus. The MCF5441x is capable of booting from NAND Flash Memory device.

## 4.8 Accelerometer

An MMA7361L accelerometer is connected to three ADC inputs. There are 4 GPIO signals used to configure the MMA7361L that are optional on the TWR-MCF5441X. The MMA7361L is wired as shown here (as recommended in the MMA7361L Data Sheet):

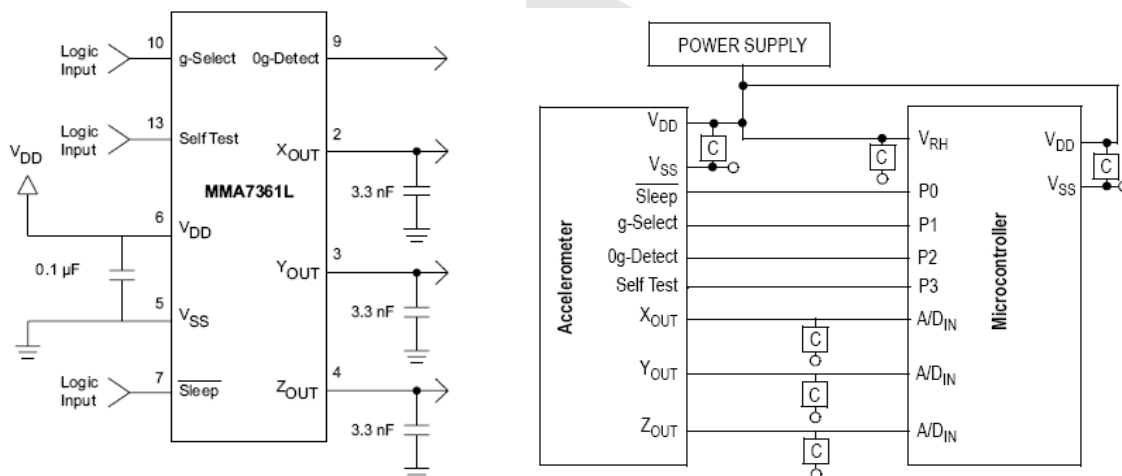

**Figure 1 - MMA7361L Connection Diagram**

By default the control signals are not connected, but can be enabled using Cut-Trace pads. By default the MMA7361L is configured to operate in normal mode with 1.5g sensitivity and no self test functionality.

The MMA7361L Accelerometer is connected as follows to the MCF54418 MPU:

Accelerometer	MCF54418	Configuration Cut-Trace Pad
X <sub>OUT</sub>	ADC_IN0	CT3
Y <sub>OUT</sub>	ADC_IN1	CT6
Z <sub>OUT</sub>	ADC_IN2	CT9
g-Select	<i>PST[0]/GPIO2</i>	CT7
nSleep	<i>PST[1]/GPIO3</i>	CT12
Self Test	<i>PST[2]/GPIO4</i>	CT4
0g-Detect	<i>PST[3]/GPIO5</i>	CT10

**Table 7 - Accelerometer Connection to MCF54418**

By default the analog signals from the accelerometer are connected to the ADC channels 0-2 of the MCF54418. If desired the connection to the accelerometer can be disconnected and the ADC channels of the MCF54418 can be connected to the edge connectors for use on a module connected to the TWR-ELEV.

To change the connection of ADC 0, 1, and 2 use the Cut-Trace pads CT3, CT6, and CT9 respectively. Using a tool with a razor blade tip sever the connection between the pads 1 and 2 of each required Cut-Trace implementation. Using a solder iron make a connection between pad 1 and pad 3.

By default the control signals for the MMA7361L accelerometer are not connected to the MCF54418. To change the connection of the control signals (G-Select, nSleep, Self Test, and 0g-Detect) use the respective Cut-Trace pads: CT7, CT12, CT4, and CT10. Using a solder iron create a connection between pads 1 and 3.

Note that it is not possible to disconnect the default signals routing (PST[3:0]) for these signals, they are used for OSBDM functionality.

For more details regarding the Cut-Trace pad options and the pad numbering refer to the Cut-Trace Pad section of this document.

## 4.9 Potentiometer

The TWR-MCF5441X includes an on-board potentiometer to allow the user to simulate an analog input.

By default voltage level from the potentiometer is connected to the ADC channel 4 of the MCF54418. If desired the connection to the potentiometer can be disconnected and the ADC channel of the MCF54418 can be connected to the edge connectors for use on a module connected to the TWR-ELEV. To change the connection of ADC 4 use the Cut-Trace pad CT14. Using a tool with a razor blade tip sever the connection between the pads 1 and 2 of the CT14. Using a solder iron make a connection between pad 1 and pad 3.

For more details regarding the Cut-Trace pad options and the pad numbering refer to the Cut-Trace Pad section of this document.

## 4.10 Temperature Sensor

TWR-M54418 uses 1-wire interface (OWIO) to interact with temperature sensor Maxim DS18B20 digital thermometer. The sensor device is powered from TWR-MCF5441X's 3.3V power circuit. The Parasite-Powered method (where the power source is from data bus) is not used in this platform.

By default the One-Wire digital temperature sensor is connected to the OWIO port on the MCF54418. Using Cut-Trace pad (CT15) the signal can be connected to the TWR-ELEV connector for connection to additional One-Wire devices. This signal can also be used to control the operating mode of a CAN transceiver on an external Tower System module. For the CAN use case, the will be configured as a GPIO and should be disconnected from any One-Wire devices. To disconnect the signal from the on-board temperature sensor cut the trace between pads 1 and 2 of CT15.

For more details regarding the Cut-Trace pad options and the pad numbering refer to the Cut-Trace Pad section of this document.

## 4.11 Audio Headers (DAC)

The TWR-MCF5441X uses National Semiconductor LM4889 Audio Power Amplifier to drive signal from DAC1\_OUT up to 1W into an 8Ω speaker.

Pin	Function
1	Output +
2	Output -

**Table 8 - J4 Headers**

## 4.12 User Interfaces

- Three push buttons:

- IRQ1 (SW3)
- IRQ2 (SW5)
- MCU reset (SW2)
- One 8-way DIP switch for controlling Parallel Reset Configuration
- One 2-way DIP Switch for additional GPIOs (Assuming BDM DDATA[3:2] are disabled).
- Four LEDs driven directly by MPU output pins.

The LEDs are concurrently connected to the LED's and the edge connector for GPIO access to external Tower System modules. If required the signals from the MCF54418 can be disconnected from either the LED's or the TWR-ELEV GPIO's. The connection to the LEDs is made between pads 1 and 2. The connection to the TWR-ELEV GPIO's is made between pads 1 and 3. Refer to the table below for details regarding which signal corresponds to which LED and TWR-ELEV GPIO.

MCF54418 Signal Name	LED	TWR-ELEV GPIO	Configuration Cut-Trace Pad
GPIO_G0	LED1 (Amber)	GPIO9 (A9)	CT3
GPIO_G1	LED2 (Yellow)	GPIO7 (A11)	CT6
GPIO_G2	LED3 (Green)	GPIO1 (B21)	CT9
GPIO_G3	LED4 (Orange/Red)	GPIO5 (B52)	CT7

For more details regarding the Cut-Trace pad options and the pad numbering refer to the Cut-Trace Pad section of this document.

### 4.13 Reset Configuration

The TWR-MCF5441X has three boot mode options:

- Boot with default configuration constants specified in the RCON register
- Boot with NAND/NOR with configuration data specified by the Flexbus FB\_AD[7:0] pins
- Boot with configuration data obtained from an external SPI memory through the serial boot facility.

The boot modes are determined by the jumper configuration of J5 at reset. Placing a jumper on pins 1-2 of J5 causes BOOTMOD[0] to be low (0). Placing a jumper on pins 3-4 of J5 causes BOOTMOD[1] to be low (0). In the table below "ON" implies that the respective jumper is shunted.

BOOTMOD[1:0]	J5 3-4 : 1-2	Description
00	ON:ON	Boot from Flexbus with default (RCON)
01	<b>ON:OFF</b>	override default via data bus (FB_AD[7:0]) – NAND/FlexBus This is the typical boot mode for the TWR-MCF5441X
10	OFF:ON	Override default and boot from serial boot facility with load configuration and optional booting from internal SRAM. If not booting from internal SRAM, serial RCON configuration will decide the boot source at address 0 either from FlexBus or NAND Flash.
11	OFF:OFF	

**Table 9 - J5 Headers**

#### 4.13.1 Default Configuration (J5: 3-4 and 1-2 = ON:ON)

If the BOOTMOD pins are 00 during reset, the MCF5441x's RCON register determines the chip configuration after reset, regardless of the states of the external data pins. The RCON register specifies the following default configuration for the MCF5441x:

- VCO clock is 50 MHz, CPU clock at 25 MHz
- System bus clock is 12.5 MHz, FlexBus clock is 6.25 MHz



### 4.13.2 Parallel Configuration (J5: 3-4 and 1-2 = ON:OFF)

If the BOOTMOD pins are 01 during reset, the MCF5441x configuration after reset is determined according to the levels driven onto the FB\_AD[7:0] pins. On the TWR-MCF5441X, the FB\_AD[7:0] pins are actively driven by two 4-bit buffers enabled when the MCF5441x RSTOUT signal is asserted. The values driven by the buffer are set by the SW1 DIP switch settings. For SW1, a value of 0 implies that the dip is switched “On”.

Override Pins in Reset	Function
<b>SW1- DIP 1</b>	<b>Boot Memory</b>
0 (Default)	NAND Flash
1	FlexBus
<b>SW1-2</b>	<b>PLL mode</b>
0	Disabled
1 (Default)	Enabled
<b>SW1-3</b>	<b>Oscillator mode</b>
0 (Default)	Crystal oscillator mode
1	Oscillator bypass mode
<b>SW1-4</b>	<b>FB_ALE select</b>
0	FB_TS_B
1 (Default)	FB_ALE
<b>SW1-[6:5]</b>	<b>BOOT Port size</b>
00	32-bit (32-bit muxed address)
01	8-bit (24-bit non-muxed address)
10 (Default)	16-bit (16-bit non-muxed address)
11	16-bit (16-bit non-muxed address)
<b>SW1-[8:7]</b>	<b>PLL Multiplier</b>
00 (Default)	Fvco = 10 x Fref
01	Fvco = 15 x Fref
10	Fvco = 16 x Fref
11	Fvco = 20 x Fref

Table 10 - SW1 8-way DIP switch

### 4.13.3 Serial Configuration (J5 OFF:OFF)

If the BOOTMOD pins are 11 during reset, then the chip configuration after reset is determined by data obtained from an external SPI memory through serial boot using the SBF\_DI, SBF\_DO, SBF\_CS, and SBF\_CLK signals. The internal configuration signals are driven to reflect the data being received from the external SPI memory to allow for module configuration. See Table below.

BYTE Address	Data Contents
0x0	{0000, BLDIV[3:0]}
0x1	BLL[7:0]
0x2	BLL[15:8]
0x3	RCON[7:0]
0x4	RCON[15:8]
0x5	RCON[23:16]
0x6	RCON[31:24]

**Table 11 - Serial Boot Facility 7-BYTE Header**

Override Serial RCON	Function
<b>SBF_RCON[31:30]</b>	<b>BOOT Port size</b>
00	32-bit (32-bit muxed address)
01	8-bit (24-bit non-muxed address)
10	16-bit (16-bit non-muxed address)
11	16-bit (16-bit non-muxed address)
<b>SBF_RCON[29]</b>	<b>Boot Memory</b>
0	NAND Flash
1	FlexBus
<b>SBF_RCON[28:27]</b>	Reserved
<b>SBF_RCON[26]</b>	<b>FB_ALE select</b>
0	FB_TS
1	FB_ALE
<b>SBF_RCON[25]</b>	<b>Oscillator mode</b>
0	Crystal oscillator mode
1	Oscillator bypass mode
<b>SBF_RCON[24]</b>	<b>PLL mode</b>
0	Disabled
1	Enabled
<b>SBF_RCON[23:22]</b>	<b>PLL Reference Divider (PLL_CR[REFDIV])</b>
00	1
01	2
<b>Override Serial RCON</b>	<b>Function</b>
10	Reserved
11	Reserved
<b>SBF_RCON[21:16]</b>	<b>PLL reference Clock Multiplier (PLL_CR[FBKDIV])</b>
<b>SBF_RCON[15]</b>	<b>FlexBus Half Clock Enable</b>
0	FlexBus Runs at Fsys/2
1	FlexBus Runs at Fsys/4
<b>SBF_RCON[14:10]</b>	<b>NFC Clock Frequency (PLL_DR[OUTDIV5])</b>
<b>SBF_RCON[9:5]</b>	<b>Internal Bus Clock Frequency (PLL_DR[OUTDIV5])</b>
<b>SBF_RCON[4:0]</b>	<b>Core Bus Clock Frequency (PLL_DR[OUTDIV5])</b>

Table 12 - Serial Boot Facility RCON Bit Definitions

The value of BLL[15:0] of serial boot header (7-byte) will determine whether the code will continue to load from SPI memory at offset 7 to internal SRAM and boot from internal SRAM. If the value of BLL[15:0] is cleared, the serial boot facility will not continue to access SPI memory after offset 6. Instead, it will depend on the SBF\_RCON bit 29 to determine whether the code will continue to load at address 0 either from FlexBus or NAND flash.

Serial RCON	
Bit	Serial RCON
31	BOOT Port size
30	
29	Boot Memory
28	Reserved
27	
26	FB_ALE select
25	Oscillator mode
24	PLL mode
23	PLL Reference Divider
22	
21	PLL Clock Multiplier
20	
19	
18	
17	
16	

Serial RCON	
Bit	Serial RCON
15	FlexBus Half Clock
14	NAND Flash Controller Clock Divider
13	
12	
11	
10	
9	
8	
7	
6	
5	Core Bus Clock Divider
4	
3	
2	
1	
0	

**Table 13 - Easy Configurable Serial RCON**

## 4.14 Jumpers, Switches

The TWR-MCF5441X implements a number of configuration jumpers, switches and headers. Refer to this section for a quick overview of each. For more details refer to the specific section related to the functionality of the specific jumper, switch, or header.

Jumpers / Header	Description
J1	UART0 Header
J2	Clock Source (25Mhz/ External) Jumper
J3	UART4 Header
J4	Audio Speaker Header
J5	Boot Mode Jumpers
J6	BDM/JTAG mode Jumper
J7	JM60 BKGD/MS Header
J8	TCK/PSTCLK_ OSBDM Jumper
J9	USB Mini B (OSBDM / PWR)
J10	JM60 IRQ (Boot Mode) Jumper
J11	26-pin BDM Header
J12	MCU Reset Jumper
J13	Primary Elevator Connection
J14	Secondary Elevator Connection

**Table 14 - Jumpers / Headers Summary**

Switches / Pushbuttons	Description
SW1	RCON Boot Settings Switch for BOOTMOD 01
SW2	MCU Reset Push Button
SW3	IRQ1 Push Button
SW4	User Input Switch (GPIOH0 / GPIOH1)
SW5	IRQ2 Puch Button

**Table 15- Switches / Push Buttons Summary**

## 4.15 Cut/Trace Pads

Cut/Trace pads have been implemented on the TWR-MCF5441X in place of configuration jumpers to ease board area constraints.

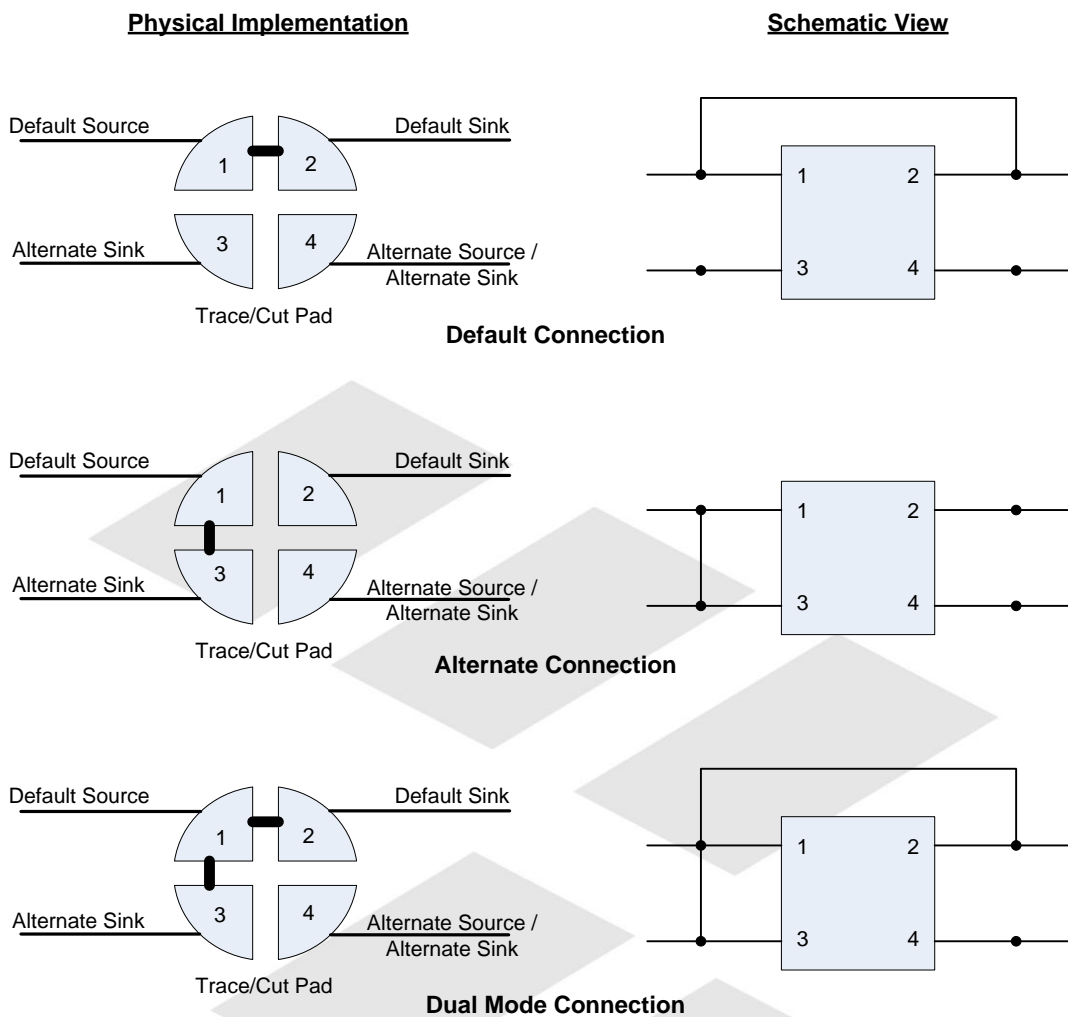

**Figure 2 - Cut/Trace Pad Details**

The TWR-MCF5441X implements the following Cut-Trace pads:

Cut-Trace Pads	Function	Primary Setting	Alternative Setting
CT1	UART5 TXD	<b>1-2: Connects TXD to TWR-ELEV</b>	1-3: Connects TXD to JM60
CT2	UART5 RXD	<b>1-2: Connects RXD to TWR-ELEV</b>	1-3: Connects RXD to JM60
CT3	ADC_0	<b>1-2: Connects Accelerometer X-axis to ADC_0</b>	1-3: Connects ADC_0 to TWR-ELEV AN0
CT4	PST2	<b>PST2 is connected to PST2 (redundant connection)</b>	1-3: Connects PST2 to Accelerometer Self_Test
CT5	GPIO PG3	<b>1-2: Connects GPIO to TWR-ELEV</b>	<b>1-3: Connect GPIO to LED 4</b>
CT6	ADC_1	<b>1-2: Connects Accelerometer Y-axis to ADC_1</b>	1-3: Connects ADC_1 to TWR-ELEV AN1
CT7	PST0	<b>PST0 is connected to PST0 (redundant connection)</b>	1-3: Connects PST0 to Accelerometer G-Select
CT8	GPIO PG2	<b>1-2: Connects GPIO to TWR-ELEV</b>	<b>1-3: Connect GPIO to LED 3</b>
CT9	ADC_2	<b>1-2: Connects Accelerometer Z-axis to ADC_2</b>	1-3: Connects ADC_2 to TWR-ELEV AN2
CT10	PST3	<b>PST3 is connected to PST3 (redundant connection)</b>	1-3: Connects PST3 to Accelerometer 0g-Detect
CT11	GPIO PG1	<b>1-2: Connects GPIO to TWR-ELEV</b>	<b>1-3: Connect GPIO to LED 2</b>
CT12	PST1	<b>PST1 is connected to PST1 (redundant connection)</b>	1-3: Connects PST1 to Accelerometer nSleep
CT13	GPIO PG0	<b>1-2: Connects GPIO to TWR-ELEV</b>	<b>1-3: Connect GPIO to LED 1</b>
CT14	ADC_4	<b>1-2: Connects Potentiometer to ADC_4</b>	1-3: Connects ADC_4 to TWR-ELEV AN4
CT15	OWIO / GPIO PD3	<b>3-4: Connects OWIO to on-board temperature sensor</b>	1-3-4: Connects OWIO to temperature sensor and allows additional One-Wire to be connected via TWR_ELEV 1-2-4: Connect s GPIO PD3 to CAN Silent Mode pin on TWR-ELEV



## Tower Elevator Connections

TWR-MCF5441X Primary Connector					
Side A					
Pin	Name	Group	Usage	Used	Jmp
A1	<b>5V</b>	<b>Power</b>	<b>5.0V Power</b>	<b>X</b>	
A2	<b>GND</b>	<b>Power</b>	<b>Ground</b>	<b>X</b>	
A3	<b>3.3V</b>	<b>Power</b>	<b>3.3V Power</b>	<b>X</b>	
A4	<b>ELE_PS_SENSE</b>	<b>Power</b>	<b>Elevator Power Sense</b>	<b>X</b>	
A5	<b>GND</b>	<b>Power</b>	<b>Ground</b>	<b>X</b>	
A6	<b>GND</b>	<b>Power</b>	<b>Ground</b>	<b>X</b>	
A7	SCL0	I2C 0	PB2/I2C0_SLC	<b>X</b>	
A8	SDA0	I2C 0	PB1/I2C0_SDA	<b>X</b>	
A9	GPIO9 / CTS1	GPIO/ UART	PG0/RGPIO	<b>X</b>	
A10	GPIO8 / SDHC_D2	GPIO/ SDHC1	PF1/SDHC_dat[2]	<b>X</b>	
A11	GPIO7 / SD_WP_DET	GPIO/ SD / SDHC1	PG4/RGPIO/SDHC_write_protect	<b>X</b>	
Mechanical Key					
A12	ETH_CRS	Ethernet			
A13	ETH_MDC	Ethernet	PI1/RMII0_MDC	<b>X</b>	
A14	ETH_MDIO	Ethernet	PI0/RMII0_MDIO	<b>X</b>	
A15	ETH_RXCLK	Ethernet			
A16	ETH_RXDV	Ethernet	PJ7/RMII0_CRS_DV	<b>X</b>	
A17	ETH_RXD3	Ethernet			
A18	ETH_RXD2	Ethernet			
A19	ETH_RXD1	Ethernet	PJ6/RMII0_RXD1	<b>X</b>	
A20	ETH_RXD0	Ethernet	PJ5/RMII0_RXD0	<b>X</b>	
A21	SSI_MCLK	SSI	PH4/SSI0_MCLK	<b>X</b>	
A22	SSI_BCLK	SSI	PH3/SSI0_BCLK	<b>X</b>	
A23	SSI_FS	SSI	PH5/SSI0_FS	<b>X</b>	
A24	SSI_RXD	SSI	PH7/SSI0_RXD	<b>X</b>	
A25	SSI_TXD	SSI	PH6/SSI0_TXD	<b>X</b>	
A26	<b>GND</b>	<b>Power</b>	<b>Ground</b>	<b>X</b>	
A27	AN3	ADC	ADC_IN3/DAC0_OUT	<b>X</b>	<b>X</b>
A28	AN2	ADC	ADC_IN2	<b>X</b>	<b>X</b>
A29	AN1	ADC	ADC_IN1	<b>X</b>	<b>X</b>
A30	AN0	ADC	ADC_IN0	<b>X</b>	<b>X</b>
A31	<b>GND</b>	<b>Power</b>	<b>Ground</b>	<b>X</b>	
A32	DAC0	DAC			
A33	TMR1	Timer	PD1/RGPIO/T2IN/T2OUT	<b>X</b>	
A34	TMR0	Timer	PD0/RGPIO/T1IN/T1OUT	<b>X</b>	
A35	GPIO6	GPIO	PB5/GPIO	<b>X</b>	
A36	<b>3.3V</b>	<b>Power</b>	<b>3.3V Power</b>	<b>X</b>	
A37	PWM3	PWM	PF1/PWM_B1	<b>X</b>	
A38	PWM2	PWM	PF2/PWM_A1	<b>X</b>	
A39	PWM1	PWM	PG6/PWM_B0	<b>X</b>	
A40	PWM0	PWM	PG5/PWM_A0	<b>X</b>	

TWR-MCF5441X Primary Connector					
Side A					
Pin	Name	Group	Usage	Used	Jmp
A41	RXD0	UART 0	PE5/RGPIO/UART6_RXD	X	X
A42	TXD0	UART 0	PE6/RGPIO/UART6_TXD	X	X
A43	RXD1	UART 1	PE1/RGPIO/UART5_RXD	X	X
A44	TXD1	UART 1	PE2/RGPIO/UART5_TXD	X	X
A45	GPIO	GPIO			
A46	GPIO	GPIO			
A47	GPIO	GPIO			
A48	GPIO	GPIO			
A49	<b>GND</b>	<b>Power</b>	<b>Ground</b>	<b>X</b>	
A50	GPIO	GPIO			
A51	GPIO	GPIO			
A52	GPIO	GPIO			
A53	GPIO	GPIO			
A54	USB0_DM	USB 0	USB0_DM	X	
A55	USB0_DP	USB 0	USB0_DP	X	
A56	USB0_ID	USB 0			
A57	USB0_VBUS	USB 0			
A58	TMR7	Timer			
A59	TMR6	Timer			
A60	TMR5	Timer			
A61	TMR4	Timer			
A62	RSTIN_b	Reset	RESET	X	
A63	RSTOUT_b	Reset	RSTOUT	X	
A64	CLKOUT0	Clock	PB7/FB_CLK	X	
A65	<b>GND</b>	<b>Power</b>	<b>Ground</b>	<b>X</b>	
A66	FB_AD14	Flexbus	FB_AD14	X	
A67	FB_AD13	Flexbus	FB_AD13	X	
A68	FB_AD12	Flexbus	FB_AD12	X	
A69	FB_AD11	Flexbus	FB_AD11	X	
A70	FB_AD10	Flexbus	FB_AD10	X	
A71	FB_AD9	Flexbus	FB_AD9	X	
A72	FB_AD8	Flexbus	FB_AD8	X	
A73	FB_AD7	Flexbus	FB_AD7	X	
A74	FB_AD6	Flexbus	FB_AD6	X	
A75	FB_AD5	Flexbus	FB_AD5	X	
A76	FB_AD4	Flexbus	FB_AD4	X	
A77	FB_AD3	Flexbus	FB_AD3	X	
A78	FB_AD2	Flexbus	FB_AD2	X	
A79	FB_AD1	Flexbus	FB_AD1	X	
A80	FB_AD0	Flexbus	FB_AD0	X	
A81	<b>GND</b>	<b>Power</b>	<b>Ground</b>	<b>X</b>	
A82	<b>3.3V</b>	<b>Power</b>	<b>3.3V Power</b>	<b>X</b>	

TWR-MCF5441X Primary Connector					
Side B					
Pin	Name	Group	Usage	Used	Jmp
B1	<b>5V</b>	<b>Power</b>	<b>5.0V Power</b>	<b>X</b>	
B2	<b>GND</b>	<b>Power</b>	<b>Ground</b>	<b>X</b>	
B3	<b>3.3V</b>	<b>Power</b>	<b>3.3V Power</b>	<b>X</b>	
B4	ELE_PS_SENSE	Power	Elevator Power Sense	<b>X</b>	
B5	<b>GND</b>	<b>Power</b>	<b>Ground</b>	<b>X</b>	
B6	<b>GND</b>	<b>Power</b>	<b>Ground</b>	<b>X</b>	
B7	SPI1_CLK / SDHC1_CLK	SPI 1 / SDHC1	PG5/SDHC_clk	<b>X</b>	
B8	SPI1_CS1 / SDHC1_CS1	SPI 1 / SDHC1			
B9	SPI1_CS0 / SDHC1_CS0	SPI 1 / SDHC1	PF2/SDHC_dat[3]	<b>X</b>	
B10	SPI1_MOSI / SDHC1_CMD	SPI 1 / SDHC1	PG6/SDHC_cmd	<b>X</b>	
B11	SPI1_MISO / SDHC1_D0	SPI 1 / SDHC1	PG7/SDHC_dat[0]	<b>X</b>	
Mechanical Key					
B12	ETH_COL	Ethernet			
B13	ETH_RXER	Ethernet	PJ4/RMII0_RXER	<b>X</b>	
B14	ETH_TXCLK	Ethernet			
B15	ETH_TXEN	Ethernet	PJ0/RMII0_TXEN	<b>X</b>	
B16	ETH_TXER	Ethernet			
B17	ETH_TXD3	Ethernet			
B18	ETH_TXD2	Ethernet			
B19	ETH_TXD1	Ethernet	PJ3/RMII0_TXD1	<b>X</b>	
B20	ETH_TXD0	Ethernet	PJ2/RMII0_TXD0	<b>X</b>	
B21	GPIO1 / RTS1	GPIO/ UART	PG2/RGPIO	<b>X</b>	
B22	GPIO2 / SDHC1_D1	GPIO/ SDHC1	PF0/SDHC_dat[1]	<b>X</b>	
B23	GPIO3	GPIO			
B24	CLKIN0	Clock	RMII_REF_CLK	<b>X</b>	<b>X</b>
B25	CLKOUT1	Clock			
B26	<b>GND</b>	<b>Power</b>	<b>Ground</b>	<b>X</b>	
B27	AN7	ADC			
B28	AN6	ADC	ADC_IN6	<b>X</b>	
B29	AN5	ADC	ADC_IN5	<b>X</b>	
B30	AN4	ADC	ADC_IN4	<b>X</b>	<b>X</b>
B31	<b>GND</b>	<b>Power</b>	<b>Ground</b>	<b>X</b>	
B32	DAC1	DAC			
B33	TMR3	Timer			
B34	TMR2	Timer			
B35	GPIO4	GPIO	PB6/GPIO	<b>X</b>	
B36	<b>3.3V</b>	<b>Power</b>	<b>3.3V Power</b>	<b>X</b>	
B37	PWM7	PWM			
B38	PWM6	PWM			
B39	PWM5	PWM	PG7/PWM_B2	<b>X</b>	
B40	PWM4	PWM	PF0/PWM_A2	<b>X</b>	
B41	CANRX	CAN	PC7/CAN1_RX	<b>X</b>	

TWR-MCF5441X Primary Connector					
Side B					
Pin	Name	Group	Usage	Used	Jmp
B42	CANTX	CAN	PB0/CAN1_TX	X	
B43	1WIRE	1-Wire			
B44	SPI0_MISO	SPI 0	PD5/DSPIO_SIN/SBF_DI	X	
B45	SPI0_MOSI	SPI 0	PD4/DSPIO_SOUT/SBF_DO	X	
B46	SPI0_CS0	SPI 0	PD7/DSPIO_PCS0/SS	X	
B47	SPI0_CS1	SPI 0	PC0/DSPIO_PCS1/BSF_CS	X	
B48	SPI0_CLK	SPI 0	PD6/DSPIO_SCK/SBF_CK	X	
B49	<b>GND</b>	<b>Power</b>	<b>Ground</b>	<b>X</b>	
B50	SCL1	I2C 1	PE0/I2C5_SCL	X	
B51	SDA1	I2C 1	PF7/I2C5_SDA	X	
B52	GPIO5	GPIO	PG3/RGPIO	X	
B53	USB_DP_PDOWN	USB	PI6	X	
B54	USB_DM_PDOWN	USB	PI7	X	
B55	IRQ_H	Interrupt	PC6/IRQ7	X	
B56	IRQ_G	Interrupt	PC6/IRQ7	X	
B57	IRQ_F	Interrupt	PC4/IRQ4	X	
B58	IRQ_E	Interrupt	PC4/IRQ4	X	
B59	IRQ_D	Interrupt	PC3/IRQ3	X	
B60	IRQ_C	Interrupt	PC3/IRQ3	X	
B61	IRQ_B	Interrupt	PC2/IRQ2	X	
B62	IRQ_A	Interrupt	PC1/IRQ1	X	
B63	FB_ALE/FB_CS1_b	Flexbus	PA7/FB_ALE	X	
B64	FB_CS0_b	Flexbus	PB3/FB_CS0	X	
B65	<b>GND</b>	<b>Power</b>	<b>Ground</b>	<b>X</b>	
B66	FB_AD15	Flexbus	FB_AD15	X	
B67	FB_AD16	Flexbus	FB_AD16/NFC_IO0	X	
B68	FB_AD17	Flexbus	FB_AD17/NFC_IO1	X	
B69	FB_AD18	Flexbus	FB_AD18/NCF_IO2	X	
B70	FB_AD19	Flexbus	FB_AD19/NFC_IO3	X	
B71	FB_R/W_b	Flexbus	PA5/FB_RW/NFC_WE	X	
B72	FB_OE_b	Flexbus	PA6/FB_OE/NFC_RE	X	
B73	FB_D7	Flexbus	FB_AD31	X	
B74	FB_D6	Flexbus	FB_AD30	X	
B75	FB_D5	Flexbus	FB_AD29	X	
B76	FB_D4	Flexbus	FB_AD28	X	
B77	FB_D3	Flexbus	FB_AD27	X	
B78	FB_D2	Flexbus	FB_AD26	X	
B79	FB_D1	Flexbus	FB_AD25	X	
B80	FB_D0	Flexbus	FB_AD24	X	
B81	<b>GND</b>	<b>Power</b>	<b>Ground</b>	<b>X</b>	
B82	<b>3.3V</b>	<b>Power</b>	<b>3.3V Power</b>	<b>X</b>	

TWR-MCF5441X Secondary Connector					
Side C					
Pin	Name	Group	Usage	Used	Jmp
C1	<b>5V</b>	<b>Power</b>	<b>5.0V Power</b>	<b>X</b>	
C2	<b>GND</b>	<b>Power</b>	<b>Ground</b>	<b>X</b>	
C3	<b>3.3V</b>	<b>Power</b>	<b>3.3V Power</b>	<b>X</b>	
C4	<b>3.3V</b>	<b>Power</b>	<b>3.3V Power</b>	<b>X</b>	
C5	<b>GND</b>	<b>Power</b>	<b>Ground</b>	<b>X</b>	
C6	<b>GND</b>	<b>Power</b>	<b>Ground</b>	<b>X</b>	
C7	SCL2	I2C 2			
C8	SDA2	I2C 2			
C9	GPIO25	GPIO			
C10	USB_STOP	ULPI	ULPI_STP	<b>X</b>	
C11	USB_CLK	ULPI	USB_CLKIN	<b>X</b>	
Mechanical Key					
C12	GPIO	GPIO			
C13	ETH_MDC	Ethernet	RMII1_MDC	<b>X</b>	
C14	ETH_MDIO	Ethernet	RMII1_MDIO	<b>X</b>	
C15	ETH_RXCLK	Ethernet			
C16	ETH_RXDV	Ethernet	RMII1_CRS_DV	<b>X</b>	
C17	GPIO	GPIO			
C18	GPIO	GPIO			
C19	ETH_RXD1	Ethernet	RMII1_RXD1	<b>X</b>	
C20	ETH_RXD0	Ethernet	RMII1_RXD0	<b>X</b>	
C21	USB_DATA0	ULPI	ULPI_DATA0	<b>X</b>	
C22	USB_DATA1	ULPI	ULPI_DATA1	<b>X</b>	
C23	USB_DATA2	ULPI	ULPI_DATA2	<b>X</b>	
C24	USB_DATA3	ULPI	ULPI_DATA3	<b>X</b>	
C25	USB_DATA4	ULPI	ULPI_DATA4	<b>X</b>	
C26	<b>GND</b>	<b>Power</b>	<b>Ground</b>	<b>X</b>	
C27	AN11	ADC			
C28	AN10	ADC			
C29	AN9	ADC			
C30	AN8	ADC			
C31	<b>GND</b>	<b>Power</b>	<b>Ground</b>	<b>X</b>	
C32	GPIO	GPIO			
C33	TMR9	Timer			
C34	TMR8	Timer			
C35	GPIO	GPIO			
C36	<b>3.3V</b>	<b>Power</b>	<b>3.3V Power</b>	<b>X</b>	
C37	PWM11	PWM			
C38	PWM10	PWM			
C39	PWM9	PWM			
C40	PWM8	PWM			
C41	RXD2	UART 2	PE4/UART2_RXD	<b>X</b>	<b>X</b>

TWR-MCF5441X Secondary Connector					
Side C					
Pin	Name	Group	Usage	Used	Jmp
C42	TXD2	UART 2	PE3/UART2_TXD	X	X
C43	RTS2	UART 2	PE5/RGPIO/UART2_RTS	X	X
C44	CTS2	UART 2	PE6/RGPIO/UART2_CTS	X	X
C45	RXD3	UART 3			
C46	TXD3	UART 3			
C47	RTS3	UART 3			
C48	CTS3	UART 3			
C49	<b>GND</b>	<b>Power</b>	<b>Ground</b>	<b>X</b>	
C50	LCD_D4 / LCD4	Display			
C51	LCD_D5 / LCD5	Display			
C52	LCD_D6 / LCD6	Display			
C53	LCD_D7 / LCD7	Display			
C54	LCD_D8 / LCD8	Display			
C55	LCD_D9 / LCD9	Display			
C56	LCD_D10 / LCD10	Display			
C57	LCD_D11 / LCD11	Display			
C58	TMR16	Timer			
C59	TMR15	Timer			
C60	TMR14	Timer			
C61	TMR13	Timer			
C62	LCD_D15 / LCD15	Display			
C63	LCD_D16 / LCD16	Display			
C64	LCD_D17 / LCD17	Display			
C65	<b>GND</b>	<b>Power</b>	<b>Ground</b>	<b>X</b>	
C66	FB_BE3 / LCD28	Flexbus / Display			
C67	FB_BE2 / LCD29	Flexbus / Display			
C68	FB_BE1 / LCD30	Flexbus / Display			
C69	FB_BE0 / LCD31	Flexbus / Display			
C70	FB_TSIZE0 / LCD32	Flexbus / Display	PA0/FB_TSIZ[0]	X	
C71	FB_TSIZE1 / LCD33	Flexbus / Display	PA1/FB_TSIZ[1]	X	
C72	FB_TS / LCD34	Flexbus / Display			
C73	FB_TBST / LCD35	Flexbus / Display			
C74	TB_TA / LCD36	Flexbus / Display			
C75	FB_CS4 / LCD37	Flexbus / Display			
C76	FB_CS3 / LCD38	Flexbus / Display			
C77	FB_CS2 / LCD39	Flexbus / Display			
C78	FB_CS1 / LCD40	Flexbus / Display			
C79	GPIO / LCD41	GPIO			
C80	LCD_D23 / LCD23	Display			
C81	<b>GND</b>	<b>Power</b>	<b>Ground</b>	<b>X</b>	
C82	<b>3.3V</b>	<b>Power</b>	<b>3.3V Power</b>		

TWR-MCF5441X Secondary Connector					
Side D					
Pin	Name	Group	Usage	Used	Jmp
D1	<b>5V</b>	<b>Power</b>	<b>5.0V Power</b>	<b>X</b>	
D2	<b>GND</b>	<b>Power</b>	<b>Ground</b>	<b>X</b>	
D3	<b>3.3V</b>	<b>Power</b>	<b>3.3V Power</b>	<b>X</b>	
D4	<b>3.3V</b>	<b>Power</b>	Elevator Power Sense	<b>X</b>	
D5	<b>GND</b>	<b>Power</b>	<b>Ground</b>	<b>X</b>	
D6	<b>GND</b>	<b>Power</b>	<b>Ground</b>	<b>X</b>	
D7	SPI2_CLK	SPI 2			
D8	SPI2_CS1	SPI 2			
D9	SPI2_CS0	SPI 2			
D10	SPI2_MOSI	SPI 2			
D11	SPI2_MISO	SPI 2			
Mechanical Key					
D12	ETH_COL	Ethernet			
D13	ETH_RXER	Ethernet	RMII1_RXER	<b>X</b>	
D14	ETH_TXCLK	Ethernet			
D15	ETH_TXEN	Ethernet	RMII1_TXEN	<b>X</b>	
D16	GPIO	GPIO			
D17	GPIO	GPIO	PH0/DIP Switches	<b>X</b>	
D18	GPIO	GPIO	PH1/DIP Switches	<b>X</b>	
D19	ETH_TXD1	Ethernet	RMII1_TXD1	<b>X</b>	
D20	ETH_TXD0	Ethernet	RMII1_TXD0	<b>X</b>	
D21	ULPI_NEXT	ULPI	PE7/RGPIO/ULPI_NXT	<b>X</b>	
D22	USB_DIR	ULPI	PD2/RGPIO/ULPI_DIR	<b>X</b>	
D23	USB_DATA5	ULPI	ULPI_DATA5	<b>X</b>	
D24	USB_DATA6	ULPI	ULPI_DATA6	<b>X</b>	
D25	USB_DATA7	ULPI	ULPI_DATA7	<b>X</b>	
D26	<b>GND</b>	<b>Power</b>	<b>Ground</b>	<b>X</b>	
D27	LCD_HSYNC / LCD24	Display			
D28	LCD_VSYNC / LCD25	Display			
D29	AN13	ADC			
D30	AN12	ADC			
D31	<b>GND</b>	<b>Power</b>	<b>Ground</b>	<b>X</b>	
D32	LCD_CLK / LCD26	Display			
D33	TMR11	Timer			
D34	TMR10	Timer			
D35	GPIO	GPIO			
D36	<b>3.3V</b>	<b>Power</b>	<b>3.3V Power</b>	<b>X</b>	
D37	PWM15	PWM			
D38	PWM14	PWM			
D39	PWM13	PWM			
D40	PWM12	PWM			
D41	CANRX1	CAN			



TWR-MCF5441X Secondary Connector					
Side D					
Pin	Name	Group	Usage	Used	Jmp
D42	CANTX1	CAN			
D43	GPIO	GPIO			
D44	LCD_OE / LCD27	Display			
D45	LCD_D0 / LCD0	Display			
D46	LCD_D1 / LCD1	Display			
D47	LCD_D2 / LCD2	Display			
D48	LCD_D3 / LCD3	Display			
D49	<b>GND</b>	<b>Power</b>	<b>Ground</b>	<b>X</b>	
D50	GPIO	GPIO			
D51	GPIO	GPIO			
D52	LCD_D12 / LCD12	Display			
D53	LCD_D13 / LCD13	Display			
D54	LCD_D14 / LCD14	Display			
D55	IRQ_P	Interrupt			
D56	IRQ_O	Interrupt			
D57	IRQ_N	Interrupt			
D58	IRQ_M	Interrupt			
D59	IRQ_L	Interrupt			
D60	IRQ_K	Interrupt			
D61	IRQ_J	Interrupt			
D62	IRQ_I	Interrupt			
D63	LCD_D18 / LCD18	Display			
D64	LCD_D19 / LCD19	Display			
D65	<b>GND</b>	<b>Power</b>	<b>Ground</b>	<b>X</b>	
D66	FB_AD20 / LCD42	Flexbus / Display	FB_AD20	<b>X</b>	
D67	FB_AD21 / LCD43	Flexbus / Display	FB_AD21	<b>X</b>	
D68	FB_AD22 / LCD44	Flexbus / Display	FB_AD22	<b>X</b>	
D69	FB_AD23 / LCD45	Flexbus / Display	FB_AD23	<b>X</b>	
D70	FB_AD24 / LCD46	Flexbus / Display	FB_AD24	<b>X</b>	
D71	FB_AD25 / LCD47	Flexbus / Display	FB_AD25	<b>X</b>	
D72	FB_AD26 / LCD48	Flexbus / Display	FB_AD26	<b>X</b>	
D73	FB_AD27 / LCD49	Flexbus / Display	FB_AD27	<b>X</b>	
D74	FB_AD28 / LCD50	Flexbus / Display	FB_AD28	<b>X</b>	
D75	FB_AD29 / LCD51	Flexbus / Display	FB_AD29	<b>X</b>	
D76	FB_AD30 / LCD52	Flexbus / Display	FB_AD30	<b>X</b>	
D77	FB_AD31 / LCD53	Flexbus / Display	FB_AD31	<b>X</b>	
D78	LCD_D20 / LCD20	Display			
D79	LCD_D21 / LCD21	Display			
D80	LCD_D22 / LCD22	Display			
D81	<b>GND</b>	<b>Power</b>	<b>Ground</b>	<b>X</b>	
D82	<b>3.3V</b>	<b>Power</b>	<b>3.3V Power</b>	<b>X</b>	



Freescale™ and the Freescale logo are trademarks of Freescale Semiconductor, Inc. All other product or service names are the property of their respective owners.

© Freescale Semiconductor, Inc. 2008. All rights reserved.