

4

3

2

1

REVISIONS			
REV.	DESCRIPTION	DATE	APPROVED
-	INITIAL RELEASE	11/21/2018	DL
1	ADDED SHEET 2 PCB DEFINITION	2/20/2019	PV
2	UPD PCB (COMMON SL AND CPW)	5/13/2019	pv
3	CHANGED PN, WAS: TMB-V4F2-1L1	1/9/2020	PV

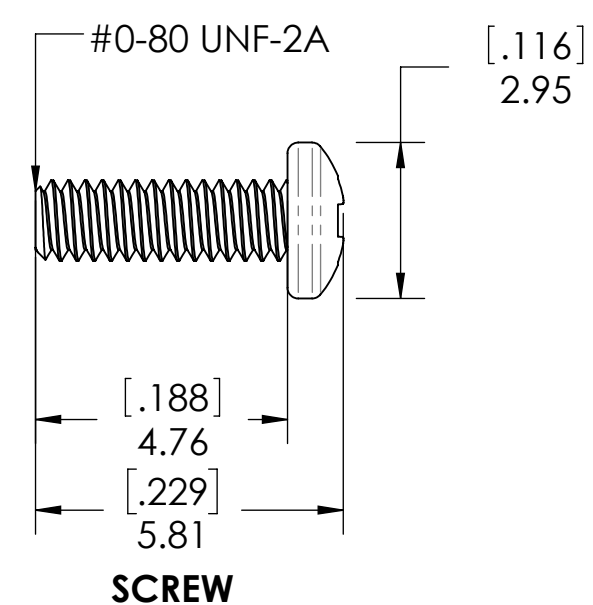
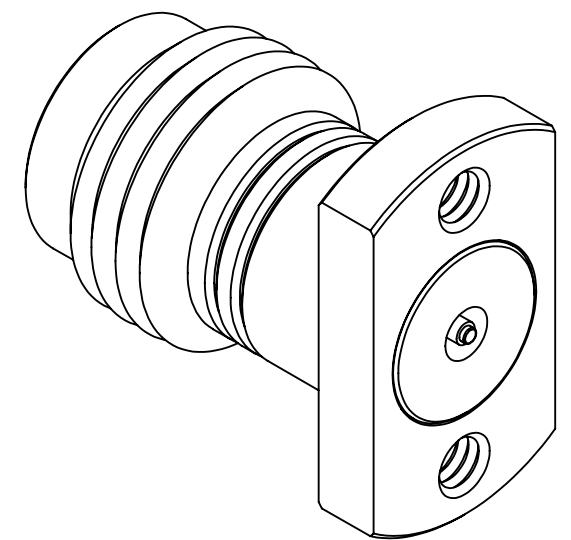
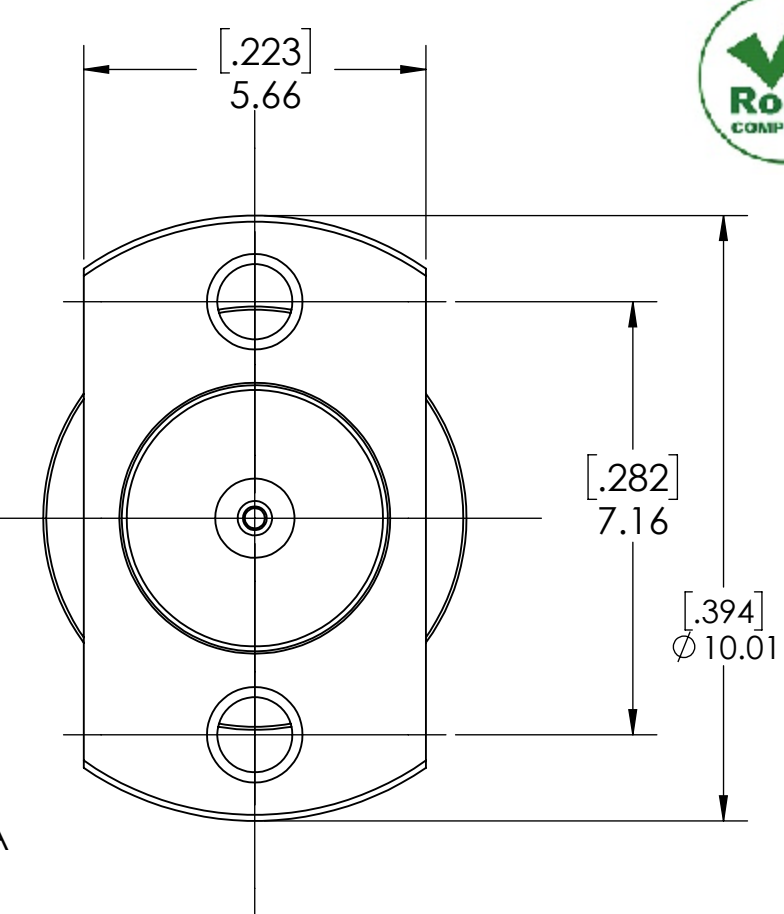
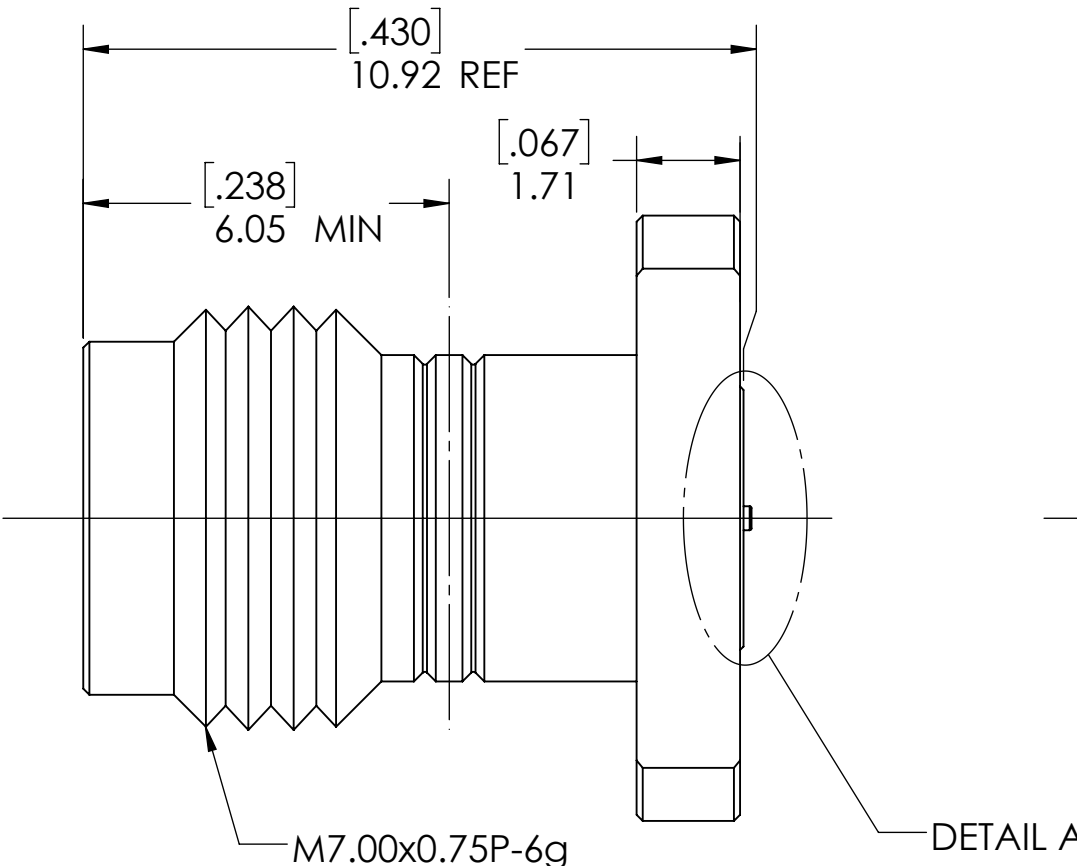
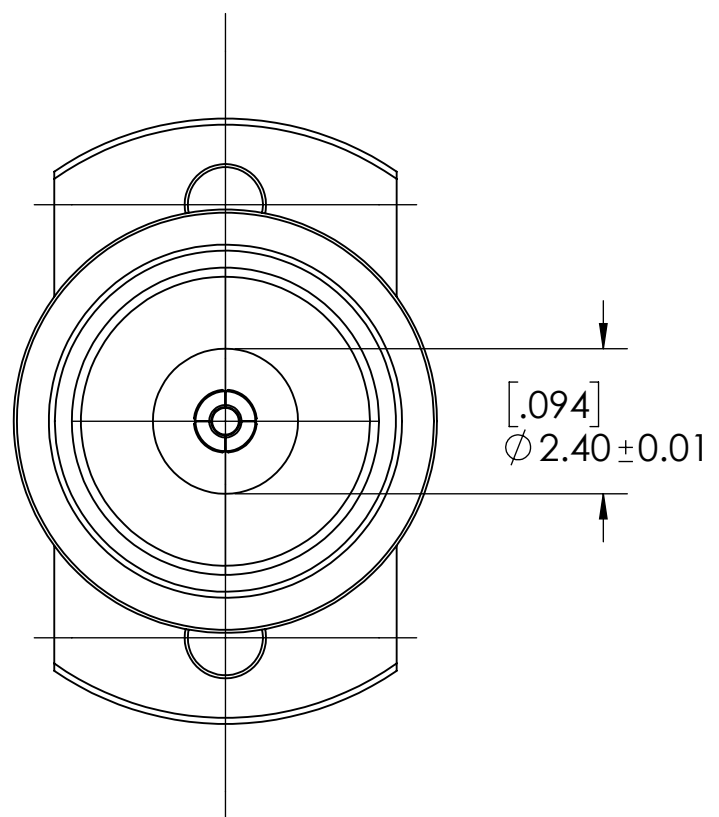

SCREW

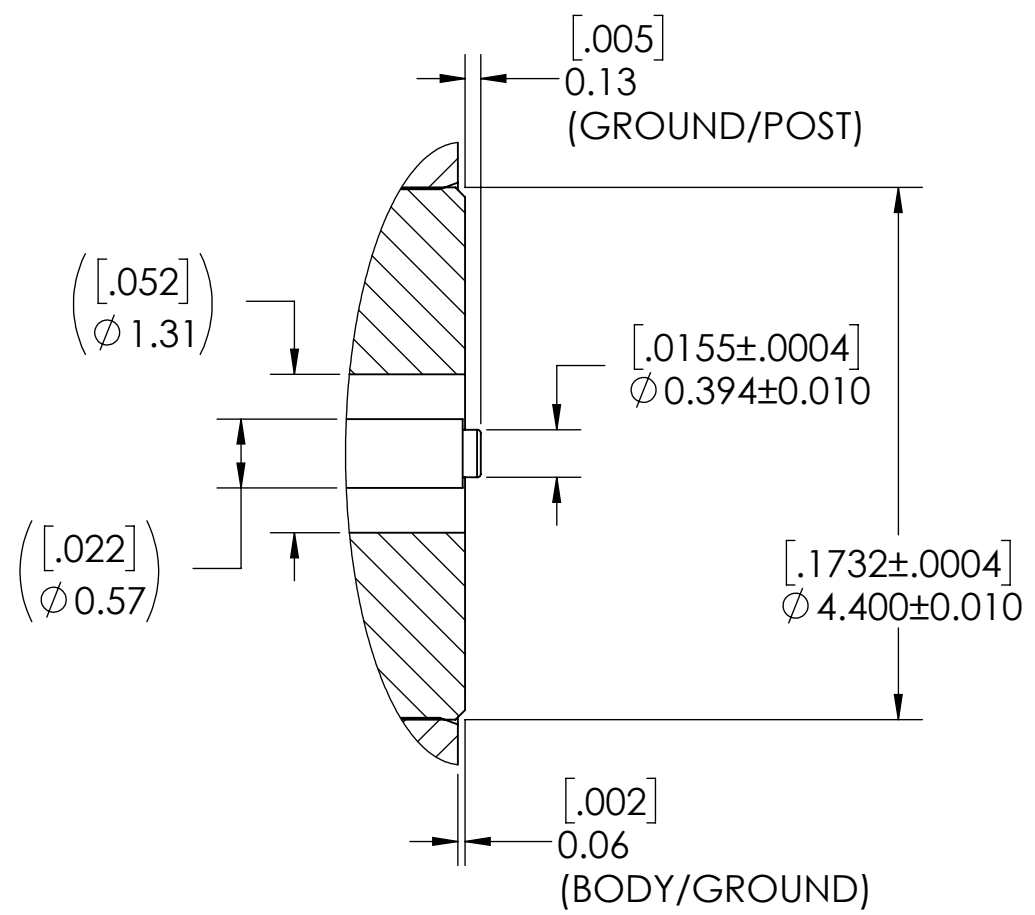

DETAIL A SCALE 16:1

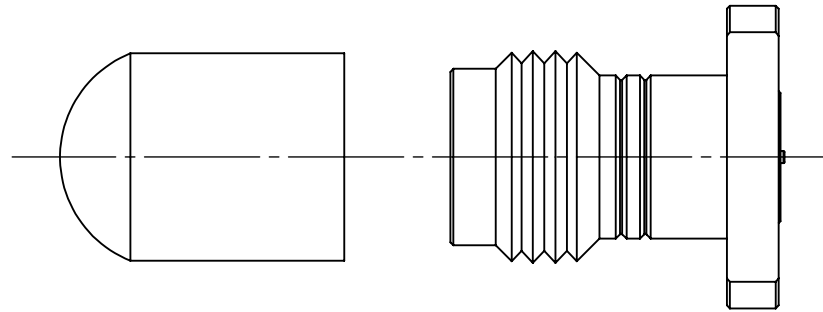
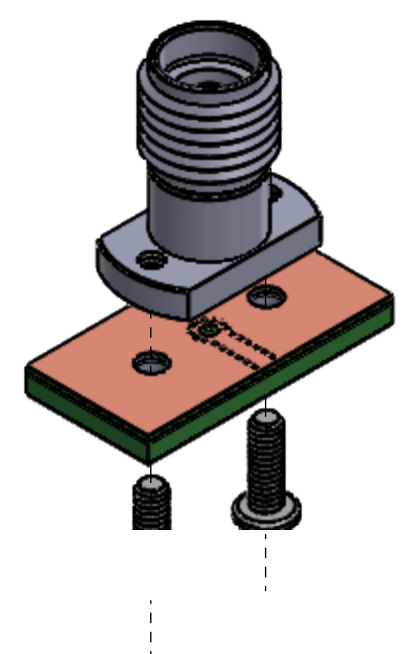

PROTECTION CAP

- NOTE(S):
1. These characteristics are typical and for reference
  2. 4909981010
  3. DYH: 60-20006-44050C
  4. See sheet 2 for PCB interface definition.

MATERIAL(S) :	ELECTRICAL(S) :	MECHANICAL(S) :	ENVIRONMENTAL(S) :
Body: Stainless Steel Center Conductor: Beryllium Copper Insulator: PCTFE, white RoHS Compliant Protective Cap: Soft PVC Color: Blue	Impedance: 50 Ohms Nominal Frequency Range: DC to 50 GHz VSWR: 1.30 max at 50 GHz Working Voltage: 500 V RMS max @ Sea Level Dielectric Withstand Voltage: 1000 V RMS max. Insulation Resistance: 5000 megaohms min. Contact Resistance: Initial: Center Contact: 3 Milliohms max Outer Contact: 2 Milliohms max Insertion Loss: <0.42 db @ 50 GHz	Mating Characteristics: Interface per MIL-STD-348 Force to Engage & Disengage: Torque: 2 inch-pounds max Longitudinal Force: NA Connector Durability: 500 Cycles min. Permeability: Less than 2.0 mu. Center Contact Retention: Axial Force: 6 pounds min. Radial Force: NA	Temperature Range: -55°C to +85°C Moisture Resistance: MIL-STD-202, Method 103, Test Condition B Corrosion: MIL-STD-202, Method 101, Test Condition B Vibration: MIL-STD-202, Method 204, Test Condition A Shock: MIL-STD-202, Method 213, Test Condition 1

FINISH(ES) :	APPLICABLE CARLISLE IT DOCUMENTS			TOLERANCES AND NOTES EXCEPT AS NOTED	APPROVAL	INITIALS	DATE	DRAWN BY	CHECKED BY	DESIGN ENG	APPR BY	TITLE	SCALE	SUB-DIRECTORY/ _OUTLINE/	SHEET 1 OF 2	REV. 3
	WORK STANDARD	PROD INSTRUC	ASSY INSTRUC													
Body: Passivated Center Conductor: Gold Plating	NA	NA	NA	THIRD ANGLE PROJECTION SCALE 8:1 DIMENSIONS ARE IN [INCHES] MM ANGLES ±2° .XX DECIMALS ±.063 .XXX DECIMALS ±.01			11/21/18	DL	KM			2.40mm FEMALE 2 HOLE FLANGE POST CONTACT	8:1			
NOTICE THIS DRAWING EMBODIES A CONFIDENTIAL PROPRIETARY DESIGN ORIGINATED BY CARLISLE INTERCONNECT TECHNOLOGIES & ALL DESIGN, MANUFACTURING, REPRODUCTION, USE & SALE RIGHTS REGARDING THE SAME ARE EXPRESSLY RESERVED. IT IS SUBMITTED UNDER A CONFIDENTIAL RELATIONSHIP FOR A SPECIFIED PURPOSE & THE RECIPIENT AGREES BY ACCEPTING THIS DRAWING NOT SUPPLY OR DISCLOSE ANY INFORMATION REGARDING IT TO ANY UNAUTHORIZED PERSON TO INCORPORATE IN OTHER PROJECTS ANY SPECIAL FEATURES PECULIAR TO THIS DESIGN. ALL PATENT RIGHTS HERETO ARE EXPRESSLY RESERVED BY CARLISLE INTERCONNECT TECHNOLOGIES, CERRITOS, CALIFORNIA 90703.													 Dongguan City, Guangdong P.R. China 523533			
													DRAWING NO. <b>TMB-V4F2-3L1</b>			

4

3

2

1

A

4

3

2

1

D

D

C

C

B

B

A

A

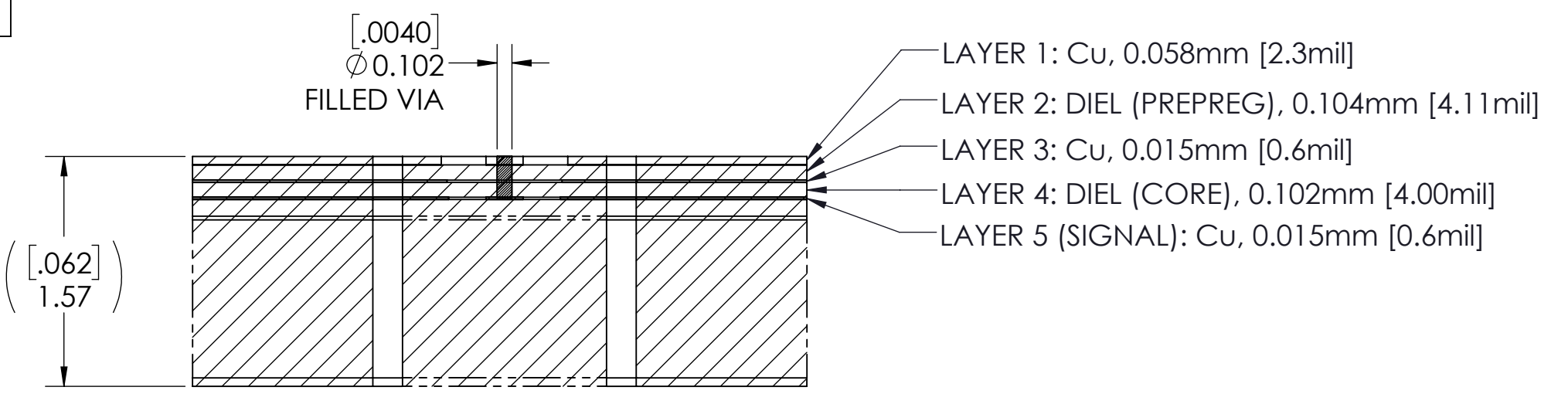
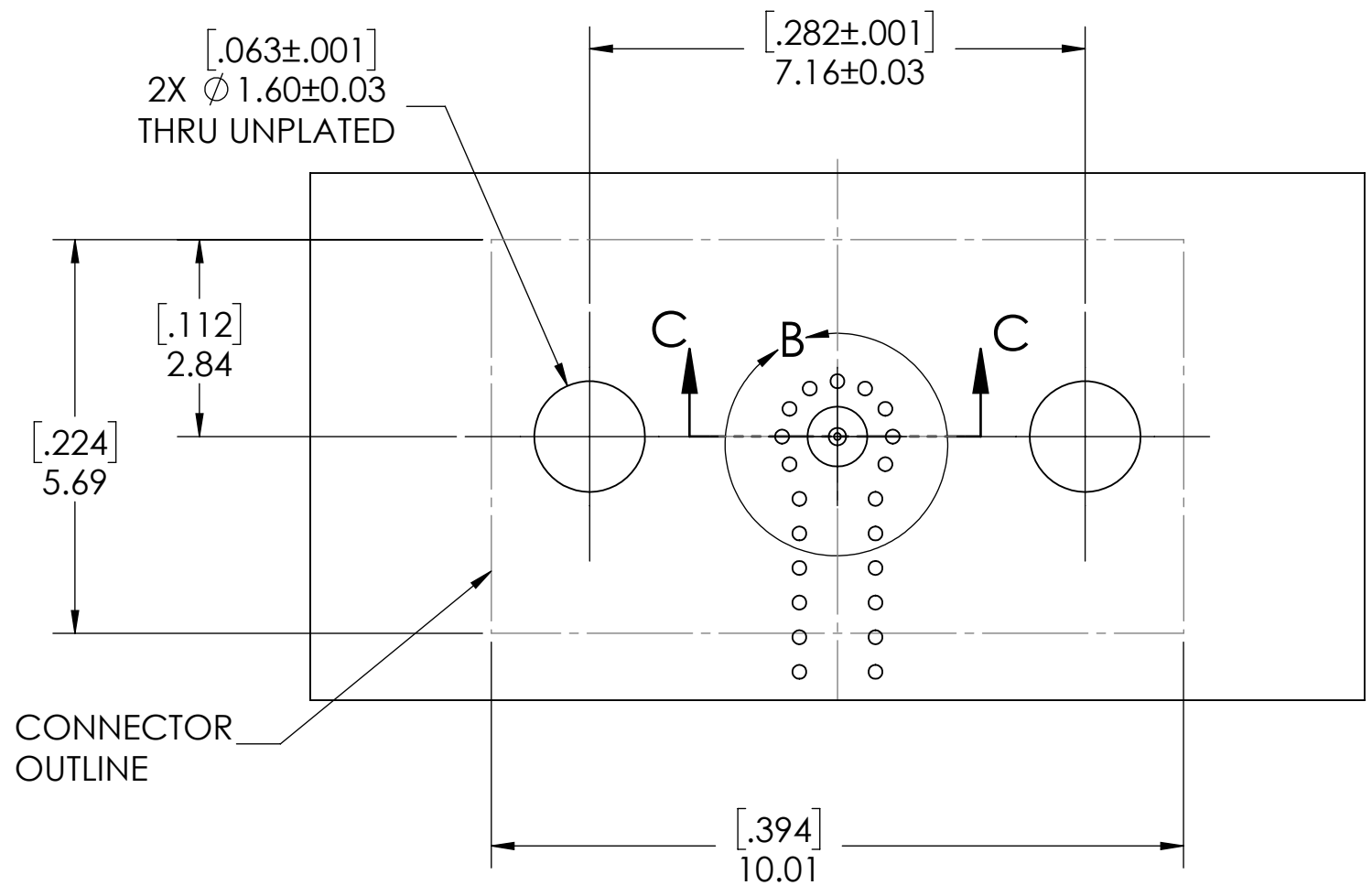
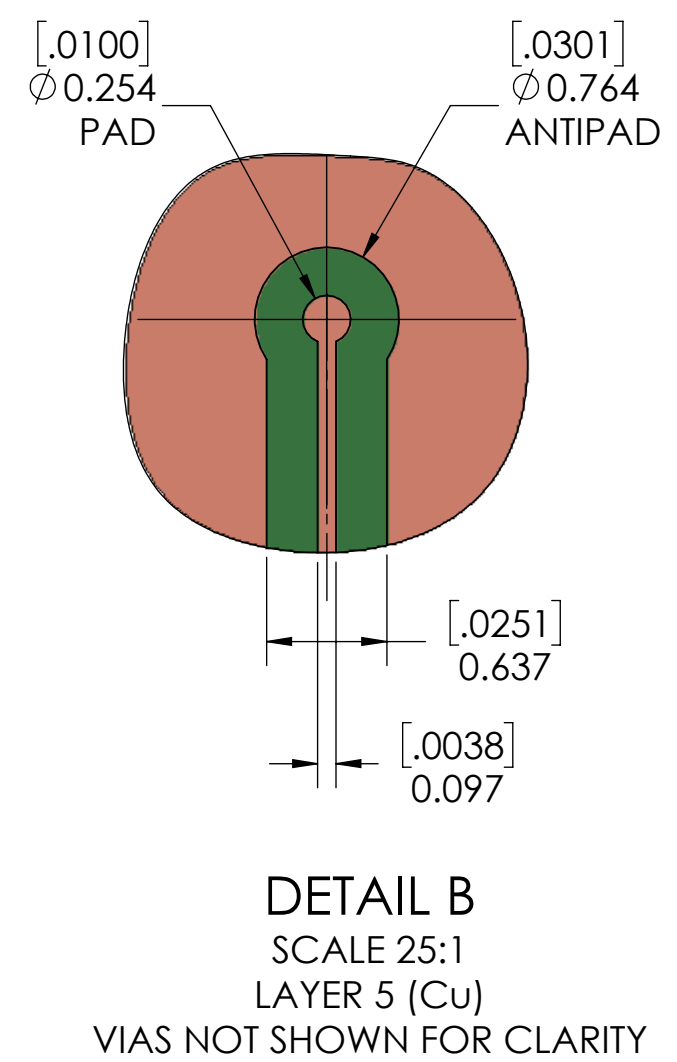
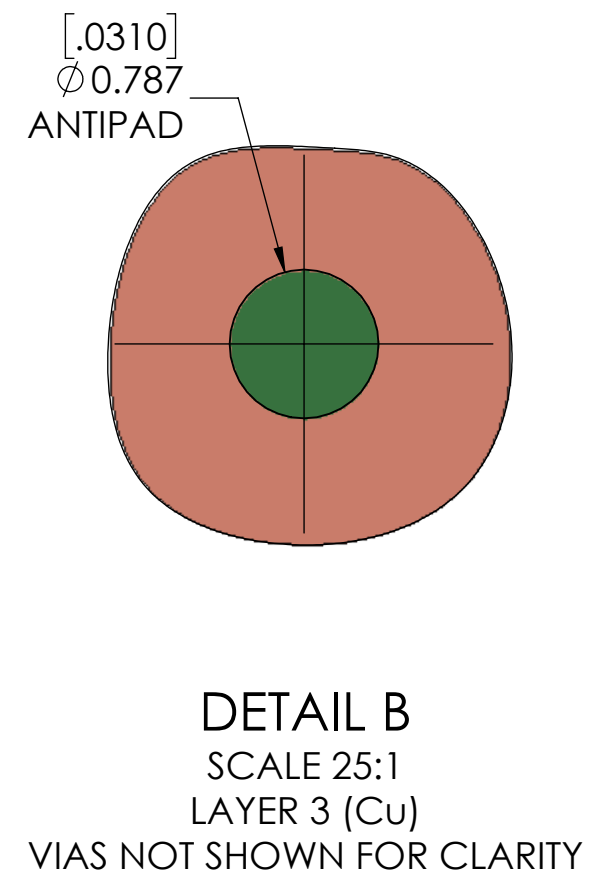
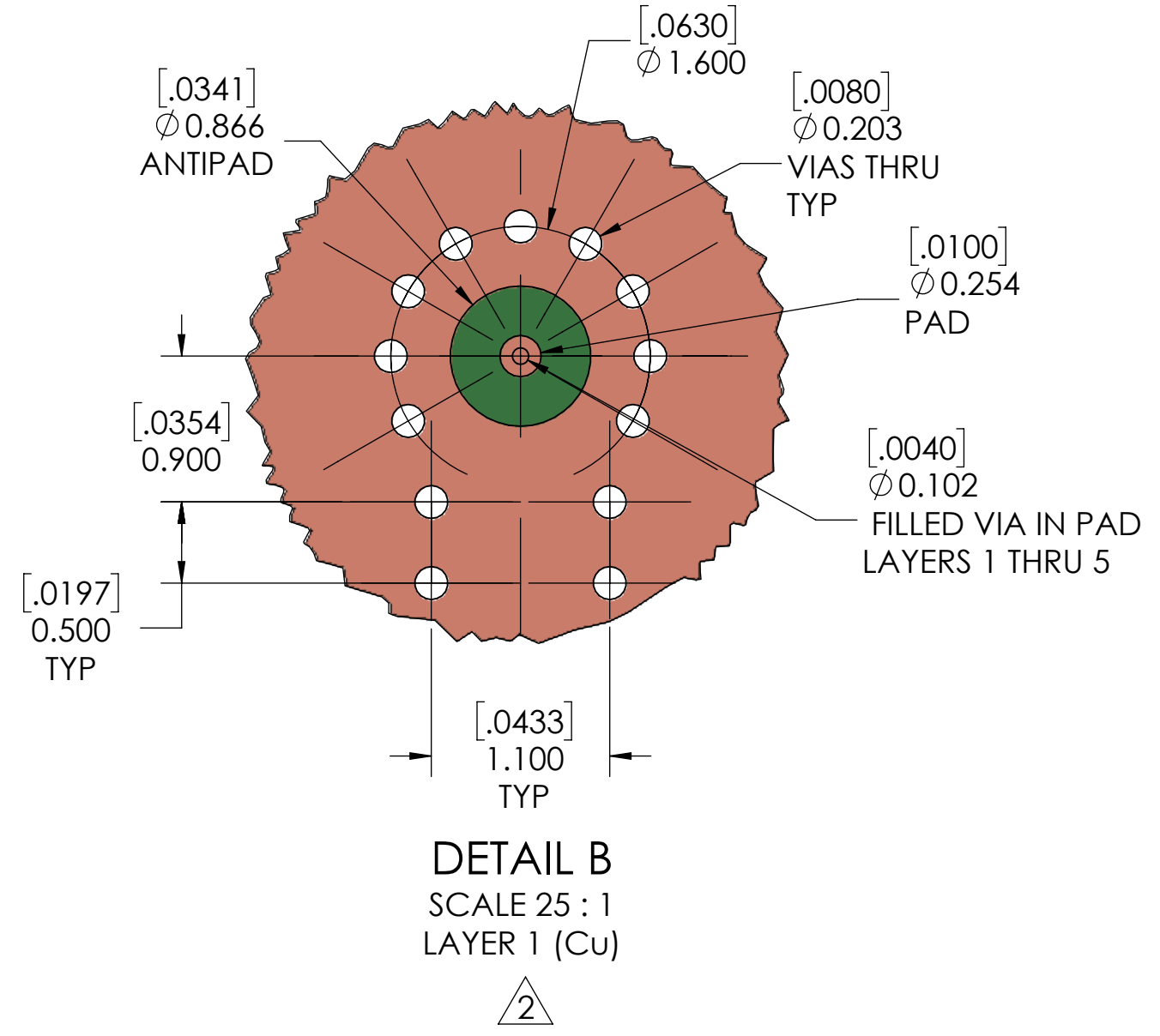

PCB LAYOUT  
(FOR REFERENCE ONLY)

**SECTION C-C**  
SCALE 25 : 1  
PCB LAYER DEFINITION

SCALE	SUB-DIRECTORY/		SHEET 2 OF 2
10:1			
SIZE	CAGE CODE	DRAWING NO.	REV.
C		<b>TMB-V4F2-3L1</b>	3

4

3

2

1