

10

9

8

7

6

5

4

3

2

1

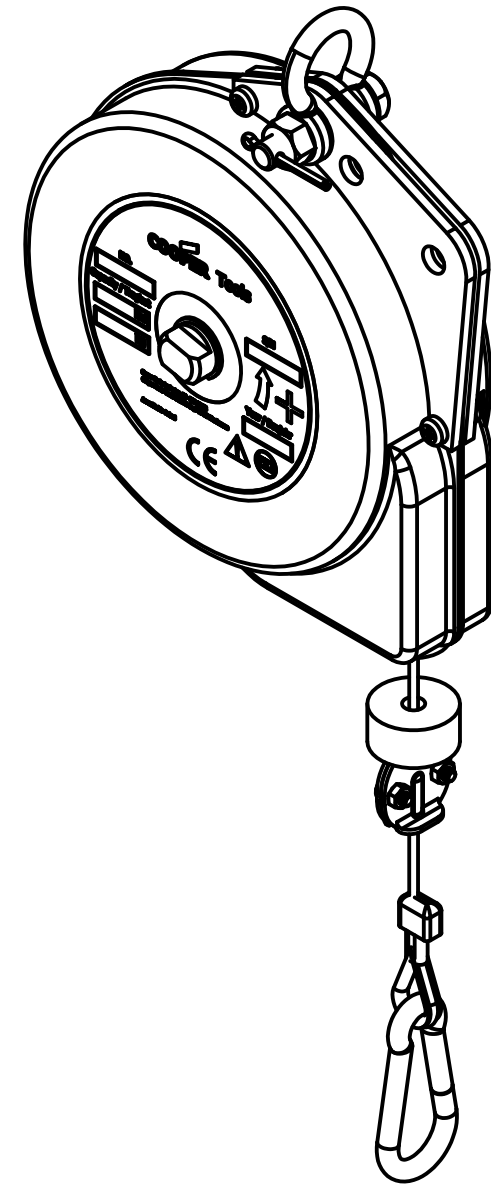
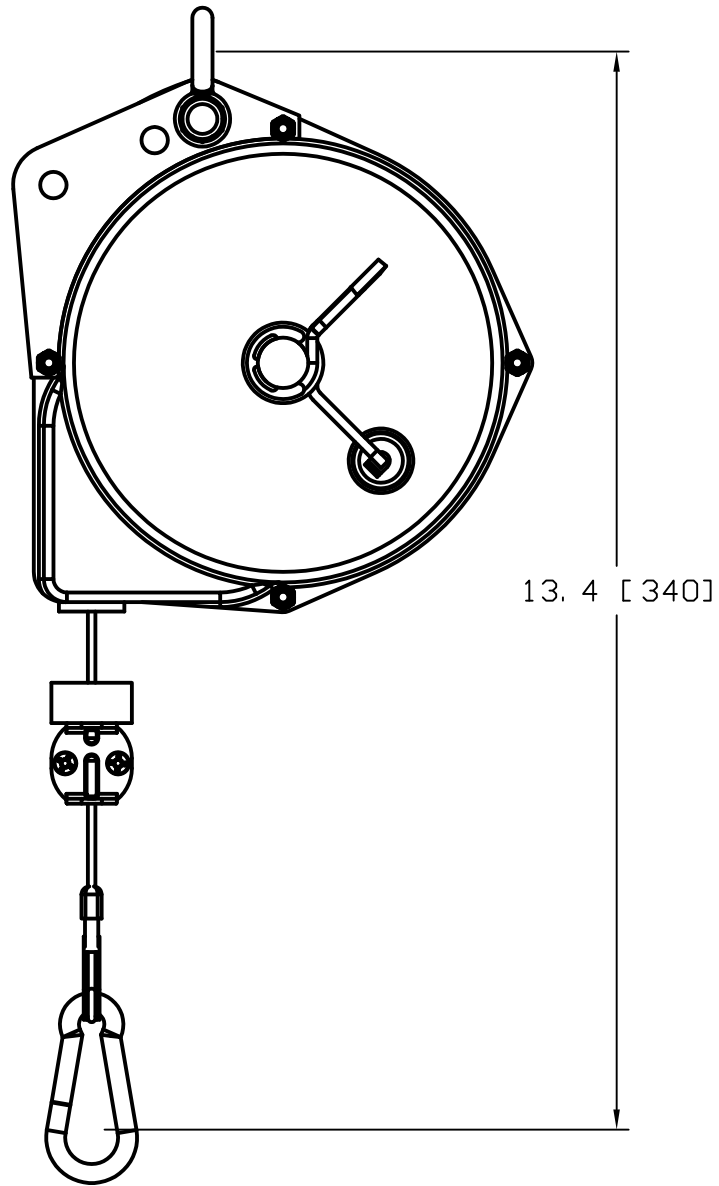
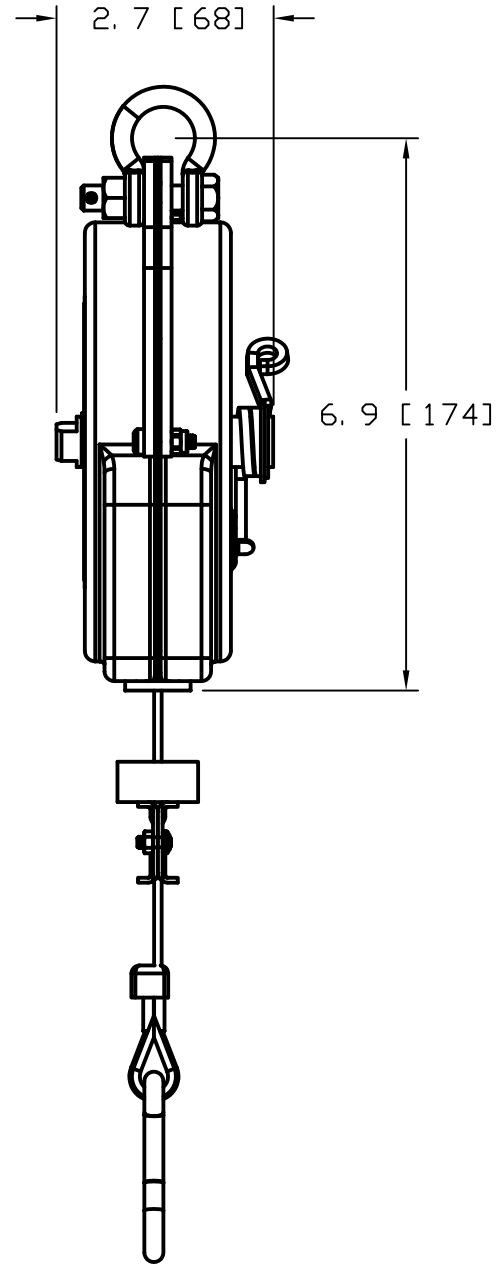
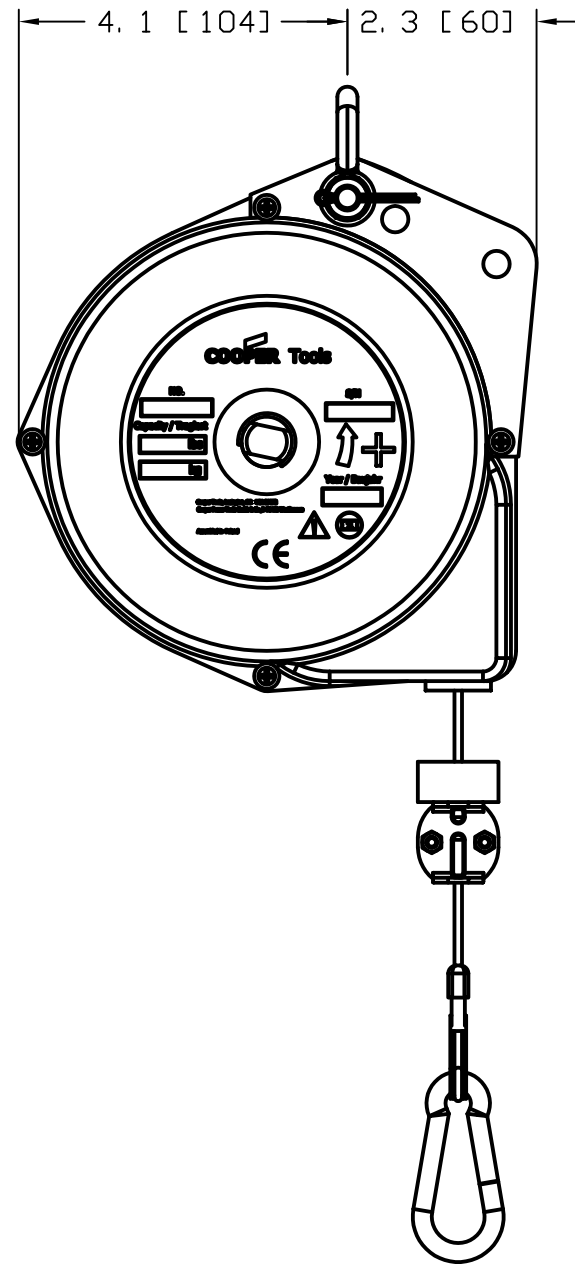

ALL DIMENSIONS ARE FOR REFERENCE ONLY.

- NOTES:
1. RETRACTORS ARE 100% INSPECTED & PRE-TENSIONED AT FACTORY.
 2. STEEL HOUSINGS HAVE A POWDER COATED FINISH TO MEET HARSH INDUSTRIAL ENVIRONMENTS. HOUSINGS COLOR IS ORANGE.
 3. ALWAYS READ INSTRUCTIONS MANUAL BEFORE USING RETRACTORS.
 4. RETRACTORS ARE NOT TO BE USED AS BALANCERS THEIR MAIN PURPOSE BEING TO RETRACT A LOAD AND NOT TO BALANCE ONE.
 5. STANDARD RETRACTORS DO NOT COME EQUIPPED WITH A SAFETY CHAIN. IF APPLICATION REQUIRES A SAFETY CHAIN ADD "SC" SUFFIX TO STANDARD PART NUMBER. EXAMPLE 5FSC.
 6. WHEN MOUNTING RETRACTOR, ALWAYS MAKE SURE THAT SAFETY PIN WHICH COMES WITH SHACKLE IS INSTALLED & SECURED.

RELEASE TO GSM EC NO: WNA2010-0563 DRWN: RHOTCA 2010/04/28 CHKD: DT APPR: DITUS 2010/05/24	QUALITY SYMBOLS ▽=0 ▽C=0	GENERAL TOLERANCES (UNLESS SPECIFIED)		DIMENSION STYLE IN/MM		SCALE NTS	DESIGN UNITS INCH	THIRD ANGLE PROJECTION		
		4 PLACES	±-	±-	DRAWN BY RHOTCA	DATE 2010/04/28	5F" SERIES RETRACTORS FOR COOPER SPECIALS			
		3 PLACES	±-	±-	CHECKED BY DT	DATE 2010/04/28				
		2 PLACES	±0.13	±.010	APPROVED BY DTITUS	DATE 2010/05/21	MATERIAL NO. SEE TABLE	DOCUMENT NO. SD-130171-002	SHEET NO. 1 OF 2	
1 PLACE	±0.25	±.020	ANGULAR ±1°		THIS DRAWING CONTAINS INFORMATION THAT IS PROPRIETARY TO MOLEX INCORPORATED AND SHOULD NOT BE USED WITHOUT WRITTEN PERMISSION					
DRAFT WHERE APPLICABLE MUST REMAIN WITHIN DIMENSIONS		SIZE B								

10

9

8

7

6

5

4

3

2

1

RETRACTOR MODEL:		ITEM #1:	ITEM #2:	CABLE ASSEMBLY USED BY EACH MODEL[ITEM 9]		RETRACTOR OUTER COLOR
MATERIAL NUMBER	ENGINEERING NUMBER	MATERIAL NUMBER	MATERIAL NUMBER	MATERIAL NUMBER	ENGINEERING NUMBER	
1301710136	BL-3B	1301790751	1301790832	1301790136	9857-1	ORANGE
1301710280	BL-3BS	1301790751	1301790832	1301794872	BG17892-1	ORANGE

LOAD CAPACITY CHART:			
RETRACTOR MODEL:		EACH RETRACTOR IS 100% TESTED UNDER THIS WEIGHT:	
MATERIAL NUMBER	ENGINEERING NUMBER	IN LBS:	IN KGS:
1301710136	BL-3B	5	2.3
1301710280	BL-3BS	5	2.3

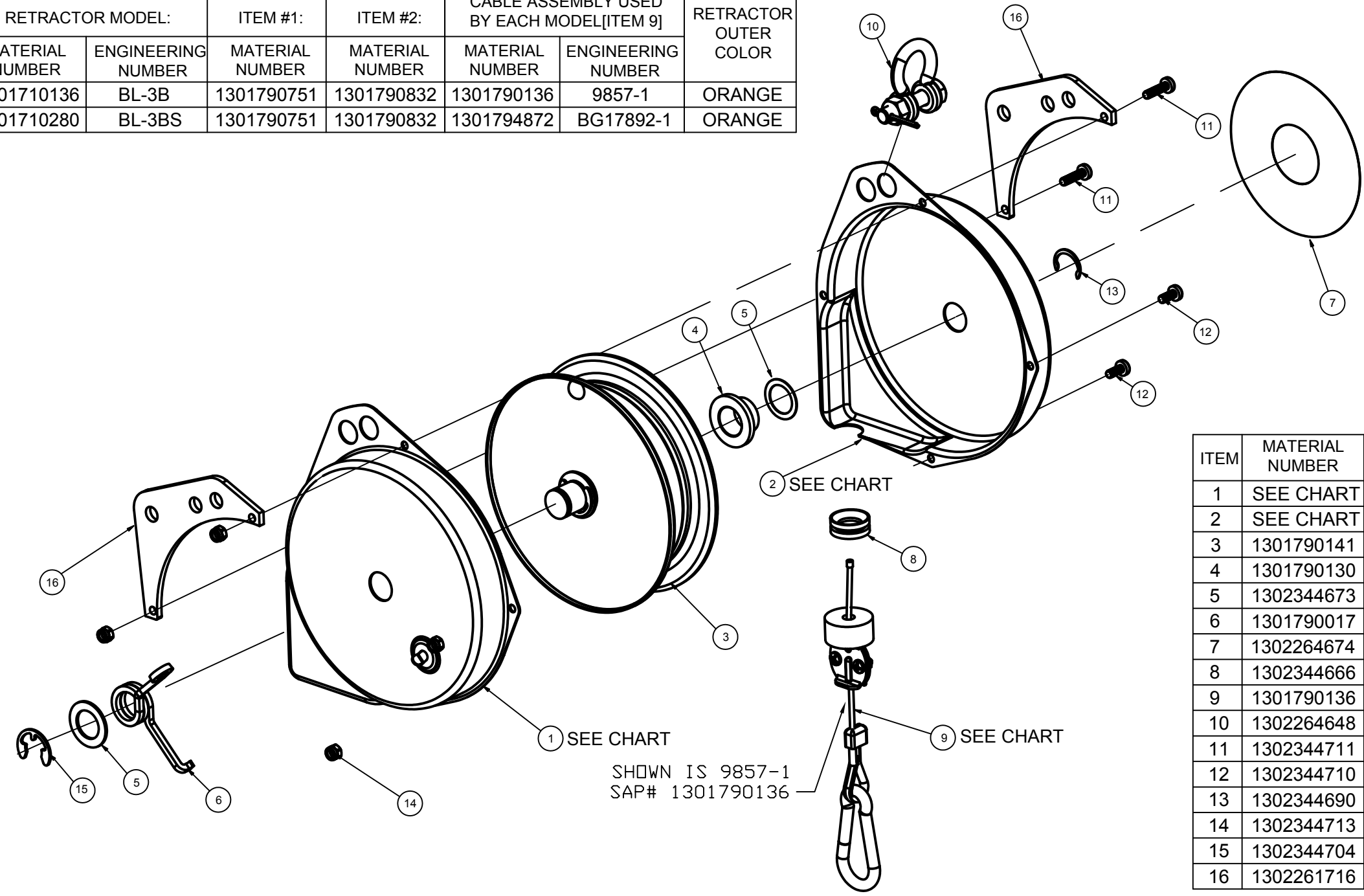

ITEM	MATERIAL NUMBER	ENGINEERING NUMBER	ITEM DESCRIPTION
1	SEE CHART	SEE CHART	5F HSNB SPRING SIDE - POWDER XXX
2	SEE CHART	SEE CHART	5F HSNB PLAIN SIDE - POWDER XXX
3	1301790141	9882	ASSY SPRING & CABLE DRUM FOR 5F
4	1301790130	9806	CABLE DRUM SPACER
5	1302344673	14099	WASHER -.63 I.D.x.88 O.D.x.02 W - BZP
6	1301790017	13611	TENSION LOCK SPRING
7	1302264674	AG16730	ROUND SILVER "COOPER" LABEL
8	1302344666	13613	GUIDE - CABLE OUTLET
9	1301790136	9857-1	ASSY CABLE FOR 5F, 2.5M LONG
10	1302264648	1240-P-10	TOP SHACKLE ASSY WITH SAFETY PIN
11	1302344711	AG14613	SCREW M4X16Lg Posi PHEAD BZP
12	1302344710	AG14612	SCREW M4X10LG Posi PHEAD BZP
13	1302344690	580-P-35	EXTERNAL CIRCLIP 0.625" SHAFT
14	1302344713	AG14615	M4 NYLOC NUT
15	1302344704	AG10310	RET RING-ANDERTON N1500-62:BZP
16	1302261716	M62730003	HANGER BRACKET - 5F BALANCER

SHOWN IS 9857-1
SAP# 1301790136

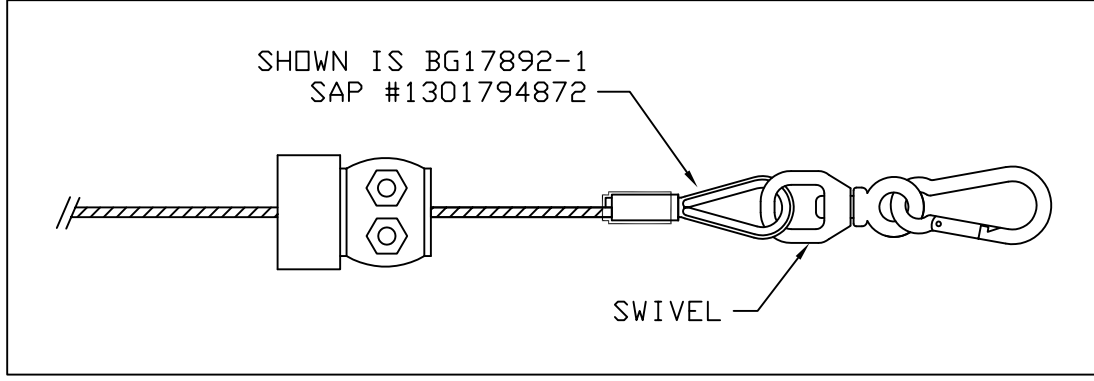

RELEASE TO GSM	EC NO: WNA2010-0563	DRWN: RHOTCA	2010/04/28	CHKD: DT	APPR: DTTITUS	2010/05/24
REV	A	DESCRIPTION				

QUALITY SYMBOLS	GENERAL TOLERANCES (UNLESS SPECIFIED)		DIMENSION STYLE	SCALE	DESIGN UNITS	THIRD ANGLE PROJECTION
	mm	INCH	IN/MM	NTS	INCH	
▽=0	4 PLACES	±	±	DRAWN BY: RHOTCA	DATE: 2010/04/28	5F" SERIES RETRACTORS FOR COOPER SPECIALS MOLEX INCORPORATED
▽C=0	3 PLACES	±	±	CHECKED BY: DT	DATE: 2010/04/28	
	2 PLACES	±0.13	±.010	APPROVED BY: DTTITUS	DATE: 2010/05/21	
	1 PLACE	±0.25	±.020	ANGULAR ±1°		MATERIAL NO. SEE TABLE DOCUMENT NO. SD-130171-002 SHEET NO. 2 OF 2
DRAFT WHERE APPLICABLE MUST REMAIN WITHIN DIMENSIONS			THIS DRAWING CONTAINS INFORMATION THAT IS PROPRIETARY TO MOLEX INCORPORATED AND SHOULD NOT BE USED WITHOUT WRITTEN PERMISSION			