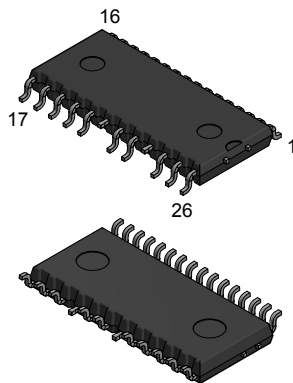

SLLIMM-nano IPM, 3-phase inverter, 2 A, 1.7  $\Omega$  max., 500 V MOSFET

NSDIP-26L

## Features

- IPM 2 A, 500 V,  $R_{DS(on)} = 1.7 \Omega$ , 3-phase MOSFET inverter bridge including control ICs for gate driving
- Optimized for low electromagnetic interference
- 3.3 V, 5 V, 15 V CMOS/TTL input comparators with hysteresis and pull-down/pull-up resistors
- Undervoltage lockout
- Internal bootstrap diode
- Interlocking function
- Shutdown function
- Comparator for fault protection against overcurrent
- Op-amp for advanced current sensing
- Optimized pinout for easy board layout
- NTC for temperature control (UL 1434 CA 2 and 4)
- Moisture sensitivity level (MSL) 3 for SMD package

## Applications

- 3-phase inverters for motor drives
- Roller shutters, dishwashers, refrigerator fans, air-conditioning fans, draining and recirculation pumps



## Description

This SLLIMM (small low-loss intelligent molded module) nano provides a compact, high-performance AC motor drive in a simple, rugged design. It is composed of six MOSFETs and three half-bridge HVICs for gate driving, providing low electromagnetic interference (EMI) characteristics with optimized switching speed. The package is optimized for thermal performance and compactness in built-in motor applications, or other low power applications where assembly space is limited. This IPM includes an operational amplifier, completely uncommitted, and a comparator that can be used to design a fast and efficient protection circuit. SLLIMM is a trademark of STMicroelectronics.

## Product status

STIPNS2M50T-H

## Device summary

<b>Order code</b>	STIPNS2M50T-H
<b>Marking</b>	IPNS2M50T-H
<b>Package</b>	NSDIP-26L
<b>Packing</b>	Tape and reel

# 1 Internal schematic diagram and pin configuration

Figure 1. Internal schematic diagram

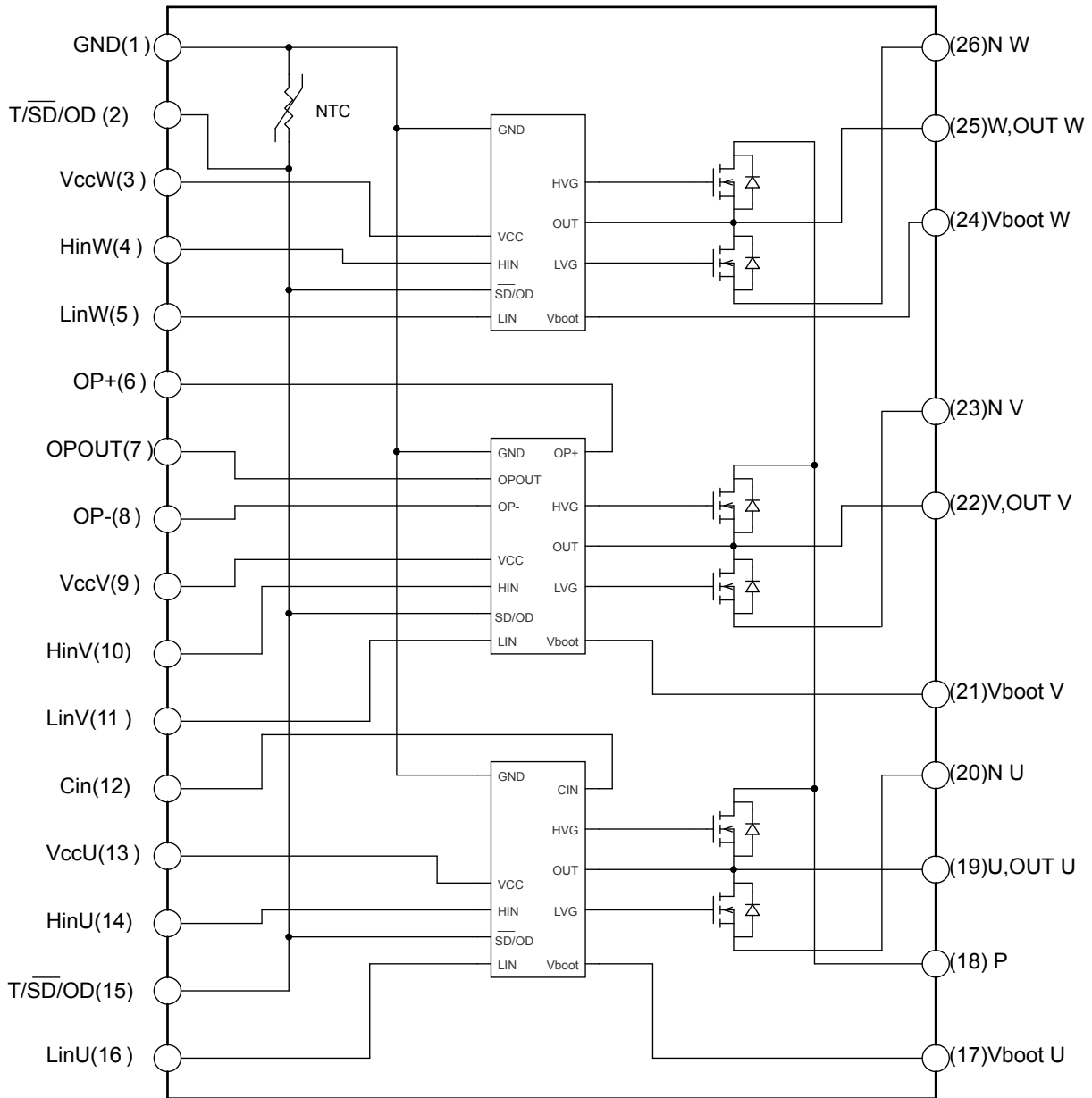

GIPD120120170806SA

**Table 1. Pin description**

Pin	Symbol	Description
1	GND	Ground
2	T/ $\overline{SD}$ /OD	NTC thermistor terminal / shutdown logic input (active low) / open-drain (comparator output)
3	V <sub>CC</sub> W	Low voltage power supply W phase
4	HIN W	High-side logic input for W phase
5	LIN W	Low-side logic input for W phase
6	OP+	Op-amp non inverting input
7	OP <sub>OUT</sub>	Op-amp output
8	OP-	Op-amp inverting input
9	V <sub>CC</sub> V	Low voltage power supply V phase
10	HIN V	High-side logic input for V phase
11	LIN V	Low-side logic input for V phase
12	CIN	Comparator input
13	V <sub>CC</sub> U	Low voltage power supply for U phase
14	HIN U	High-side logic input for U phase
15	T/ $\overline{SD}$ /OD	NTC thermistor terminal / shutdown logic input (active low) / open-drain (comparator output)
16	LIN U	Low-side logic input for U phase
17	V <sub>BOOT</sub> U	Bootstrap voltage for U phase
18	P	Positive DC input
19	U, OUT <sub>U</sub>	U phase output
20	N <sub>U</sub>	Negative DC input for U phase
21	V <sub>BOOT</sub> V	Bootstrap voltage for V phase
22	V, OUT <sub>V</sub>	V phase output
23	N <sub>V</sub>	Negative DC input for V phase
24	V <sub>BOOT</sub> W	Bootstrap voltage for W phase
25	W, OUT <sub>W</sub>	W phase output
26	N <sub>W</sub>	Negative DC input for W phase

Figure 2. Pin layout (top view)

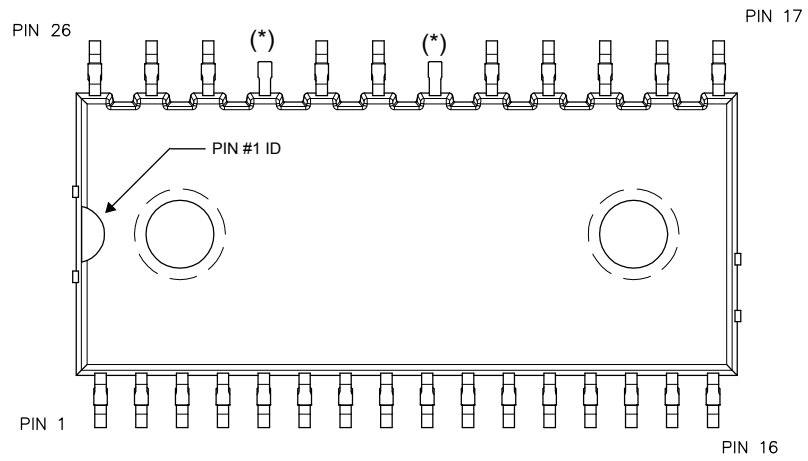

(\* Dummy pin internally connected to P (positive DC input).

## 2 Electrical ratings

### 2.1 Absolute maximum ratings

**Table 2. Inverter part**

Symbol	Parameter	Value	Unit
$V_{DSS}$	MOSFET blocking voltage (or drain-source voltage) for each MOSFET ( $V_{IN}^{(1)} = 0\text{ V}$ )	500	V
$\pm I_D$	Continuous drain current each MOSFET ( $T_C = 25\text{ °C}$ )	2	A
$\pm I_{DP}^{(2)}$	Peak drain current each MOSFET (less than 1 ms)	4	A
$P_{TOT}$	Total power dissipation for each MOSFET ( $T_C = 25\text{ °C}$ )	10.6	W

1. Applied among  $HINx$ ,  $LINx$  and  $GND$  for  $x = U, V, W$
2. Pulse width limited by maximum junction temperature.

**Table 3. Control part**

Symbol	Parameter	Min.	Max.	Unit
$V_{OUT}$	Output voltage applied among $OUT_U$ , $OUT_V$ , $OUT_W$ - GND	$V_{boot} - 21$	$V_{boot} + 0.3$	V
$V_{CC}$	Low voltage power supply	-0.3	21	V
$V_{CIN}$	Comparator input voltage	-0.3	$V_{CC} + 0.3$	V
$V_{op+}$	Op-amp non-inverting input	-0.3	$V_{CC} + 0.3$	V
$V_{op-}$	Op-amp inverting input	-0.3	$V_{CC} + 0.3$	V
$V_{boot}$	Bootstrap voltage	-0.3	620	V
$V_{IN}$	Logic input voltage applied among $HIN$ , $LIN$ and $GND$	-0.3	15	V
$V_{T/SD/OD}$	Open-drain voltage	-0.3	15	V
$dV_{OUT}/dt$	Allowed output slew rate		50	V/ns

**Table 4. Total system**

Symbol	Parameter	Value	Unit
$V_{ISO}$	Isolation withstand voltage applied between each pin and heat sink plate (AC voltage, $t = 60\text{ s}$ )	1000	Vrms
$T_J$	Power chip operating junction temperature range	-40 to 150	°C
$T_C$	Module case operation temperature range	-40 to 125	°C

## 2.2 Thermal data

Table 5. Thermal data

Symbol	Parameter	Value	Unit
$R_{th(j-c)}$	Thermal resistance junction-case single MOSFET	11.7	°C/W
$R_{th(j-a)}$	Thermal resistance junction-ambient (per module)	24	°C/W

### 3 Electrical characteristics

#### 3.1 Inverter part

$T_J = 25\text{ }^\circ\text{C}$  unless otherwise specified

**Table 6. Static**

Symbol	Parameter	Test conditions	Min.	Typ.	Max.	Unit
$I_{DSS}$	Zero-gate voltage drain current	$V_{DS} = 500\text{ V}$ , $V_{CC} = 15\text{ V}$ , $V_{Boot} = 15\text{ V}$			1	mA
$V_{(BR)DSS}$	Drain-source breakdown voltage	$V_{CC} = V_{boot} = 15\text{ V}$ , $V_{IN}^{(1)} = 0\text{ V}$ , $I_D = 1\text{ mA}$	500			V
$R_{DS(on)}$	Static drain-source turn-on resistance	$V_{CC} = V_{boot} = 15\text{ V}$ , $V_{IN}^{(1)} = 0\text{ to }5\text{ V}$ , $I_D = 1.2\text{ A}$		1.5	1.7	$\Omega$
$V_{SD}$	Drain-source diode forward voltage	$V_{IN}^{(1)} = 0$ "logic state", $I_D = 2\text{ A}$		0.9	1.6	V

1. Applied among  $HINx$ ,  $LINx$  and  $GND$  for  $x = U, V, W$ .

**Table 7. Inductive load switching time and energy**

Symbol	Parameter	Test conditions	Min.	Typ.	Max.	Unit
$t_{on}^{(1)}$	Turn-on time	$V_{DD} = 300\text{ V}$ , $V_{CC} = V_{boot} = 15\text{ V}$ , $V_{IN}^{(2)} = 0\text{ to }5\text{ V}$ , $I_D = 1.2\text{ A}$ (see Figure 4. Switching time definition)	-	267	-	ns
$t_{c(on)}^{(1)}$	Crossover time (on)		-	153	-	
$t_{off}^{(1)}$	Turn-off time		-	265	-	
$t_{c(off)}^{(1)}$	Crossover time (off)		-	46	-	
$t_{rr}$	Reverse recovery time		-	192	-	
$E_{on}$	Turn-on switching energy		-	61	-	$\mu\text{J}$
$E_{off}$	Turn-off switching energy	-	4	-		

1.  $t_{ON}$  and  $t_{OFF}$  include the propagation delay time of the internal drive.  $t_{C(ON)}$  and  $t_{C(OFF)}$  are the switching time of MOSFET itself under the internally given gate driving conditions.

2. Applied among  $HINx$ ,  $LINx$  and  $GND$  for  $x = U, V, W$ .

Figure 3. Switching time test circuit

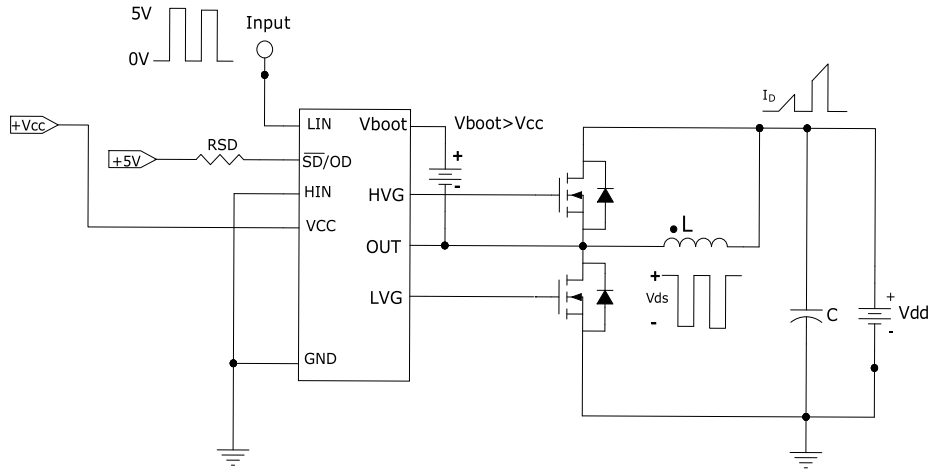

GIPD161120151702RV

Figure 4. Switching time definition

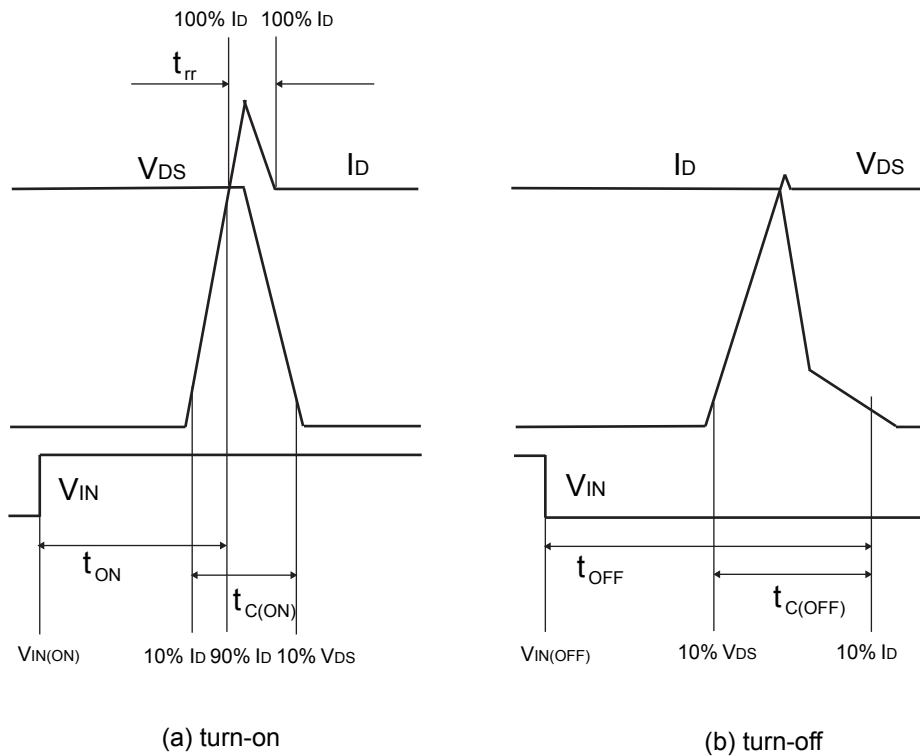

AM09223V2

Figure 4. Switching time definition refers to HIN, LIN inputs (active high).



### 3.2 Control part

$V_{CC} = 15\text{ V}$  unless otherwise specified

**Table 8. Low voltage power supply**

Symbol	Parameter	Test conditions	Min.	Typ.	Max.	Unit
$V_{CC\_hys}$	$V_{CC}$ UV hysteresis		1.2	1.5	1.8	V
$V_{CC\_thON}$	$V_{CC}$ UV turn-ON threshold		11.5	12	12.5	V
$V_{CC\_thOFF}$	$V_{CC}$ UV turn-OFF threshold		10	10.5	11	V
$I_{qccu}$	Undervoltage quiescent supply current	$V_{CC} = 15\text{ V}$ , $T/\overline{SD}/OD = 5\text{ V}$ ; $LIN = 0\text{ V}$ ; $HIN = 0\text{ V}$ , $CIN = 0\text{ V}$			150	$\mu\text{A}$
$I_{qcc}$	Quiescent current	$V_{CC} = 15\text{ V}$ , $T/\overline{SD}/OD = 5\text{ V}$ ; $LIN = 0\text{ V}$ ; $HIN = 0\text{ V}$ , $CIN = 0\text{ V}$			1	mA
$V_{ref}$	Internal comparator (CIN) reference voltage		0.5	0.54	0.58	V

**Table 9. Bootstrapped voltage**

Symbol	Parameter	Test conditions	Min.	Typ.	Max.	Unit
$V_{BS\_hys}$	$V_{BS}$ UV hysteresis		1.2	1.5	1.8	V
$V_{BS\_thON}$	$V_{BS}$ UV turn-ON threshold		11.1	11.5	12.1	V
$V_{BS\_thOFF}$	$V_{BS}$ UV turn-OFF threshold		9.8	10	10.6	V
$I_{QBSU}$	Undervoltage $V_{BS}$ quiescent current	$V_{BS} < 9\text{ V}$ , $T/\overline{SD}/OD = 5\text{ V}$ ; $LIN = 0\text{ V}$ and $HIN = 5\text{ V}$ ; $CIN = 0\text{ V}$		70	110	$\mu\text{A}$
$I_{QBS}$	$V_{BS}$ quiescent current	$V_{BS} = 15\text{ V}$ , $T/\overline{SD}/OD = 5\text{ V}$ ; $LIN = 0\text{ V}$ and $HIN = 5\text{ V}$ ; $CIN = 0\text{ V}$		200	300	$\mu\text{A}$
$R_{DS(on)}$	Bootstrap driver on-resistance	LVG ON		120		$\Omega$

**Table 10. Logic inputs**

Symbol	Parameter	Test conditions	Min.	Typ.	Max.	Unit
$V_{il}$	Low logic level voltage				0.8	V
$V_{ih}$	High logic level voltage		2.25			V
$I_{HINh}$	HIN logic "1" input bias current	$HIN = 15\text{ V}$	20	40	100	$\mu\text{A}$
$I_{HINI}$	HIN logic "0" input bias current	$HIN = 0\text{ V}$			1	$\mu\text{A}$
$I_{LINI}$	LIN logic "1" input bias current	$LIN = 15\text{ V}$	20	40	100	$\mu\text{A}$
$I_{LINh}$	LIN logic "0" input bias current	$LIN = 0\text{ V}$			1	$\mu\text{A}$
$I_{SDh}$	$\overline{SD}$ logic "0" input bias current	$\overline{SD} = 15\text{ V}$	200	350	500	$\mu\text{A}$
$I_{SDI}$	$\overline{SD}$ logic "1" input bias current	$\overline{SD} = 0\text{ V}$			3	$\mu\text{A}$
Dt	Dead time	See <a href="#">Figure 9. Dead time and interlocking waveform definitions</a>		180		ns

**Table 11. Op-amp characteristics**

Symbol	Parameter	Test conditions	Min.	Typ.	Max.	Unit
$V_{io}$	Input offset voltage	$V_{ic} = 0\text{ V}$ , $V_o = 7.5\text{ V}$			6	mV
$I_{io}$	Input offset current	$V_{ic} = 0\text{ V}$ , $V_o = 7.5\text{ V}$		4	40	nA
$I_{ib}$	Input bias current <sup>(1)</sup>			100	200	nA
$V_{OL}$	Low level output voltage	$R_L = 10\text{ k}\Omega$ to $V_{CC}$		75	150	mV
$V_{OH}$	High level output voltage	$R_L = 10\text{ k}\Omega$ to GND	14	14.7		V
$I_o$	Output short-circuit current	Source, $V_{id} = +1\text{ V}$ ; $V_o = 0\text{ V}$	16	30		mA
		Sink, $V_{id} = -1\text{ V}$ ; $V_o = V_{CC}$	50	80		mA
SR	Slew rate	$V_i = 1 - 4\text{ V}$ ; $C_L = 100\text{ pF}$ ; unity gain	2.5	3.8		V/ $\mu$ s
GBWP	Gain bandwidth product	$V_o = 7.5\text{ V}$	8	12		MHz
$A_{vd}$	Large signal voltage gain	$R_L = 2\text{ k}\Omega$	70	85		dB
SVR	Supply voltage rejection ratio	vs. $V_{CC}$	60	75		dB
CMRR	Common mode rejection ratio		55	70		dB

1. The direction of the input current is out of the IC.

**Table 12. Sense comparator characteristics**

Symbol	Parameter	Test conditions	Min.	Typ.	Max.	Unit
$I_{ib}$	Input bias current	$V_{CIN} = 1\text{ V}$			1	$\mu$ A
$V_{od}$	Open-drain low level output voltage	$I_{od} = 3\text{ mA}$			0.5	V
$R_{ON\_OD}$	Open-drain low level output resistance	$I_{od} = 3\text{ mA}$		166		$\Omega$
$R_{PD\_SD}$	$\overline{SD}$ pull-down resistor <sup>(1)</sup>			125		k $\Omega$
$t_{d\_comp}$	Comparator delay	T/ $\overline{SD}$ /OD pulled to 5 V through 100 k $\Omega$ resistor		90	130	ns
SR	Slew rate	$C_L = 180\text{ pF}$ ; $R_{pu} = 5\text{ k}\Omega$		60		V/ $\mu$ s
$t_{sd}$	Shutdown to high / low-side driver propagation delay	$V_{OUT} = 0\text{ V}$ , $V_{boot} = V_{CC}$ , $V_{IN} = 0$ to 3.3 V	50	125	200	ns
$t_{isd}$	Comparator triggering to high / low-side driver turn-off propagation delay	Measured applying a voltage step from 0 V to 3.3 V to pin CIN	50	200	250	

1. Equivalent values are as a result of the resistances of three drivers in parallel.

**Table 13. Truth table**

Conditions	Logic input (V <sub>I</sub> )			Output	
	T/ $\overline{\text{SD}}$ /OD	LIN	HIN	LVG	HVG
Shutdown enable half-bridge tri-state	L	X <sup>(1)</sup>	X <sup>(1)</sup>	L	L
Interlocking half-bridge tri-state	H	H	H	L	L
0 "logic state" half-bridge tri-state	H	L	L	L	L
1 "logic state" low-side direct driving	H	H	L	H	L
1 "logic state" high-side direct driving	H	L	H	L	H

1. X: do not care.

### 3.2.1 NTC thermistor

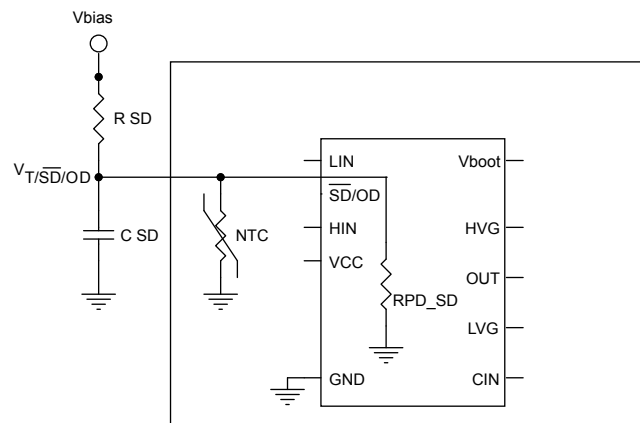
**Figure 5. Internal structure of  $\overline{\text{SD}}$  and NTC**

$R_{\text{PD\_SD}}$ : equivalent value as result of resistances of three drivers in parallel.

Figure 6. Equivalent resistance (NTC//R<sub>PD\_SD</sub>)

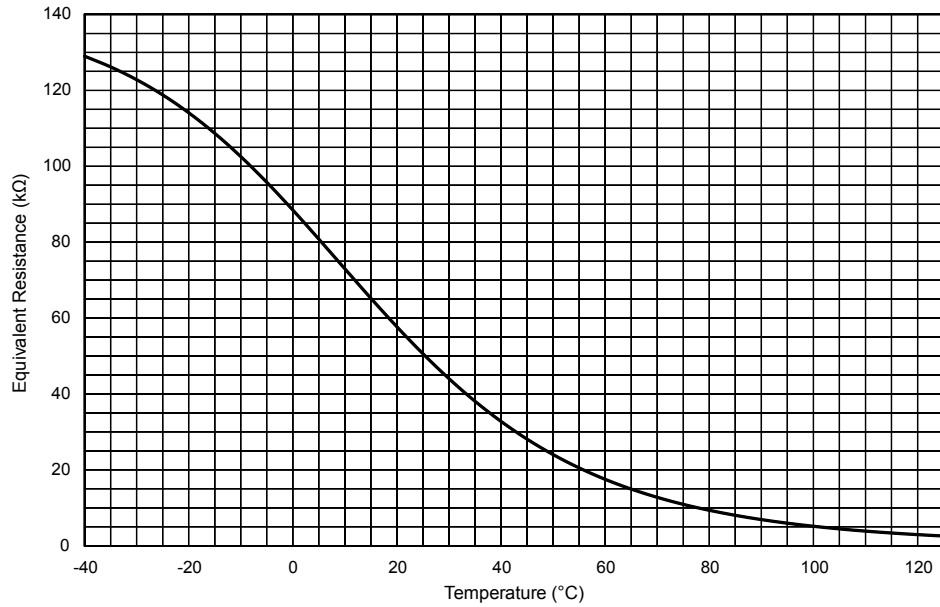

Figure 7. Equivalent resistance (NTC//R<sub>PD\_SD</sub>) zoom

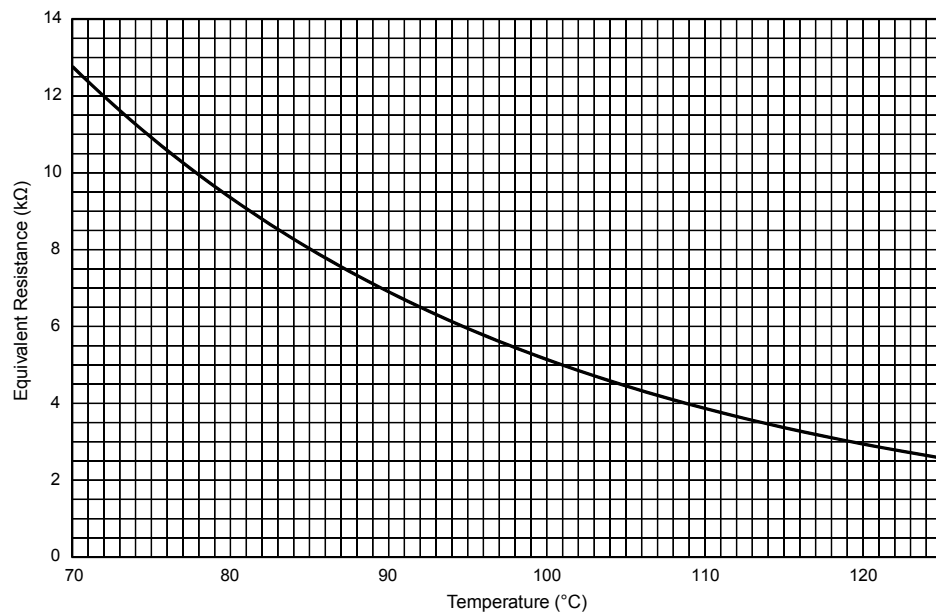
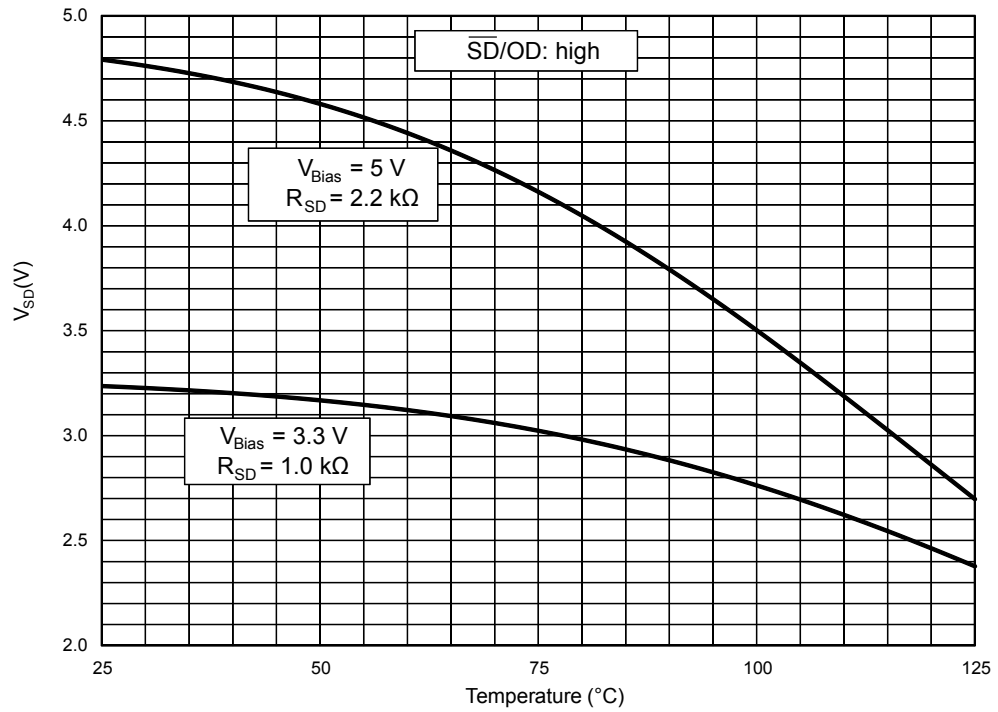
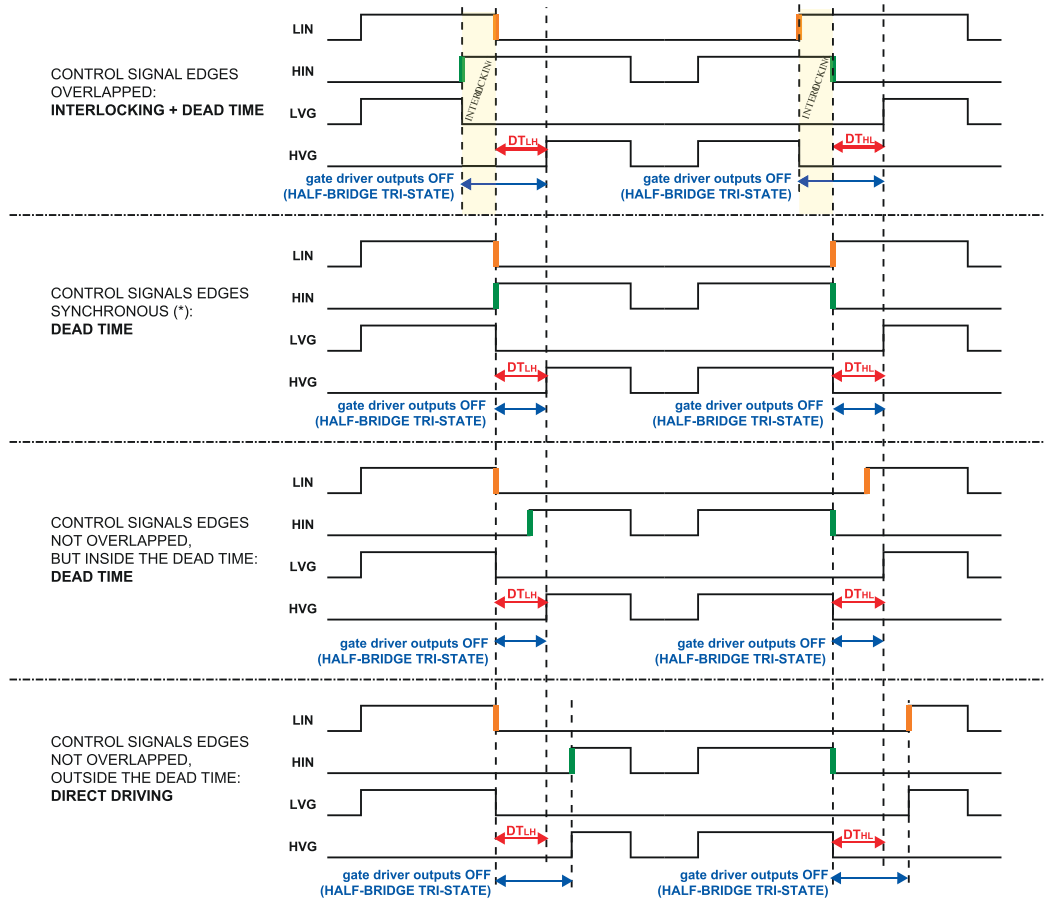

Figure 8. Voltage of T/ $\overline{SD}$ /OD pin according to NTC temperature



### 3.3 Waveform definitions

Figure 9. Dead time and interlocking waveform definitions



## 4 Shutdown function

The device is equipped with three half-bridge IC gate drivers and integrates a comparator for fault detection. The comparator has an internal voltage reference  $V_{REF}$  connected to the inverting input, while the non-inverting input pin (CIN) can be connected to an external shunt resistor for current monitoring.

Since the comparator is embedded in the U IC gate driver, in case of fault it disables directly the U outputs, whereas the shutdown of V and W IC gate drivers depends on the RC value of the external SD circuitry, which fixes the disabling time.

For an effective design of the shutdown circuit, please refer to Application note AN4966.

**Figure 10. Shutdown timing waveforms**

GADG250120171515FSR

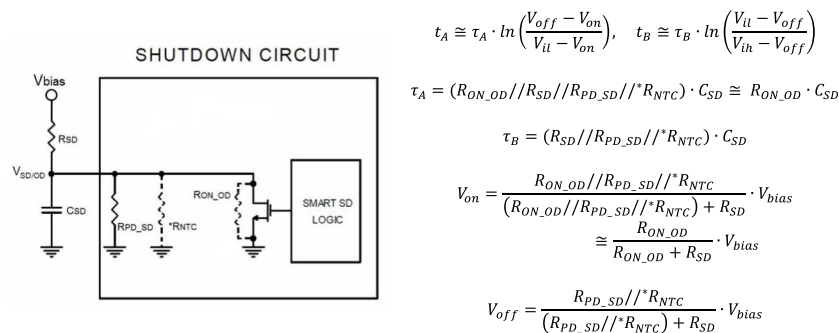
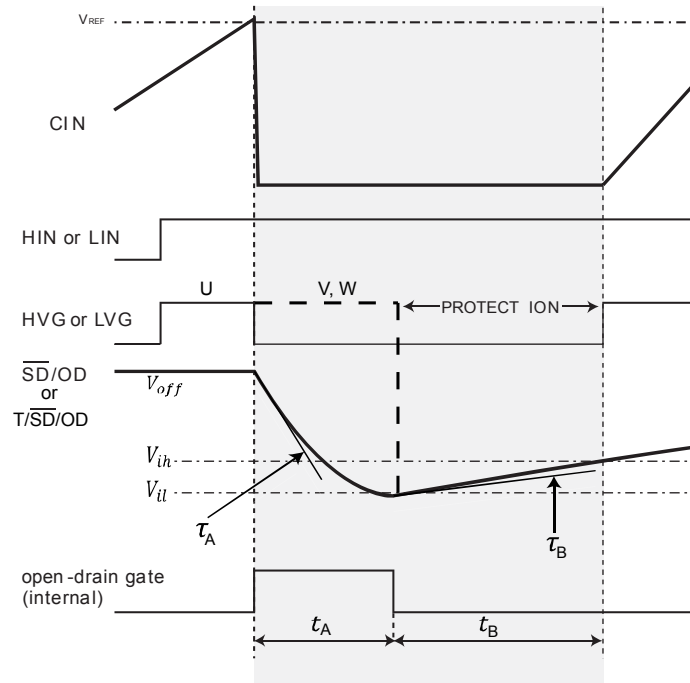

$R_{SD}$  and  $C_{SD}$  external circuitry must be designed to ensure  $V_{on} < V_{il}$  &  $V_{off} > V_{ih}$

Please refer to AN4966 for further details.

\*  $R_{NTC}$  to be considered only when the NTC is internally connected to the T/SD/OD pin.

## 5 Application circuit example

Figure 11. Application circuit example

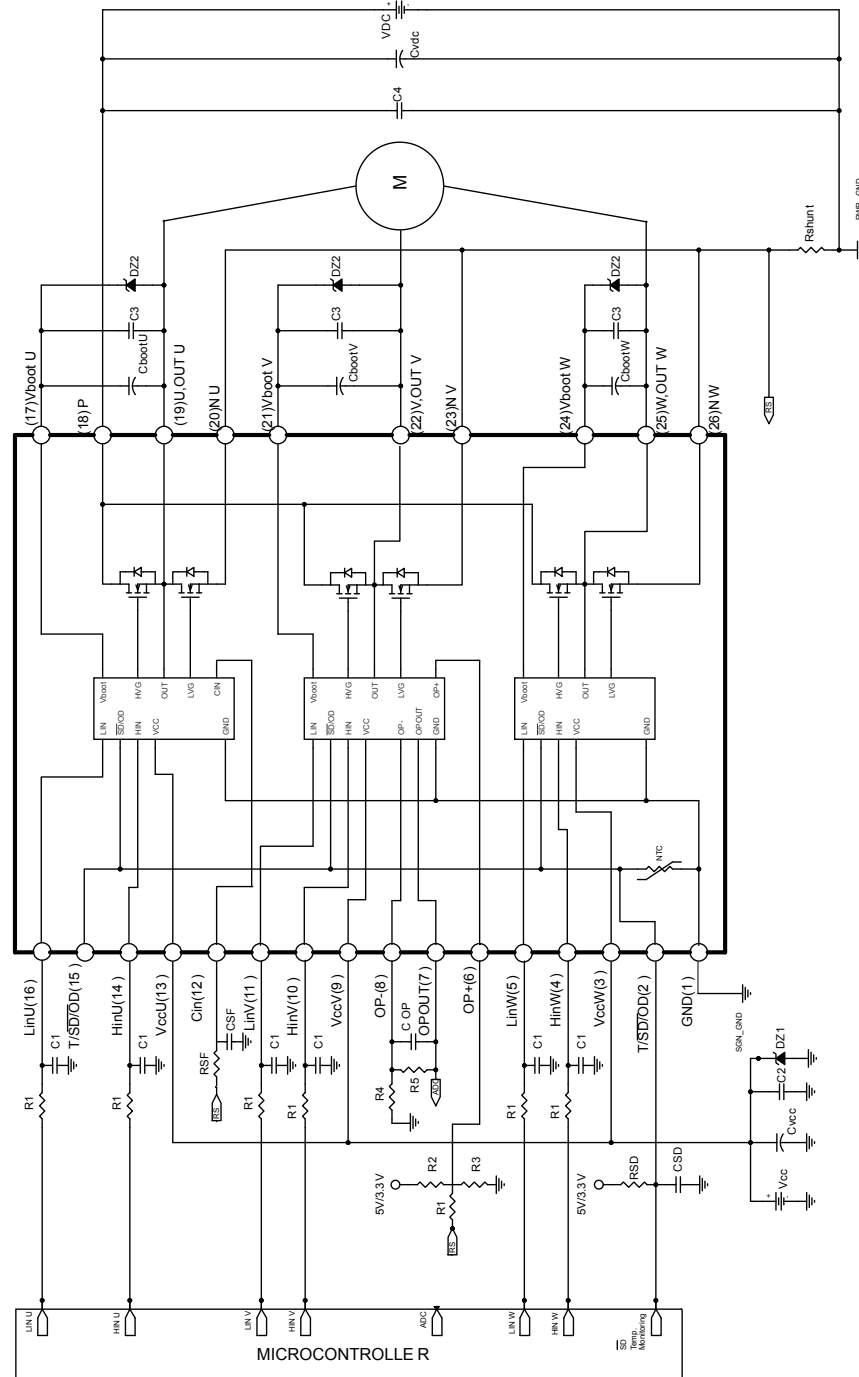

GADG100620160912FSR

Application designers are free to use a different scheme according to the device specifications.



## 5.1 Guidelines

- Input signals HIN, LIN are active high logic. A 375 kΩ (typ.) pull-down resistor is built-in for each input. To avoid input signal oscillation, the wiring of each input should be as short as possible, and the use of RC filters ( $R_1$ ,  $C_1$ ) on each input signal is suggested. The filters should be with a time constant of about 100 ns and placed as close as possible to the IPM input pins.
- The use of a bypass capacitor  $C_{VCC}$  (aluminum or tantalum) can reduce the transient circuit demand on the power supply. Also, to reduce any high-frequency switching noise distributed on the power lines, a decoupling capacitor  $C_2$  (100 to 220 nF, with low ESR and low ESL) should be placed as close as possible to the  $V_{cc}$  pin and in parallel with the bypass capacitor.
- The use of an RC filter ( $R_{SF}$ ,  $C_{SF}$ ) is recommended to prevent protection circuit malfunction. The time constant ( $R_{SF} \times C_{SF}$ ) should be set to 1 μs and the filter must be placed as close as possible to the  $C_{IN}$  pin.
- The  $\overline{SD}$  is an input/output pin (open-drain type if it is used as output). A built-in thermistor NTC is internally connected between the  $\overline{SD}$  pin and GND. The voltage  $V_{SD-GND}$  decreases as the temperature increases, due to the pull-up resistor  $R_{SD}$ . In order to keep the voltage always higher than the high-level logic threshold, the pull-up resistor should be set to 1 kΩ or 2.2 kΩ for 3.3 V or 5 V MCU power supply, respectively. The capacitor  $C_{SD}$  of the filter on  $\overline{SD}$  should be fixed no higher than 3.3 nF in order to assure the  $\overline{SD}$  activation time  $\tau_A \leq 500$  ns. Besides, the filter should be placed as close as possible to the  $\overline{SD}$  pin.
- The decoupling capacitor  $C_3$  (from 100 to 220 nF, ceramic with low ESR and low ESL), in parallel with each  $C_{boot}$ , filters high-frequency disturbance. Both  $C_{boot}$  and  $C_3$  (if present) should be placed as close as possible to the U, V, W and  $V_{boot}$  pins. Bootstrap negative electrodes should be connected to U, V, W terminals directly and separated from the main output wires.
- To avoid overvoltage on the  $V_{cc}$  pin, a Zener diode (Dz1) can be used. Similarly on the  $V_{boot}$  pin, a Zener diode (Dz2) can be placed in parallel with each  $C_{boot}$ .
- The use of the decoupling capacitor  $C_4$  (100 to 220 nF, with low ESR and low ESL) in parallel with the electrolytic capacitor  $C_{vdc}$  is useful to prevent surge destruction. Both capacitors  $C_4$  and  $C_{vdc}$  should be placed as close as possible to the IPM ( $C_4$  has priority over  $C_{vdc}$ ).
- By integrating an application-specific type HVIC inside the module, direct coupling to the MCU terminals without an opto-couplers is possible.
- Low-inductance shunt resistors have to be used for phase leg current sensing.
- In order to avoid malfunctions, the wiring on N pins, the shunt resistor and  $P_{WR\_GND}$  should be as short as possible.
- The connection of  $SGN\_GND$  to  $PWR\_GND$  on one point only (close to the shunt resistor terminal) can reduce the impact of power ground fluctuation.

These guidelines ensure the device specifications for application designs. For further details, please refer to the relevant application note.

**Table 14. Recommended operating conditions**

Symbol	Parameter	Test conditions	Min.	Typ.	Max.	Unit
$V_{PN}$	Supply voltage	Applied among P-Nu, Nv, Nw		300	400	V
$V_{CC}$	Control supply voltage	Applied to $V_{CC-GND}$	13.5	15	18	V
$V_{BS}$	High-side bias voltage	Applied to $V_{BOOTx-OUT}$ for $x = U, V, W$	13		18	V
$t_{dead}$	Blanking time to prevent arm-short	For each input signal	1			μs
$f_{PWM}$	PWM input signal	$-40\text{ }^\circ\text{C} < T_C < 100\text{ }^\circ\text{C}$ $-40\text{ }^\circ\text{C} < T_J < 125\text{ }^\circ\text{C}$			25	kHz
$T_C$	Case operation temperature				100	°C

## 6 Package information

In order to meet environmental requirements, ST offers these devices in different grades of **ECOPACK** packages, depending on their level of environmental compliance. ECOPACK specifications, grade definitions and product status are available at: [www.st.com](http://www.st.com). ECOPACK is an ST trademark.

### 6.1 NSDIP-26L package information

Figure 12. NSDIP-26L package outline

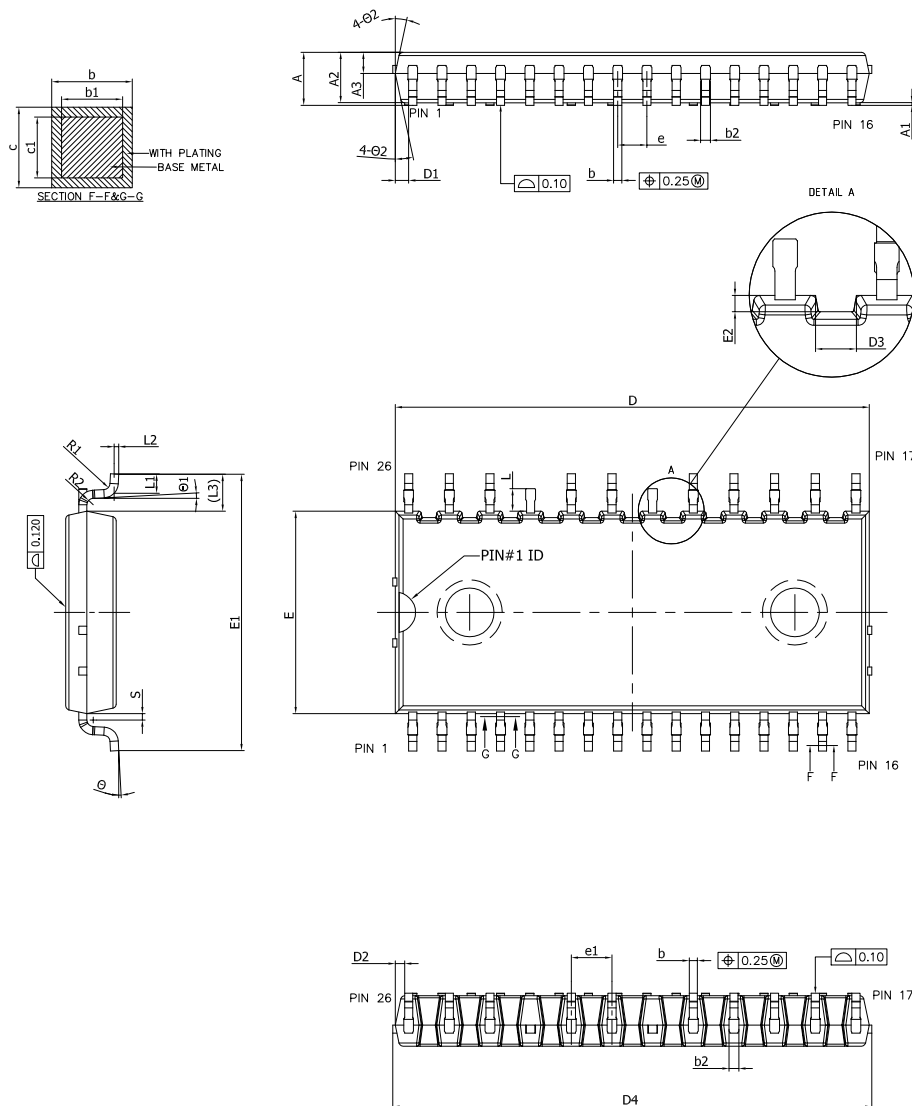

8374968\_4

**Table 15. NSDIP-26L package mechanical data**

Dim.	mm		
	Min.	Typ.	Max.
A			3.45
A1	0.10		0.25
A2	3.00	3.10	3.20
A3	1.10	1.30	1.50
b	0.47		0.57
b1	0.45	0.50	0.55
b2	0.63		0.67
c	0.47		0.57
c1	0.45	0.50	0.55
D	29.05	29.15	29.25
D1	0.70		
D2	0.45		
D3	0.90		
D4			29.65
E	12.35	12.45	12.55
E1	16.70	17.00	17.30
E2	0.35		
e	1.70	1.80	1.90
e1	2.40	2.50	2.60
L	1.24	1.39	1.54
L1	1.00	1.15	1.30
L2	0.25 BSC		
L3	2.275 REF		
R1	0.25	0.40	0.55
R2	0.25	0.40	0.55
S		0.39	0.55
θ	0°		8°
θ1	3° BSC		
θ2	10°	12°	14°

Figure 13. NSDIP-26L recommended footprint (dimensions are in mm)

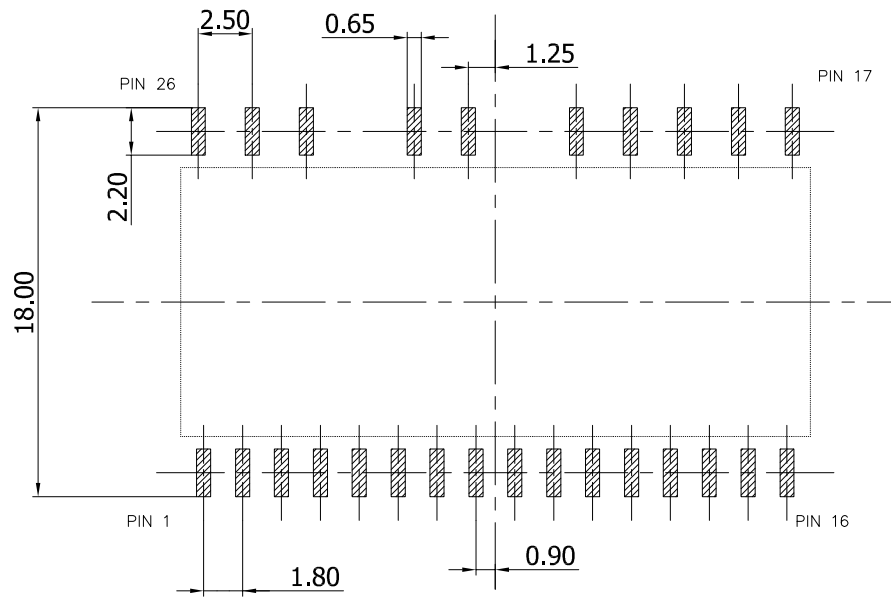

8374968\_4\_fp

## Revision history

**Table 16. Document revision history**

Date	Revision	Changes
19-Apr-2017	1	Initial release
04-Jan-2018	2	Datasheet status promoted from preliminary to production data. Updated features on cover page. Updated <i>Table 3: "Inverter part"</i> , <i>Table 5: "Total system"</i> , <i>Table 6: "Thermal data"</i> and <i>Table 13: "Sense comparator characteristics"</i> . Updated <i>Section 6.1: "NSDIP-26L package information"</i> .
22-Aug-2019	3	Removed maturity status indication from cover page. Modified <i>Table 2. Inverter part</i> , <i>Table 5. Thermal data</i> , <i>Table 10. Logic inputs</i> , <i>Section 4 Shutdown function</i> and <i>Section 5.1 Guidelines</i> . Updated <i>Section 6.1 NSDIP-26L package information</i> . Minor text changes.

## Contents

<b>1</b>	<b>Internal schematic diagram and pin configuration</b>	<b>2</b>
<b>2</b>	<b>Electrical ratings</b>	<b>5</b>
2.1	Absolute maximum ratings	5
2.2	Thermal data	6
<b>3</b>	<b>Electrical characteristics</b>	<b>7</b>
3.1	Inverter part	7
3.2	Control part	9
3.2.1	NTC thermistor	11
3.3	Waveform definitions	13
<b>4</b>	<b>Shutdown function</b>	<b>15</b>
<b>5</b>	<b>Application circuit example</b>	<b>16</b>
5.1	Guidelines	17
<b>6</b>	<b>Package information</b>	<b>18</b>
6.1	NSDIP-26L package information	18
	<b>Revision history</b>	<b>21</b>

**IMPORTANT NOTICE – PLEASE READ CAREFULLY**

STMicroelectronics NV and its subsidiaries (“ST”) reserve the right to make changes, corrections, enhancements, modifications, and improvements to ST products and/or to this document at any time without notice. Purchasers should obtain the latest relevant information on ST products before placing orders. ST products are sold pursuant to ST’s terms and conditions of sale in place at the time of order acknowledgement.

Purchasers are solely responsible for the choice, selection, and use of ST products and ST assumes no liability for application assistance or the design of Purchasers’ products.

No license, express or implied, to any intellectual property right is granted by ST herein.

Resale of ST products with provisions different from the information set forth herein shall void any warranty granted by ST for such product.

ST and the ST logo are trademarks of ST. For additional information about ST trademarks, please refer to [www.st.com/trademarks](http://www.st.com/trademarks). All other product or service names are the property of their respective owners.

Information in this document supersedes and replaces information previously supplied in any prior versions of this document.

© 2019 STMicroelectronics – All rights reserved