

P/N OF ADAPTER	MATERIAL OF SPLIT SLEEVE	COLOR OF ADAPTER SHELL
106171-0100	CERAMIC	BLACK
106170-0120	CERAMIC	GREEN
106170-0150	CERAMIC	BLUE
106170-0153*		
106171-0150	CERAMIC	

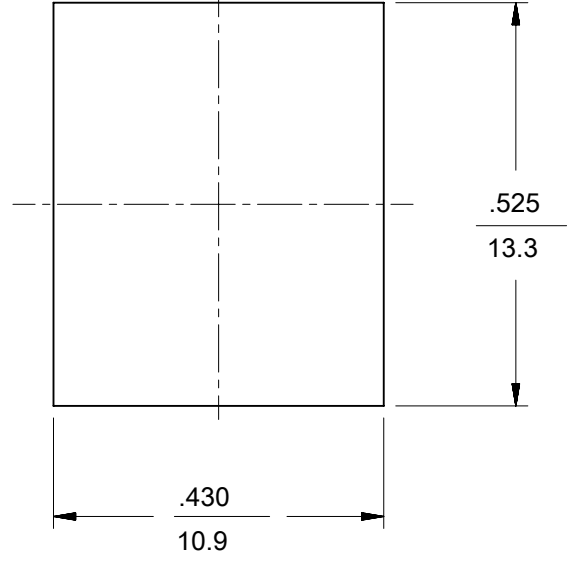
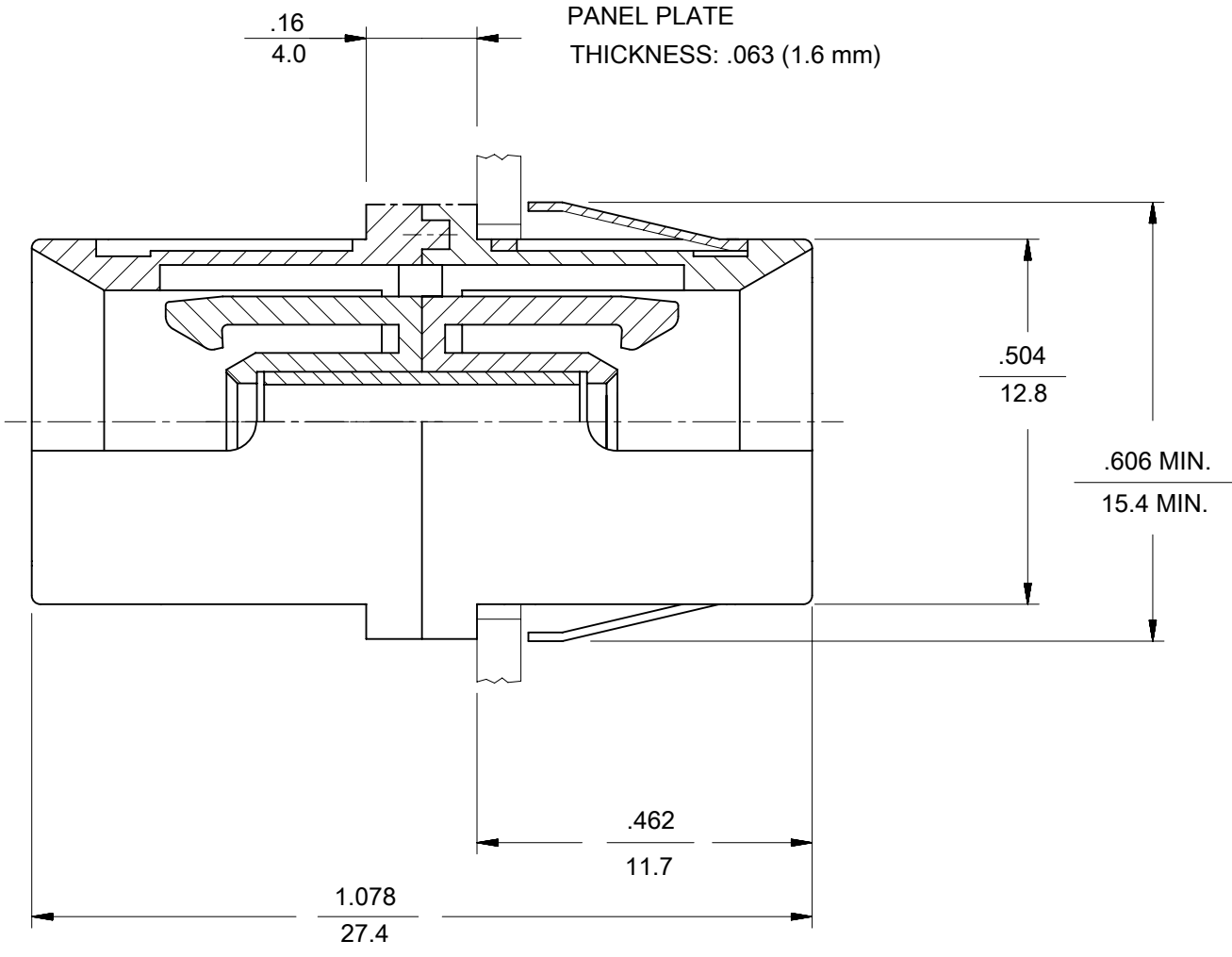
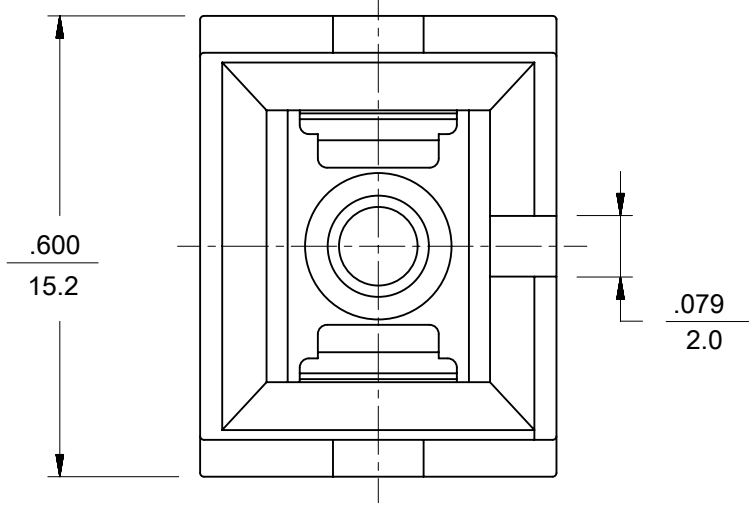
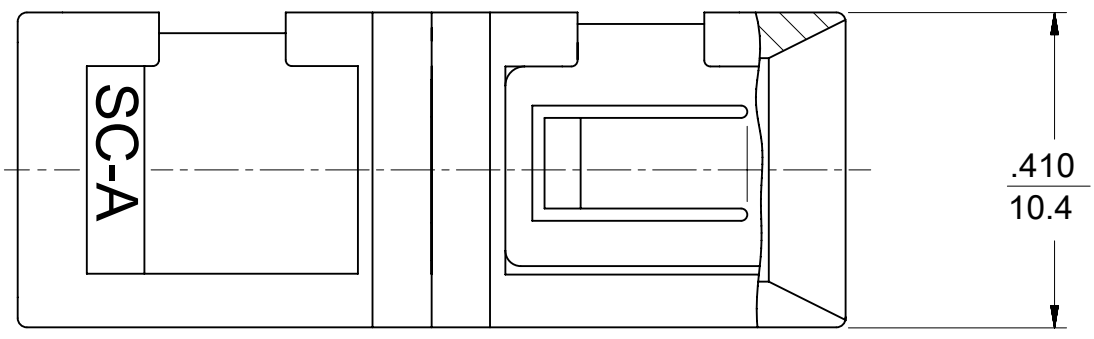

RECOMMENDED MOUNTING HOLE

- NOTES:
- DUST CAPS ARE NOT SHOWN BUT INCLUDED.
  - P/N 106170-0153 ARE BULK PACKED ADAPTER KITS OF 100 PCS.
  - PLASTICS USED IN ADAPTERS ARE UL-94 V-0 RATED.

THIS DRAWING CONTAINS INFORMATION THAT IS PROPRIETARY TO MOLEX ELECTRONIC TECHNOLOGIES, LLC AND SHOULD NOT BE USED WITHOUT WRITTEN PERMISSION										
DIMENSION UNITS	SCALE	CURRENT REV DESC: REMOVED OBSOLETE PART NUMBERS AS PER PCN#512063.								
INCH/MM	4:1	<p style="text-align: center;"><b>molex</b></p> <p style="text-align: center;">SC SMALL FLANGE ADAPTER</p> <p style="text-align: center;">PRODUCT CUSTOMER DRAWING</p>								
GENERAL TOLERANCES (UNLESS SPECIFIED)										
ANGULAR TOL	± 0.5°	EC NO: 713759	2022/08/22							
4 PLACES	±	DRWN: SANTHN	2022/10/07							
3 PLACES	±	CHKD: GB	2022/10/07							
2 PLACES	±	APPR: GB	2022/10/07							
1 PLACE	±	INITIAL REVISION:		2005/11/29						
0 PLACES	±	DRWN: PGIBLIN	2005/11/29							
DRAFT WHERE APPLICABLE MUST REMAIN WITHIN DIMENSIONS		THIRD ANGLE PROJECTION	DRAWING	SERIES	MATERIAL NUMBER	CUSTOMER	DOCUMENT NUMBER	DOC TYPE	DOC PART	REVISION
			B-SIZE	106170	SEE TABLE	GENERAL MARKET	SD-10617X-01X0	PSD	001	C1
										SHEET NUMBER
										1 OF 1