

PART NUMBER	REV	FIRST USED
687833-3	K	565435-5

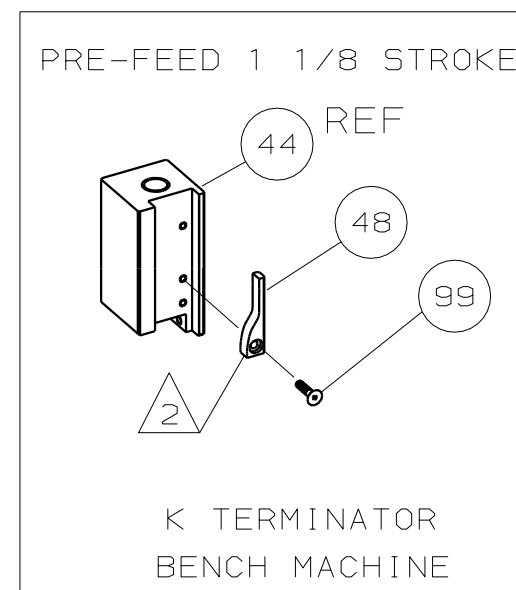
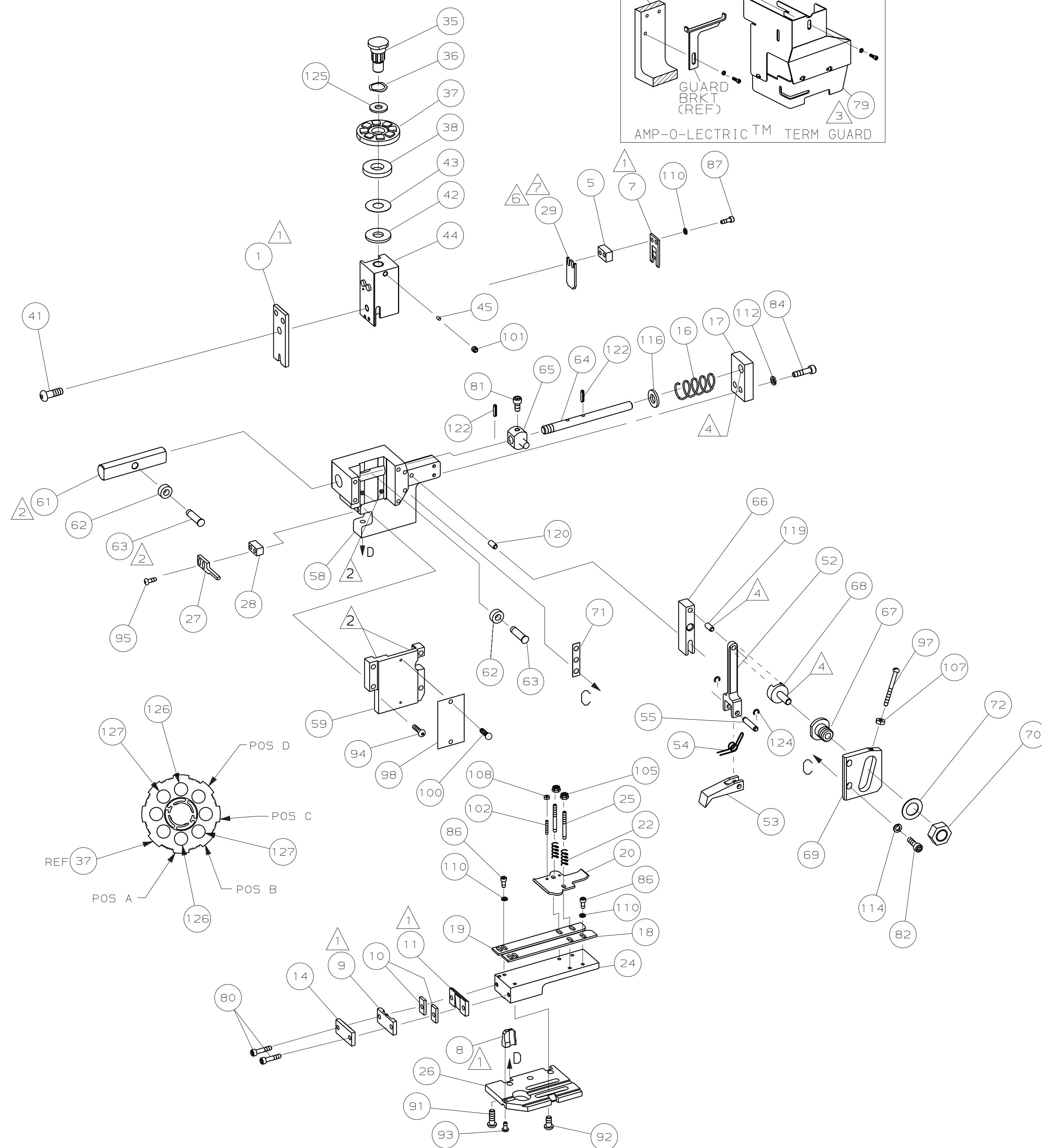
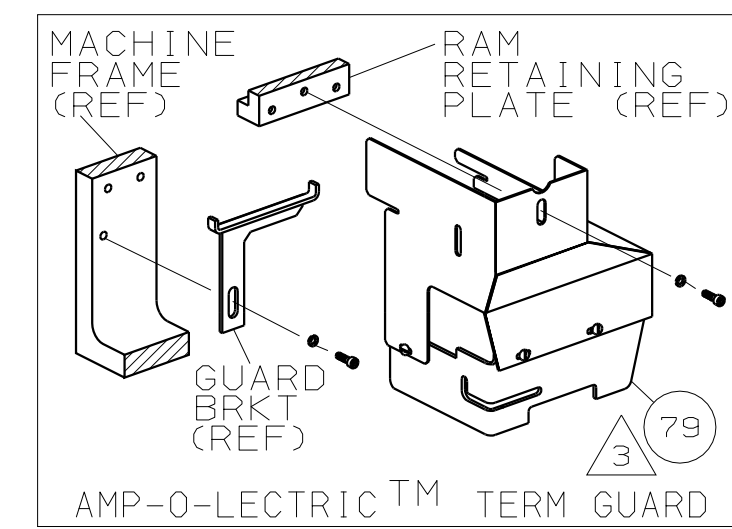

- 1 RECOMMENDED SPARE PARTS.
- 2 GREASE LIGHTLY.
- 3 GUARD MUST BE IN PLACE WHEN OPERATING APPLICATOR IN A BENCH MACHINE.
- 4 LUBRICATE DAILY USING NO. 20 MACHINE OIL.
- 5. ITEMS WITH QTY OF REF SPECIFIED (EXCEPT ITEMS 78 AND 79) ARE USED ON ITEM 32.
- 6 ADJUST ITEM 29 TO ACHIEVE PROPER BEND WHEN CHANGING WIRE SIZES.
- 7 FIXED FORMING TOOL P/N 1633347-1 FOR 10 AWG WIRE AND P/N 1633347-2 FOR 12 AWG WIRE MAY BE SUBSTITUTED FOR ITEM 29 (P/N 690759-1).

TERMINAL NAME:		CRIMPING DATA			
FLANGED SPADE		PAD LTR	CRIMP HEIGHT	WIRE SIZE	
	40891-A	A	.120 ±.002	10	
	41495-A	B	.108 ±.002	12	
	42113-A	C	NOT	USED	
		D	NOT	USED	
		CRIMP	SIZE	TYPE	RANGE
		WIRE	.180	F	12-10
		INSUL	-	-	-
		FEED	.800	APPL INST	408-8039
				SET UP GAGE	458638-1
				LAYOUT	26A
TERM APPL SPEC	114-2084	WIRE STRIP LENGTH	.220-.250		

					129
2	-	C	8-354778-3	PIN, WIRE DISC (.2910)B	128
2	-	C	5-354778-5	PIN, WIRE DISC (.2770)A	126
1	-	A	986950-1	WASHER, FLAT PRECISION	125
REF	-	A	21045-3	RING, RET "C" (Ø.187)FD PIN	124
					123
REF	-	A	5-21028-1	PIN, STD SPRING (Ø.12)FD ADJ ROD	122
					121
REF	-	A	1-21030-7	PIN, DOWEL (Ø.187x1.50)HSG	120
REF	-	A	1-21030-1	PIN, DOWEL (Ø.187x.50)LEVER	119
					118
					117
REF	-	A	21899-4	WASHER, FLAT (Ø5/16) SCR ADJ	116
					115
REF	-	A	21024-5	WASHER, LOCK (NO.10)FD ADJ PL	114
					113
REF	-	A	21024-5	WASHER, LOCK (NO.10)FD ROD GDE	112
					111
6	-	A	21024-4	WASHER, LOCK (NO.8) SHEAR BL	110
					109
2	-	A	21018-4	NUT, HEX (4-40) DRAG	108
REF	-	A	21018-5	NUT, HEX (6-32)FD ADJ PL	107
					106
2	-	A	21022-2	NUT, HEX SL (8-32) DRAG STUD	105
					104
					103
2	-	A	2-21006-6	SCR, SKT SET (4-40x.62) DRAG	102
1	-	A	21009-2	SCR, SKT SET (1/4-20x.25) RAM	101
2	-	A	21017-2	SCR, DRIVE (#2x.19) ID PLATE	100
1	-	A	1-21002-7	SCR, BHC (6-32x.38) CAM	99
1	-	B	461264-1	PLATE, IDENTIFICATION	98
REF	-	A	6-23715-5	SCR, PAN HD (6-32x1.50)FEED ADJ	97
					96
2	-	A	2-21002-2	SCR, BHC (8-32x.50) STRIPPER	95
REF	-	A	2-21002-9	SCR, BHC (10-32x.75)HSG CAP	94
1	-	A	22733-8	SCR, BHC (8-32x.38 LW) ANVIL	93
4	-	A	3-21002-3	SCR, BHC (1/4-20x.50) ST GD PL	92
REF	-	A	2-22733-8	SCR, BHC (1/4-20x.62) BASE PL	91
					90
					89
					88
2	-	A	2-21000-7	SCR, SHC (8-32x.50) SLUG BLADE	87
4	-	A	2-21000-6	SCR, SHC (8-32x.38) STRIP GUIDE	86
					85
REF	-	A	3-21000-7	SCR, SKT CAP (10-32x.75)FD GDE	84
					83
REF	-	A	3-21000-6	SCR, SKT CAP (10-32x.62)FD ADJ P	82
REF	-	A	3-21000-4	SCR, SKT CAP (10-32x.38)PIVOT BL	81
2	-	A	3-21002-0	SCR, BHC (10-32x.88) SH PL	80
REF	-	A	455745-1	GUARD, WINDOW	79
					78
					77
					76
					75
					74
					73
REF	-	A	458109-1	WASHER, FLAT (SPECIAL)	72
REF	-	A	690517-1	SPACER	71
					70
					69
					68
					67
					66
					65
					64
					63
					62
					61
					60
					59
					58
					57
					56
					55
					54
					53
					52
					51
					50
					49
1	-	B	690602-5	CAM, PRE FEED 1 1/8 ST	48
					47
					46
1	-	A	690191-1	PLUG, NYLON	45
1	-	C	455674-1	RAM	44
1	-	A	690125-1	WASHER, LAMINATED	43
1	-	A	690124-7	WASHER, RAM	42
1	-	A	7-21002-9	BOLT, CRIMPER (5/16-24x1.00)	41
					40
					39
1	-	A	690223-2	SPACER, INSULATION DISC	38
1	-	D	354777-1	WIRE DISC, PLASTIC	37
1	-	A	22480-5	WASHER, SPRING	36
1	-	B	690212-1	POST, RAM	35
					34
					33
1	-	D	458980-2	APPLICATOR, BASIC (SUB ASSY)	32
					31
					30
1	-	B	690759-1	TOOL, FLANGING	29
1	-	B	3-690451-2	SPACER, STRIPPER	28
1	-	A	240639-1	STRIPPER	27
REF	-	C	455676-1	PLATE, BASE	26
2	-	A	22354-8	DRAG, STUD	25
1	-	B	455678-6	PLATE, STRIP GUIDE	24
					23
2	-	A	4-22281-1	SPRING, DRAG	22
					21
1	-	A	454177-1	DRAG, STOCK	20
1	-	B	458030-4	GUIDE, STRIP (REAR)	19
1	-	C	458031-4	GUIDE, STRIP (FRONT)	18
REF	-	A	454178-1	GUIDE, FEED ROD	17
REF	-	A	4-22284-9	SPRING, FEED RETURN	16
					15
1	-	B	690783-5	PLATE, RETAINING	14
					13
					12
1	-	B	1-240644-1	PLATE, REAR SHEAR	11
2	-	C	1-240645-2	SPACER, SHEAR PLATE	10
1	-	B	690784-7	PLATE, FRONT SHEAR	9
1	-	D	240654-3	ANVIL	8
1	-	B	6-240651-7	BLADE, SLUG	7
					6
1	-	C	4-240641-8	SPACER, SLUG BLADE	5
					4
					3
					2
1	-	C	456428-2	CRIMPER, WIRE	1

-3	BENCH MODEL K	MECH PRE FEED
----	---------------	---------------

REF					
REF	-	A	22594-8	NUT, HEX	70
REF	-	B	240628-1	PLATE, ADJ	69
REF	-	B	240626-1	SHAFT, PIVOT	68
REF	-	B	240633-1	BUSHING	67
REF	-	A	455680-1	LEVER, INTERMEDIATE	66
REF	-	B	240629-1	BLOCK, PIVOT	65
REF	-	A	240632-2	SCR, ADJ	64
REF	-	B	240659-3	PIN, CAM ROLLER	63
REF	-	B	240658-1	CAM, ROLLER	62
REF	-	B	454398-1	ROD, FEED	61
					60
REF	-	C	454220-1	CAP, RAM	59
REF	-	D	453736-1	HOUSING	58
					57
					56
REF	-	B	240624-1	PIN, FEED FINGER	55
REF	-	B	691499-1	SPRING, FEED FINGER	54
REF	-	B	240635-1	FINGER, FEED	53
REF	-	B	240634-3	LEVER, TERMINAL	52
					51
					50
					49
1	-	B	690602-5	CAM, PRE FEED 1 1/8 ST	48
					47
					46
1	-	A	690191-1	PLUG, NYLON	45
1	-	C	455674-1	RAM	44
1	-	A	690125-1	WASHER, LAMINATED	43
1	-	A	690124-7	WASHER, RAM	42
1	-	A	7-21002-9	BOLT, CRIMPER (5/16-24x1.00)	41
					40
					39
1	-	A	690223-2	SPACER, INSULATION DISC	38
1	-	D	354777-1	WIRE DISC, PLASTIC	37
1	-	A	22480-5	WASHER, SPRING	36
1	-	B	690212-1	POST, RAM	35
					34
					33
1	-	D	458980-2	APPLICATOR, BASIC (SUB ASSY)	32
					31
					30
1	-	B	690759-1	TOOL, FLANGING	29
1	-	B	3-690451-2	SPACER, STRIPPER	28
1	-	A	240639-1	STRIPPER	27
REF	-	C	455676-1	PLATE, BASE	26
2	-	A	22354-8	DRAG, STUD	25
1	-	B	455678-6	PLATE, STRIP GUIDE	24
					23
2	-	A	4-22281-1	SPRING, DRAG	22
					21
1	-	A	454177-1	DRAG, STOCK	20
1	-	B	458030-4	GUIDE, STRIP (REAR)	19
1	-	C	458031-4	GUIDE, STRIP (FRONT)	18
REF	-	A	454178-1	GUIDE, FEED ROD	17
REF	-	A	4-22284-9	SPRING, FEED RETURN	16
					15
1	-	B	690783-5	PLATE, RETAINING	14
					13
					12
1	-	B	1-240644-1	PLATE, REAR SHEAR	11
2	-	C	1-240645-2	SPACER, SHEAR PLATE	10
1	-	B	690784-7	PLATE, FRONT SHEAR	9
1	-	D	240654-3	ANVIL	8
1	-	B	6-240651-7	BLADE, SLUG	7
					6
1	-	C	4-240641-8	SPACER, SLUG BLADE	5
					4
					3
					2
1	-	C	456428-2	CRIMPER, WIRE	1

QTY RECD PER ASSY	PARTS LIST		QTY RECD PER ASSY	PARTS LIST	