

THIS DRAWING IS UNPUBLISHED. RELEASED FOR PUBLICATION 20
 © COPYRIGHT 20 ALL RIGHTS RESERVED.

LOC	DIST	REVISIONS			
P	LTR	DESCRIPTION	DATE	DWN	APVD
AP	-				
	C1	REDRAW BY CAD ECO-12-001612	31JAN2012	NCL	DAO
	C2	REVISED DESIGN ECO-15-010791	27JUL2015	NCL	GOJ

creo
 Creo Parametric 2.0
**DO NOT REUSE
 EXCEPT BY CAD**

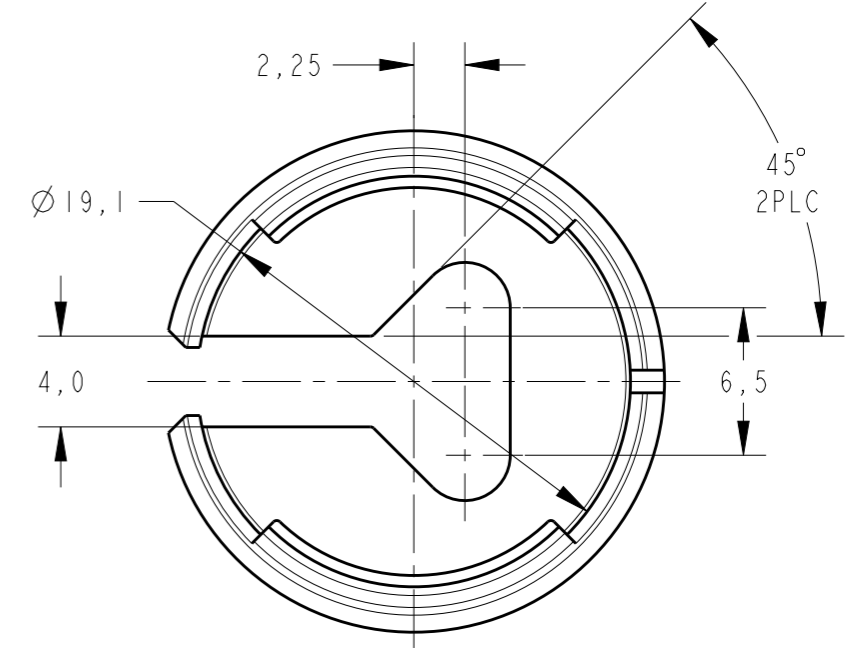
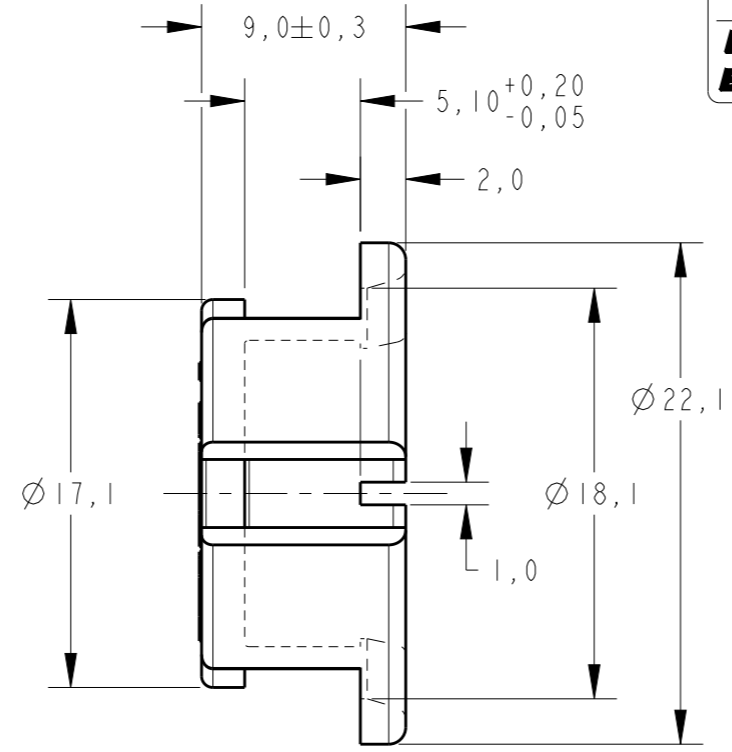
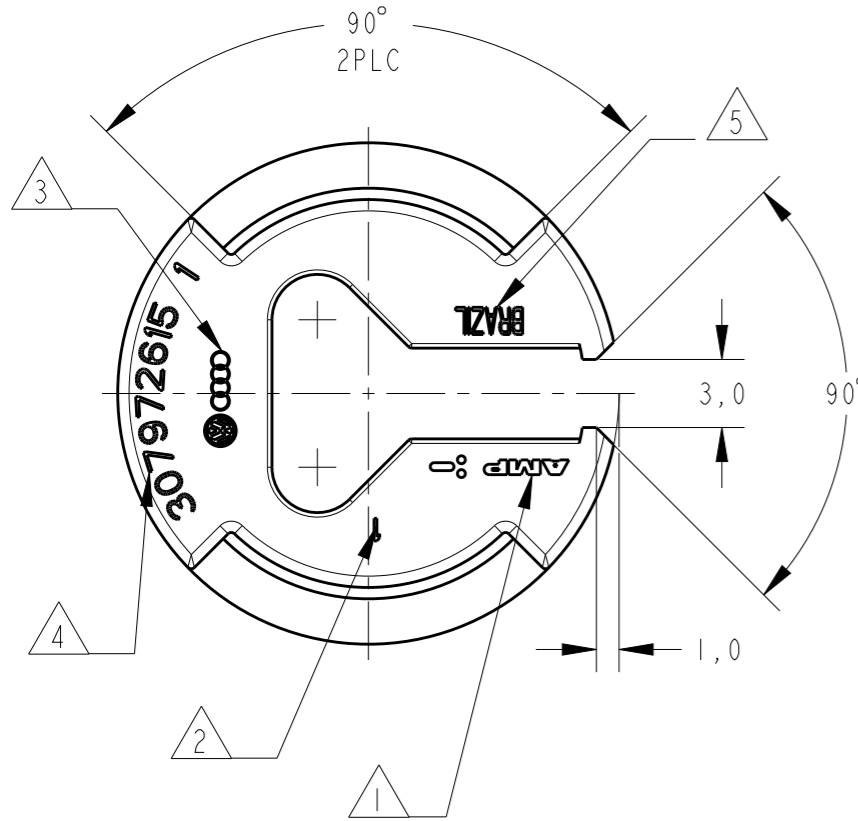

6 - CONTRA PEÇA TE PN 881464
 - COUNTER PART TE PN 881464

7 - MASSA: 1,10gr
 - MASS:

8 - DIMENSÕES NÃO ENCONTRADAS DEVEM SER OBTIDAS DO MODELO CAD 3D DA PEÇA, DEVENDO-SE EMPREGAR O VALOR DA TOLERANCIA CONFORME MOSTRADO NA TABELA DE TOLERANCIA GERAL NESTE DESENHO.

- NOT FOUND DIMENSIONS MUST BE GOTTEN FROM THE PART 3D CAD DATABASE AND MUST BE USED THE VALUE CONFORM SHOWN IN THE TOLERANCE TABLE ON THIS DRAWING.

GRAVAÇÕES MARKINGS	
LOGOTIPO AMP AMP LOGO	1
NÚMERO CAVIDADE CAVITY NUMBER	2
LOGOTIPO CLIENTE CUSTOMER LOGO	3
NÚMERO PEÇA CLIENTE CUSTOMER PART NUMBER	4
PAÍS PRODUTOR MANUFACTURER COUNTRY	5



PERSPECTIVE VIEW
 SCALE 2:1

307 972 615 I	VIOLETA/VIOLET	PA 6.6 + 25% FV	881303 -1
PART NUMBER VW	FINISH	MATERIAL	PART NUMBER
THIS DRAWING IS A CONTROLLED DOCUMENT.		TE Connectivity	
DIMENSIONS: mm 		NAME: SECONDARY LOCKING COVER FOR 3 POSN., SEALING	
TOLERANCES UNLESS OTHERWISE SPECIFIED: 0 PLC ±0,3 1 PLC ±0,3 2 PLC ±0,3 3 PLC ±0,3 4 PLC ±0,3 ANGLES ±1°		PRODUCT SPEC: - APPLICATION SPEC: - WEIGHT: -	
MATERIAL: SEE TABLE	FINISH: SEE TABLE	SIZE: A3	RESTRICTED TO: -
		CAGE CODE: 00779	DRAWING NO: C-881303
		SCALE: 3:1	SHEET 1 OF 1
		REV: C2	