

8 7 6 5 4 3 2 1

REVISIONS					
ZONE	LTR	ECN	DESCRIPTION	DATE	APPROVED
B		27054	NEW RELEASE	1/15/93	[Signature]

C Combine M & CD Dwg

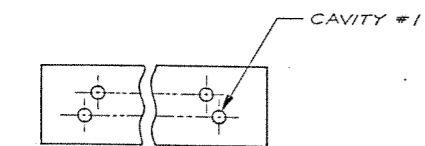
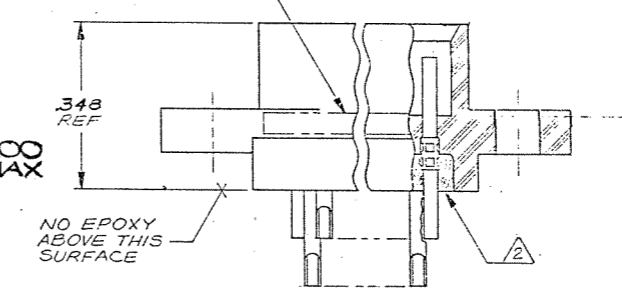
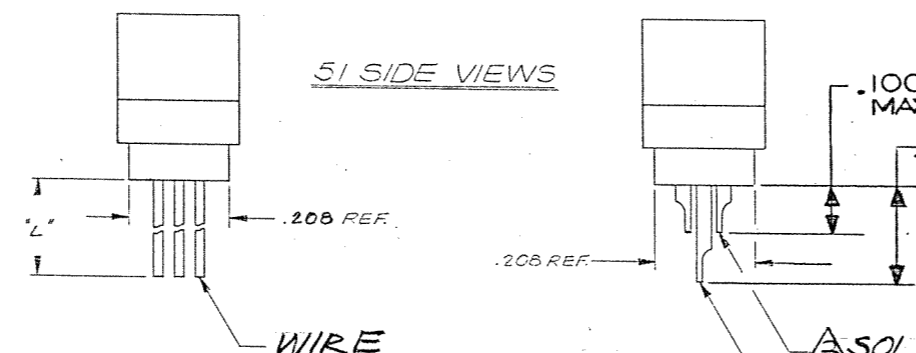
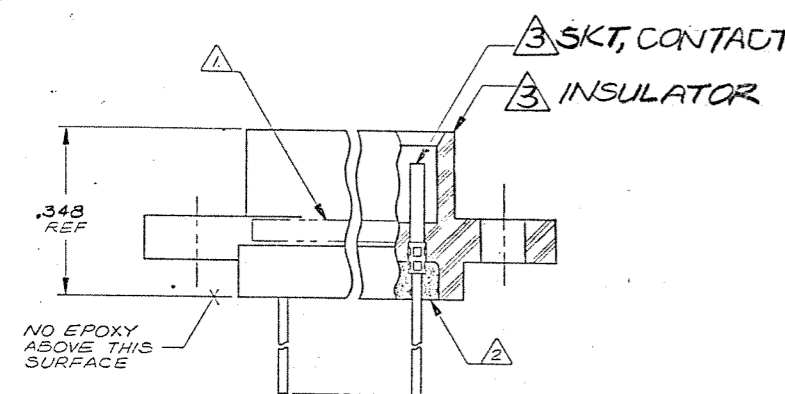
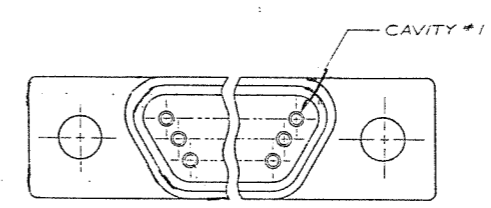
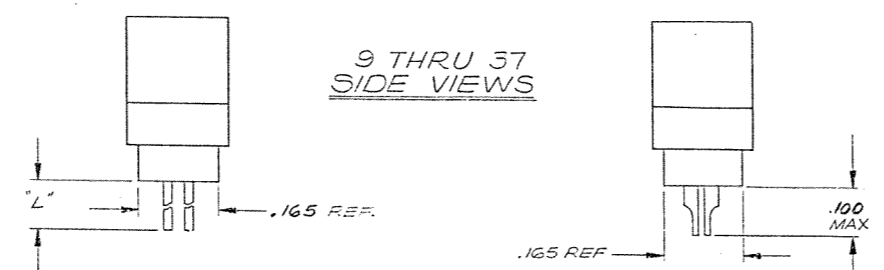
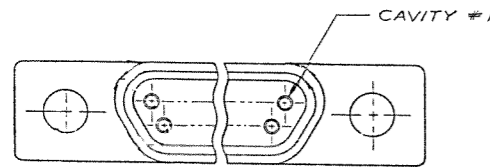

9 THRU 37 CONFIGURATION

3 SOLDER POT-ADAPTER (SHORT)

3 USED ON 51 ONLY SOLDER POT-ADAPTER (LONG)

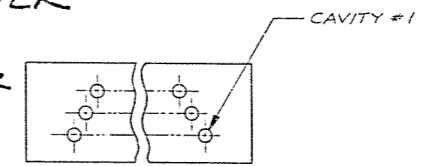

51 CONFIGURATION

(SHOW WITH SOLDER POT TERMINATIONS FOR REFERENCE ONLY. WIRE TERMINATIONS ARE THE SAME CONFIGURATION)

NOTES: UNLESS OTHERWISE SPECIFIED

- 1 MARK "MALCO" OR MALCO LOGO, MILITARY PART NO. (e.g. M53513/07-*) CODE IDENT. NO. & DATE CODE WITH .041 MIN HIGH CHARACTERS IN APPROXIMATE LOCATION SHOWN.
- 2 EPOXY USING HYSOL # 4215 & 3561.

3 SOLDER POT: MATL: BRASS PER QQ-B-626, COMP 360, 1/2 HARD
 FINISH: COPPER ALLOY/GOLD PLATED
 SKT. CONTACT: MATL: COPPER ALLOY/GOLD PLATED
 HOUSING: MATL: (R3) POLYPHENYLENE SULFIDE RYTON RA-04
 (BR-68) PER MIL-M-24519, COLOR BROWN.

Tyco Customer Drawing 1-1532149-5

QTY REQD	CODE IDENT	PART OR IDENTIFYING NO.	NOMENCLATURE OR DESCRIPTION
PARTS LIST			
UNLESS OTHERWISE SPECIFIED DIMENSIONS ARE IN INCHES TOLERANCES ARE: FRACTIONS DECIMALS ANGLES ± .XX ± ± ± .XXX ± ±		CONTRACT NO.	MALCO A MICRODOT COMPANY, INC. 306 PASADENA AVE., SO. PASADENA, CALIF. 91030
MATERIAL		APPROVALS	PROD CODE 824
FINISH		CHECKED [Signature]	DATE 1/15/93
NEXT ASSY USED ON APPLICATION		PR. ENG. [Signature]	7-5-92
DO NOT SCALE DRAWING		APP'D. [Signature]	SIZE CODE IDENT NO. DRAWING NO. D 98278 095-0000-0446
		SCALE NONE SHEET / OF /	

8 7 6 5 4 3 2 1

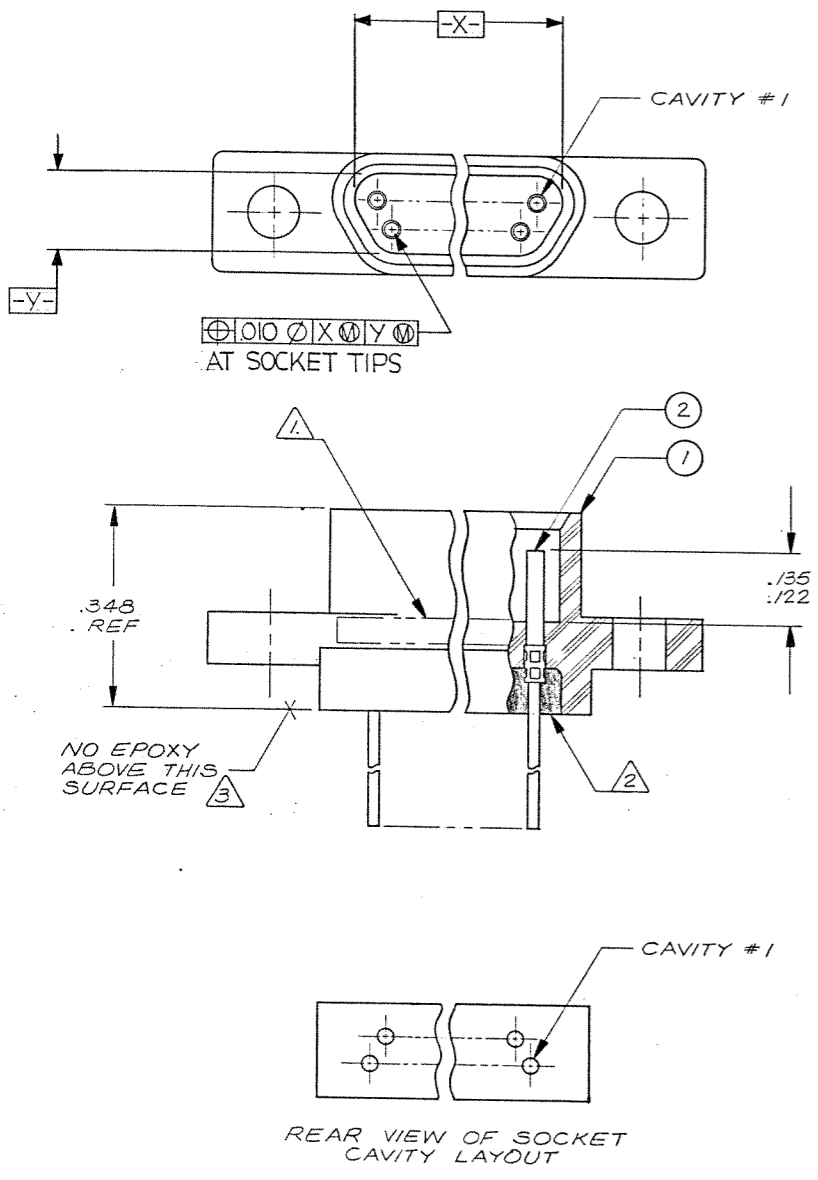

9 THRU 37 CONFIGURATION

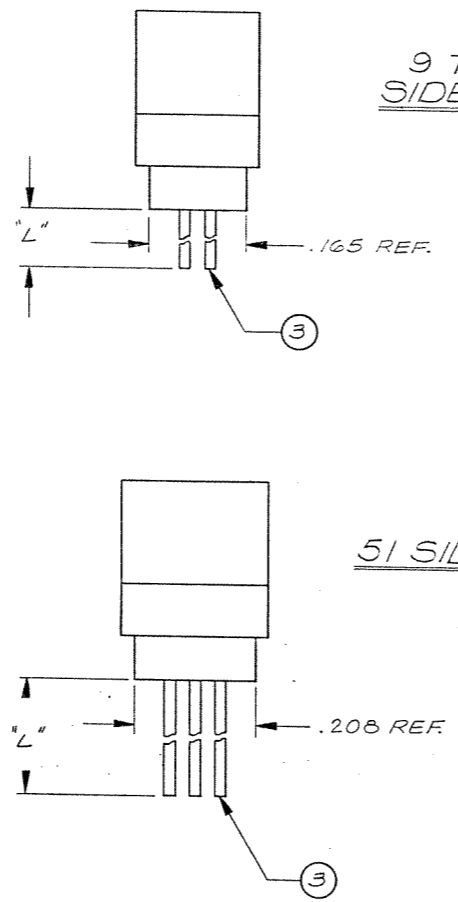

51 SIDE VIEWS

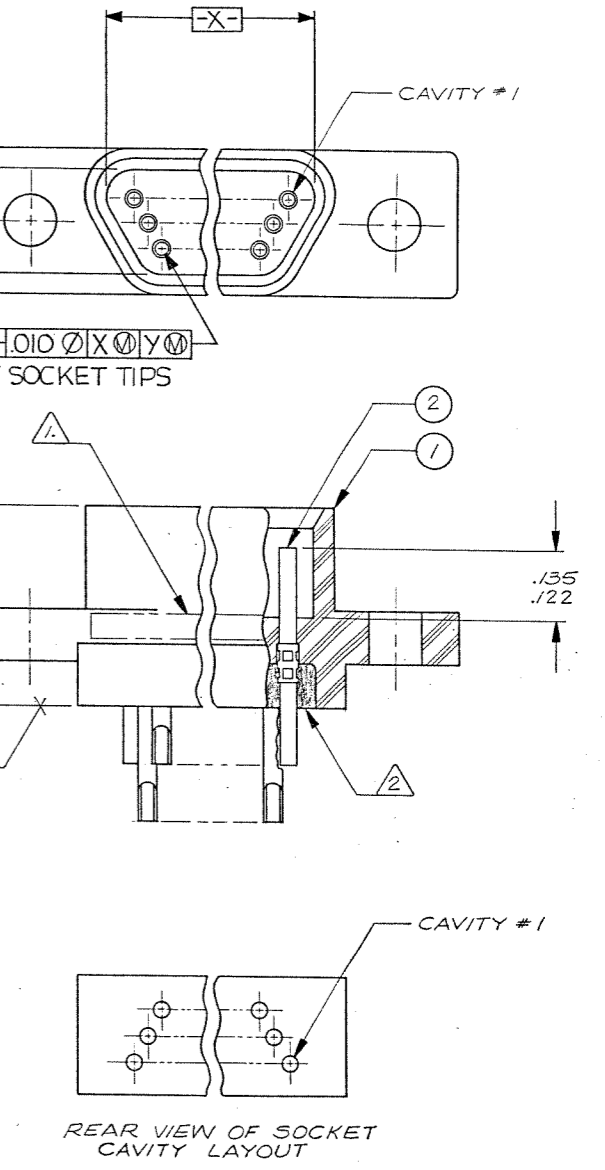

51 CONFIGURATION

(SHOW WITH SOLDER POT TERMINATIONS FOR REFERENCE ONLY. WIRE TERMINATIONS ARE THE SAME CONFIGURATION)

NOTES: UNLESS OTHERWISE SPECIFIED

- 1. MARK "MALCO" OR MALCO LOGO, MILITARY PART NO. (e.g. M83513/07-*), CODE IDENT. NO., & DATE CODE WITH .047 MIN HIGH CHARACTERS IN APPROXIMATE LOCATION SHOWN.
- 2. EPOXY USING HYSOL # 4215 & 3561.
- 3. EPOXY WICKING - UNINSULATED WIRE .050 MAX. INSULATED WIRE UP TO # 25 AWG .125 MAX. INSULATED WIRE # 24 AWG OR LARGER - .200 MAX.
- 4. CRIMP LEADS OR SOLDER POTS INTO CONTACTS PER MEP 302-05.
- 5. NO SCRATCHES SHOWING BASE METAL PERMITTED ON SOLDER POTS.
- 6. CHAMFER ON SOLDER POTS ARE TO BE PARALLEL WITH SIDES OF CONNECTOR WITHIN 10 DEGREES.

Tyco Customer Drawing 1-1532149-5

QTY REQD	CODE IDENT	PART OR IDENTIFYING NO.	NOMENCLATURE OR DESCRIPTION
PARTS LIST			
UNLESS OTHERWISE SPECIFIED DIMENSIONS ARE IN INCHES TOLERANCES ARE:		CONTRACT NO.	
FRACTIONS	DECIMALS	ANGLES	
±	.XX ±	±	
	.XXX ±		
MATERIAL		APPROVALS	DATE
		DRAWN G. SAUER	5-17-82
		CHECKED [Signature]	5-18-82
		PR. ENG. [Signature]	5-18-82
		APPD.	
FINISH		MALCO A MICRODOT COMPANY, INC. 306 PASADENA AVE., SO. PASADENA, CALIF. 91030 RACK & PANEL CONNECTOR, RCPT. MCD PER MIL-C-83513	
NEXT ASSY USED ON		SIZE	CODE IDENT NO. DRAWING NO.
APPLICATION		D	98278 095-0000-0446
DO NOT SCALE DRAWING		SCALE	NONE
		SHEET / OF /	