

Enclosure sizes

EM / ET 205



EM / ET 206



EM / ET 208

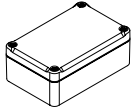

EM / ET 210

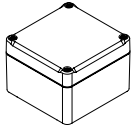

EM / ET 212

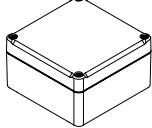

EM / ET 213

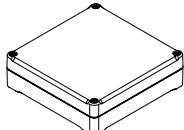

EM / ET 215

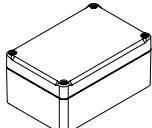

EM / ET 217

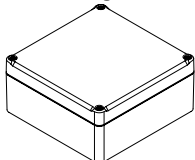

EM / ET 220

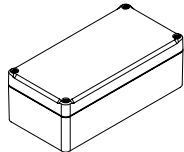

EM / ET 221

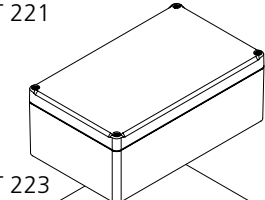

EM / ET 223

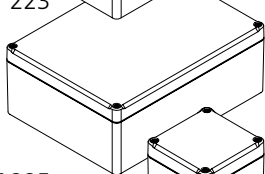

EM / ET 225

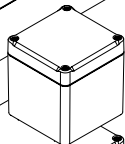

EM / ET 227

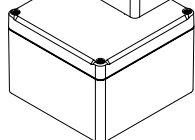

EM / ET 229

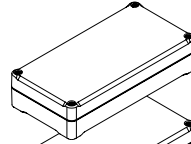

EM / ET 231

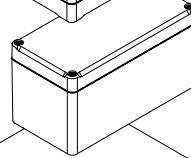

EM / ET 232

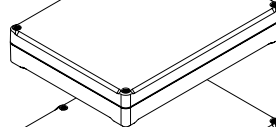

EM / ET 233

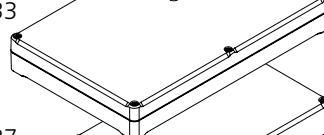

EM / ET 237

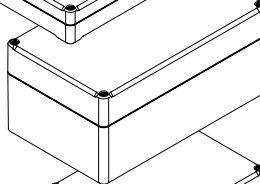

EM / ET 238

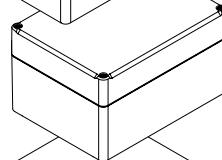

EM / ET 239

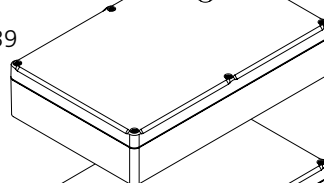

EM / ET 240

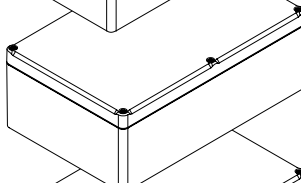

EM / ET 241

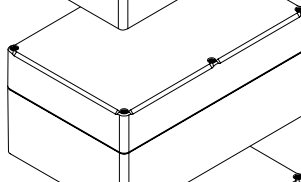

EM / ET 242

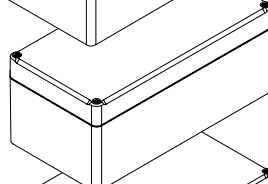

EM / ET 247

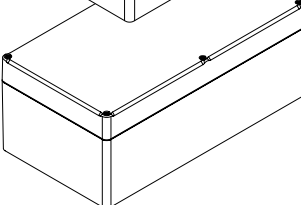

Design types

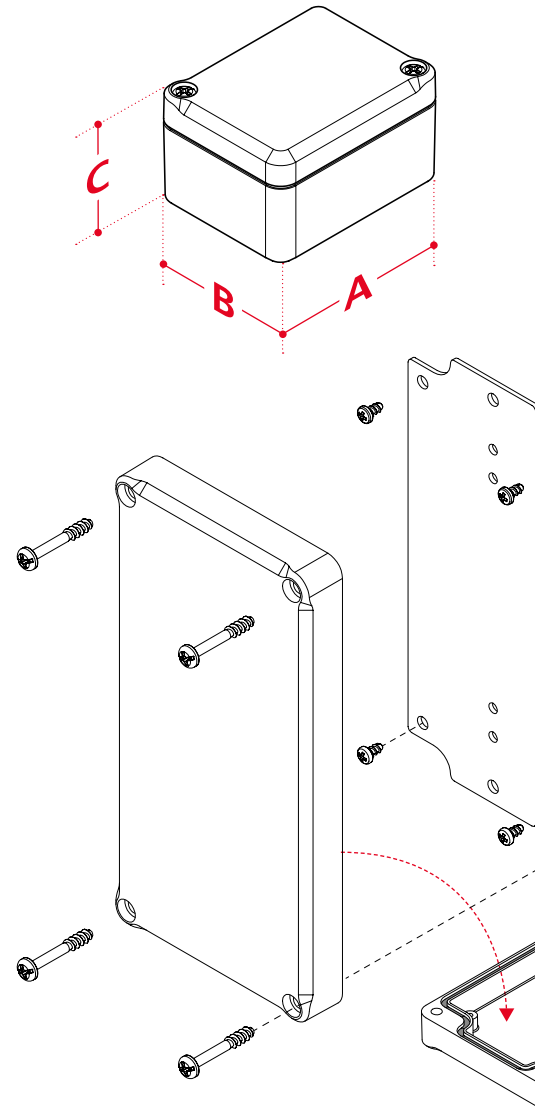

Integrated row of domes

Terminal blocks for direct mounting

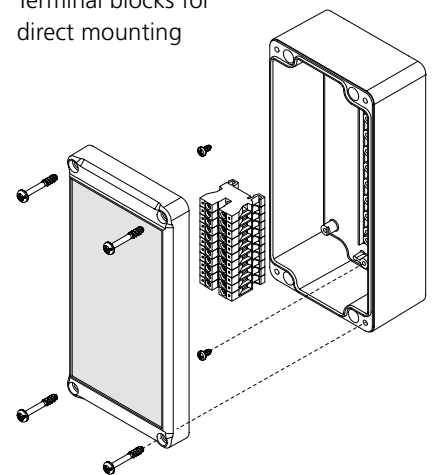



BOPLA

A Phoenix Mecano Company

Euromas II

EM-WL

Screw-on wall brackets as an alternative

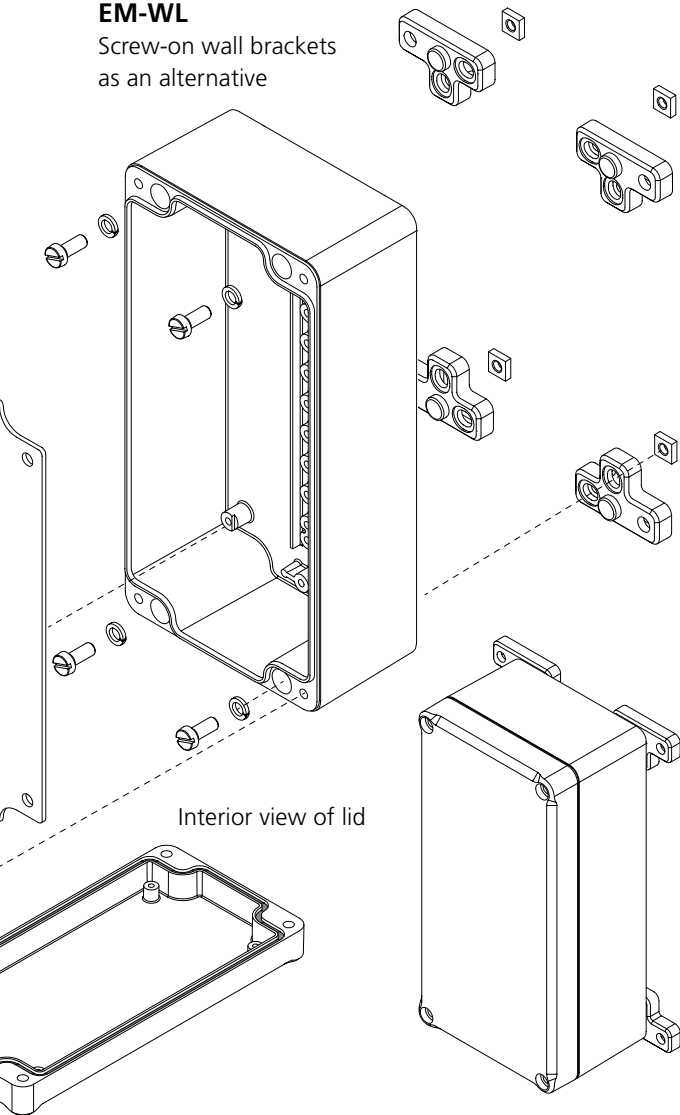

Interior view of lid

Variant EM / ET...LP

with grooves for the vertical mounting of PCBs

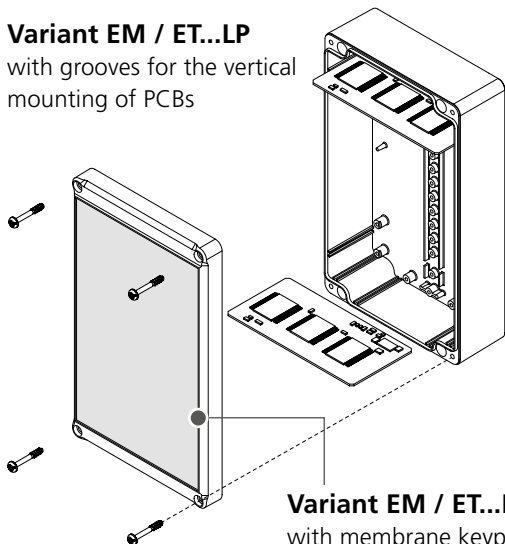

Variant EM / ET...F

with membrane keypad edge

Dimensions

Model	A	B	C	F	LP	F+LP
EM / ET 205	74	50	37	✓		
EM / ET 206	65	50	37	✓		
EM / ET 207	82	60	57		✓	✓
EM / ET 208	98	64	38	✓		
EM / ET 210	82	80	57	✓		
EM / ET 212	100	100	57	✓		
EM / ET 213	122	120	37	✓		
EM / ET 214	200	120	57		✓	✓
EM / ET 215	120	80	57	✓		
EM / ET 217	122	120	57	✓		
EM / ET 218	150	150	57		✓	✓
EM / ET 220	160	80	57	✓		
EM / ET 221	200	120	77	✓		
EM / ET 223	200	150	77	✓		
EM / ET 224	240	80	60		✓	✓
EM / ET 225	82	80	87	✓		
EM / ET 227	122	120	87	✓		
EM / ET 229	160	80	37	✓		
EM / ET 231	160	80	87	✓		
EM / ET 232	200	150	37	✓		
EM / ET 233	250	160	37	✓		
EM / ET 236	240	80	80		✓	✓
EM / ET 237	200	120	92	✓		
EM / ET 238	160	120	92	✓		
EM / ET 239	250	160	57	✓		
EM / ET 240	250	160	92	✓		
EM / ET 241	250	160	122	✓		
EM / ET 242	240	120	102	✓		
EM / ET 247	300	160	120		✓	✓

EM-F / ET-F versions: because of the membrane keypad edge on the lid, dimension C is 1 mm higher.

Accessories



Rubber feet



Screw covers



DIN rails
TH 15, G 32, TH 35



Mast mounting

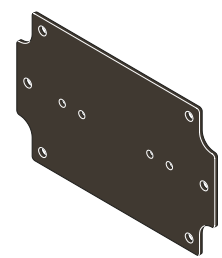

Mounting panels in different versions