

REVISION HISTORY				
ECO	REV	DESCRIPTION	APPROVED	DATE
	2	PRODUCTION	WEI G.	01/24/11

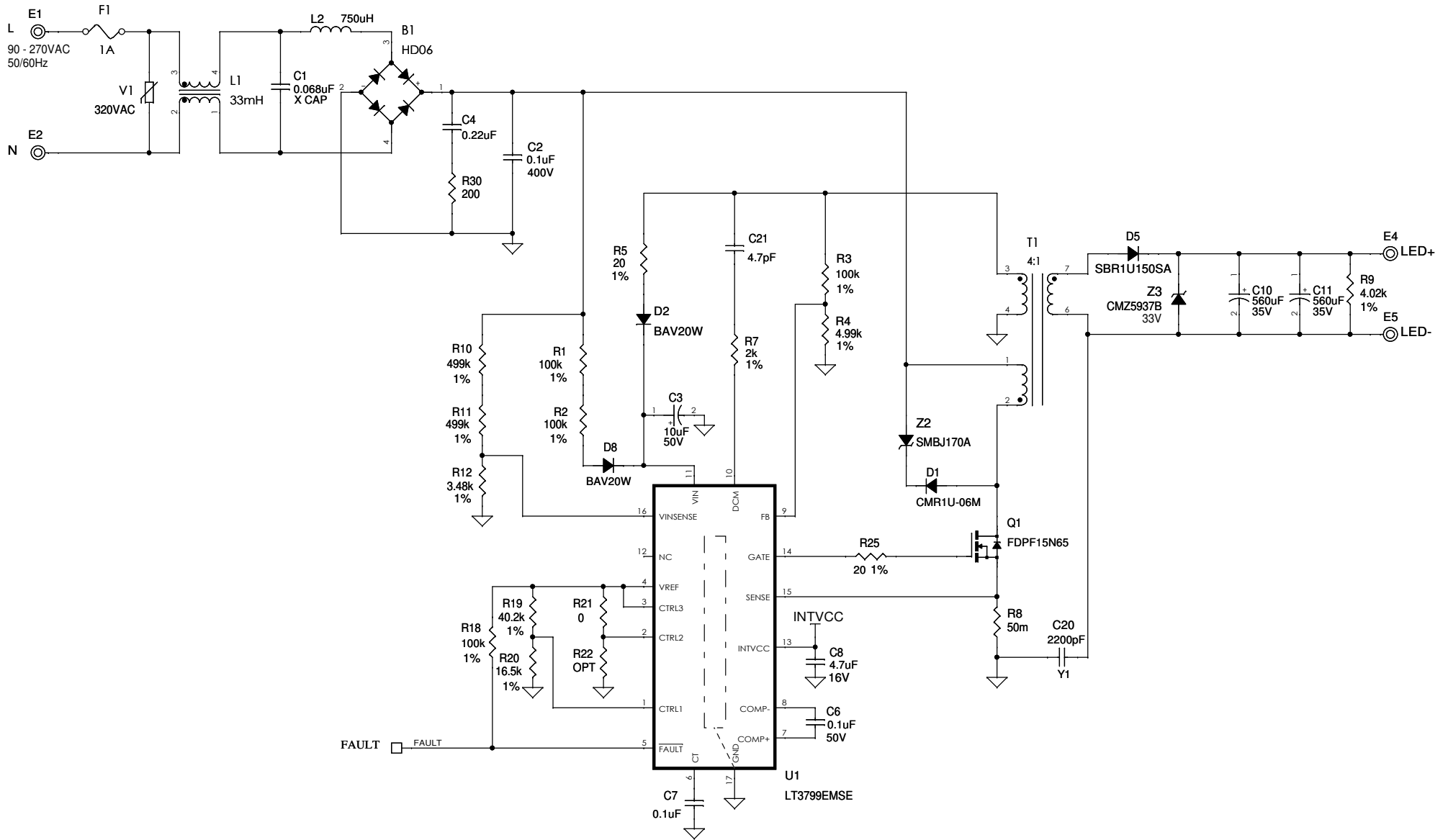

<p><b>CUSTOMER NOTICE</b></p> <p>LINEAR TECHNOLOGY HAS MADE A BEST EFFORT TO DESIGN A CIRCUIT THAT MEETS CUSTOMER-SUPPLIED SPECIFICATIONS; HOWEVER, IT REMAINS THE CUSTOMER'S RESPONSIBILITY TO VERIFY PROPER AND RELIABLE OPERATION IN THE ACTUAL APPLICATION. COMPONENT SUBSTITUTION AND PRINTED CIRCUIT BOARD LAYOUT MAY SIGNIFICANTLY AFFECT CIRCUIT PERFORMANCE OR RELIABILITY. CONTACT LINEAR TECHNOLOGY APPLICATIONS ENGINEERING FOR ASSISTANCE.</p> <p>THIS CIRCUIT IS PROPRIETARY TO LINEAR TECHNOLOGY AND SUPPLIED FOR USE WITH LINEAR TECHNOLOGY PARTS.</p>	<p>CONTRACT NO.</p>	<p><b>LINEAR TECHNOLOGY</b></p> <p>1630 McCarthy Blvd. Milpitas, CA 95035 Phone: (408)432-1900 Fax: (408)434-0507 LTC Confidential-For Customer Use Only</p>
	<p>APPROVALS</p>	
	<p>PCB DES. WEI G. / MI</p>	
	<p>ENG. WEI G.</p>	
	<p>TITLE: SCHEMATIC OFFLINE ISOLATED FLYBACK LED CONTROLLER WITH PFC</p>	
<p>SIZE N/A</p>	<p>IC NO. LT3799EMSE</p>	<p>REV 2</p>
<p>DATE: Wednesday, January 26, 2011</p>	<p>SHEET 1 OF 1</p>	