

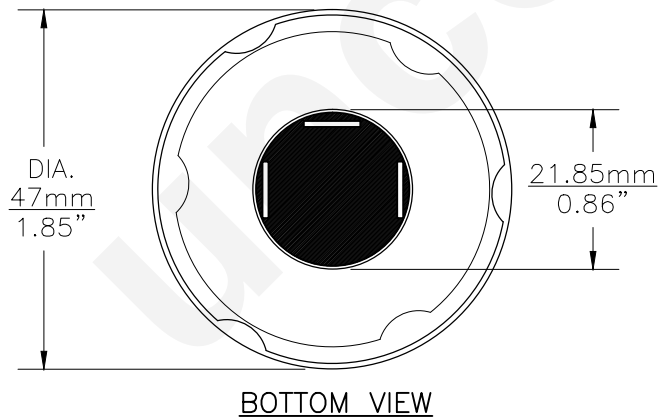

Since 1959

PART NO.	BASE TYPE	DESIGN VOLTS	DESIGN AMPS	MSCD	FILAMENT TYPE	AVERAGE LIFE HOURS	REVISIONS			
							REV #	DESCRIPTION	DATE	APPROVED
6260BA	P45t	12V 12V	5 ±10% 5 ±10%	90±15% 90±15%	C-8 C-2V	100 high 100 low	1	ISSUED	06/29/2015	R.M.

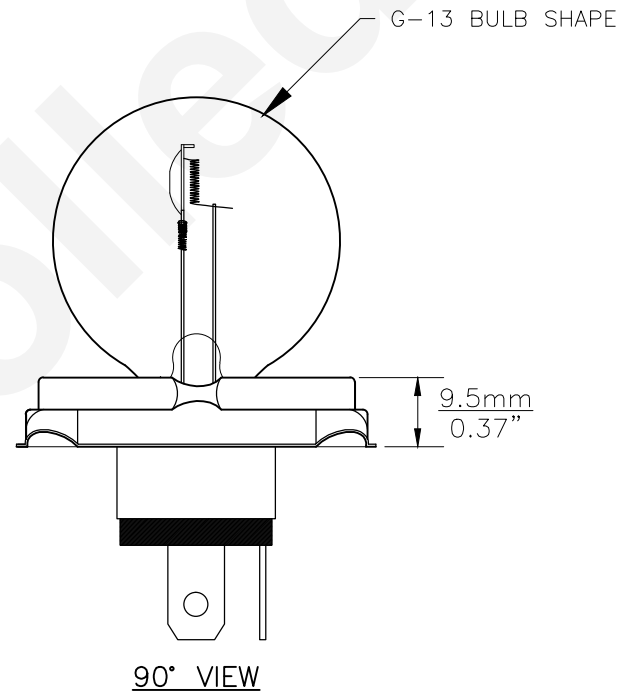
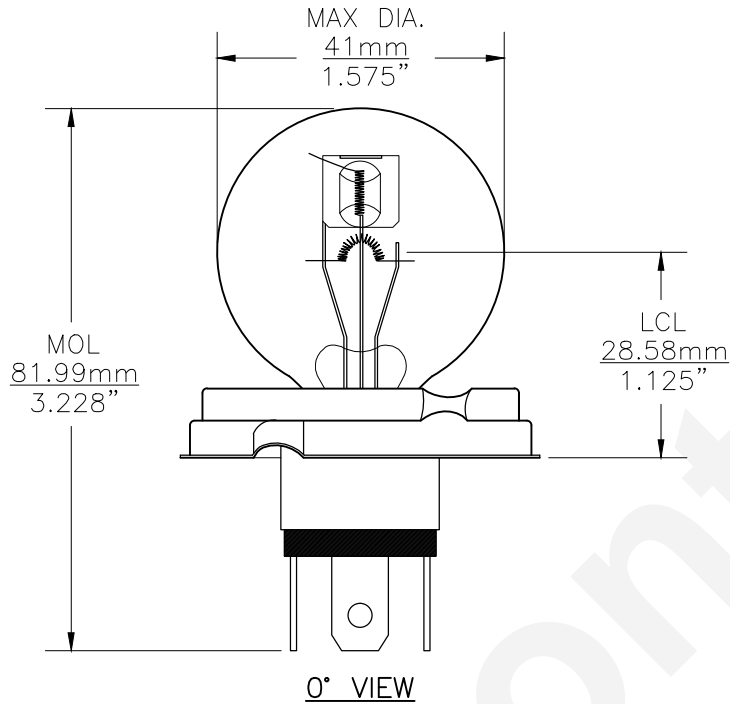

BASE BOTTOM VIEW

UNLESS OTHERWISE SPECIFIED: DIMENSIONS ARE IN INCHES TOLERANCES		CEC INDUSTRIES LTD			
DECIMALS .XX ± .05	ANGULAR ± 0.5°	599 BOND STREET		LINCOLNSHIRE, IL 60069	
FRACTIONAL ± 1/64		TITLE LIGHT BULB NO. 6260BA			
DRAWN ROSE MEDINA	DATE 06/29/2015	SIZE A	FSCM NO.	DWG NO. 6260BA	REV 1
CHECKED		SCALE	PLOT SCALE	SHEET 1 OF 1	
MATERIAL	FILE 6260BA.pdf	DRAWING NOT TO SCALE			

