

EasyPIC PRO v8

DEVELOPMENT BOARD

SCHEMATIC

POWER/DEBUG

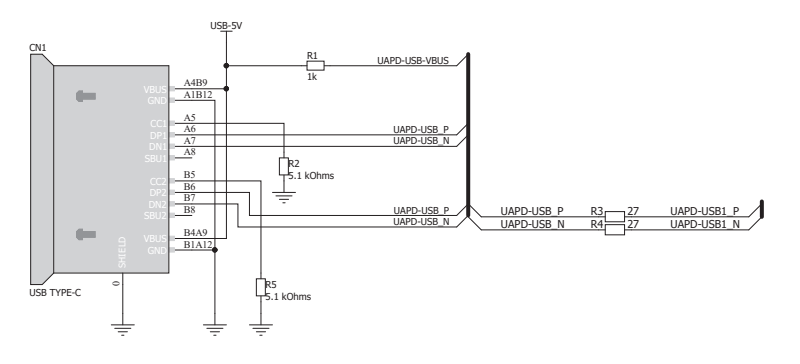

POWER BATT

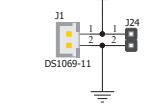

POWER 12VDC

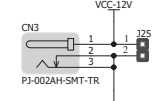

DBG SEL

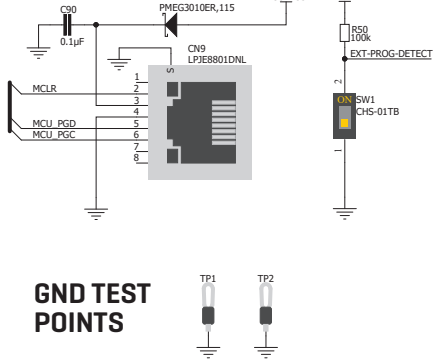

GND TEST POINTS

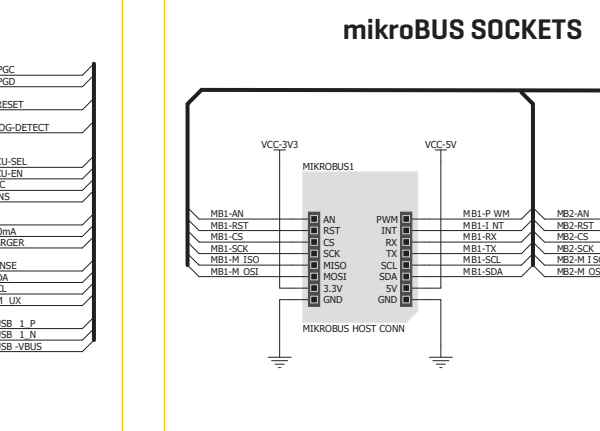
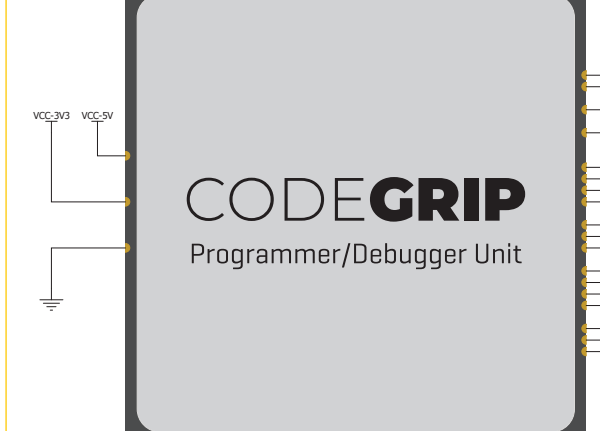

USB UART

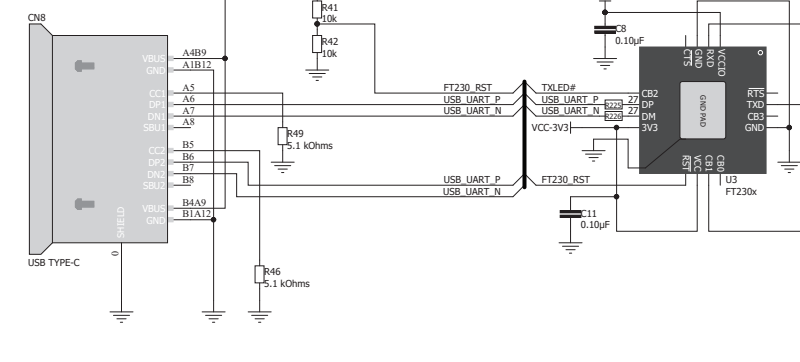

TFT CONNECTOR

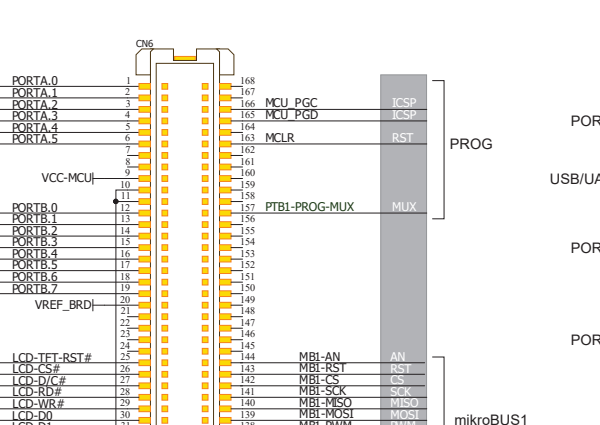
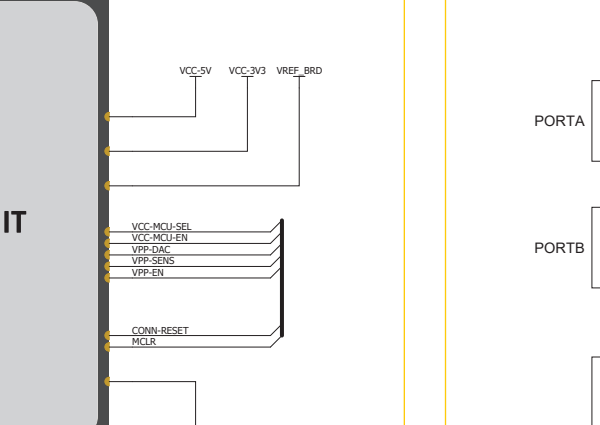
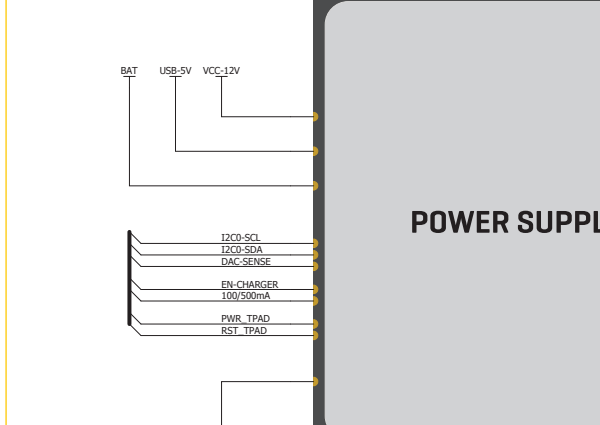
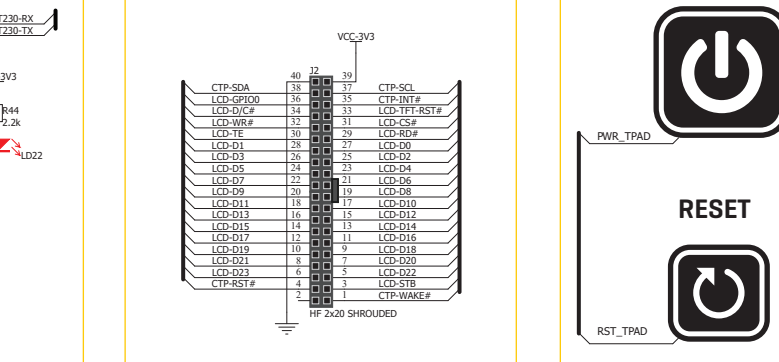

USB DEVICE

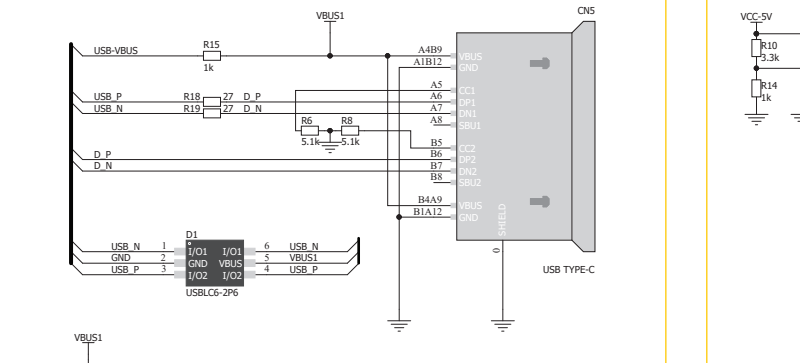

LCD

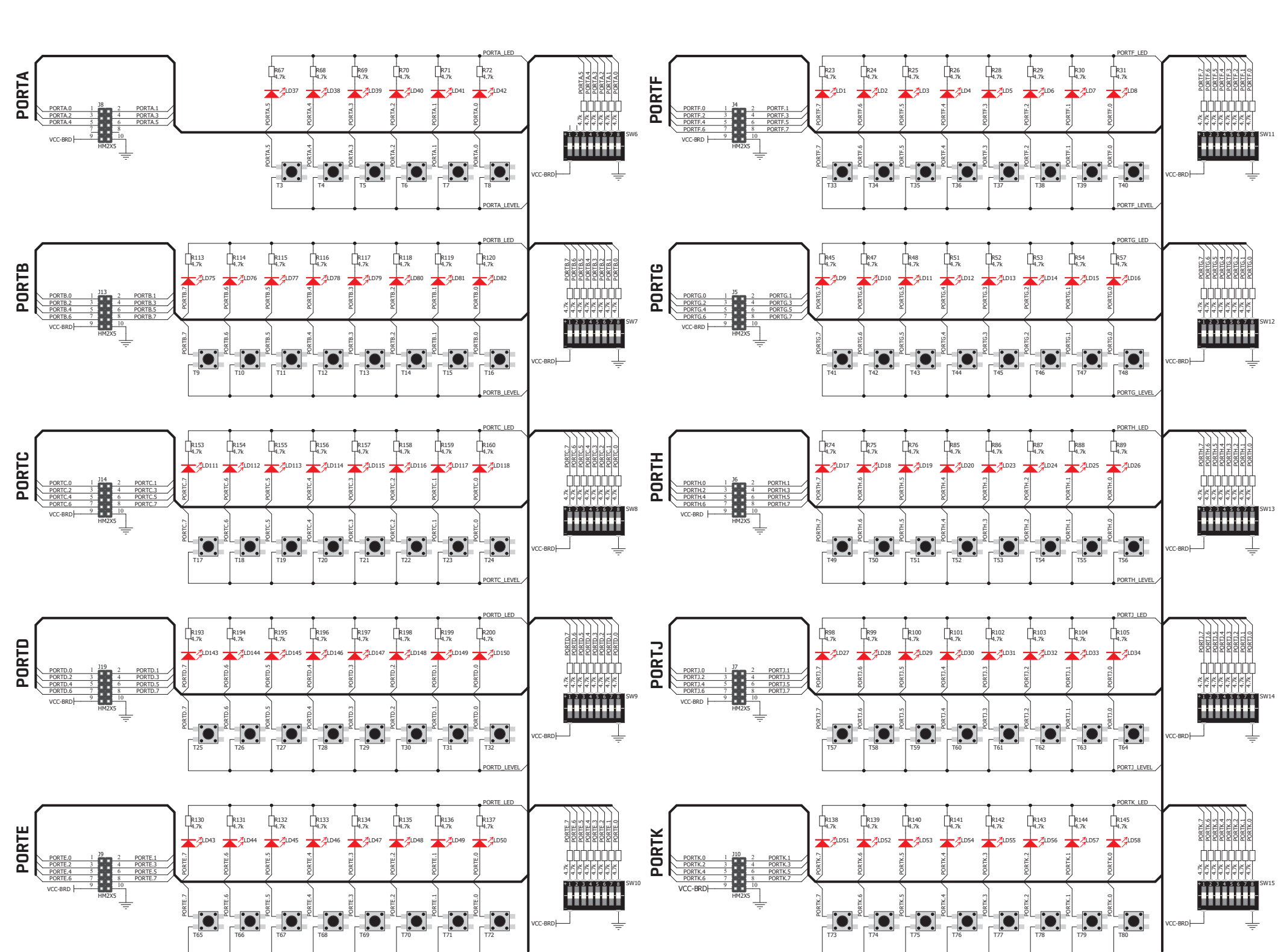
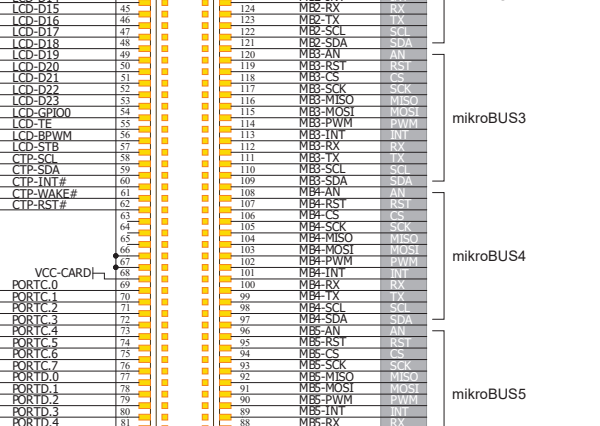
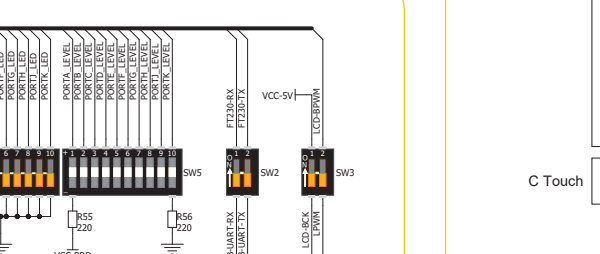
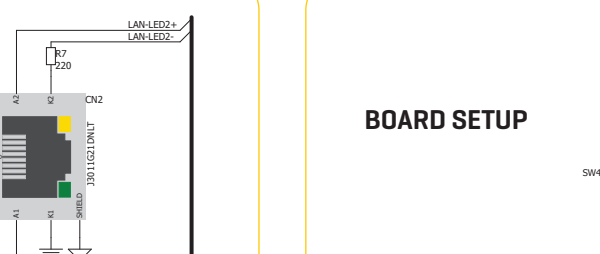
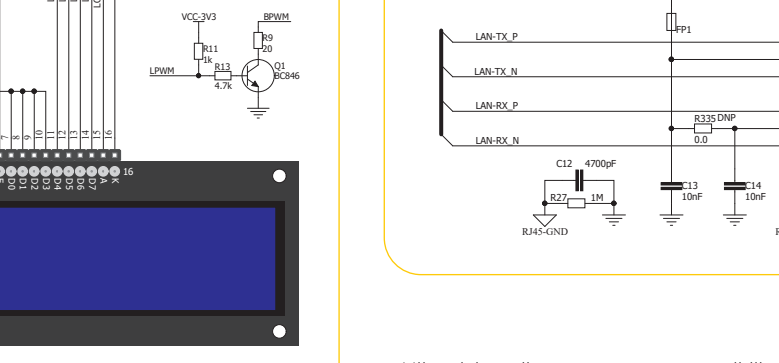

Mikroelektronika assumes no responsibility or liability for any errors or inaccuracies that may appear in the present document. Specification and information contained in the present schematic are subject to change at any time without notice. Copyright ©2020 Mikroelektronika. All rights reserved.