

PART NUMBER	REVISION	DESCRIPTION	FEED TYPE
2150511-1	C	FINE CRIMP HEIGHT ADJUST	MECHANICAL
2150511-2	C	FINE CRIMP HEIGHT ADJUST	PNEUMATIC
7-2150511-1	C	MECHANICAL AND CRIMP TOOLING KIT	MECHANICAL
7-2150511-2	C	PNEUMATIC AND CRIMP TOOLING KIT	PNEUMATIC
7-2150511-7	A	CRIMP TOOLING KIT	-

ATLANTIC VERSION TERMINATOR INTERFACE ADAPTER

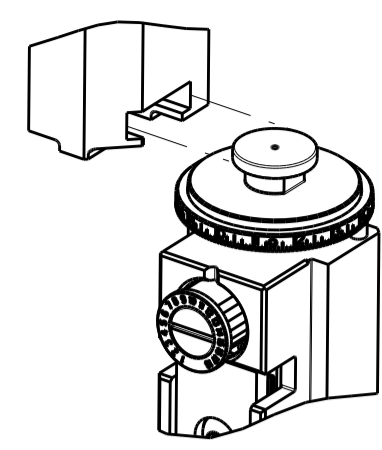

APPLICATOR DATA		
CRIMP	SIZE	TYPE
WIRE	1.52 mm [.060]	F
INSUL	2.79 mm [.110]	O
APPL INSTRUCTIONS 408-35042		

TERMINAL DATA: TE TERMINAL		TE CRIMP SPECIFICATION	
TERMINAL NAME: .250 SERIES RECEPTACLE WITHOUT LATCH			
WIRE STRIP LENGTH	INSULATION DIAMETER RANGE		
4.00-4.75 mm [.157-.187 IN]	Ø1.50-2.20 mm [.059-.087 IN]		
TERMINAL APPLICATION SPECIFICATION	114-5052		
TERMINALS APPLIED			
TE TERMINAL	TE TERMINAL	TE TERMINAL	TE TERMINAL
170384-1	170384-7	6-170384-1	7-170384-7
170384-2	170384-9	7-170384-1	

WIRE SIZE	CRIMP HEIGHT mm [INCH]	CRIMP HEIGHT REFERENCE SETTING
0.50mm2	1.20 +/- 0.05 [.047 +/- .002]	8.7
0.30mm2	1.10 +/- 0.05 [.043 +/- .002]	9.6

- RECOMMENDED SPARE PARTS
- REFER TO SUPPLIED INSTRUCTION SHEET FOR CLEANING, LUBRICATION AND STORAGE OF APPLICATOR.
- APPLY PART NUMBER 1-23419-5 LOCTITE TO THREADS OF ITEMS 180. APPLY PART NUMBER 2-23419-6 LOCTITE TO THREADS OF ITEM 242.
- CRIMP HEIGHT REFERENCE SETTING WAS THE SETTING USED WHEN THE APPLICATOR WAS QUALIFIED AT THE FACTORY. ADJUSTMENT MAY BE NECESSARY WHEN RUNNING APPLICATOR IN THE FIELD.
- UNLESS SPECIFIED OTHERWISE TORQUE VALUES SHALL BE USED PER DOCUMENT, 101-35000.

***WARNING**
ON INSTALLATION, SET WIRE DISC TO CRIMP HEIGHT REFERENCE SETTING FOR LARGEST WIRE SIZE. CRIMP HEIGHT REFERENCE SETTINGS GREATER THAN THE VALUE SHOWN MAY CAUSE DAMAGE TO THE CRIMP TOOLING, REFER TO THE INSTRUCTION SHEET FOR PROPER SETUP AND ADJUSTMENTS.

ATLANTIC VERSION
Shown on sheets 1 of 4 & 2 of 4
(Pacific version shown on sheets 3 of 4 & 4 of 4)

LOC	DIST	REVISIONS					
A	66	P	LTN	DESCRIPTION	DATE	OWN	APVD
		1		DEVELOPMENT	07JAN2015	JH	UG
		A		RELEASED	03FEB2015	JH	GB
		B		ECR-20-009104	25JUN2020	JAH	RK
		C		ECR-20-011870	21AUG2020	FJ	RK

-	1	-	1	-	2119641-1	FEED CAM, AIR FEED	248	
-	1	1	1	1	2119082-4	CAM, SNAIL, INSULATION ADJUSTMENT	244	
-	1	1	1	1	2079764-1	WASHER, WAVE SPRING, CREST-TO-CREST	243	
3	-	1	1	1	2119083-1	RETAINER, INSULATION DIAL	242	
-	-	1	-	1	2119580-1	MECHANICAL FEED ASSEMBLY	239	
-	1	-	1	-	2844940-3	AIR FEED MODULE	238	
-	1	1	1	1	1-18028-0	WASHER, FLAT, REG M8	192	
3	-	1	1	1	1-1752354-0	STANDOFF, HOLD-DOWN	180	
-	1	1	1	1	6-993111-6	PIN, SLOTTED SPRING 3.0 X 14.0	177	
-	1	1	1	1	8-22280-7	SPRING, COMPRESSION	176	
-	1	1	1	1	1752353-2	GUIDE PIN, HOLDDOWN	175	
-	1	1	1	1	1901680-2	GUIDE PIN, HOLDDOWN	174	
-	REF	REF	REF	REF	994970-2	COUNTER, MAGNETIC	164	
-	1	1	1	1	455888-4	SPACER, CRIMPER	82	
-	1	1	1	1	1803607-4	DOCUMENTATION PACKAGE	71	
-	2	2	2	2	2-18032-2	SCR, SET, FLT PNT, M3 X 10.0	70	
-	1	1	1	1	2119740-1	TAG, IDENTIFICATION	67	
-	2	2	2	2	2168078-1	SCREW, DRIVE, RH, RoHS, 2 x .188	66	
-	1	1	1	1	1901681-1	HOLDDOWN, TERMINAL	65	
-	2	2	2	2	2168400-5	SHCS, LOW HEAD, RoHS, M4 X 20	64	
-	1	1	1	1	2168083-2	SCR, SKT HD CAP, RoHS, M4 X 8.0	60	
-	1	1	1	1	5-18022-5	SCR, HEX HD CAP, M4 X 6.0	59	
-	-	1	-	1	2063961-3	FEED FINGER	58	
-	3	3	3	3	2168400-4	SHCS, LOW HEAD, RoHS, M4 X 8	57	
-	2	2	2	2	2168083-3	SCR, SKT HD CAP, RoHS, M4 X 12.0	56	
-	2	2	2	2	5018030-1	NUT, HEX, REG, RoHS, M3	54	
-	2	2	2	2	986965-8	NUT, LOCK, HEX, TORQUE (M4)	53	
-	1	1	1	1	1-5018030-0	NUT, HEX, REG, RoHS, M3.5	52	
-	1	-	1	-	2063961-3	FEED FINGER	51	
-	1	2	1	2	18023-9	SCR, SKT HD CAP M4 X 6.0	49	
-	-	1	-	1	2119652-1	FEED CAM, PRE FEED	48	
-	-	1	-	1	2119653-1	FEED CAM, POST FEED	47	
-	1	1	1	1	2119655-5	APPLICATOR BASIC ASSEMBLY, EF	46	
-	1	1	1	1	1803517-1	RAM ASSEMBLY, EF ATLANTIC	44	
-	1	1	1	1	1803602-1	SCR, BHSC, RoHS (M8 X 25)	41	
-	7	7	7	7	1-18028-2	WASHER, FLAT, REG M4	33	
-	2	2	2	2	2168083-9	SCR, SKT HD CAP, RoHS, M4 X 20	31	
-	2	2	2	2	1-2168083-0	SCR, SKT HD CAP, RoHS, M4 X 10	29	
-	1	1	1	1	240639-1	STRIPPER (MACHINING)	27	
-	2	2	2	2	1-2168083-5	SCR, SKT HD CAP, RoHS, M4 X 30	25	
-	1	1	1	1	1752371-5	PLATE, STRIP GUIDE	24	
-	1	1	1	1	240825-7	PLATE, STRIP HOLD DOWN	23	
-	2	2	2	2	2-22281-3	SPRING, COMPRESSION	22	
-	1	1	1	1	1803292-4	DRAG	20	
-	2	2	2	2	1901259-5	GUIDE, LOWER STRIP	18	
-	4	4	4	4	1-2079383-1	SCR, BHSC, RoHS (M6 X 12)	17	
-	1	1	1	1	3-240641-0	SPACER	16	
-	1	1	1	1	1752360-1	SPACER, HOLD-DOWN	13	
1	-	1	1	1	240644-1	PLATE, REAR SHEAR	11	
-	-	-	-	-	-	-	10	
1	-	1	1	1	690482-4	PLATE, FRONT SHEAR	9	
1	2	2	1	1	7-1803001-0	ANVIL, COMBINATION, END FEED	8	
1	-	1	1	1	1-2217206-0	BLADE, SLUG	7	
-	-	-	-	-	-	-	6	
-	1	1	1	1	240641-5	SPACER	5	
-	1	1	1	1	3-238011-1	BLOCK, CRIMPER SPACER	4	
1	1	2	1	1	8-1633965-3	CRIMPER, INSULATION O PREMIUM	3	
-	1	1	1	1	455888-8	SPACER, CRIMPER	2	
1	2	2	1	1	9-1633609-3	CRIMPER, WIRE	1	
-	77	72	71	2	-1	PART NO	DESCRIPTION	ITEM NO

DIMENSIONS:		TOLERANCES UNLESS OTHERWISE SPECIFIED:		DRAWN		CHK		APVD		NAME	
mm	0 PLC ±	1 PLC ±	2 PLC ±	3 PLC ±	4 PLC ±	J. HOU	L. ZHANG	J. GUO	J. HOU	01JAN2015	01JAN2015
MATERIAL		FINISH		WEIGHT		SCALE		SHEET		REV	
						A 00779		1		C	

LOC	DIST	REV	DATE	BY	APPV
A	66				
REVISIONS			DESCRIPTION	DATE	BY
			SEE SHEET 1		

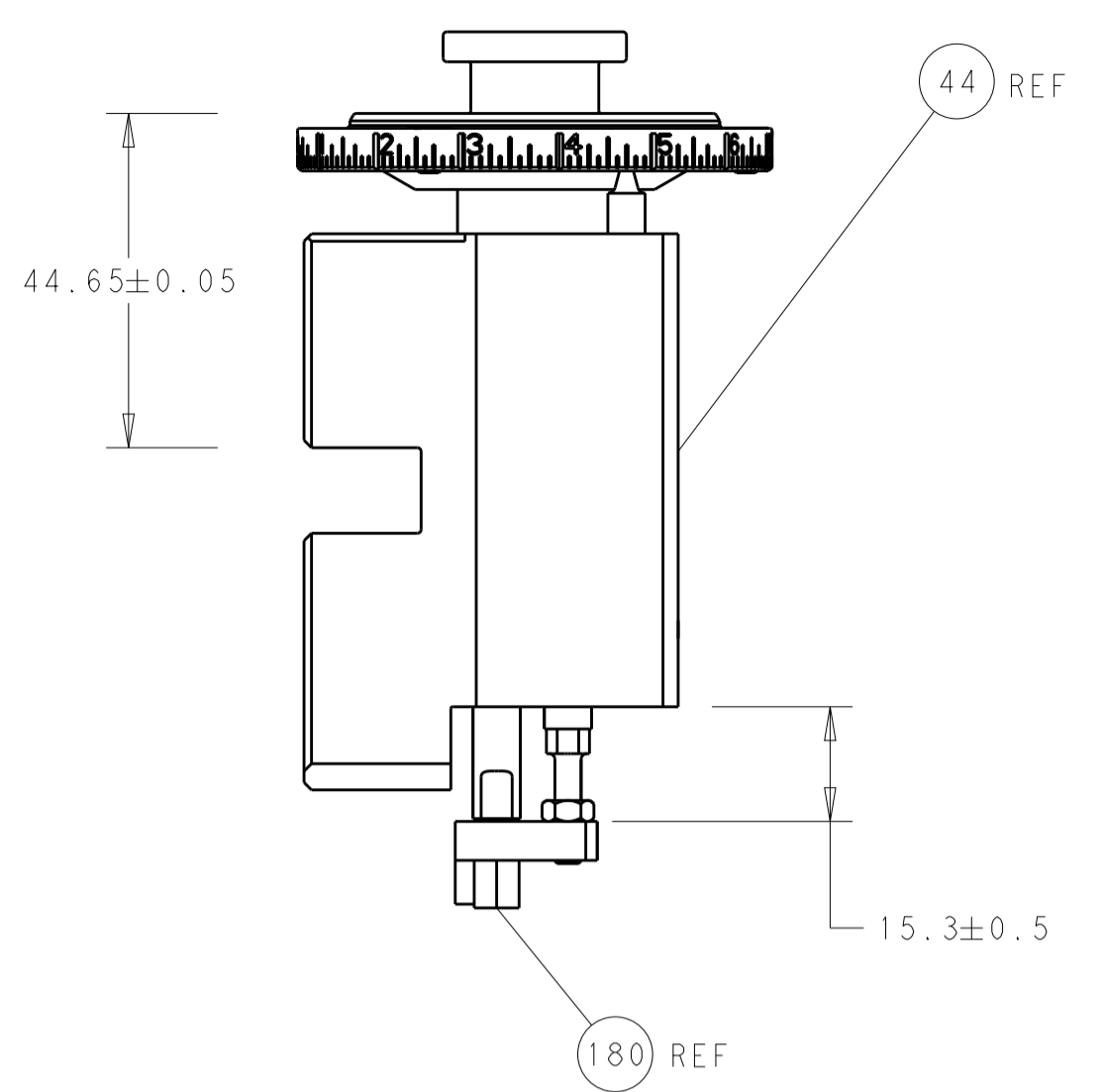

RAM AND HOLDDOWN SET-UP

FEED TYPE
MECHANICAL

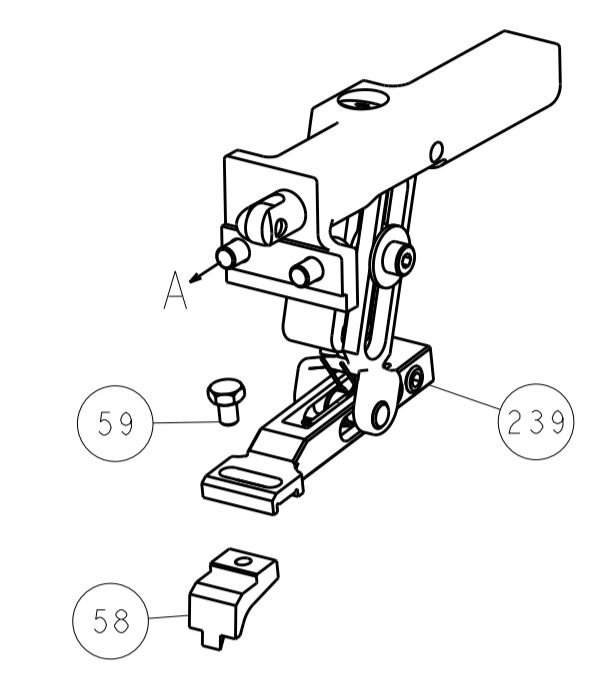

PNEUMATIC

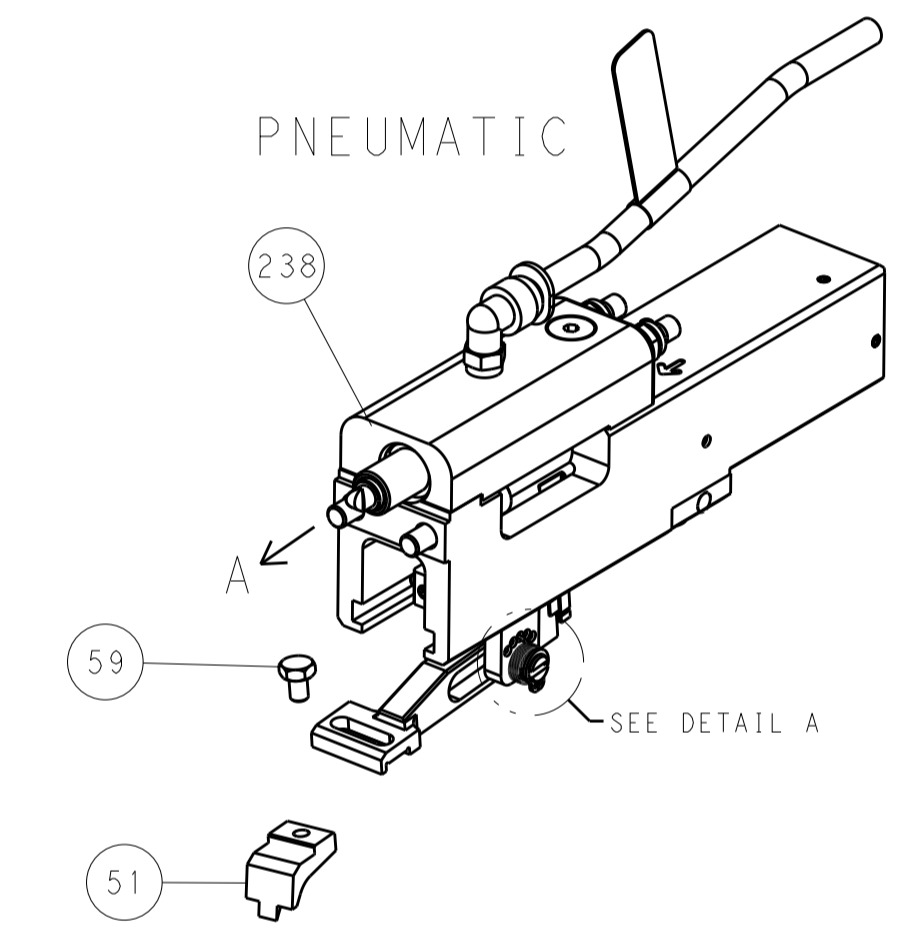

FEED SPRING
SETTING POSITION

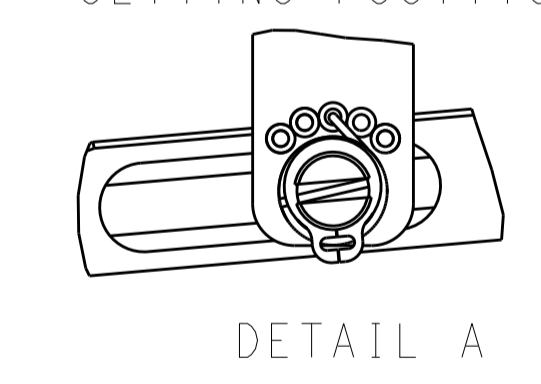

CAM POSITIONS

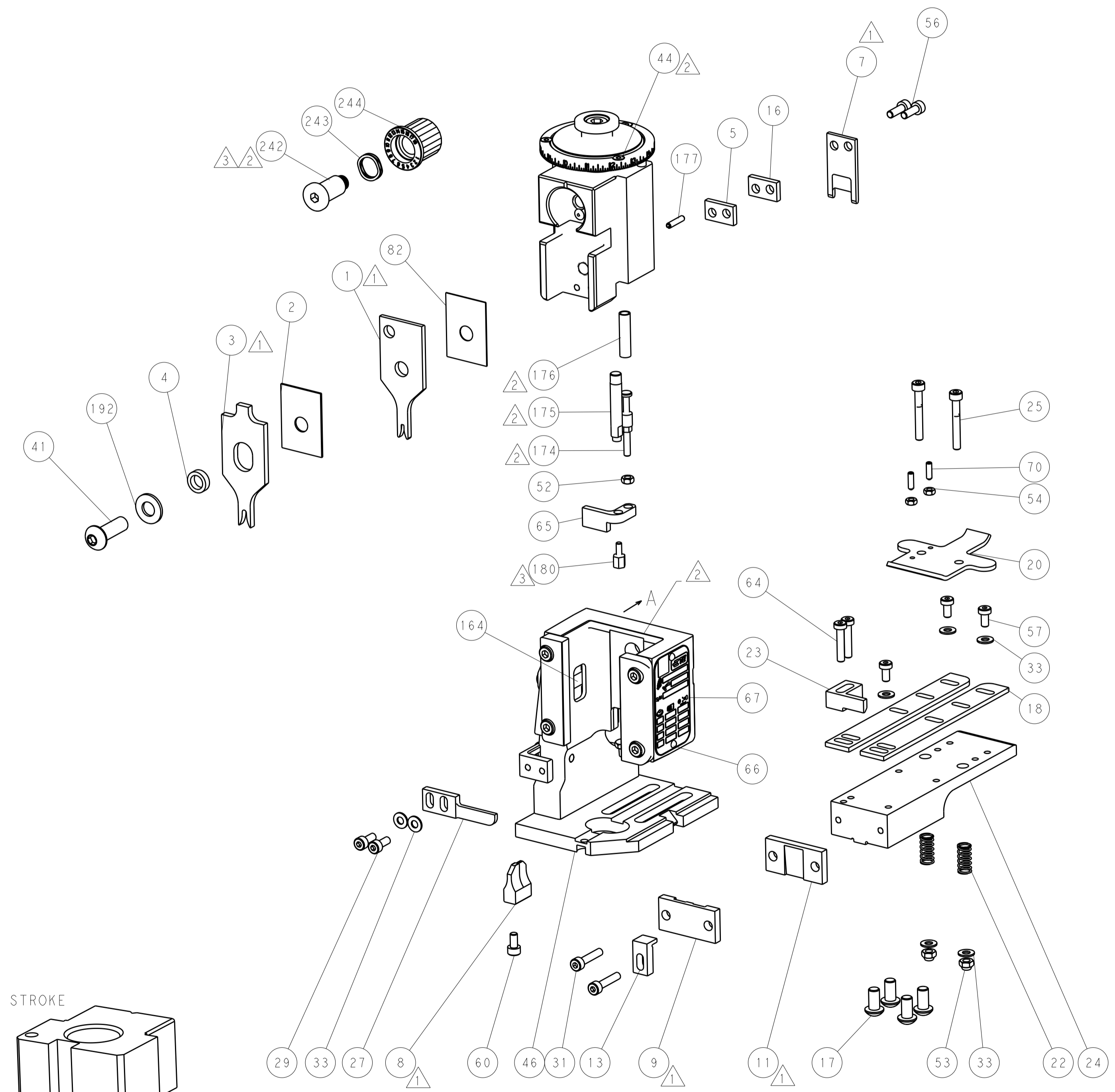
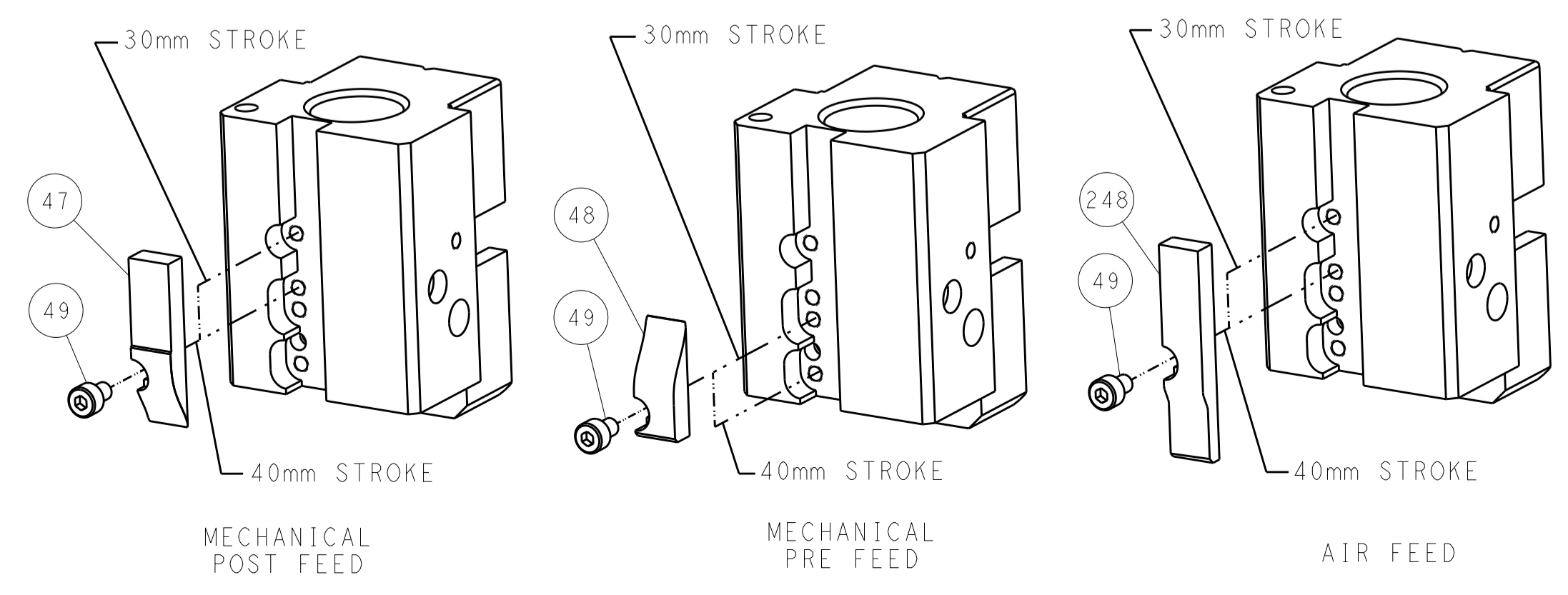

ATLANTIC VERSION
 Shown on sheets 1 of 4 & 2 of 4
 (Pacific version shown on sheets 3 of 4 & 4 of 4)

DIMENSIONS:		TOLERANCES UNLESS OTHERWISE SPECIFIED:		DWG: J. HOU 01JAN2015		TE Connectivity	
mm		0 PLC ±		CHK: L. ZHANG 01JAN2015		Harrisburg, PA 17105-3608	
Ø		1 PLC ±		APVD: H. GUO 01JAN2015		NAME: Ocean End Feed Applicator	
H		2 PLC ±		PRODUCT SPEC		SIZE: CAGE CODE: DRAWING NO:	
D		3 PLC ±		APPLICATION SPEC		RESTRICTED TO:	
R		4 PLC ±		WEIGHT		A1 00779 ©=2150511	
ANGLES		FINISH		Customer Accessible Production Drawing		SCALE: 1:1 SHEET 2 OF 4 REV C	

PART NUMBER	REVISION	DESCRIPTION	FEED TYPE
2-2150511-1	C	FINE CRIMP HEIGHT ADJUST	MECHANICAL
2-2150511-2	C	FINE CRIMP HEIGHT ADJUST	PNEUMATIC
7-2150511-7	A	CRIMP TOOLING KIT	-

PACIFIC VERSION TERMINATOR
 INTERFACE ADAPTER

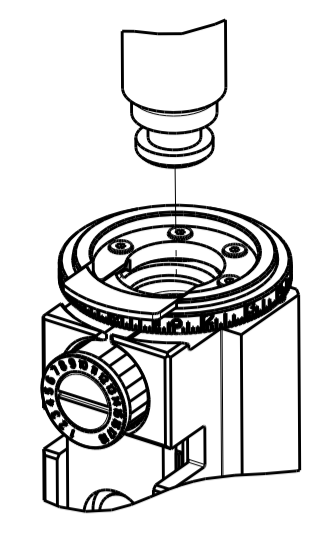

APPLICATOR DATA		
CRIMP	SIZE	TYPE
WIRE	1.52 mm [.060]	F
INSUL	2.79 mm [.110]	Q
APPL INSTRUCTIONS 408-35042		

TERMINAL DATA: TE TERMINAL		TE CRIMP SPECIFICATION	
TERMINAL NAME: .250 SERIES RECEPTACLE WITHOUT LATCH			
WIRE STRIP LENGTH 4.00-4.75 mm [.157-.187 IN]		INSULATION DIAMETER RANGE 1.50-2.20 mm [.059-.087 IN]	
TERMINAL APPLICATION SPECIFICATION 114-5052			
TERMINALS APPLIED			
TE TERMINAL	TE TERMINAL	TE TERMINAL	TE TERMINAL
170384-1	170384-7	6-170384-1	7-170384-7
170384-2	170384-9	7-170384-1	

WIRE SIZE	CRIMP HEIGHT mm [INCH]	CRIMP HEIGHT REFERENCE SETTING
0.50mm2	1.20+/-0.05 [.047+/-0.002]	8.7
0.30mm2	1.10+/-0.05 [.043+/-0.002]	9.6

- RECOMMENDED SPARE PARTS
- REFER TO SUPPLIED INSTRUCTION SHEET FOR CLEANING, LUBRICATION AND STORAGE OF APPLICATOR.
- APPLY PART NUMBER 1-23419-5 LOCTITE TO THREADS OF ITEMS 180. APPLY PART NUMBER 2-23419-6 LOCTITE TO THREADS OF ITEM 242.
- CRIMP HEIGHT REFERENCE SETTING WAS THE SETTING USED WHEN THE APPLICATOR WAS QUALIFIED AT THE FACTORY. ADJUSTMENT MAY BE NECESSARY WHEN RUNNING APPLICATOR IN THE FIELD.
- UNLESS SPECIFIED OTHERWISE TORQUE VALUES SHALL BE USED PER DOCUMENT, 101-35000.

***WARNING**
 ON INSTALLATION, SET WIRE DISC TO CRIMP HEIGHT REFERENCE SETTING FOR LARGEST WIRE SIZE. CRIMP HEIGHT REFERENCE SETTINGS GREATER THAN THE VALUE SHOWN MAY CAUSE DAMAGE TO THE CRIMP TOOLING, REFER TO THE INSTRUCTION SHEET FOR PROPER SETUP AND ADJUSTMENTS.

LOC	DIST	REVISIONS					
		P	LTN	DESCRIPTION	DATE	OWN	APVD
A	66	-	-	SEE SHEET 1	-	-	-

-	1	1	2119082-4	CAM, SNAIL, INSULATION ADJUSTMENT	244	
-	1	1	2079764-1	WASHER, WAVE SPRING, CREST-TO-CREST	243	
3	-	1	2119083-1	RETAINER, INSULATION DIAL	242	
-	-	1	2119580-1	MECHANICAL FEED ASSEMBLY	239	
-	1	-	2844940-3	AIR FEED MODULE	238	
-	1	1	1-18028-0	WASHER, FLAT, REG M8	192	
-	4	4	2079383-9	SCR, BHSC, RoHS (M6 X 20)	186	
3	-	1	1-1752354-0	STANDOFF, HOLD-DOWN	180	
-	1	1	6-993111-6	PIN, SLOTTED SPRING 3.0 X 14.0	177	
-	1	1	8-22280-7	SPRING, COMPRESSION	176	
-	1	1	1752353-2	GUIDE PIN, HOLDDOWN	175	
-	1	1	1901680-2	GUIDE PIN, HOLDDOWN	174	
-	REF	REF	994970-2	COUNTER, MAGNETIC	164	
-	1	-	2119641-2	FEED CAM, AIR FEED	152	
-	1	1	2168083-8	SCR, SKT HD CAP, RoHS, M4 X 16	144	
-	-	1	2119653-2	FEED CAM, POST FEED	142	
-	1	1	2119655-6	APPLICATOR BASIC ASSEMBLY, EF	141	
-	1	1	1803518-1	RAM ASSEMBLY, EF PACIFIC	140	
-	1	1	455888-4	SPACER, CRIMPER	82	
-	1	1	1803607-4	DOCUMENTATION PACKAGE	71	
-	2	2	2-18032-2	SCR, SET, FLT PNT, M3 X 10.0	70	
-	1	1	2119740-1	TAG, IDENTIFICATION	67	
-	2	2	2168078-1	SCREW, DRIVE, RH, RoHS, 2 x .188	66	
-	1	1	1901681-1	HOLDDOWN, TERMINAL	65	
-	2	2	2168400-5	SHCS, LOW HEAD, RoHS, M4 X 20	64	
-	1	1	5-18022-5	SCR, HEX HD CAP, M4 X 6.0	59	
-	-	1	2063961-3	FEED FINGER	58	
-	3	3	2168400-4	SHCS, LOW HEAD, RoHS, M4 X 8	57	
-	2	2	2168083-3	SCR, SKT HD CAP, RoHS, M4 X 12.0	56	
-	2	2	5018030-1	NUT, HEX, REG, RoHS, M3	54	
-	2	2	986965-8	NUT, LOCK, HEX, TORQUE (M4)	53	
-	1	1	1-5018030-0	NUT, HEX, REG, RoHS, M3.5	52	
-	1	-	2063961-3	FEED FINGER	51	
-	1	2	18023-9	SCR, SKT HD CAP M4 X 6.0	49	
-	-	1	2119652-1	FEED CAM, PRE FEED	48	
-	1	1	1803602-1	SCR, BHSC, RoHS (M8 X 25)	41	
-	7	7	1-18028-2	WASHER, FLAT, REG M4	33	
-	2	2	2168083-9	SCR, SKT HD CAP, RoHS, M4 X 20	31	
-	2	2	1-2168083-0	SCR, SKT HD CAP, RoHS, M4 X 10	29	
-	1	1	240639-1	STRIPPER (MACHINING)	27	
-	2	2	1-2168083-5	SCR, SKT HD CAP, RoHS, M4 X 30	25	
-	1	1	1752371-5	PLATE, STRIP GUIDE	24	
-	1	1	240825-7	PLATE, STRIP HOLD DOWN	23	
-	2	2	2-22281-3	SPRING, COMPRESSION	22	
-	1	1	1803292-4	DRAG	20	
-	2	2	1901259-5	GUIDE, LOWER STRIP	18	
-	1	1	3-240641-0	SPACER	16	
-	1	1	1752360-1	SPACER, HOLD-DOWN	13	
1	-	1	240644-1	PLATE, REAR SHEAR	11	
-	-	-	-	-	10	
1	-	1	690482-4	PLATE, FRONT SHEAR	9	
1	1	1	7-1803001-0	ANVIL, COMBINATION, END FEED	8	
1	-	1	1-2217206-0	BLADE, SLUG	7	
-	-	-	-	-	6	
-	1	1	240641-5	SPACER	5	
-	1	1	3-238011-1	BLOCK, CRIMPER SPACER	4	
1	1	1	8-1633965-3	CRIMPER, INSULATION O PREMIUM	3	
-	1	1	455888-8	SPACER, CRIMPER	2	
1	1	1	9-1633609-3	CRIMPER, WIRE	1	
-	77	22	21	PART NO	DESCRIPTION	ITEM NO

PACIFIC VERSION
 Shown on sheets 3 of 4 & 4 of 4
 (Atlantic version shown on sheets 1 of 4 & 2 of 4)

DIMENSIONS:		TOLERANCES UNLESS OTHERWISE SPECIFIED:		DRAWN		DATE	
mm	0 PLC ±	1 PLC ±	2 PLC ±	J. HOU	01JAN2015	STE TE Connectivity Harrisburg, PA 17105-3608	
	3 PLC ±	4 PLC ±	ANGLES ±	L. ZHANG	01JAN2015	NAME	
	FINISH			J. GUO	01JAN2015	PRODUCT SPEC	
MATERIAL						APPLICATION SPEC	
						SIZE CAGE CODE DRAWING NO RESTRICTED TO	
						A 00779 C=2150511	
						Customer Accessible Production Drawing SCALE 1:1 SHEET 3 OF 4 REV C	

LOC		DIST		REVISIONS			
A	66	P	LTM	DESCRIPTION	DATE	OWN	APVD
		-		SEE SHEET 1	-	-	-

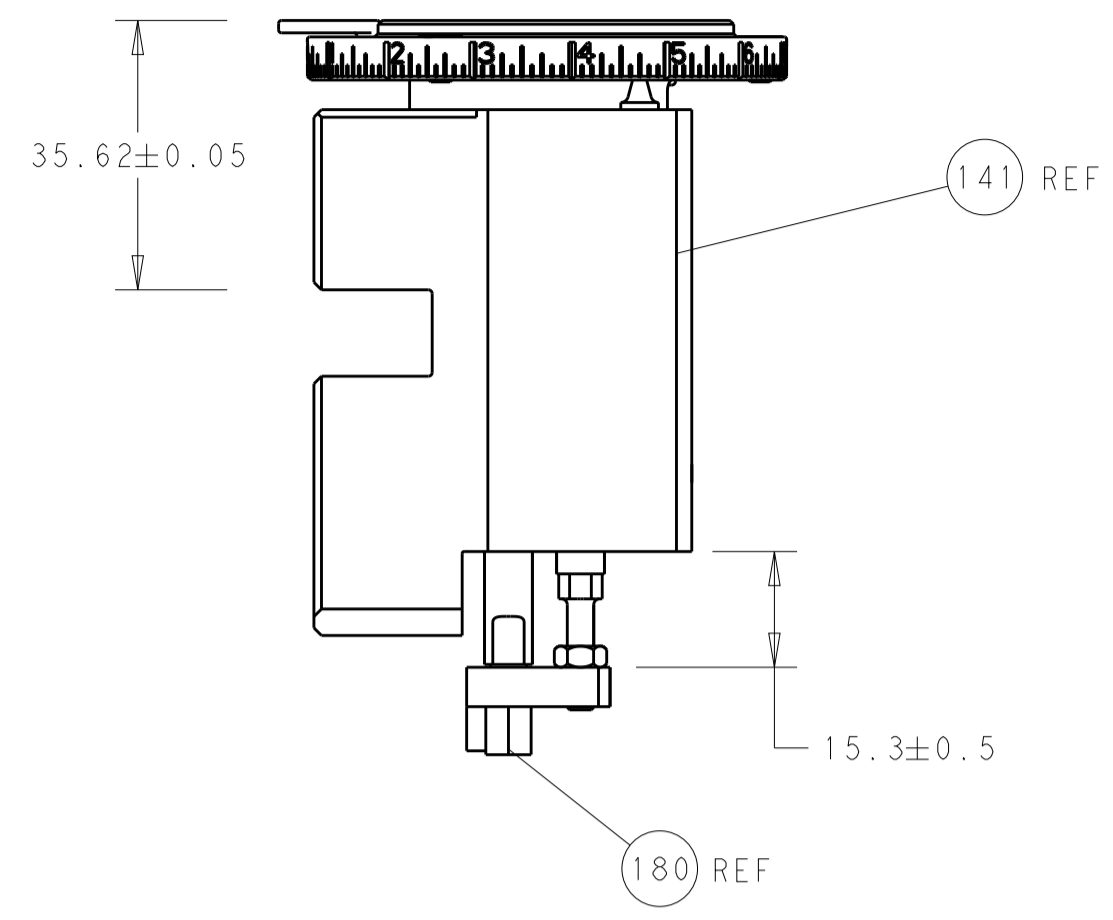

RAM AND HOLDDOWN SET-UP

FEED TYPE
MECHANICAL

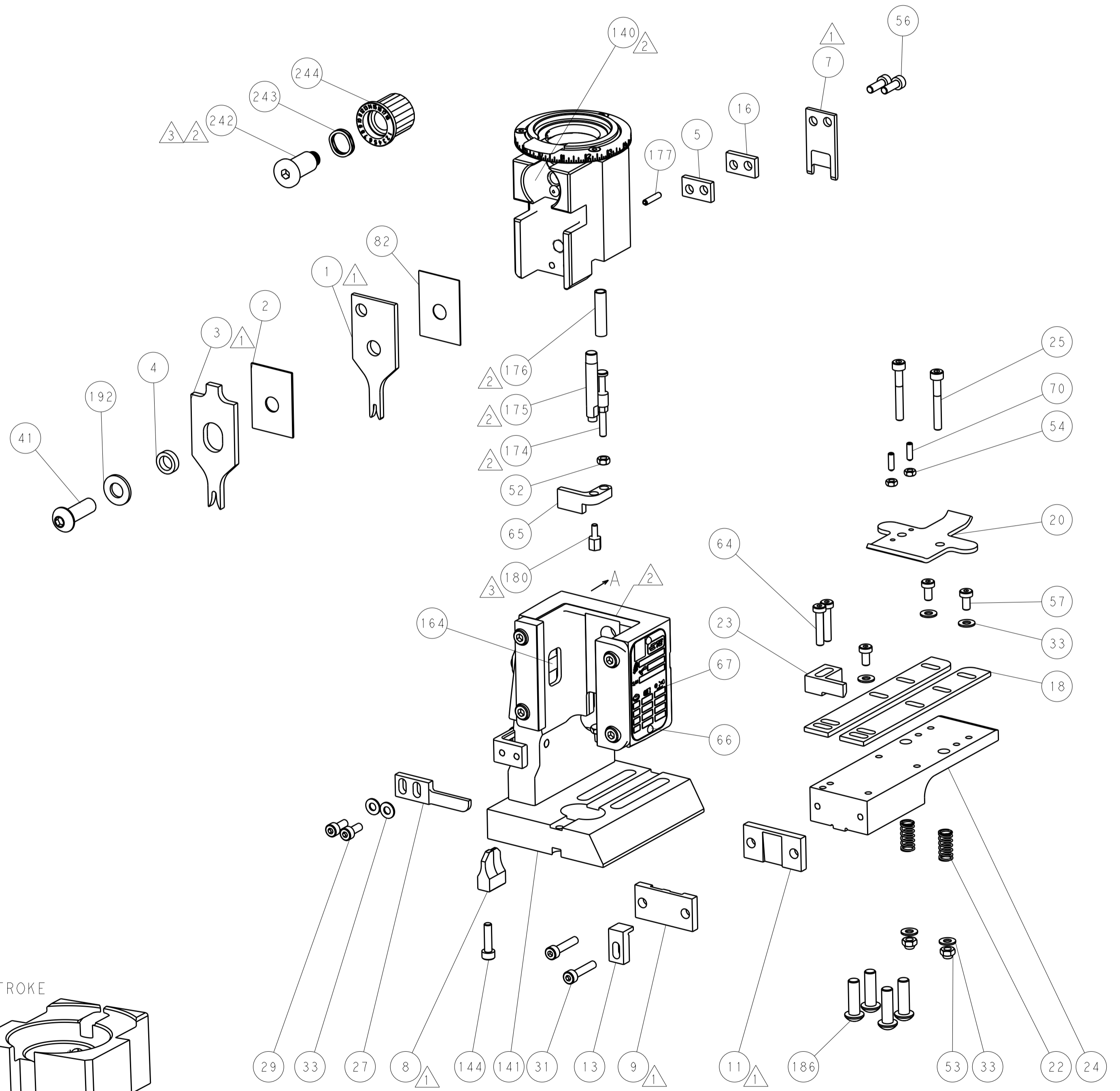
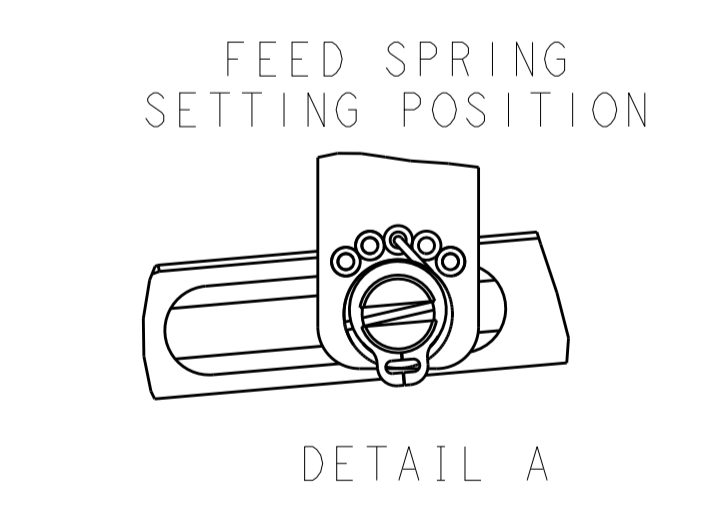
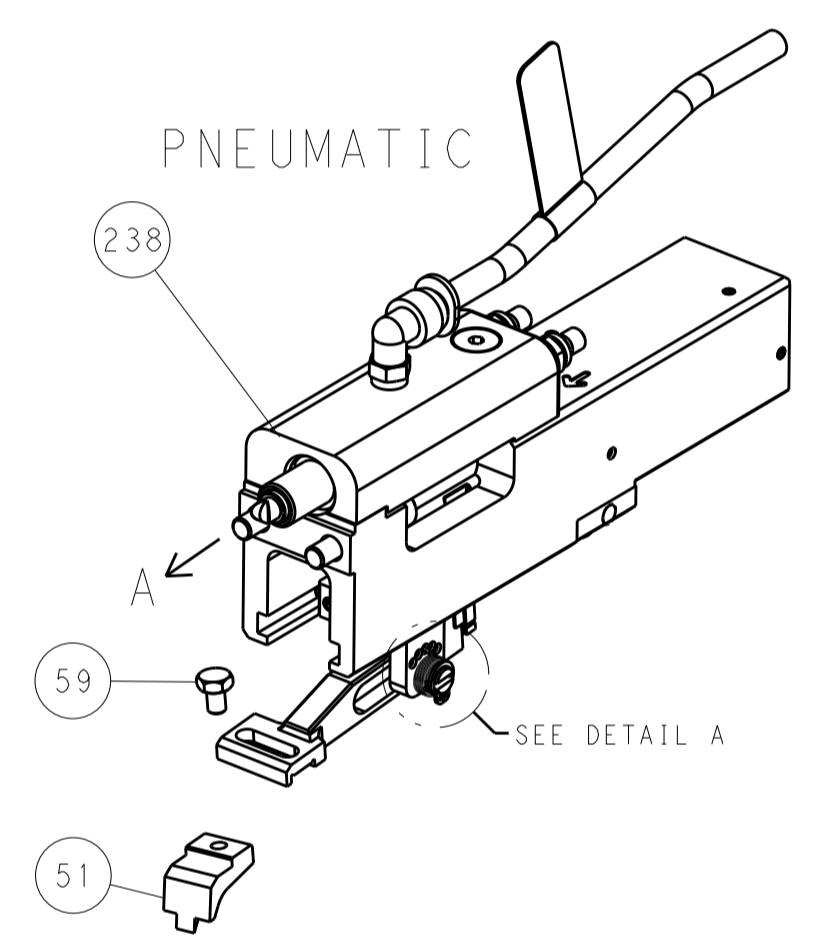
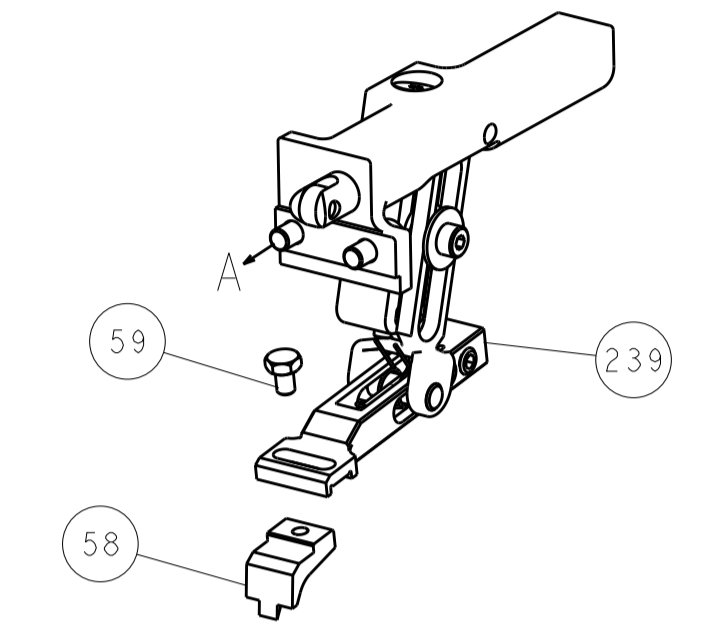

CAM POSITIONS

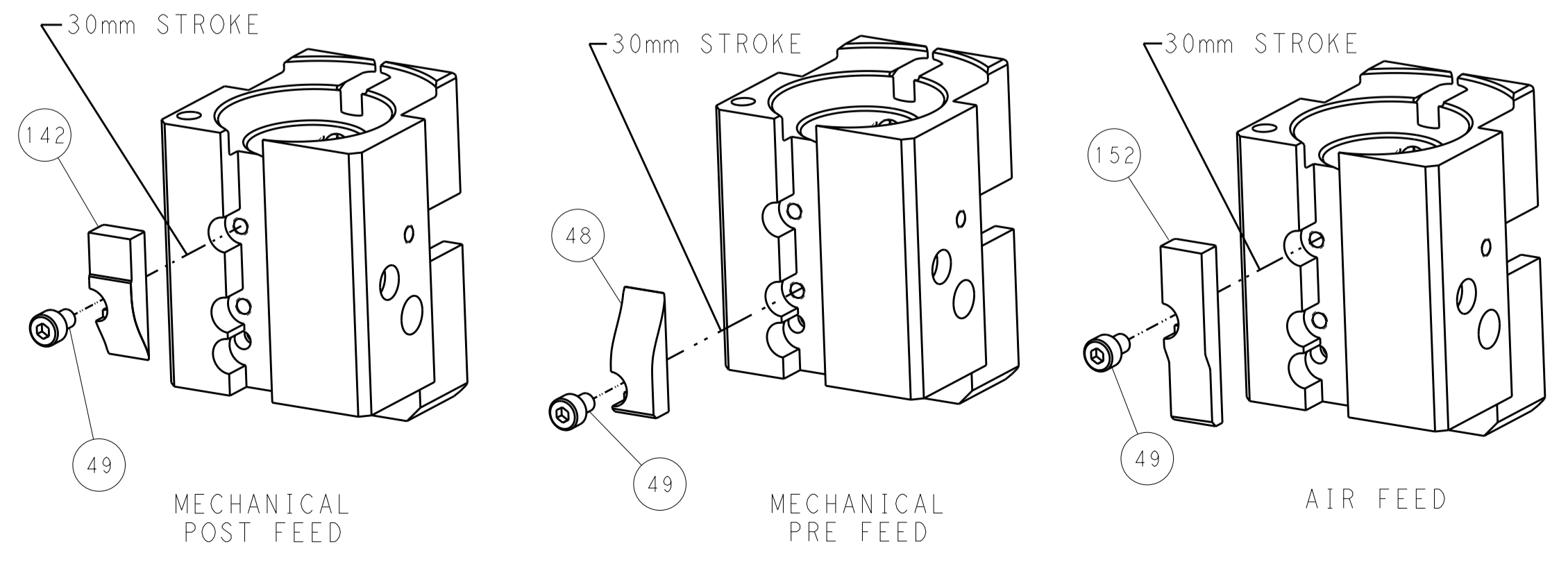

PACIFIC VERSION
 Shown on sheets 3 of 4 & 4 of 4
 (Atlantic version shown on sheets 1 of 4 & 2 of 4)

DIMENSIONS:		TOLERANCES UNLESS OTHERWISE SPECIFIED:		DWN J. HOU 01JAN2015		STE TE Connectivity	
mm	0 PLC ±	1 PLC ±	2 PLC ±	3 PLC ±	4 PLC ±	5 PLC ±	Harrisburg, PA 17105-3608
MATERIAL:	FINISH:	WEIGHT:	APVD: L. ZHANG 01JAN2015	NAME:	Ocean End Feed Applicator		RESTRICTED TO:
Customer Accessible Production Drawing				SCALE: 1:1	SHEET 4 OF 4	REV C	