

GEOMETRY & PLATING ABOVE THE LINE IS NOT CONTROLLED BY THIS DOCUMENT

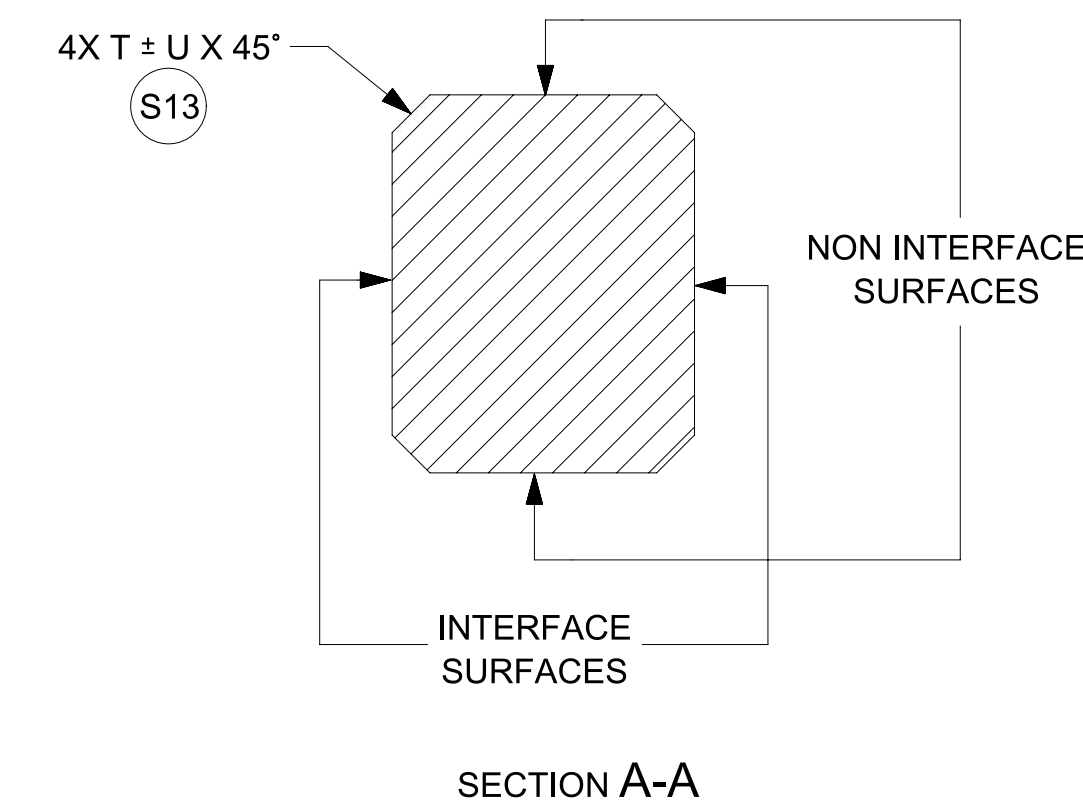
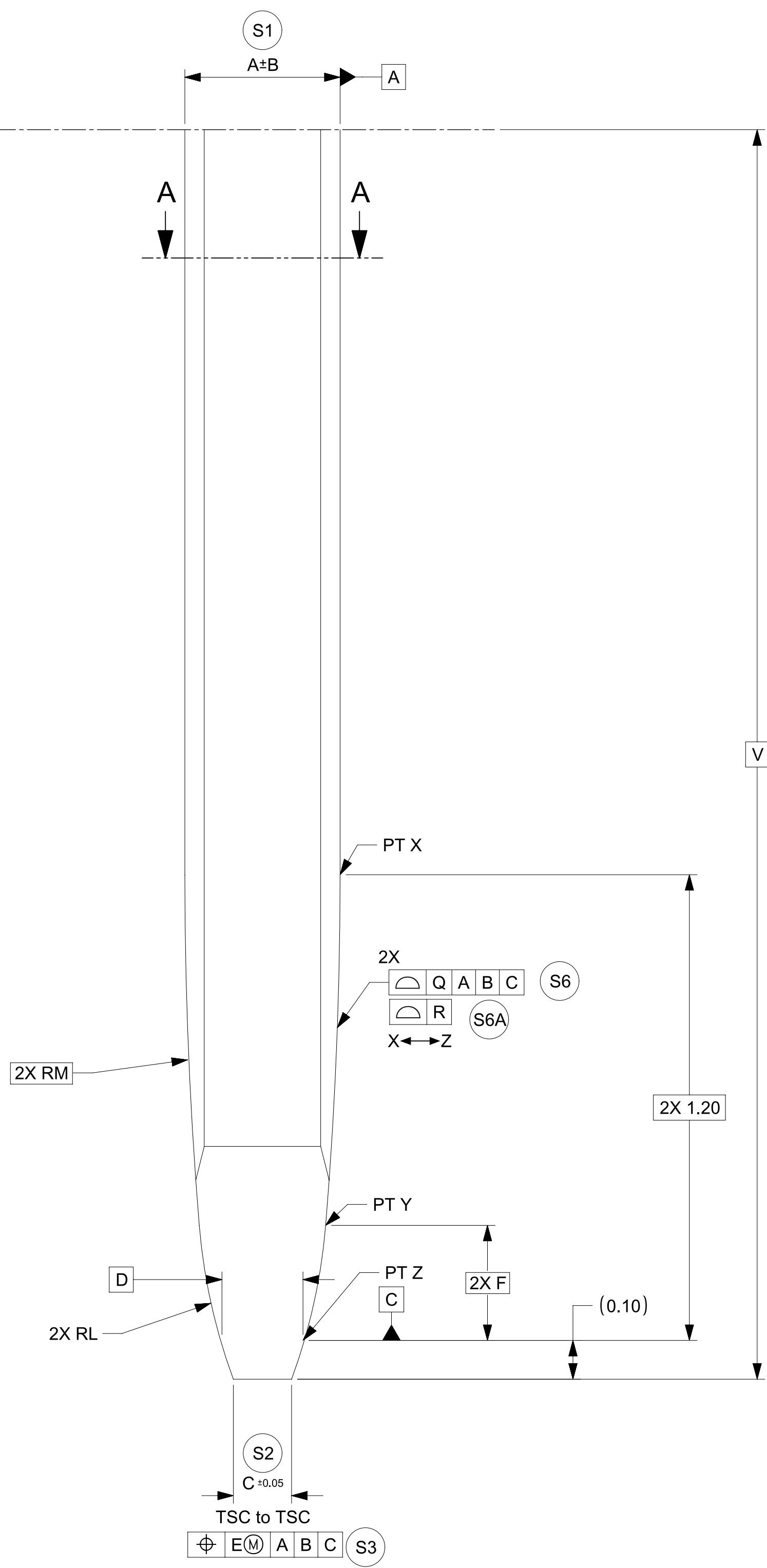

SECTION A-A

TABLE 1			DRAWING DIMENSIONS																		
Model NO.	Description	Application	A	B	C	D	E	F	G	H	J	L	M	N	P	Q	R	T	U	V	W
34735-0004_FM_000	0.50mm BLADE	HEADER	0.40	0.015	0.15	0.216	0.05	0.296	0.50	0.03	0.05	1.5	11	0.20	0.50	0.10	0.06	0.05	0.03	4.0 MIN	0.08
34735-0001_FM_000	0.64mm BLADE - NORMAL THICKNESS	HEADER	0.64	0.03	0.25	0.356	0.10	0.285	0.64	0.03	0.05	1	7	0.25	0.55	0.10	0.06	0.05	0.03	5.5 MIN	0.08
34735-0002_FM_000	0.64mm BLADE - REDUCED THICKNESS	HEADER	0.625	0.015	0.234	0.341	0.10	0.285	0.64	0.03	0.05	1	7	0.25	0.55	0.10	0.06	0.05	0.03	5.5 MIN	0.08
34735-0006_FM_000	1.20mm BLADE	HEADER	0.60	0.015	0.21	0.316	0.10	0.285	1.00	0.05	0.05	1	7	0.59	0.55	0.10	0.06	0.05	0.03	5.5 MIN	0.13
34735-0003_FM_000	1.50mm BLADE	HEADER	0.80	0.03	0.25	0.321	0.10	1.10	1.50	0.05	0.10	4.775	1.083	0.5	1.68	0.10	0.06	0.05	0.03	5.0 MIN	0.13
34735-0010_FM_000	2.8mm BLADE	HEADER	0.80	0.025	0.20	0.345	0.10	0.314	2.50	0.10	0.10	1	4	1.80	1.10	0.15	0.06	0.06	0.05	9.5 MIN	0.25
34735-0011_FM_000	6.3mm BLADE	HEADER	0.80	0.025	0.31	0.345	0.10	0.314	6.0	0.25	0.20	1	4	3.90	1.10	0.15	0.06	0.06	0.05	10.5 MIN	0.13
34735-0012_FM_000	1.20mm BLADE	INLINE	0.60	0.015	0.21	0.316	0.10	0.285	1.20	0.05	0.05	1	7	0.59	0.55	0.10	0.06	N/A	N/A	5.5 MIN	0.13

FUNCTIONAL SYMBOLS $\nabla_A = 0$ $\nabla_C = 0$ $\nabla_P = 0$	THIS DRAWING CONTAINS INFORMATION THAT IS PROPRIETARY TO MOLEX ELECTRONIC TECHNOLOGIES, LLC AND SHOULD NOT BE USED WITHOUT WRITTEN PERMISSION		CURRENT REV DESC:		
	DIMENSION UNITS mm	SCALE 100:1	PHASE: Design Production EC NO: CO-000000508 DRWN: Raghavendra MV APPR: Deepak Patil 2022-01-31 2022-02-07 2022-02-09		
DIVISIONAL SYMBOLS	GENERAL TOLERANCES (UNLESS SPECIFIED)		INITIAL REVISION:		PRODUCT SALES DRAWING
	4 PLACES ± 0.00000 3 PLACES ± 0.0150 2 PLACES ± 0.050 1 PLACE ± 0.10 0 PLACES ± 0.00	DRWN: Raghavendra MV APPR: Deepak Patil 2022-01-31 2022-02-09		DOCUMENT NUMBER 347350050	
DRAFT WHERE APPLICABLE MUST REMAIN WITHIN DIMENSIONS		THIRD ANGLE PROJECTION	DRAWING A1-SIZE	SERIES 34735	MATERIAL NUMBER CUSTOMER SHEET NUMBER 2 OF 2

NOTES

1. GENERAL:

- 1.1. ALL PRODUCT SPECIFICATIONS AND THEIR RELATED DOCUMENTS USING THIS FEATURE MUST REFERENCE THIS DOCUMENT AS THE CONTROLLING SPECIFICATION AND USE THE SAME BALLOON NUMBERS.
- 1.2. COMPLIANCY TO THIS DOCUMENT:
 - a) COMPLIANCY MAY BE CLAIMED BY MEETING THE REQUIREMENTS IN THIS SPECIFICATION WITH THE DEVIATION IDENTIFIED AND MAY BE REFERENCED IN OTHER DOCUMENTS (DRAWINGS, DVP&R, ETC.) AS 'CONFORMS TO MOLEX 347350050 REV X.X'.
 - b) PRODUCTS DESIGNED AFTER THE DATE OF RELEASE OF THIS DOCUMENT SHALL BE COMPLIANT TO THE CURRENT REVISION OF THIS DOCUMENT.
 - c) PRODUCTS THAT HAVE MET PREVIOUS REVISION(S) OF THIS DOCUMENT SPECIFICATION SHALL STILL BE CONSIDERED 'MOLEX STANDARDS COMPLIANT' TO THOSE REVISIONS AND DO NOT NEED TO BE RE-VALIDATED.
- 1.3. DEVIATIONS TO THIS DOCUMENT ARE ALLOWABLE UNDER THE FOLLOWING CONDITIONS:
 - a) ALL DEVIATIONS SHALL SHOW EQUAL OR BETTER PERFORMANCE (ELECTRICAL/MECHANICAL) AS REQUIRED BY VALIDATION SPECIFICATION.
 - b) EXCEPTIONS ARE CLEARLY IDENTIFIED ON THE PRODUCT SPECIFICATION.
 - c) ALL DEVIATIONS ARE APPROVED BY THE FOLLOWING INDIVIDUALS:
 - PERSON WHO HAS INTERFACE RESPONSIBILITY
 - PERSON WITH DESIGN STANDARD APPROVER AUTHORITY
 - d) ALL RECORDS OF DEVIATION APPROVALS SHALL BE INCLUDED WITH CHANGE NOTICE DOCUMENTATION.

2. DESIGN - MATERIALS:

- 2.1. BASE MATERIAL TYPE : COPPER ALLOY

3. DESIGN - GEOMETRY:

- 3.1. THE 3-D CAD DATA IS BASIC (WITHOUT TOLERANCE) AND MASTER FOR THIS PART WITH EXCEPTION TO UNDERLINED DIMENSIONS. DIMENSIONAL INFORMATION NOT SHOWN ON THIS DRAWING IS DEFINED BY THE DATA FILE AT ITS LATEST REVISION.
- 3.2. PRODUCT DESIGN MODEL NUMBER(S): SEE BOM TABLE
- 3.3. GEOMETRIC DIMENSIONS AND TOLERANCES PER ASME Y14.5-2009
- 3.4. EDGES OF UNDEFINED SHAPE PER ISO 13715.
- 3.5. DIMENSIONS AND TOLERANCES APPLY BEFORE AND AFTER PLATING.
- 3.6. GENERAL TOLERANCES: SEE TITLE BLOCK

4. DESIGN - MANUFACTURING:

- 4.1. ANY REMAINING PROCESS LUBRICANT MUST NOT VARNISH OR DEGRADE ELECTRICAL PERFORMANCE. PROCESS LUBRICANTS SHOULD BE APPROVED BY THE RESPONSIBLE ENGINEER.
- 4.2. ALLOWABLE BURR: 0.03mm MAX UNLESS OTHERWISE SPECIFIED
- 4.3. FOR UNPLATES BLADES - TOOLING MARKS SPANNING ACROSS OR ALONG THE INTERFACING PROFILE OF THE BLADE SHOULD BE FURTHER INSPECTED. A TOOLING MARK DEEPER THAN 1 MICRON SHOULD NOT BE ACCEPTED.

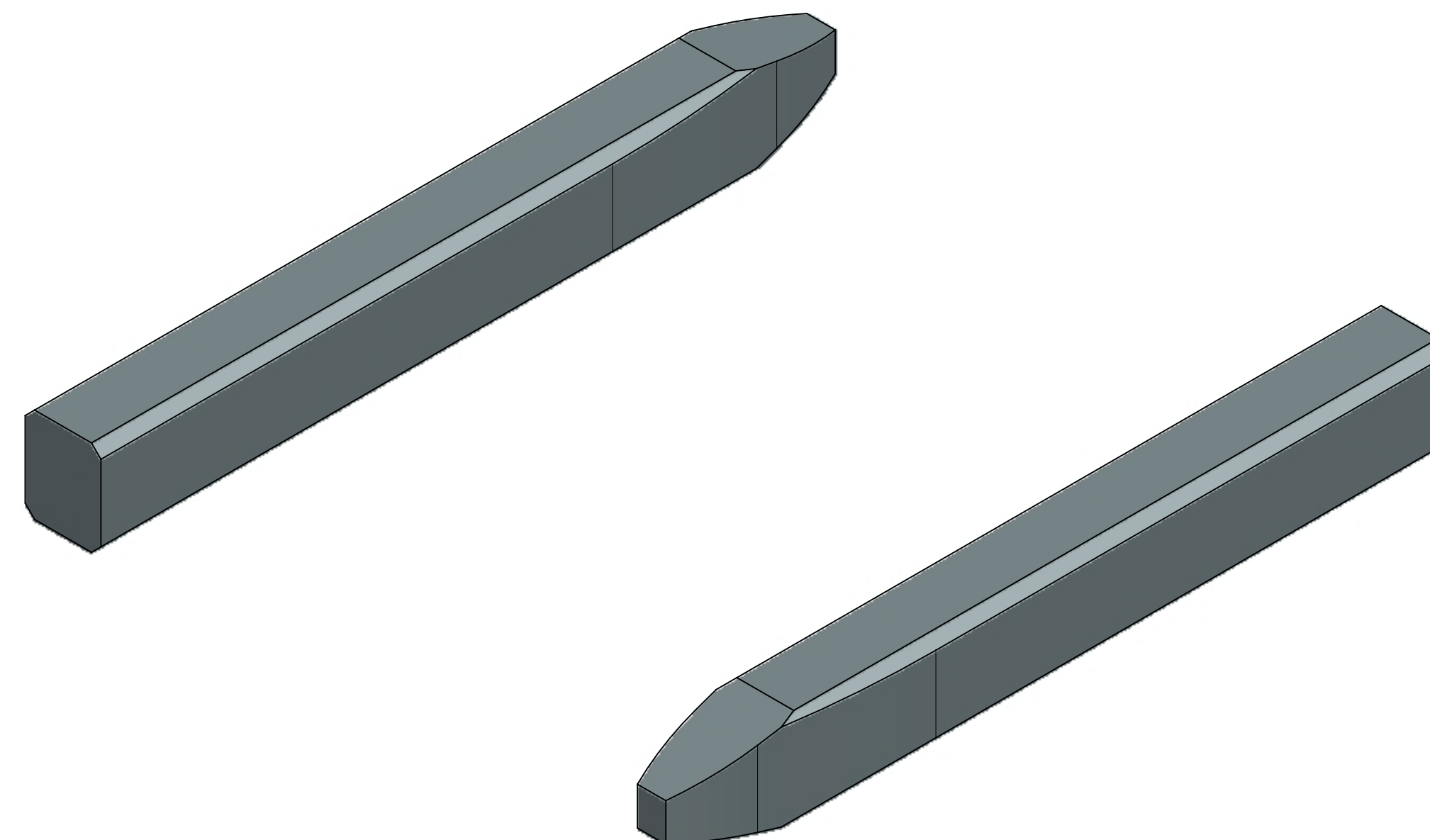

SCALE 50:1

0.5 MM PIN VIEW SHOWN FOR REPRESENTATION PURPOSES ONLY

THIS DRAWING CONTAINS INFORMATION THAT IS PROPRIETARY TO MOLEX ELECTRONIC TECHNOLOGIES, LLC AND SHOULD NOT BE USED WITHOUT WRITTEN PERMISSION										
FUNCTIONAL SYMBOLS	DIMENSION UNITS	SCALE	CURRENT REV DESC:							
$\frac{F}{A} = 0$	mm	50:1	PHASE: Design Production EC NO: CO-00000508 DRWN: Raghavendra MV 2022-01-31 CHK'D: Nathan Song 2022-02-07 APPR: Deepak Patil 2022-02-09 INITIAL REVISION: DRWN: Raghavendra MV 2022-01-31 APPR: Deepak Patil 2022-02-09							
$\frac{F}{C} = 0$	GENERAL TOLERANCES (UNLESS SPECIFIED)									
$\frac{F}{P} = 0$	ANGULAR TOL ± 0.5°									
DIVISIONAL SYMBOLS	4 PLACES ± 0.00000									
	3 PLACES ± 0.0150		PRODUCT SALES DRAWING							
	2 PLACES ± 0.050		DOCUMENT NUMBER				DOC TYPE	DOC PART	REVISION	
	1 PLACE ± 0.10		347350050				PSD	000	A21	
	0 PLACES ± 0.00		MATERIAL NUMBER				CUSTOMER		SHEET NUMBER	
DRAFT WHERE APPLICABLE MUST REMAIN WITHIN DIMENSIONS			THIRD ANGLE PROJECTION	DRAWING	SERIES			1 OF 2		
				A1-SIZE	34735					

molex

DESIGN STANDARD
HEADER PIN & BLADE TIP GEOMETRY FOR MATING
TO HARNESS TERMINALS

PRODUCT SALES DRAWING

TABLE OF CONTENTS	
SHEET NO.	SHEET DESCRIPTION
1	NOTES AND PART NUMBER CHART
2	KEY CONFIGURATION
3	RECEPTACLE CONNECTOR ASSEMBLY

PART NUMBER AND MATING INTERFACE CHART						
PART NUMBER	KEY	COVER COLOR	TERMINAL POSITIONS PLUGGED	CPA INCLUDED	INTERFACE PART NUMBER	
349671001	A	BLACK	NONE	YES	349681801	
349671002	B	LIGHT GRAY	NONE	YES	349681802	
349671003	C	DARK GRAY	NONE	YES	349681803	
349671004	D	STONE GRAY	NONE	YES	349681804	
349671005	A	BLACK	NONE	NO	349681801	
349671006	B	LIGHT GRAY	NONE	NO	349681802	
349671007	C	DARK GRAY	NONE	NO	349681803	
349671008	D	STONE GRAY	NONE	NO	349681804	
349671151	A	BLACK	5, 6, 7, 8	YES	349681801	

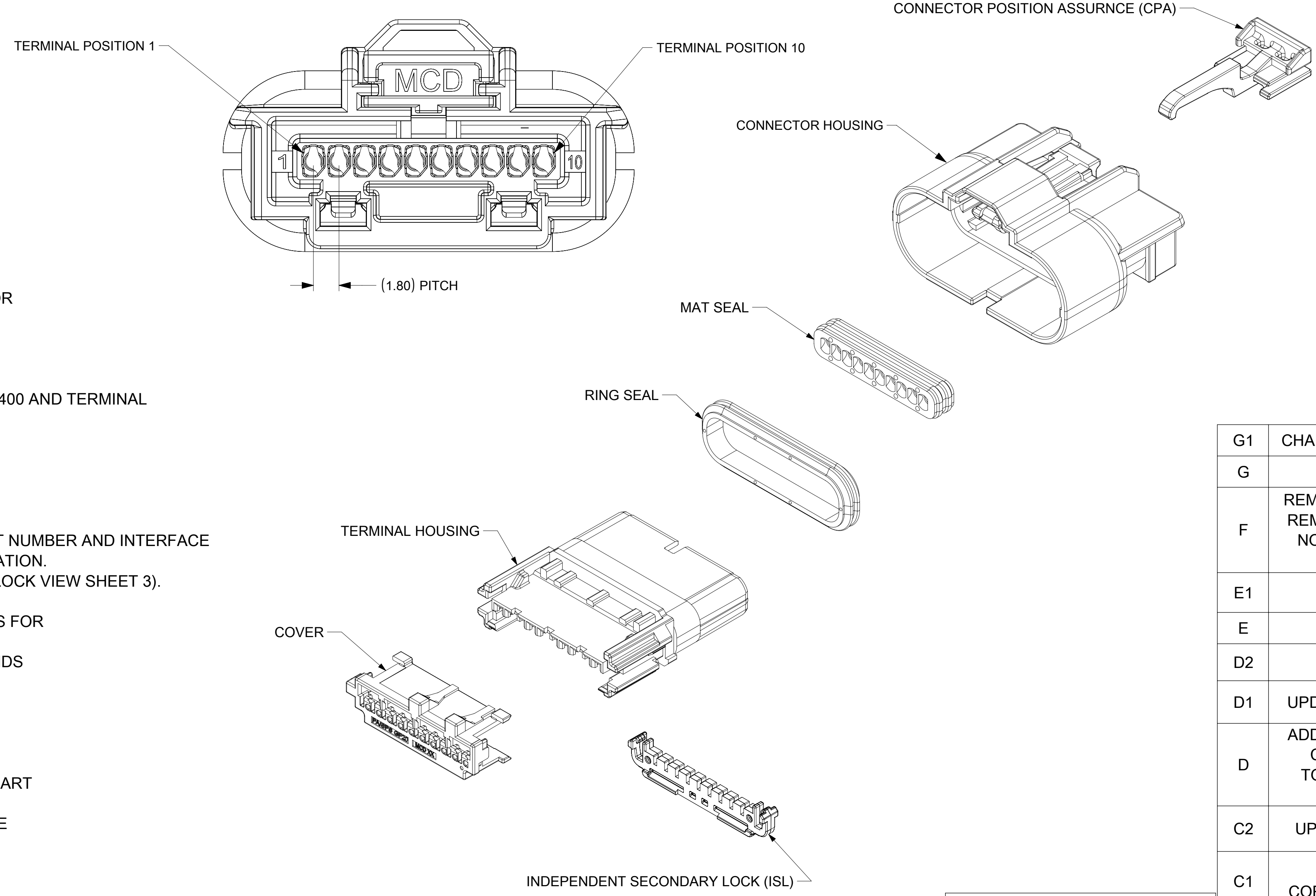
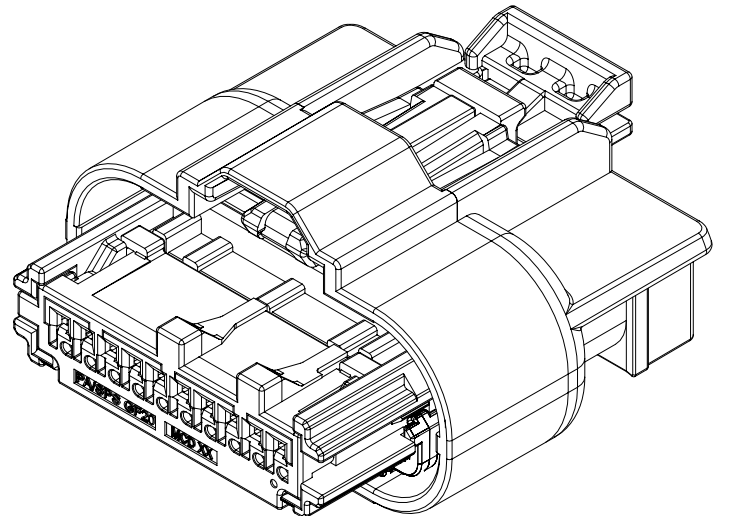

NOTES: VALID UNLESS OTHERWISE SPECIFIED

1. GENERAL:
 - A. APPLICATION SPECIFICATION SEE: AS-34894-0001
-CONTAINS: PRODUCT INTRODUCTION, PRODUCT SUMMARY, CONNECTOR ASSEMBLY, PACKAGING INFORMATION, CONNECTOR MATING, SERVICE INSTRUCTIONS, ELECTRICAL CONTINUITY CHECKING, CRIMPING, AND TROUBLESHOOTING.
 - B. TERMINALS TO BE USED WITH THIS ASSEMBLY:
MOLEX CTX50 SEALED RECEPTACLE TERMINALS
FOR INFORMATION ON TERMINALS SEE MOLEX DRAWING 349050400 AND TERMINAL PRODUCT SPECIFICATION PS-34905-001.
 - C. CONNECTOR PRODUCT SPECIFICATION SEE 349670001 PS
CONTAINS: PRODUCT INTRODUCTION, PRODUCT SUMMARY, RATINGS AND PRODUCT VALIDATION.
VALIDATED TO USCAR 2 REV 6.
RATINGS: T3 V1 S2
 - D. DESIGNED TO MATE WITH DEVICE INTERFACE AS SPECIFIED IN PART NUMBER AND INTERFACE CHART. SEE MOLEX DRAWING 349681800 FOR INTERFACE SPECIFICATION.
 - E. ASSEMBLY SHIPPED WITH ISL IN PRE-LOCK POSITION (SEE ISL PRE-LOCK VIEW SHEET 3).
 - F. PACKAGING SPECIFICATION PER MOLEX DRAWING: PK-31301-898
 - G. PARTS MUST BE IN COMPLIANCE TO MOLEX CHEMICAL SUBSTANCES FOR PRODUCTS AND PACKAGING SPECIFICATION: ES-40000-5016
 - H. DATA MUST BE SUBMITTED UNDER THE MOLEX PART NUMBER TO IMDS (COMPANY ID#13255)
2. DESIGN - MATERIALS:
 - CONNECTOR HOUSING: SPS/NYLON GF20 BLACK
 - TERMINAL HOUSING: SPS/NYLON GF20 BLACK
 - COVER: SPS/NYLON GF20 COLORS IN PART NUMBER CHART
 - ISL: SPS GF30 NATURAL
 - MAT SEAL: INHERENTLY LUBRICATED SILICONE LIGHT BLUE
 - RING SEAL: INHERENTLY LUBRICATED SILICONE RUST RED
 - CPA (OPTIONAL): PBT GF30 RED
3. DESIGN - GEOMETRY:
 - A. ALL GRAPHIC DATA IS BASIC (NO TOLERANCE) AND MUST BE TAKEN FROM THE DATA FILE AT ITS LATEST REVISION.
 - B. GEOMETRIC DIMENSIONS AND TOLERANCES PER ASME Y14.5M-2009
 - C. EDGES AND UNDIMENSIONED DETAILS PER ISO13715
 - D. CORNERS SHOWN AS SHARP TO BE R 0.2 MAX.
 - E. LETTERING SHALL BE 0.15 MAX RAISED IN 0.25 MAX RECESS PAD.
THIS INCLUDES RECYCLING CODE, CAVITY ID, VENDOR IDENTIFICATION, AND CUSTOMER MATERIAL NUMBER.
 - F. VISUAL DEFECTS SHALL MEET COSMETIC STANDARD PS-45499-002 (Class B).
 - G. PARTS ARE LASER MARKED WITH PART NUMBER AND DATE CODE

G1	CHANGED BASIC DIMS TO REF DIMS
G	ADDED PART NUMBER
F	REMOVED DEVELOPMENT NOTICE. REMOVED TERMINAL TABLE FROM NOTES. ADDED REF DIMS TO ID DATUMS.
E1	REMOVED PART NUMBER
E	MODIFIED KEYS
D2	ADDED PART NUMBER
D1	UPDATED INFORMATION IN NOTES
D	ADDED PART NUMBER TO CHART. COVER GEOMETRY UPDATE. TOLERANCE CHANGES. NOTES CHANGES.
C2	UPDATED PART NUMBER CHART
C1	ADDED PART NUMBER. CORRECTIONS & CLARIFICATIONS
C	RELEASE
REV	REV DESCRIPTION

INSPECTION NUMBER LOG	
LAST NUMBER:	15
ADDED:	2,4,7,8,9,13,14

FUNCTIONAL SYMBOLS $\nabla A = 0$ $\nabla E = 0$ $\nabla P = 0$ DIVISIONAL SYMBOLS	THIS DRAWING CONTAINS INFORMATION THAT IS PROPRIETARY TO MOLEX ELECTRONIC TECHNOLOGIES, LLC AND SHOULD NOT BE USED WITHOUT WRITTEN PERMISSION	DIMENSION UNITS: mm SCALE: 1:1	CURRENT REV DESC: CHANGED BASIC DIMS TO REF DIMS	 MINI50 SEALED 1X10 RCPT ASSY PRODUCT CUSTOMER DRAWING	
	GENERAL TOLERANCES (UNLESS SPECIFIED) ANGULAR TOL $\pm 0.3^\circ$	EC NO: 657824 DRWN: MLI149 CHK'D: JCONDON APPR: JCONDON	2021/03/09 2021/03/11 2021/03/11		DOCUMENT NUMBER: 349671000 DOC TYPE: PSD DOC PART: 000 REVISION: G1
	4 PLACES \pm 3 PLACES \pm 2 PLACES ± 0.1 1 PLACE ± 0.2 0 PLACES \pm	INITIAL REVISION: DRWN: MNS02 APPR: KDEKOSKI	2016/04/26 2016/05/19		MATERIAL NUMBER: 34967 CUSTOMER:
	DRAFT WHERE APPLICABLE MUST REMAIN WITHIN DIMENSIONS	THIRD ANGLE PROJECTION 	DRAWING: A1-SIZE SERIES: 34967		SHEET NUMBER: 1 OF 3

SHEET DESCRIPTION
KEY CONFIGURATIONS

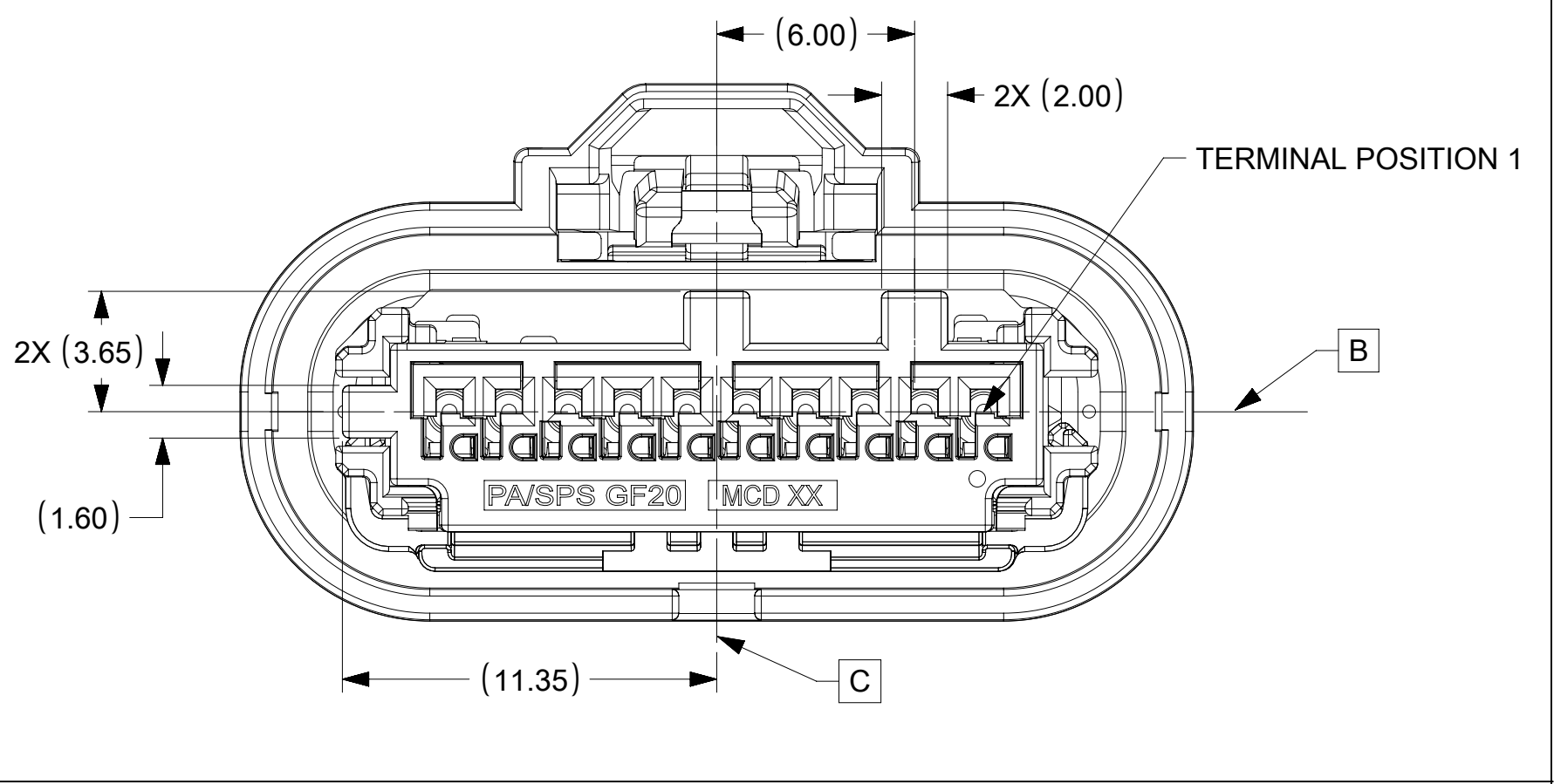

KEY A

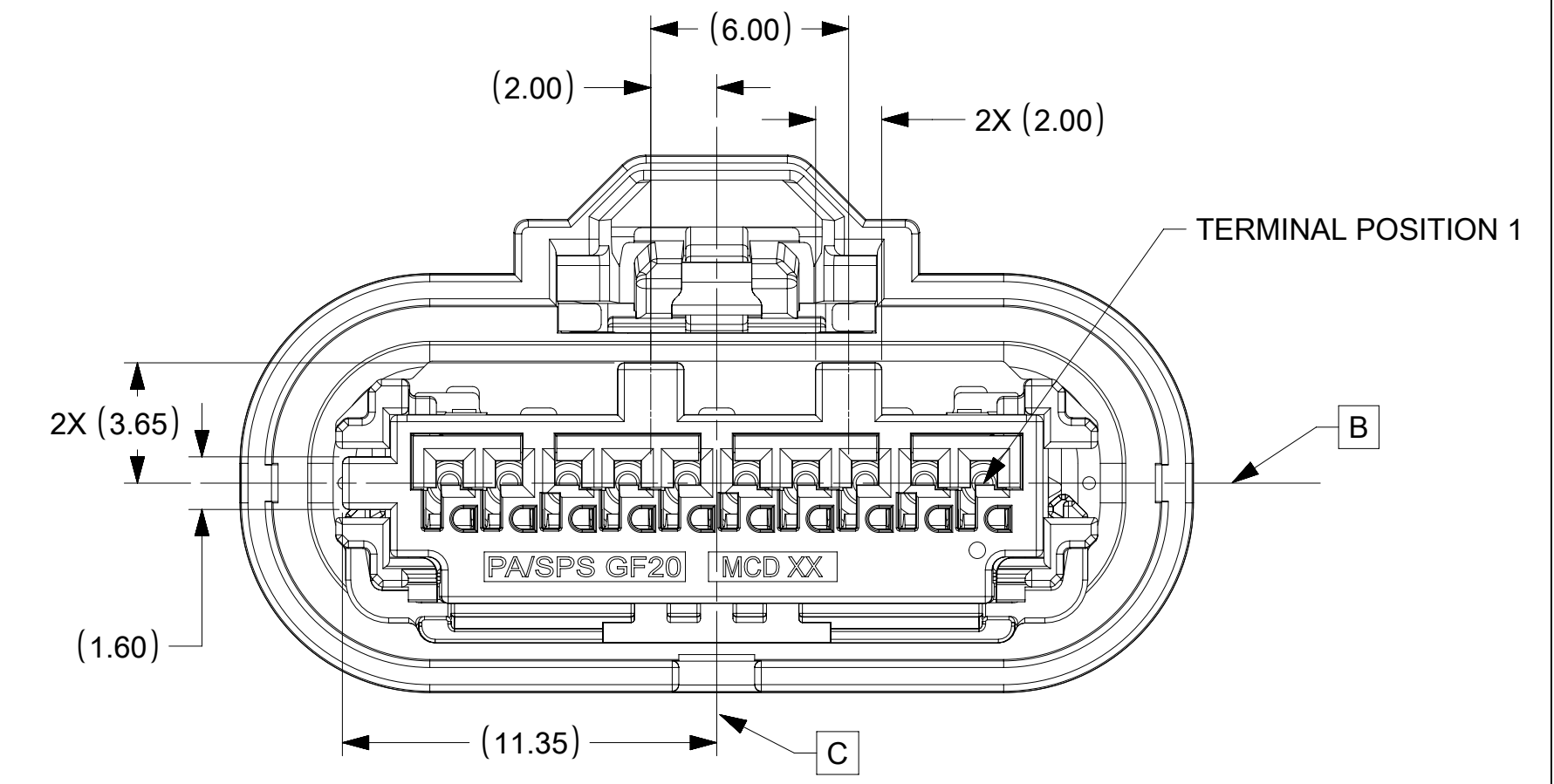

KEY B

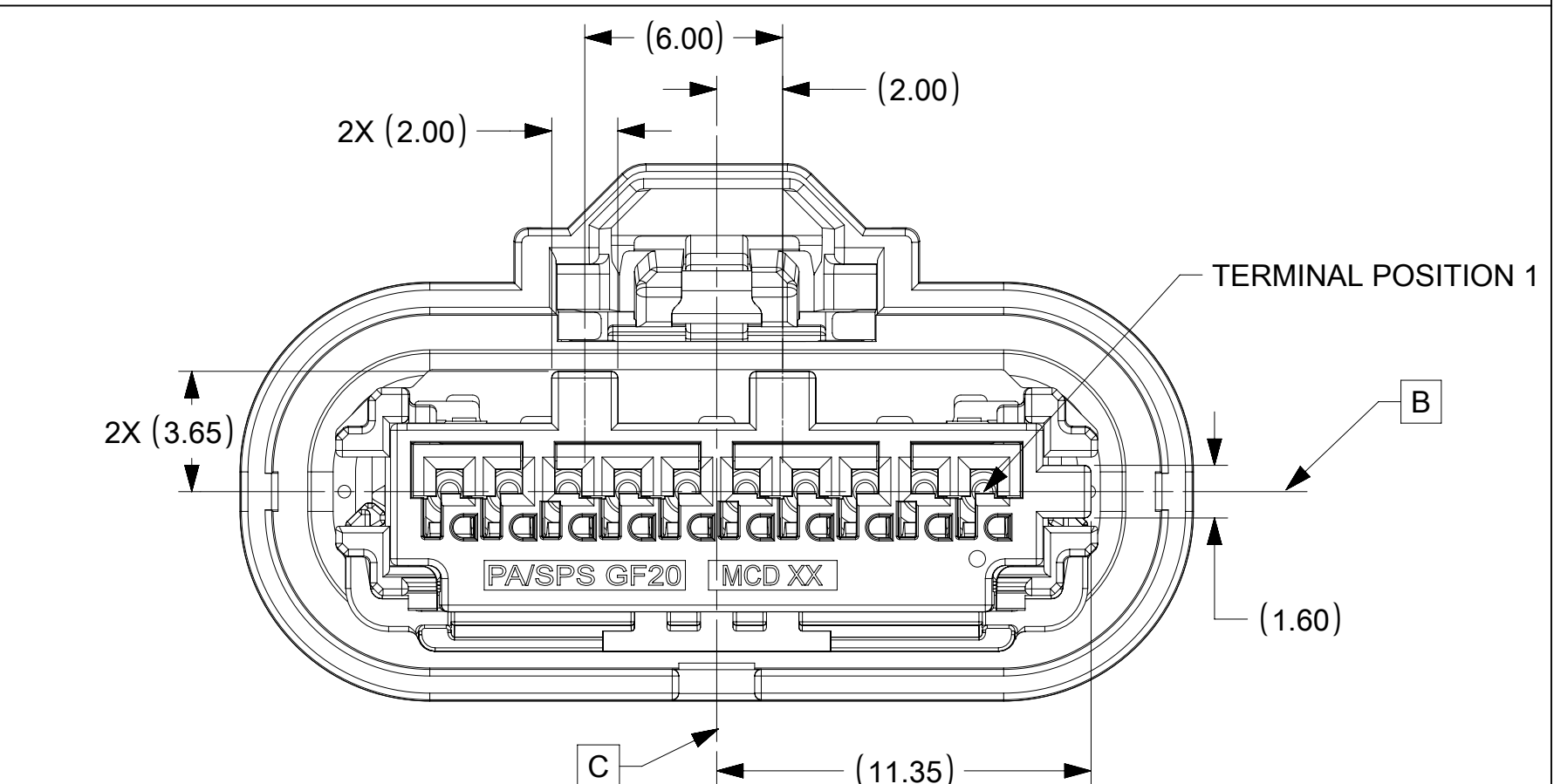

KEY C

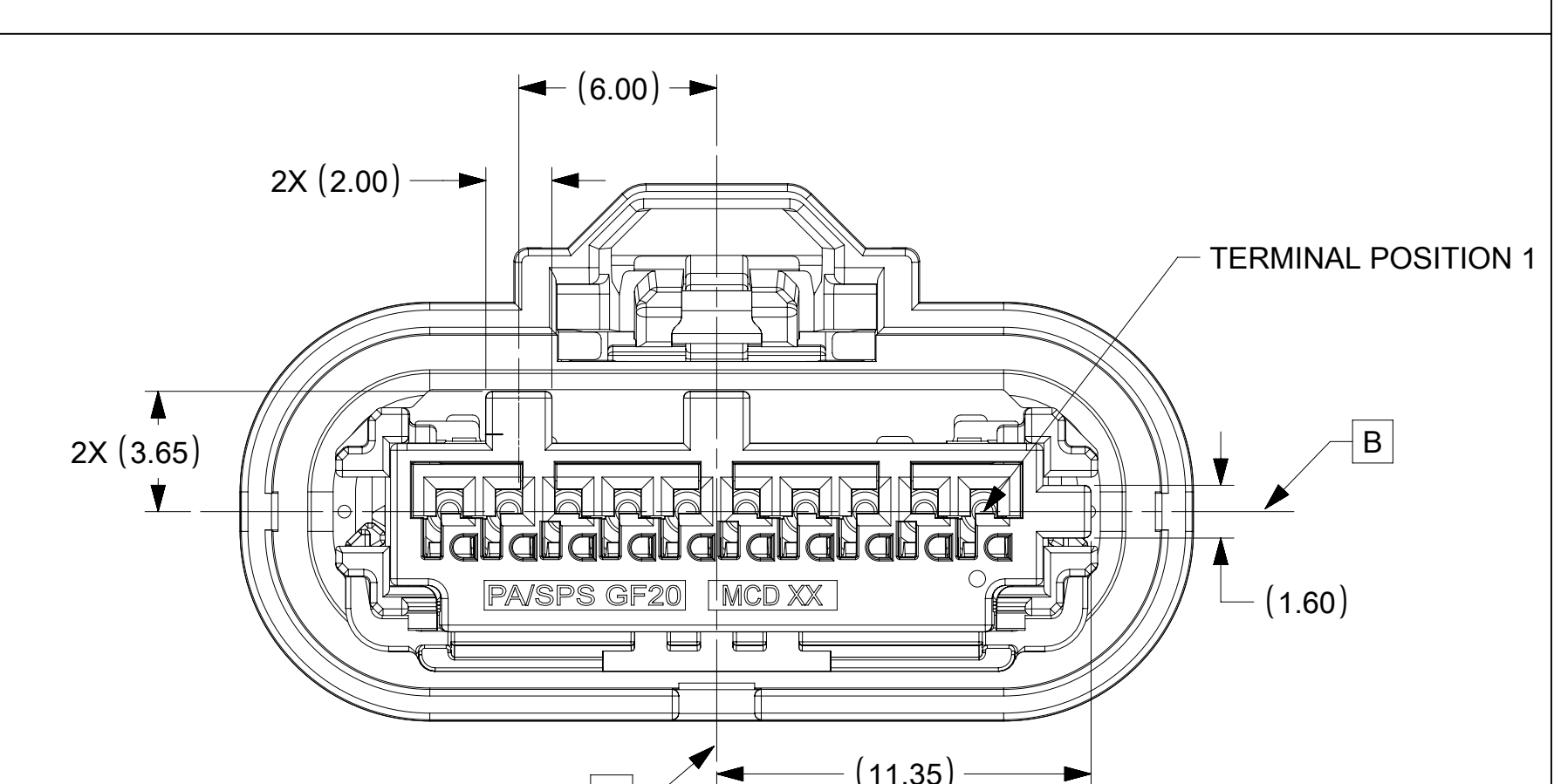

KEY D

FUNCTIONAL SYMBOLS	THIS DRAWING CONTAINS INFORMATION THAT IS PROPRIETARY TO MOLEX ELECTRONIC TECHNOLOGIES, LLC AND SHOULD NOT BE USED WITHOUT WRITTEN PERMISSION		CURRENT REV DESC: CHANGED BASIC DIMS TO REF DIMS						
	DIMENSION UNITS	SCALE							
$\frac{E}{A} = 0$	mm	1:1	GENERAL TOLERANCES (UNLESS SPECIFIED)		EC NO: 657824 DRWN: MLI149 CHK'D: JCONDON APPR: JCONDON INITIAL REVISION: DRWN: MNS02 APPR: KDEKOSKI				
$\frac{E}{C} = 0$	4 PLACES ±								
$\frac{E}{P} = 0$	3 PLACES ±								
	2 PLACES ± 0.1								
	1 PLACE ± 0.2		0 PLACES ±		2021/03/09 2021/03/11 2021/03/11 2016/04/26 2016/05/19				
DIVISIONAL SYMBOLS	DRAFT WHERE APPLICABLE MUST REMAIN WITHIN DIMENSIONS		THIRD ANGLE PROJECTION	DRAWING	SERIES	DOCUMENT NUMBER	DOC TYPE	DOC PART	REVISION
				A1-SIZE	34967	349671000	PSD	000	G1
						CUSTOMER		SHEET NUMBER	
								2 OF 3	

SHEET DESCRIPTION

RECEPTACLE CONNECTOR ASSEMBLY

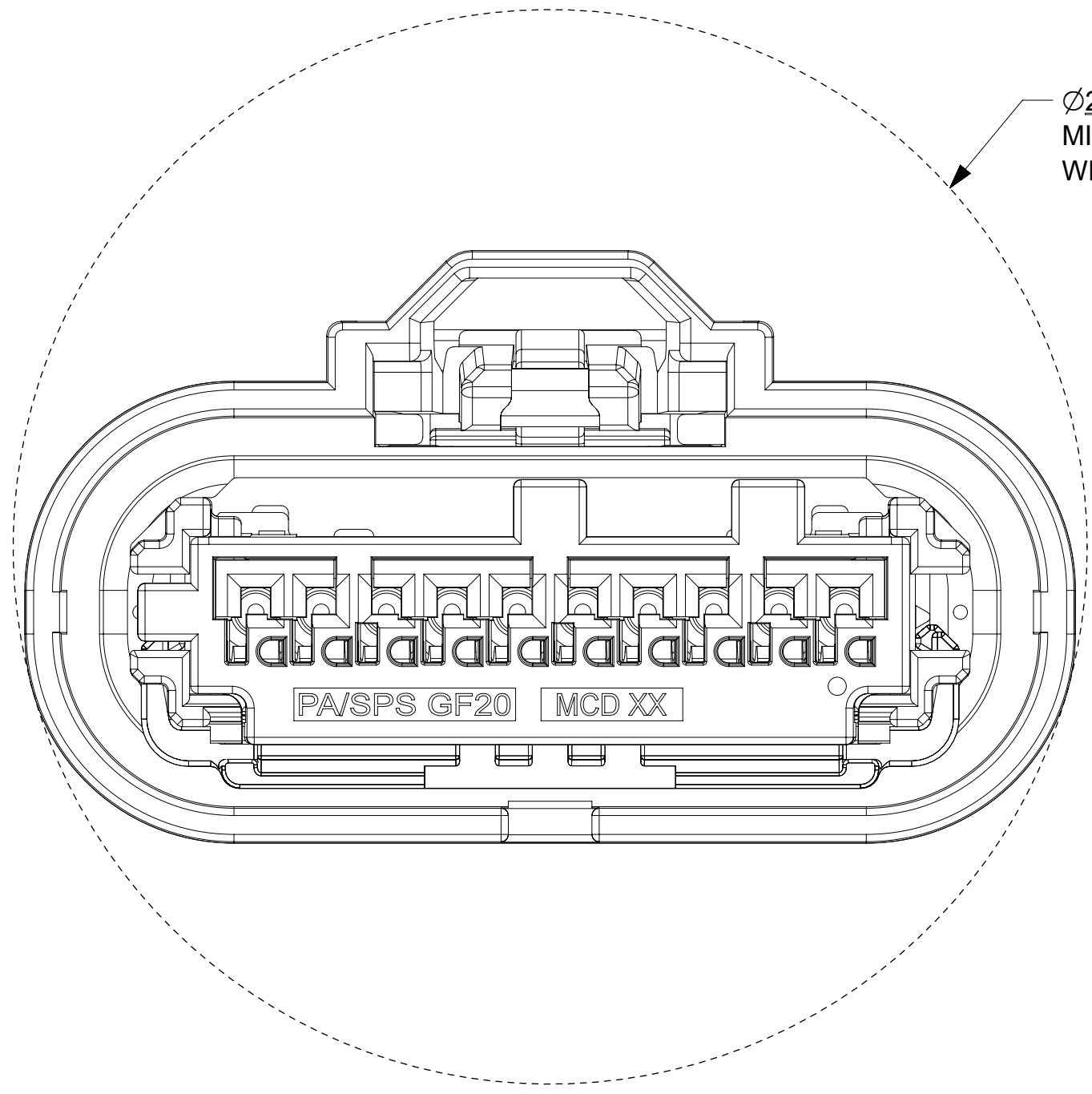

①
Ø29.44
MIN PASS-THRU
WITH NO CLEARANCE

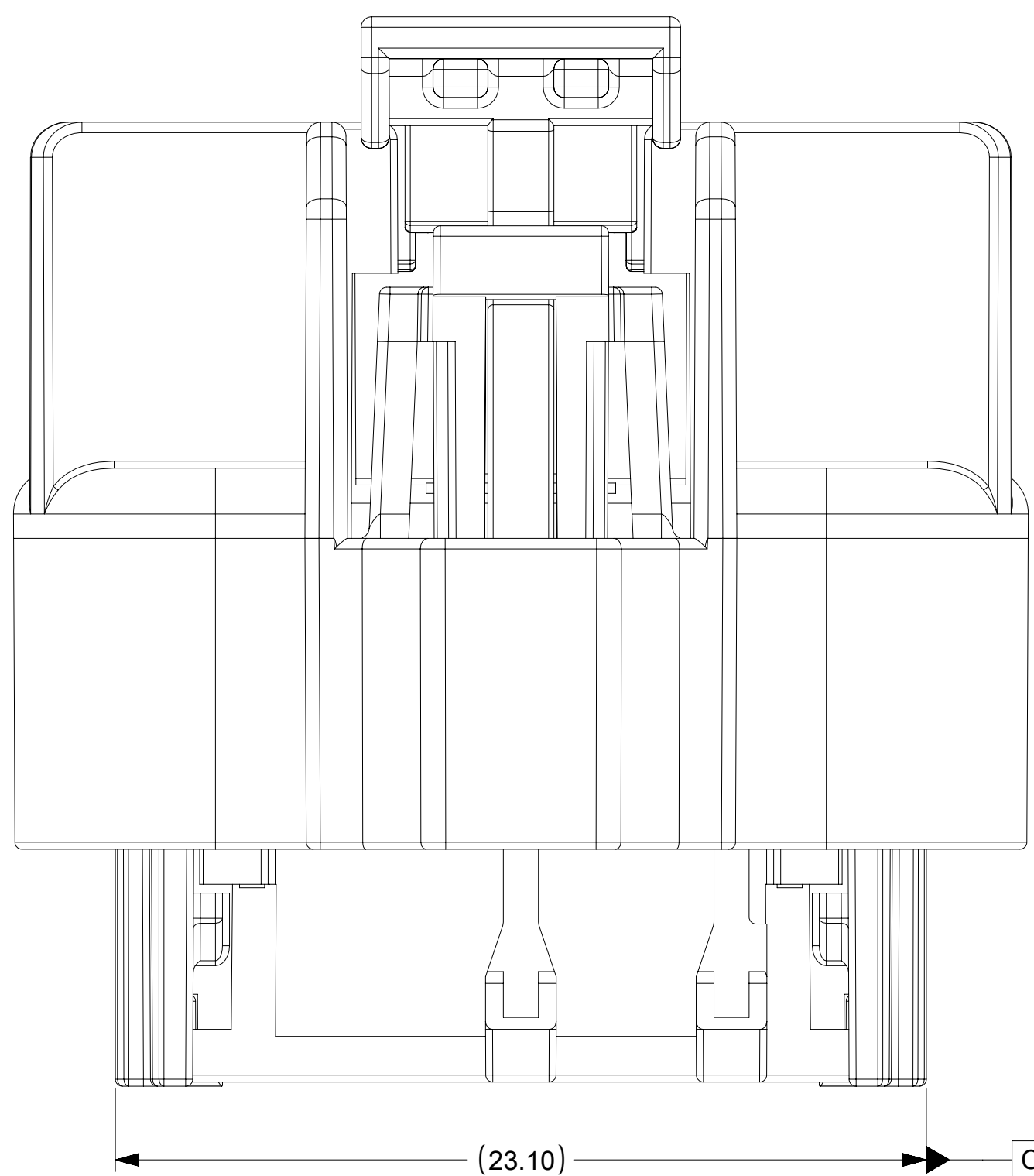

(23.10) C

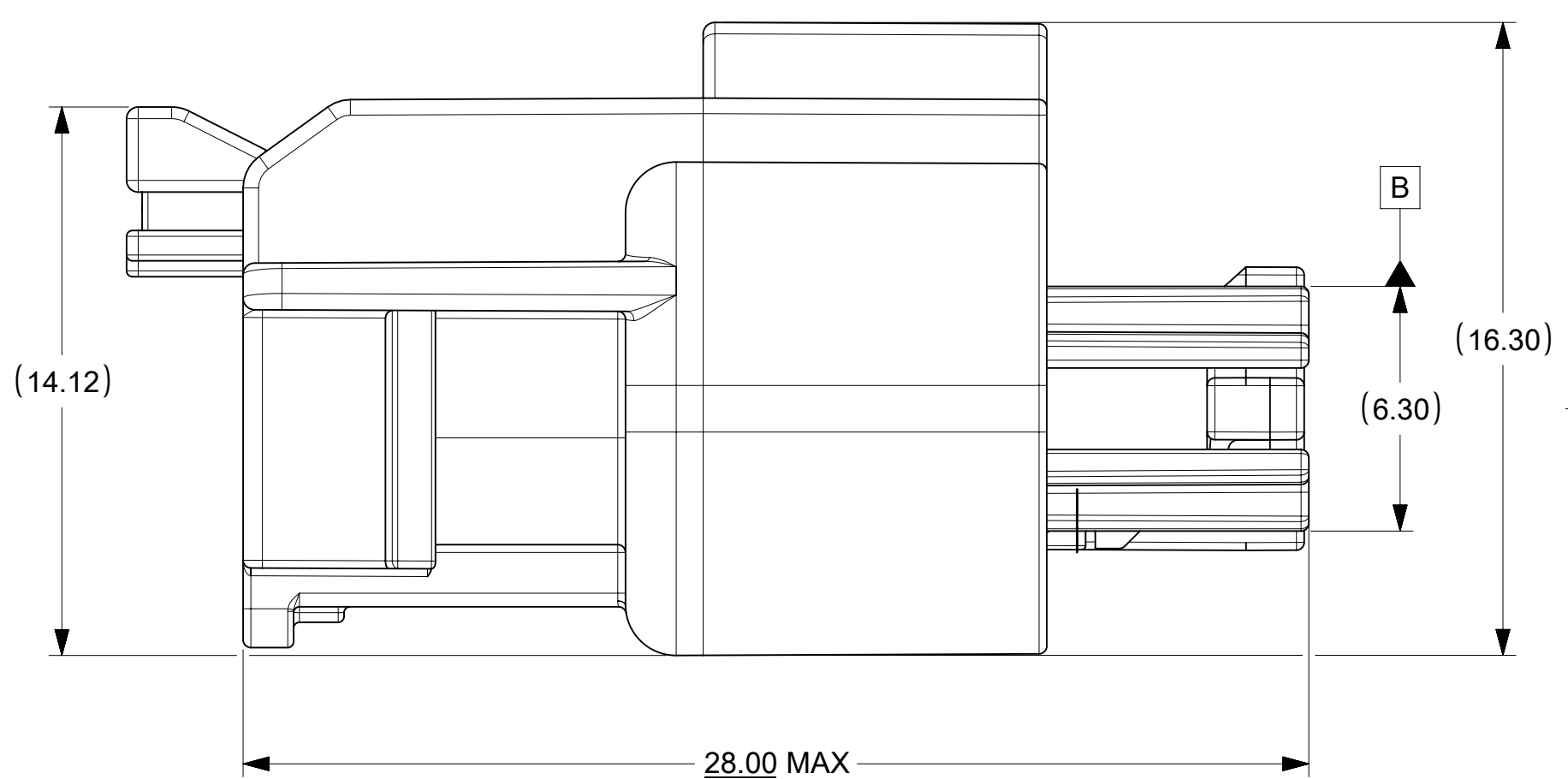

(14.12) B (16.30) (6.30) 28.00 MAX ③

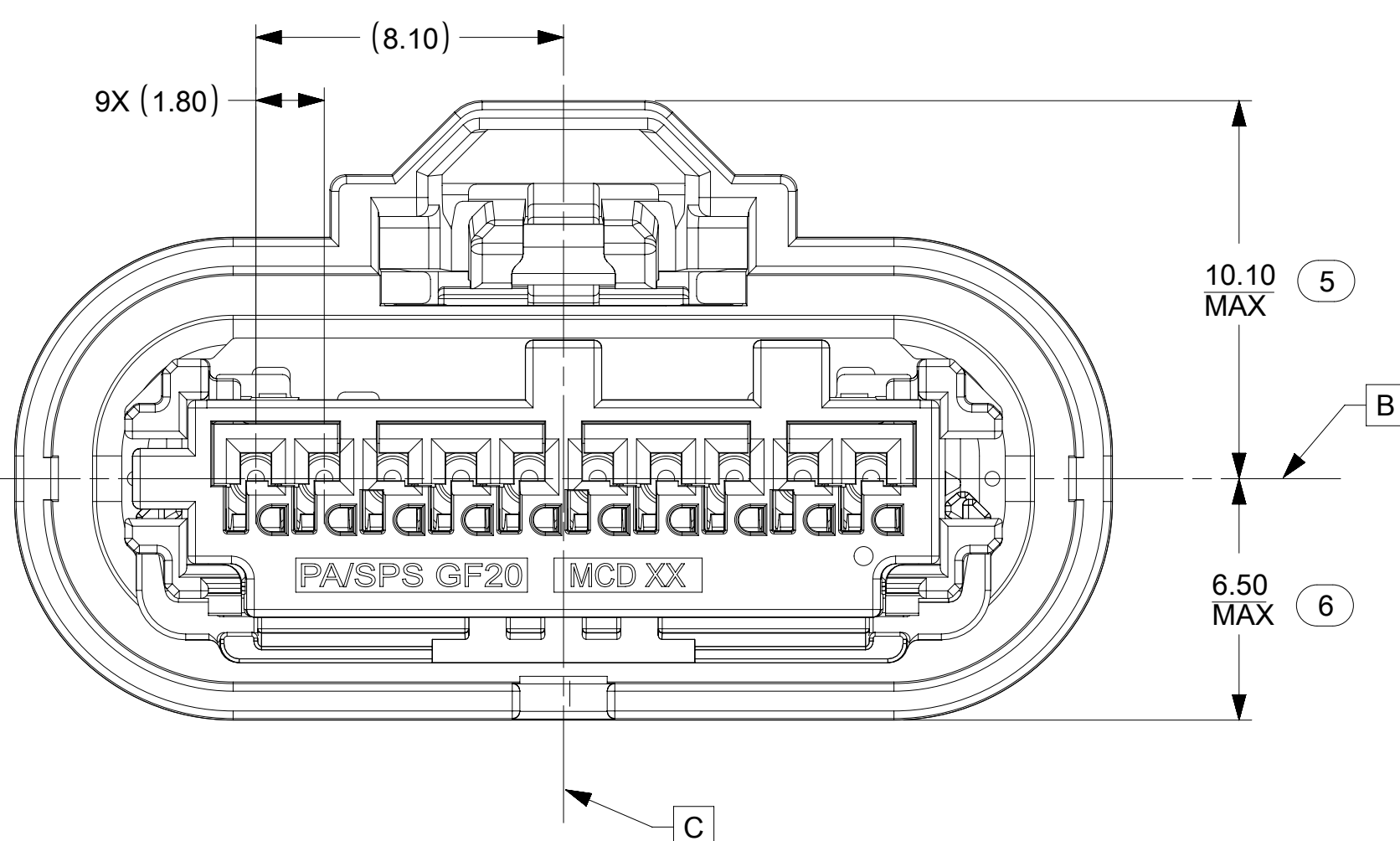

(8.10) 9X (1.80) 10.10 MAX ⑤ 6.50 MAX ⑥ C

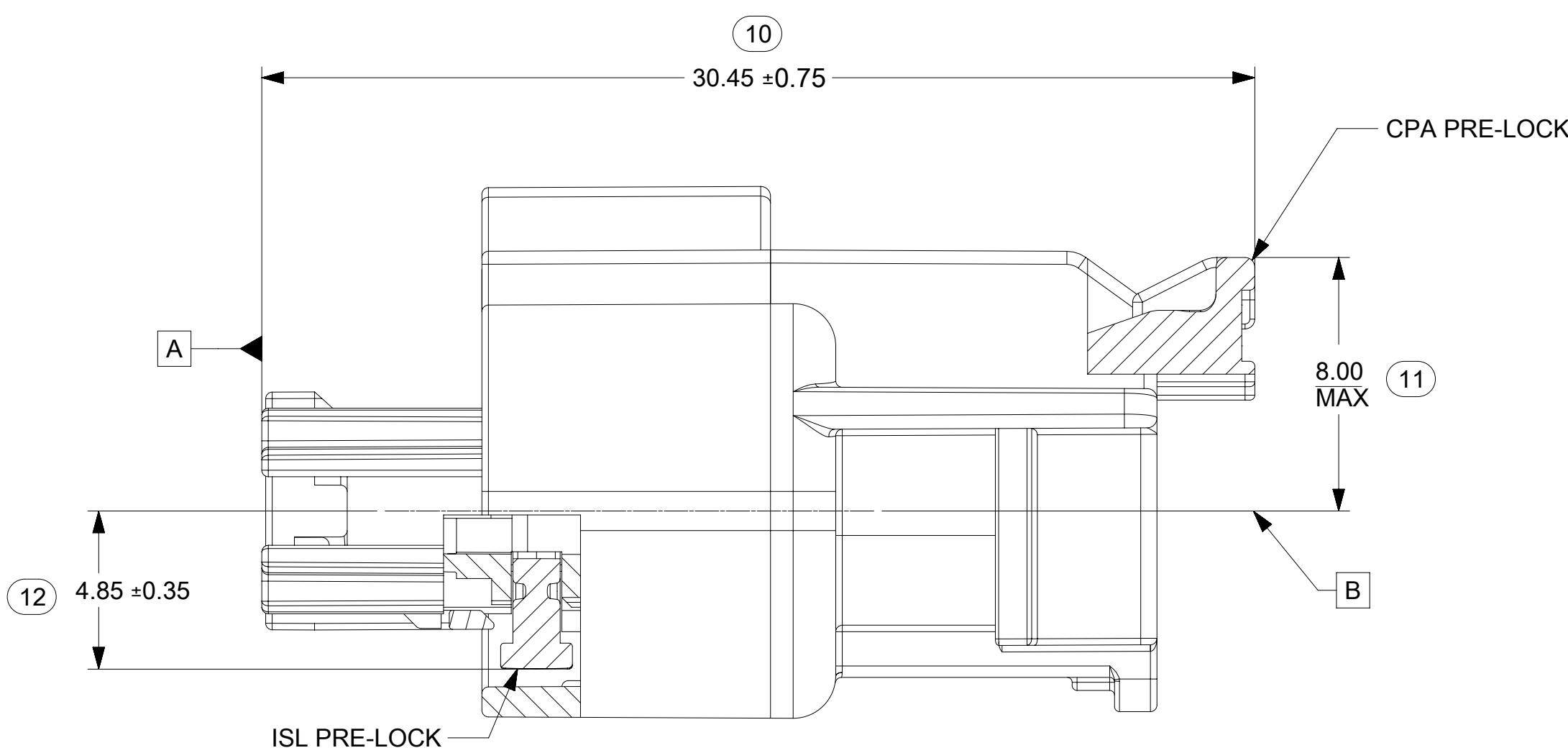

⑩ 30.45 ±0.75 CPA PRE-LOCK 8.00 MAX ⑪ 4.85 ±0.35 ⑫ ISL PRE-LOCK B

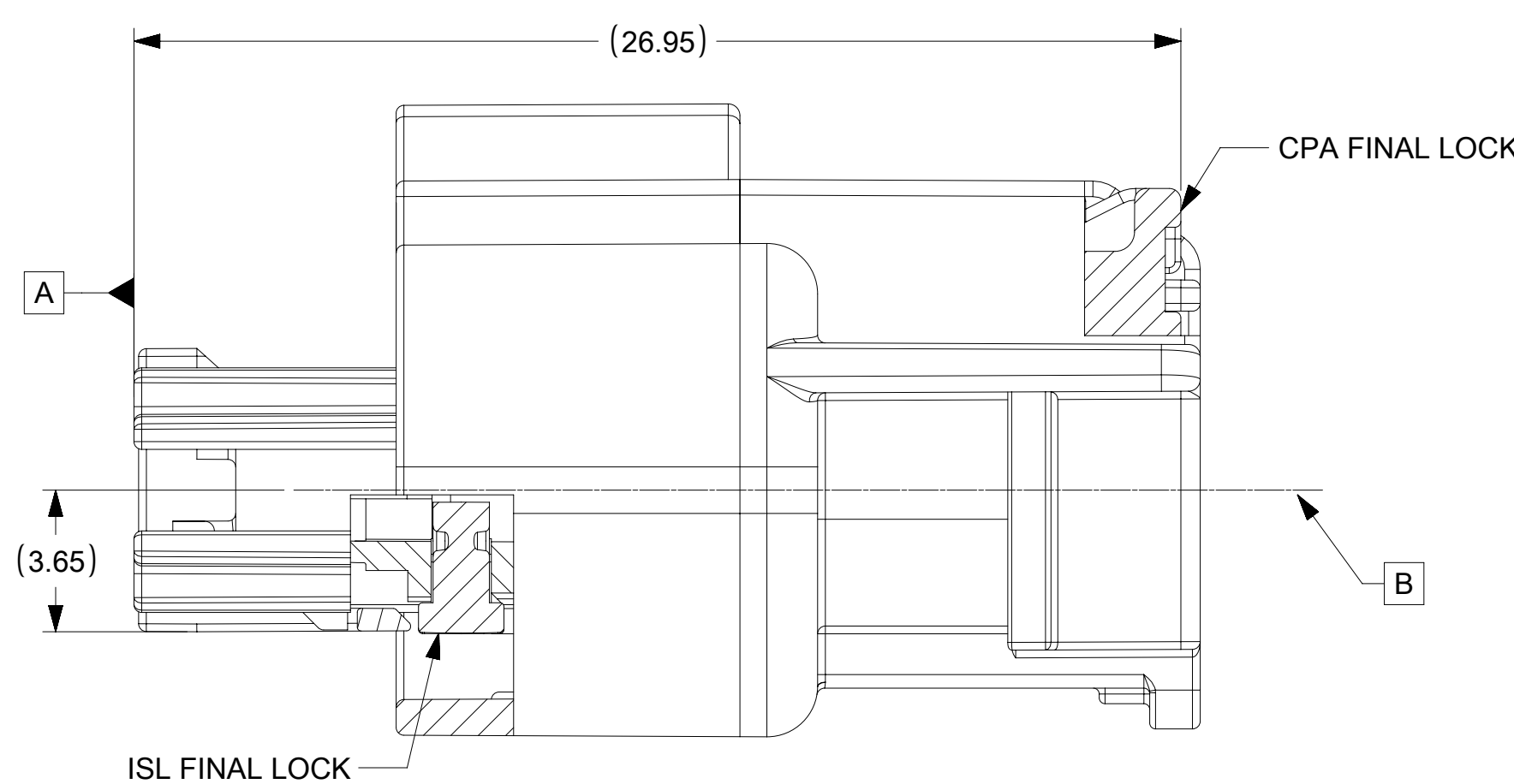

(26.95) CPA FINAL LOCK (3.65) ISL FINAL LOCK B

LASER MARKING:
PART # & DATE CODE
SEE NOTE 3g.

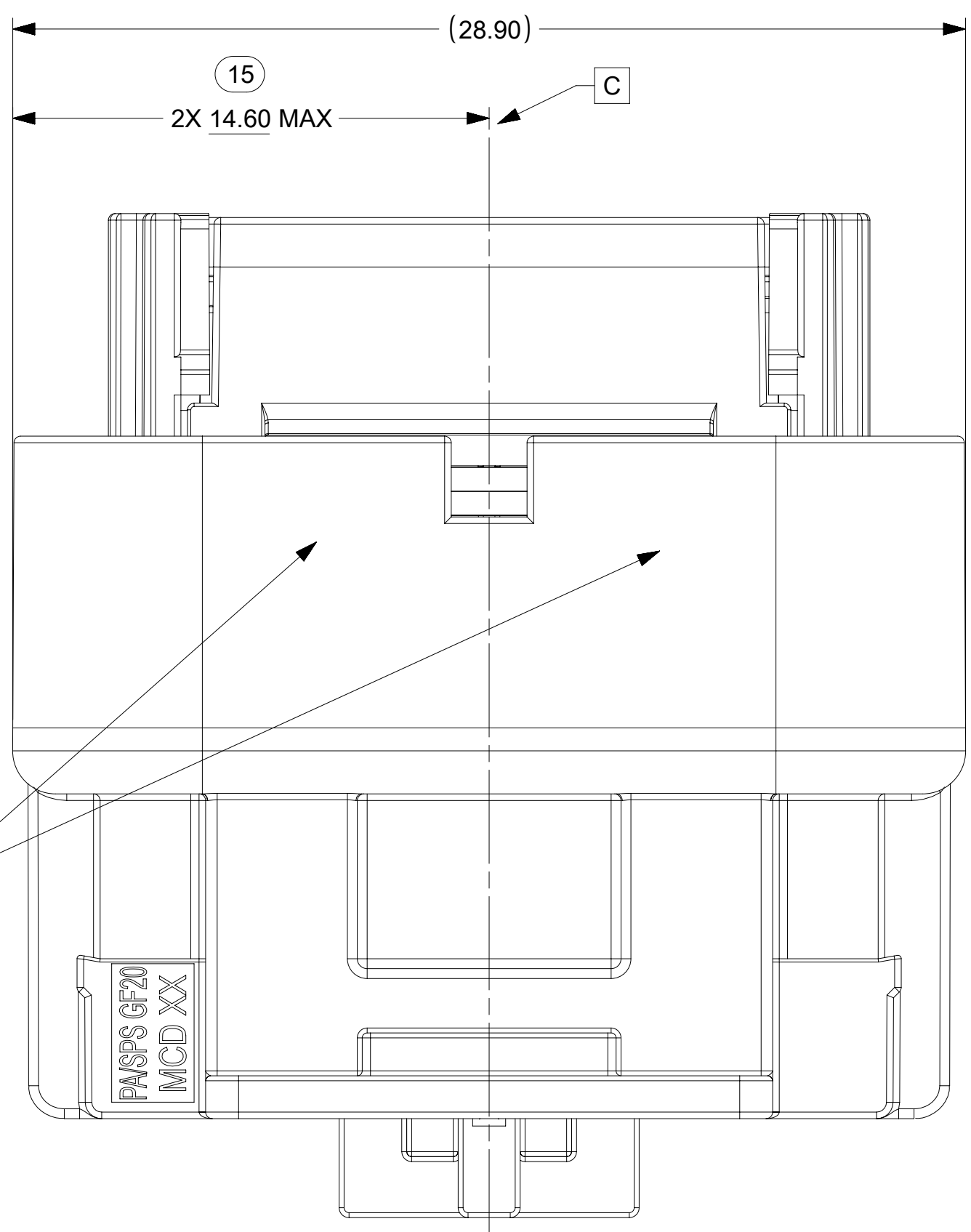

(28.90) ⑮ 2X 14.60 MAX C

FUNCTIONAL SYMBOLS FA = 0 FE = 0 FP = 0 DIVISIONAL SYMBOLS	THIS DRAWING CONTAINS INFORMATION THAT IS PROPRIETARY TO MOLEX ELECTRONIC TECHNOLOGIES, LLC AND SHOULD NOT BE USED WITHOUT WRITTEN PERMISSION		CURRENT REV DESC: CHANGED BASIC DIMS TO REF DIMS	
	DIMENSION UNITS	SCALE	EC NO: 657824	
	mm	1:1	DRWN: MLI149	2021/03/09
	GENERAL TOLERANCES (UNLESS SPECIFIED)		CHK'D: JCONDON	2021/03/11
ANGULAR TOL ± 0.3°		APPR: JCONDON	2021/03/11	
4 PLACES ±		INITIAL REVISION:		
3 PLACES ±		DRWN: MNS02	2016/04/26	
2 PLACES ± 0.1		APPR: KDEKOSKI	2016/05/19	
1 PLACE ± 0.2				
0 PLACES ±				
DRAFT WHERE APPLICABLE MUST REMAIN WITHIN DIMENSIONS		THIRD ANGLE PROJECTION	DRAWING	SERIES
			A1-SIZE	34967
DOCUMENT STATUS		DOCUMENT NUMBER	CUSTOMER	SHEET NUMBER
P1	2021/03/11 00:54:54	349671000	PSD 000	G1
		DOC TYPE	DOC PART	REVISION

molex

MINI50 SEALED 1X10 RCPT ASSY

PRODUCT CUSTOMER DRAWING

DOCUMENT NUMBER: 349671000
DOC TYPE: PSD
DOC PART: 000
REVISION: G1

MATERIAL NUMBER: 34967
CUSTOMER: 3 OF 3

TABLE OF CONTENTS	
SHEET NO.	SHEET DESCRIPTION
1	INTERFACE NOTES AND BOM
2	INTERFACE KEY CONFIGURATIONS
3	INTERFACE DEFINITION
4	INTERFACE DATUM TARGETS

MATING INTERFACE CHART			
DESCRIPTION	COLOR	MODEL NUMBER	KEY
1X10, KEY A, BLACK	BLACK	349681801	A
1X10, KEY B, LIGHT GRAY	LIGHT GRAY	349681802	B
1X10, KEY C, DARK GRAY	DARK GRAY	349681803	C
1X10, KEY D, STONE GRAY	STONE GRAY	349681804	D

NOTES: VALID UNLESS OTHERWISE SPECIFIED

1. GENERAL:

REFER TO "SAE/USCAR 12 CONNECTOR GUIDELINES" AND "SAE/USCAR 2 PERFORMANCE SPECIFICATION FOR AUTOMOTIVE ELECTRICAL CONNECTOR SYSTEMS" FOR ADDITIONAL REQUIREMENTS.

2. DESIGN - MATERIALS:

a. HOUSING: SPS/NYLON 20% GLASS FILLED OR EQUIVALENT

FLAMMABILITY REQUIREMENT: PER ISO3795 OR GM3191

1. BURN RATE 100mm/MIN MAXIMUM

2. MATERIAL MUST BE SELF EXTINGUISHING

b. BLADE TERMINAL: SEE MOLEX SALES DRAWING 347350050. FOR MATERIAL, DIMENSIONAL, PLATING

AND COATING REQUIREMENTS AND ANY BLADE TERMINAL DESIGN INFORMATION NOT SHOWN ON

REFERENCED OR THIS DRAWING SEE EWCAP DWG NO. EWCAP-001.

1. TIN PLATING: 2.5-4.0 MICROMETERS MATTE TIN OVER 1.25-2.25 MICROMETERS DUCTILE SULFAMATE NICKEL

2. SILVER PLATING: 1.9-3.3 MICROMETERS SILVER OVER 1.0-1.8 MICROMETERS DUCTILE SULFAMATE NICKEL.

ANTI-TARNISH: SYNTHETIC HYDROCARBON CONTACT SURFACE FINISH OR

EQUIVALENT APPLIED WITHOUT VOID TO CONTACT AREA

c. STANDARD COLORS FOR KEYING (SEE CHART). DEVIATION REQUIRES APPROVAL OF AUTHORIZED PERSON.

3. DESIGN - GEOMETRY:

a. THE 3-D CAD DATA IS BASIC (WITHOUT TOLERANCE) AND THE MASTER FOR THIS PART WITH THE EXCEPTION OF UNDERLINED DIMENSIONS. DIMENSIONAL INFORMATION NOT SHOWN IN THIS DRAWING IS DEFINED BY THE DATA FILE AT ITS LATEST REVISION.

b. PRODUCT DESIGN MODEL NUMBER(S): SEE MATING INTERFACE CHART

c. GEOMETRIC DIMENSIONS AND TOLERANCES PER ASME Y14.5M - 2009

d. GENERAL TOLERANCES: SEE TITLE BLOCK

e. EDGES AND UNDIMENSIONED DETAILS PER ISO13715

f. CORNERS SHOWN AS SHARP TO BE R 0.2 MAX.

g. LETTERING SHALL BE 0.15 MAX RAISED IN 0.25 MAX RECESS PAD.

THIS INCLUDES RECYCLING CODE, CAVITY ID, VENDOR IDENTIFICATION,

AND CUSTOMER MATERIAL NUMBER.

(FOR SMALL PARTS: LETTERING SHALL BE 0.10 MAX RAISED IN 0.15 MAX RECESS PAD)

4. DESIGN - MANUFACTURING:

a. ALLOWABLE FLASH MAX 0.20 HIGH BY MAX 0.13 THICK.

b. ALLOWABLE SPLIT/PARTING LINE MISMATCH 0.2 MAX.

c. EJECTOR PIN MARKS TO BE FLUSH TO 0.25 MAX DEPRESSED. LOCATION MUST BE APPROVED BY PRODUCT ENGINEERING. EJECTOR PIN MARKS NOT PERMISSIBLE ON OR NEAR DATUM TARGET AREA.

d. ALLOWABLE GATE VESTIGE FLUSH TO 0.25 MAX RECESS. LOCATION

MUST BE APPROVED BY PRODUCT ENGINEERING.

e. NO EXTERNAL MOLD RELEASE AGENT ALLOWED DURING MANUFACTURING.

f. NO PARTING LINES, MISMATCHES OR EJECTOR MARKS PERMISSIBLE WITHIN THE INDICATED SURFACE. TOOLING FOR INDICATED SURFACE MUST BE PROCESSED TO A SURFACE FINISH OF NTMA #70 (400 PAPER)

g. BLADE TERMINAL ENVIRONMENTAL BARRIER (USED WITH SILVER PLATED TERMINALS) SHALL NOT BE PRESENT ON ANY SURFACE OTHER THAN THE BLADE TERMINALS

h. NO PARTING LINES, FLASH, MISMATCHES OR EJECTOR MARKS PERMISSIBLE ON THE INDICATED NOSE SURFACE OR TRANSITION TO INTERNAL SHROUD SURFACE.

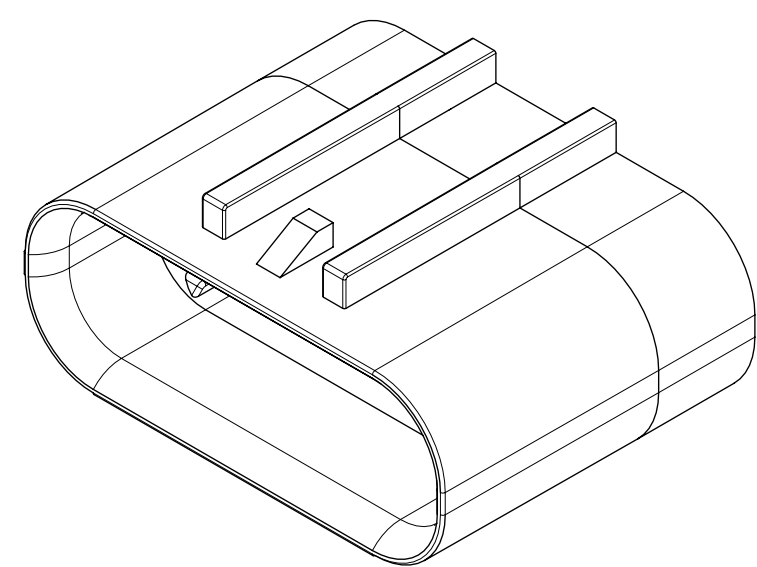

1X10

INSPECTION NUMBER LOG	
LAST NUMBER: ICD-30	
ADDED:	
REMOVED: ICD-27A	

D1	REMOVED ICD-27A. CHANGED ICD-12 AND ICD-28
D	CHANGED RIB REMOVAL FOR KEYING: SEE VIEWS SHEET 2. ADDED SEE NOTE 2 TO PIN DETAIL SHEET 3. REVISED NOTE 4f.
C1	REVISED NOTES AND DIMENSIONS
C	RELEASE
REV	REV DESCRIPTION

QUALITY SYMBOLS FA = 0 FE = 0 FE = 0 ▽ = 0 C = 0 ☒ = 0 ■ = 0 ▽ = 0	THIS DRAWING CONTAINS INFORMATION THAT IS PROPRIETARY TO MOLEX ELECTRONIC TECHNOLOGIES, LLC AND SHOULD NOT BE USED WITHOUT WRITTEN PERMISSION					
	EC NO: 659036 DRWN: ML1149 CHKD: JCONDON APPR: JCONDON	2021/02/26 2021/03/24 2021/03/24	GENERAL TOLERANCES (UNLESS SPECIFIED) DIMENSION UNITS: mm SCALE: 1:1 DRWN BY: MNS02 DATE: 2016/04/21 CHK'D BY: [blank] DATE: [blank]	APPR BY: KDEKOSKI DATE: 2016/05/04		PRODUCT CUSTOMER DRAWING
	4 PLACES ± 3 PLACES ± 2 PLACES ± 0.1 1 PLACE ± 0.2 0 PLACES ±	ANGULAR TOL ± 3.0 ° DRAFT WHERE APPLICABLE MUST REMAIN WITHIN DIMENSIONS	DRAWING SIZE: A1 THIRD ANGLE PROJECTION	SERIES: 34968 MATERIAL NUMBER: SEE CHART CUSTOMER: [blank]		DOCUMENT NUMBER: 349681800 DOC TYPE: PSD DOC PART: 000 SHEET NUMBER: 1 OF 4
	RELEASE STATUS: P1 RELEASE DATE: 2021/03/24 15:08:37					

SHEET DESCRIPTION
CONNECTOR INTERFACE DEFINITION

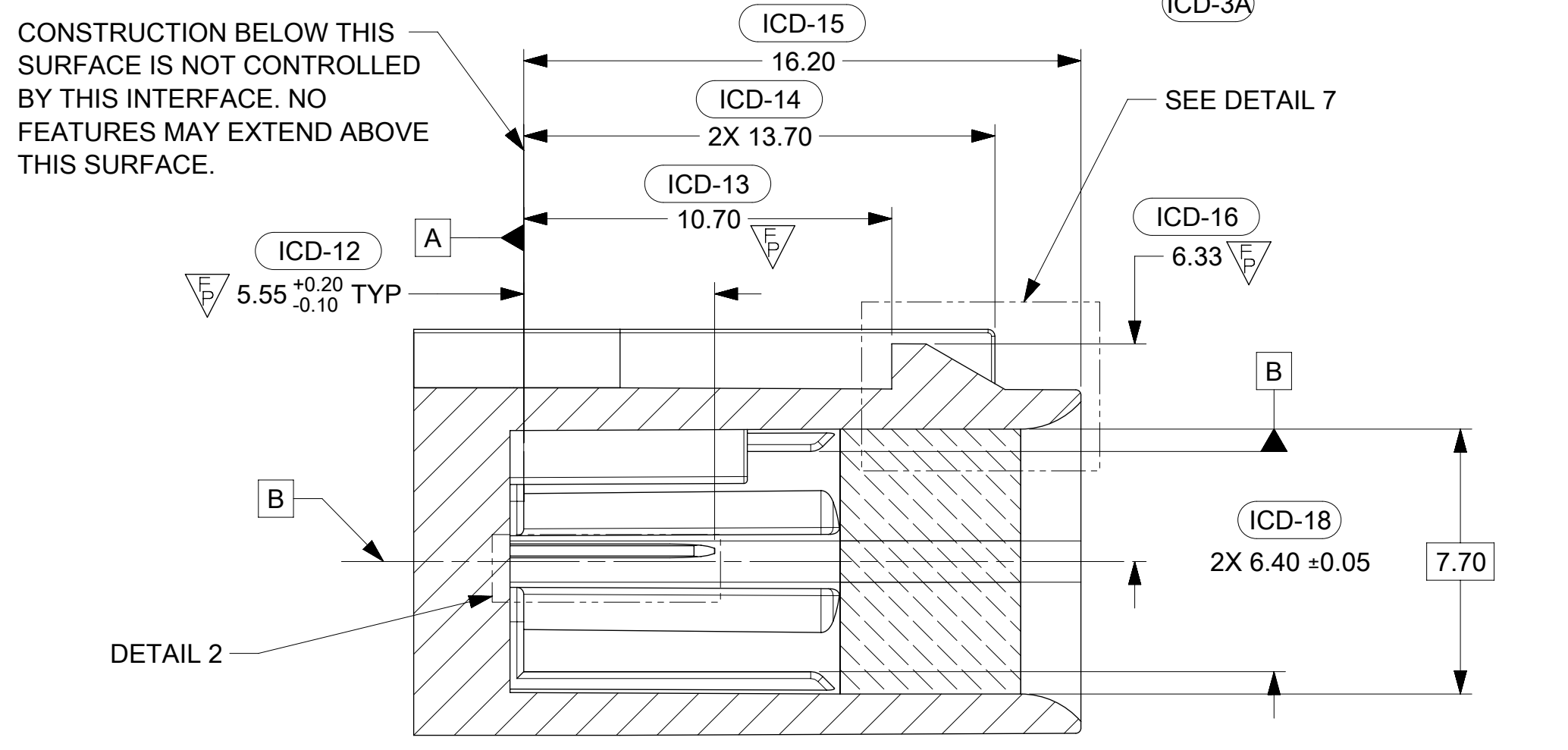
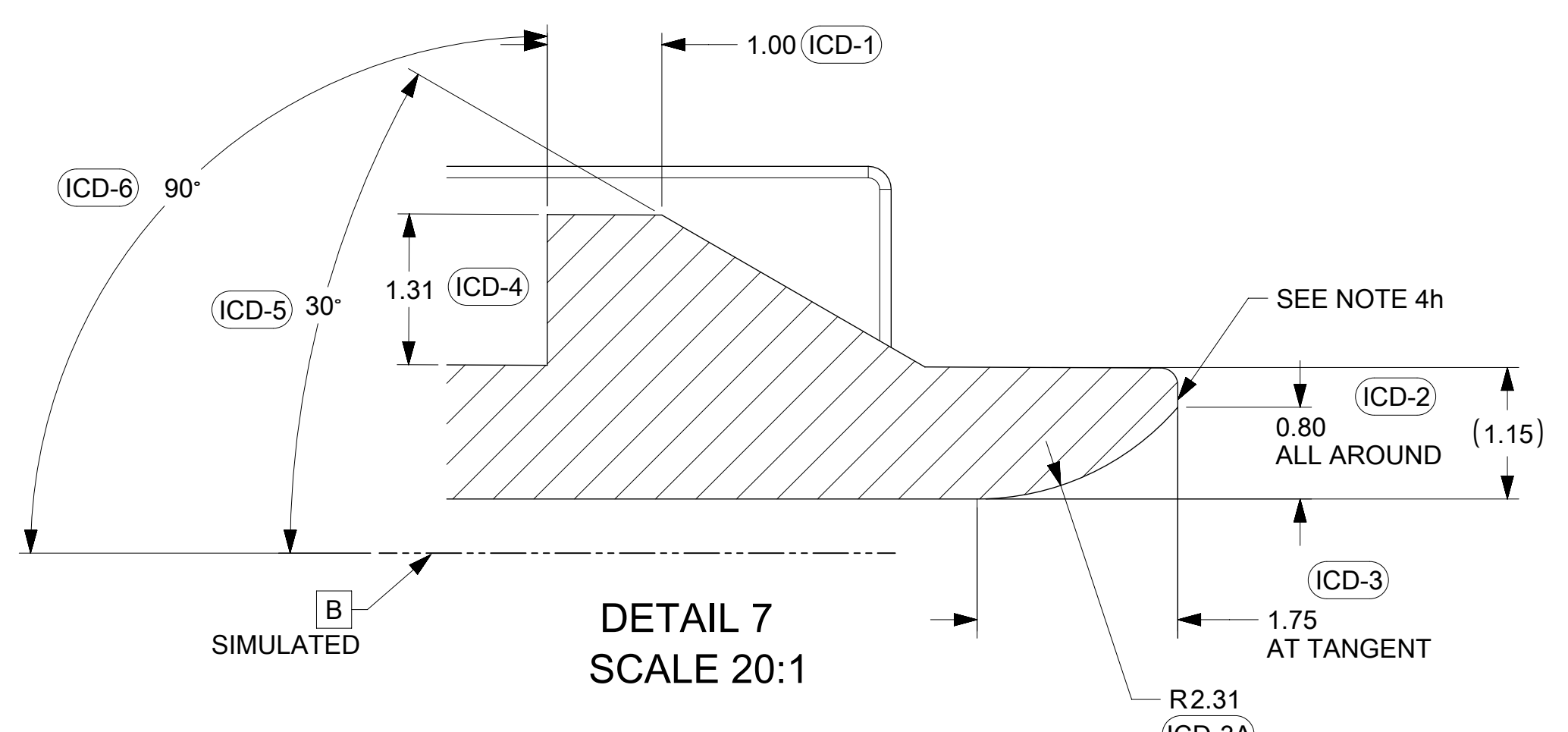

SECTION V-V

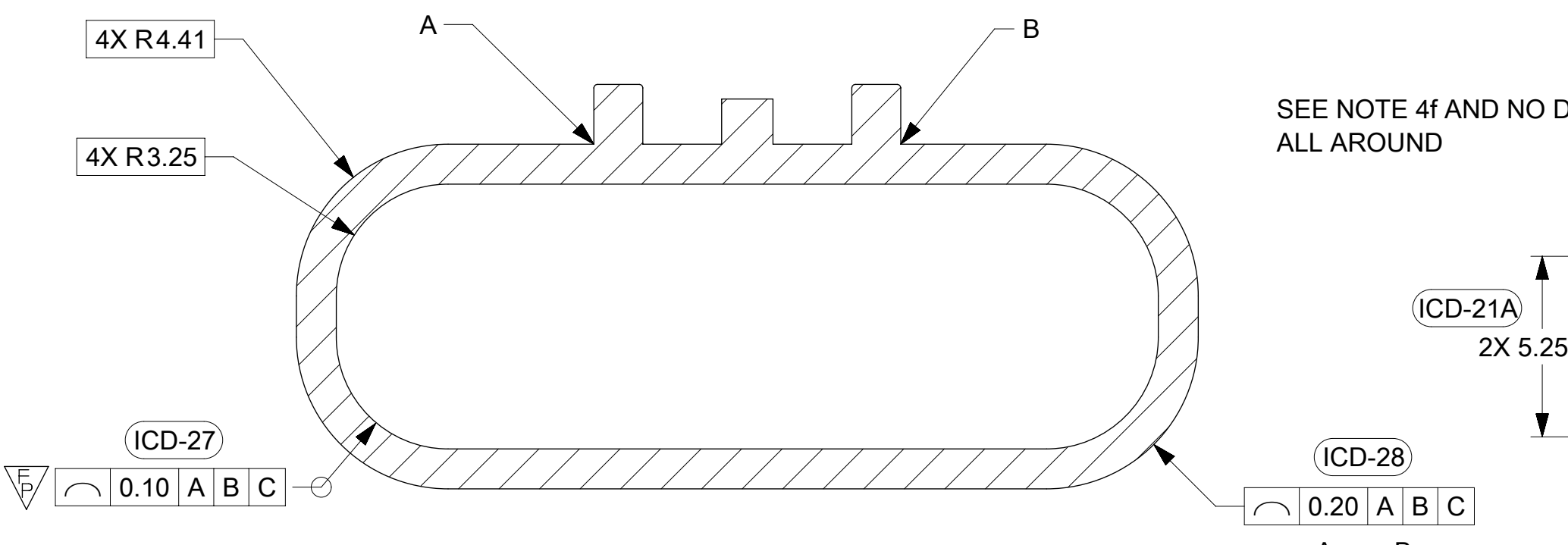

SECTION S-S
SCALE 10:1

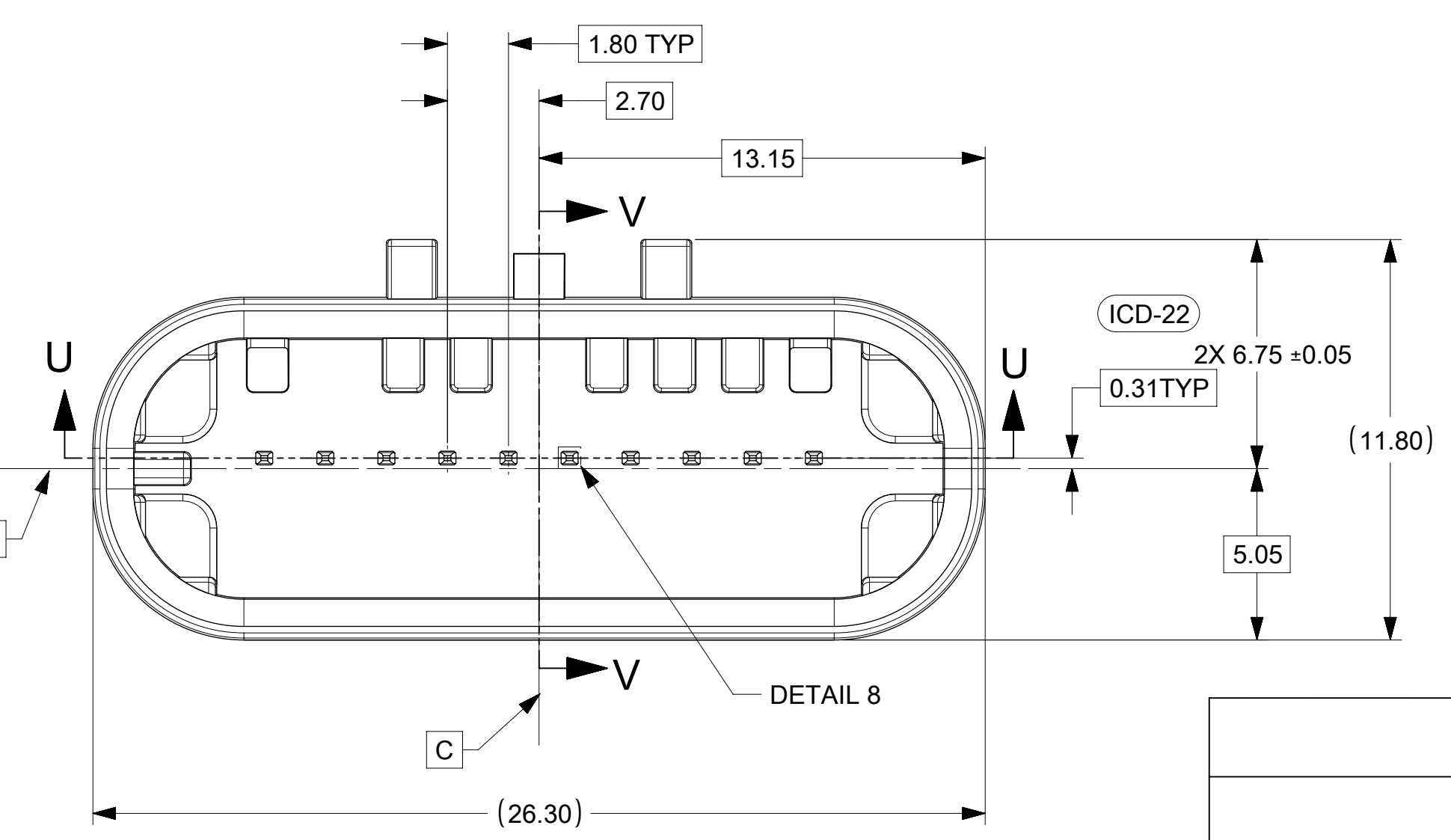
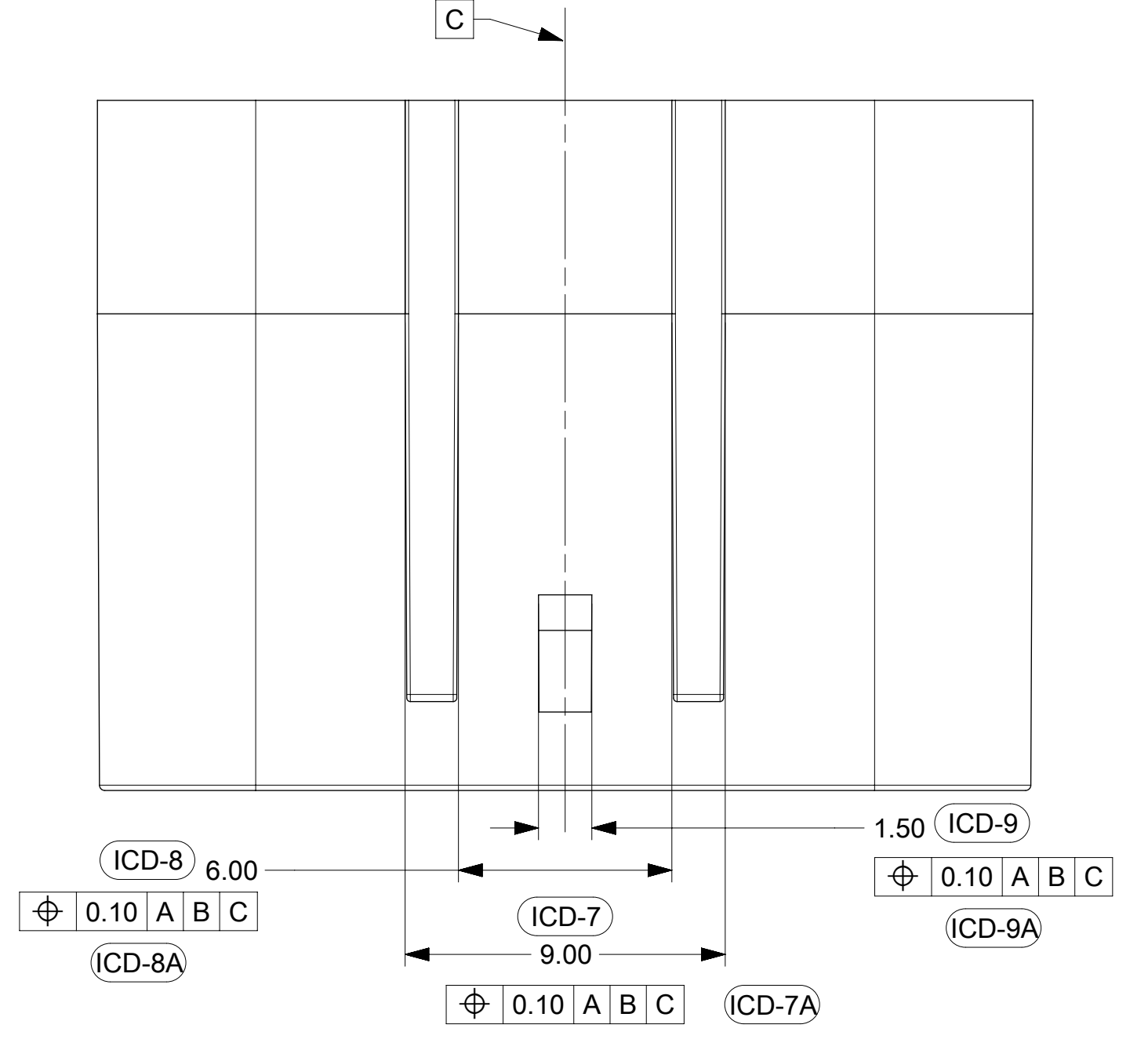

SECTION U-U

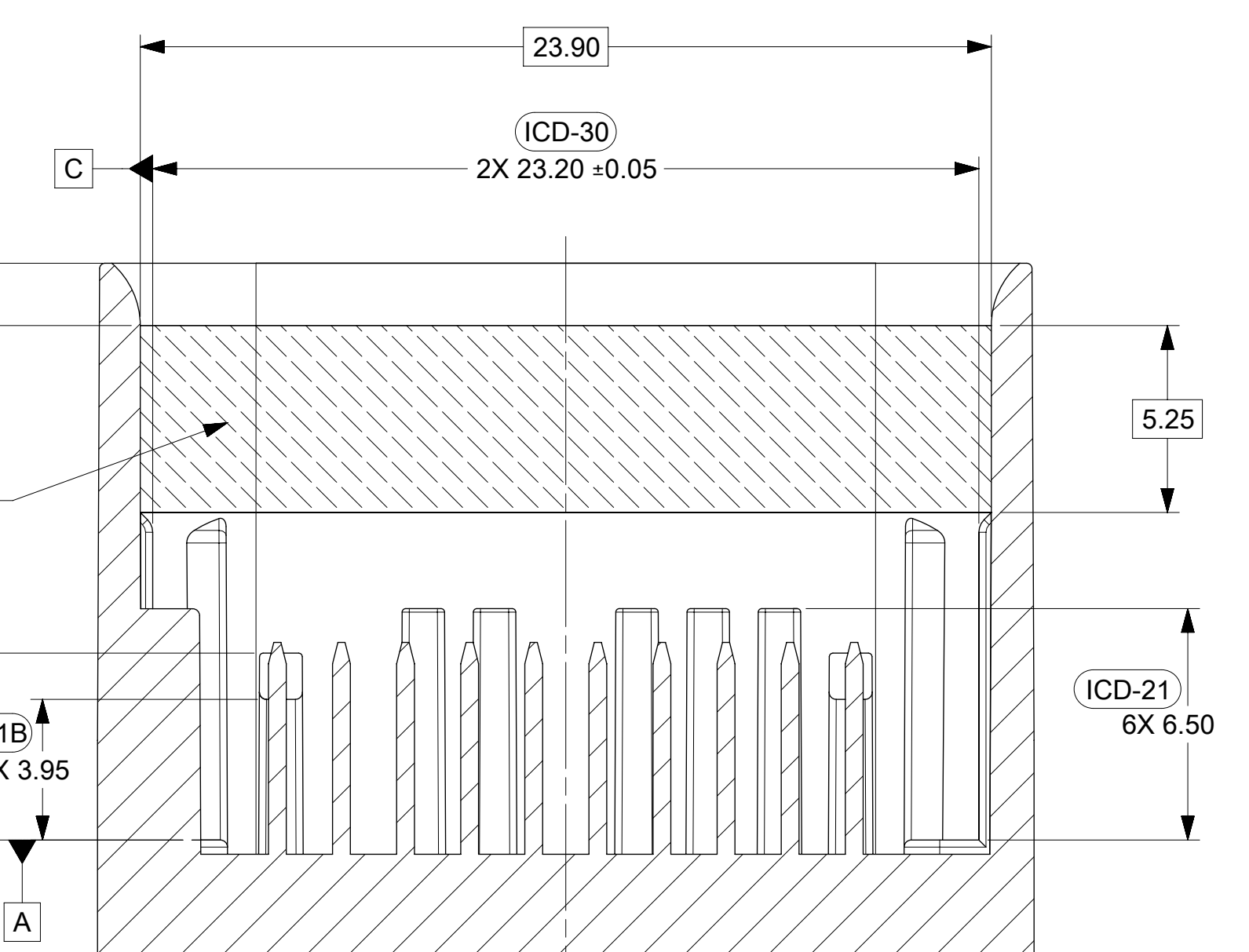

SECTION W-W

SEE NOTE 2
REFER TO MOLEX SALES DWG 347350050
AND EWCAP DWG. NO. EWCAP-001 REV. P 050-T001
0.50 TERMINAL BLADE CONFIGURATION

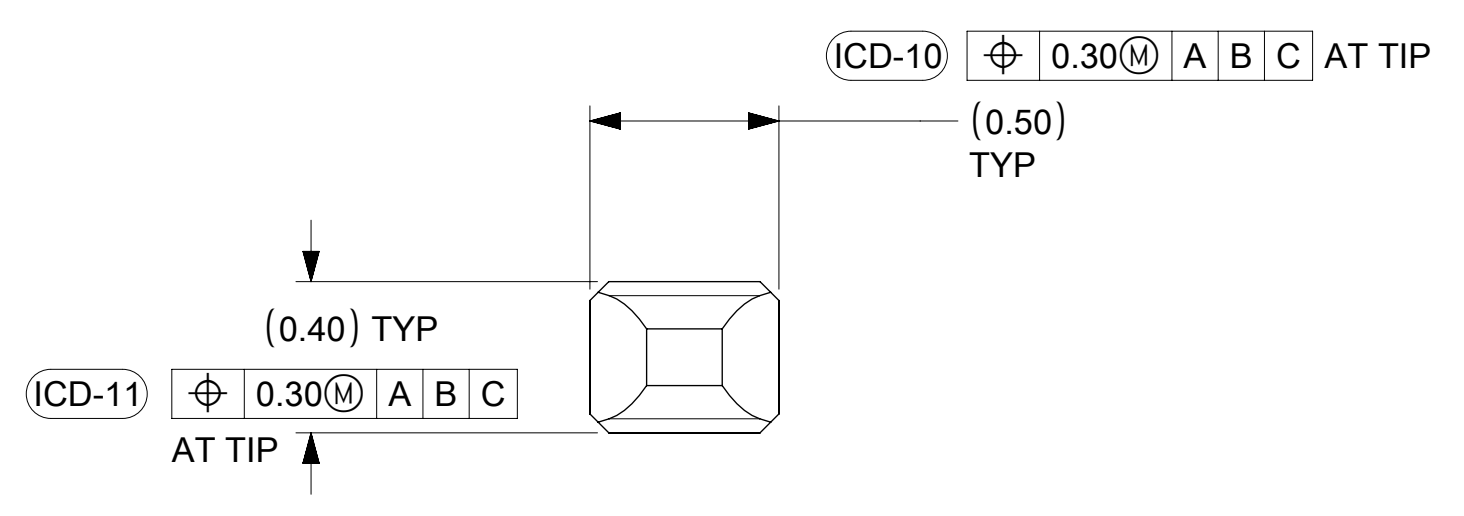

DETAIL 8
SCALE 50:1

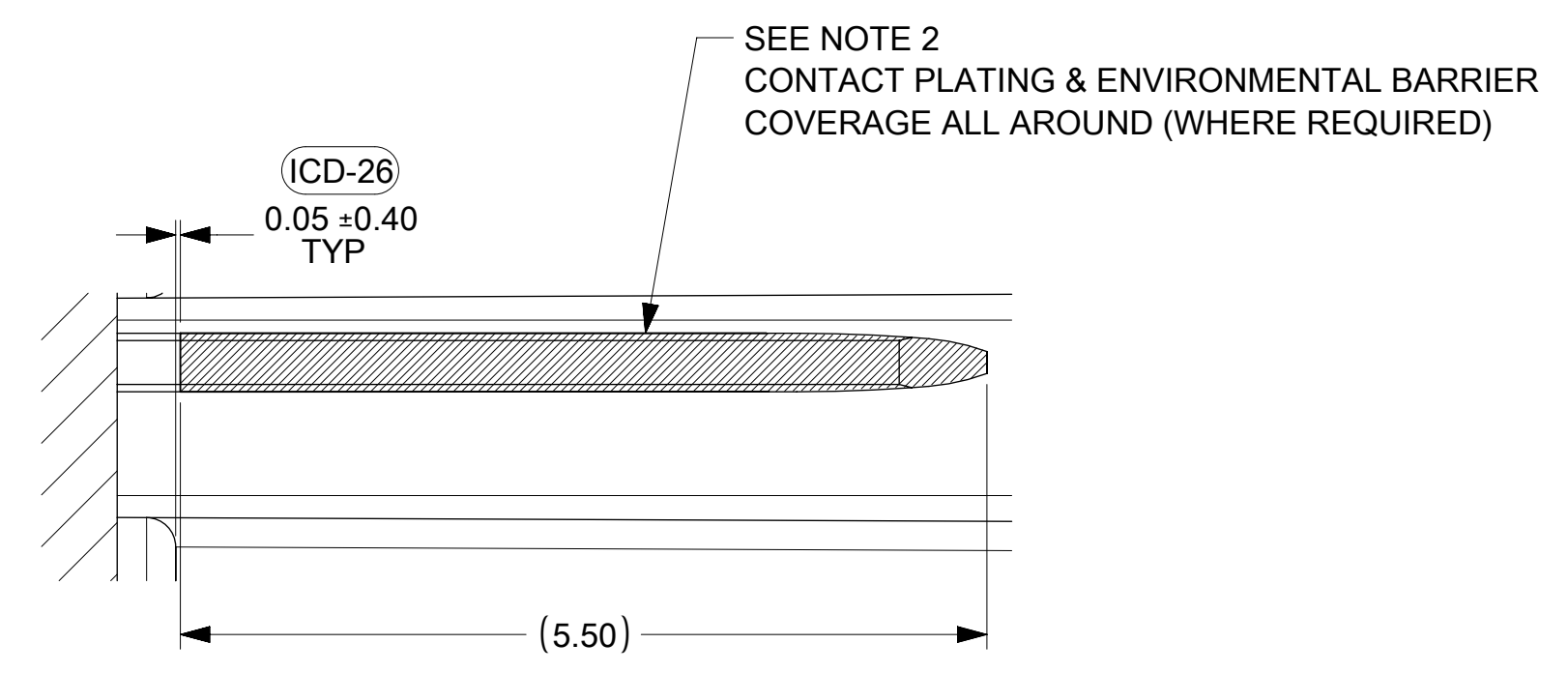

DETAIL 2
SCALE 20:1

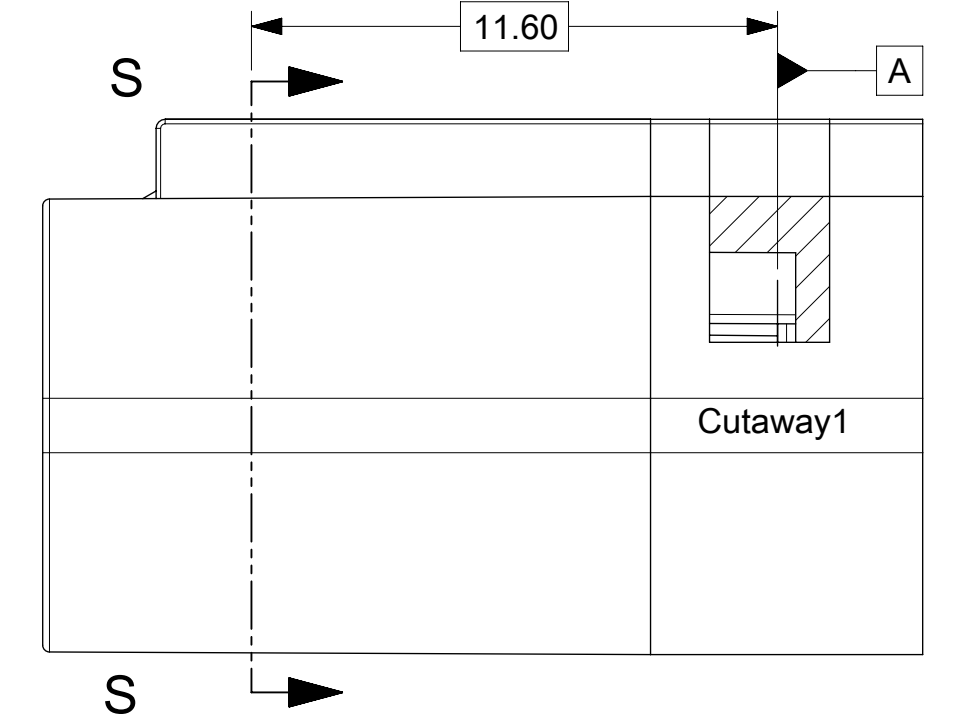

PACKAGING FRAME

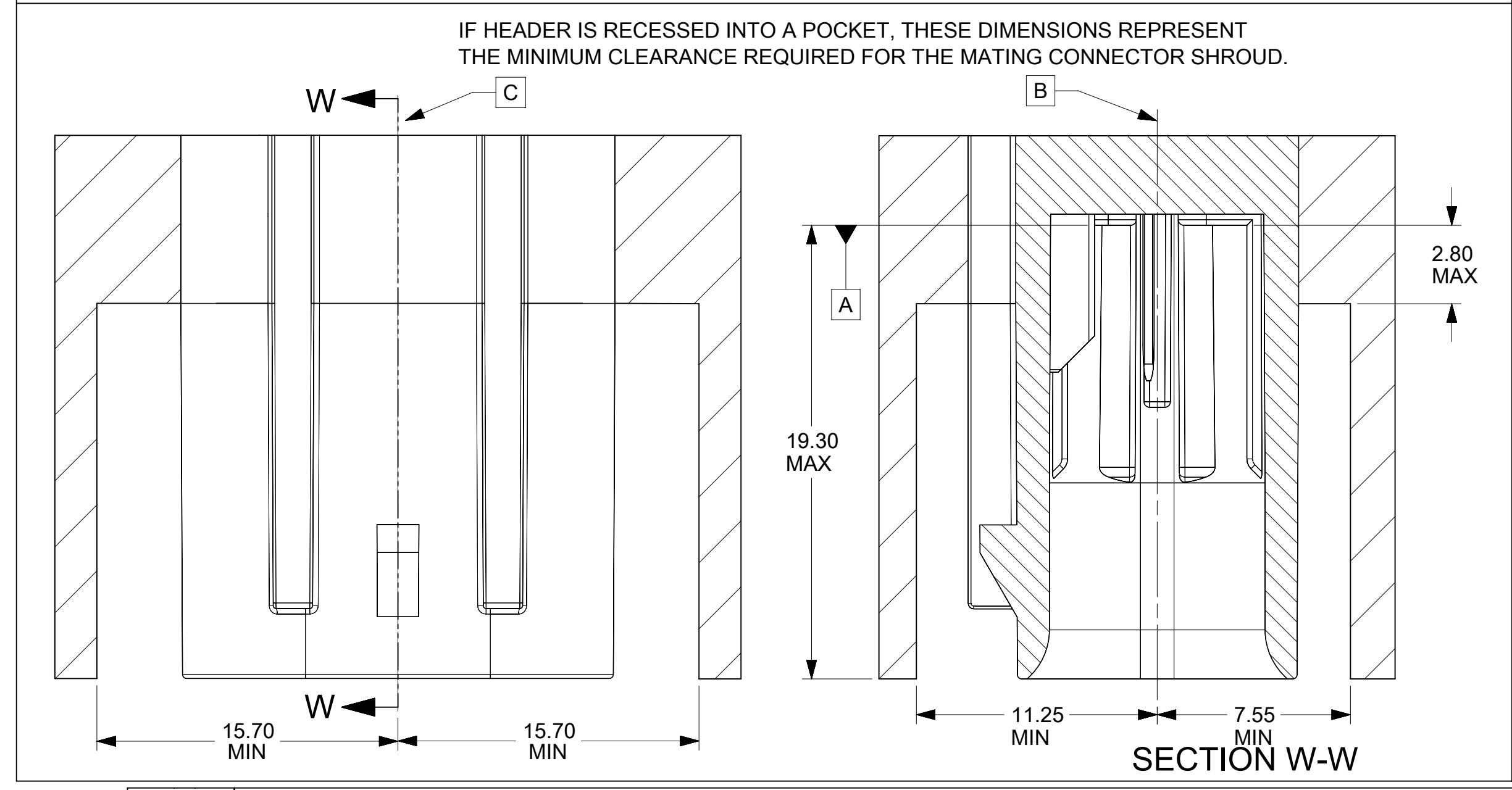

QUALITY SYMBOLS F = 0 F = 0 F = 0 ▽ = 0 C = 0 ⊠ = 0 ■ = 0 ▽ = 0	THIS DRAWING CONTAINS INFORMATION THAT IS PROPRIETARY TO MOLEX ELECTRONIC TECHNOLOGIES, LLC AND SHOULD NOT BE USED WITHOUT WRITTEN PERMISSION				
	EC NO: 659036 DRWN: ML149 CHKD: JCONDON REV APPR: JCONDON	2021/02/26 2021/03/24 2021/03/24	GENERAL TOLERANCES (UNLESS SPECIFIED) ANGULAR TOL ± 3.0 ° 4 PLACES ± 3 PLACES ± 2 PLACES ± 0.1 1 PLACE ± 0.2 0 PLACES ± DRAFT WHERE APPLICABLE MUST REMAIN WITHIN DIMENSIONS	DIMENSION UNITS: mm SCALE: 1:1 DRWN BY: MNS02 DATE: 2016/04/21 CHK'D BY: DATE: APPR BY: KDEKOSKI DATE: 2016/05/04 DRAWING SIZE: A1 THIRD ANGLE PROJECTION	
	MINI50 SEALED 1X10 INTERFACE			PRODUCT CUSTOMER DRAWING	
	SERIES: 34968 MATERIAL NUMBER: SEE CHART CUSTOMER:	DOCUMENT NUMBER: 349681800 DOC TYPE: PSD DOC PART: 000 SHEET NUMBER: 3 OF 4			
	RELEASE STATUS: P1 RELEASE DATE: 2021/03/24 15:08:37				

SHEET DESCRIPTION
DATUM TARGETS

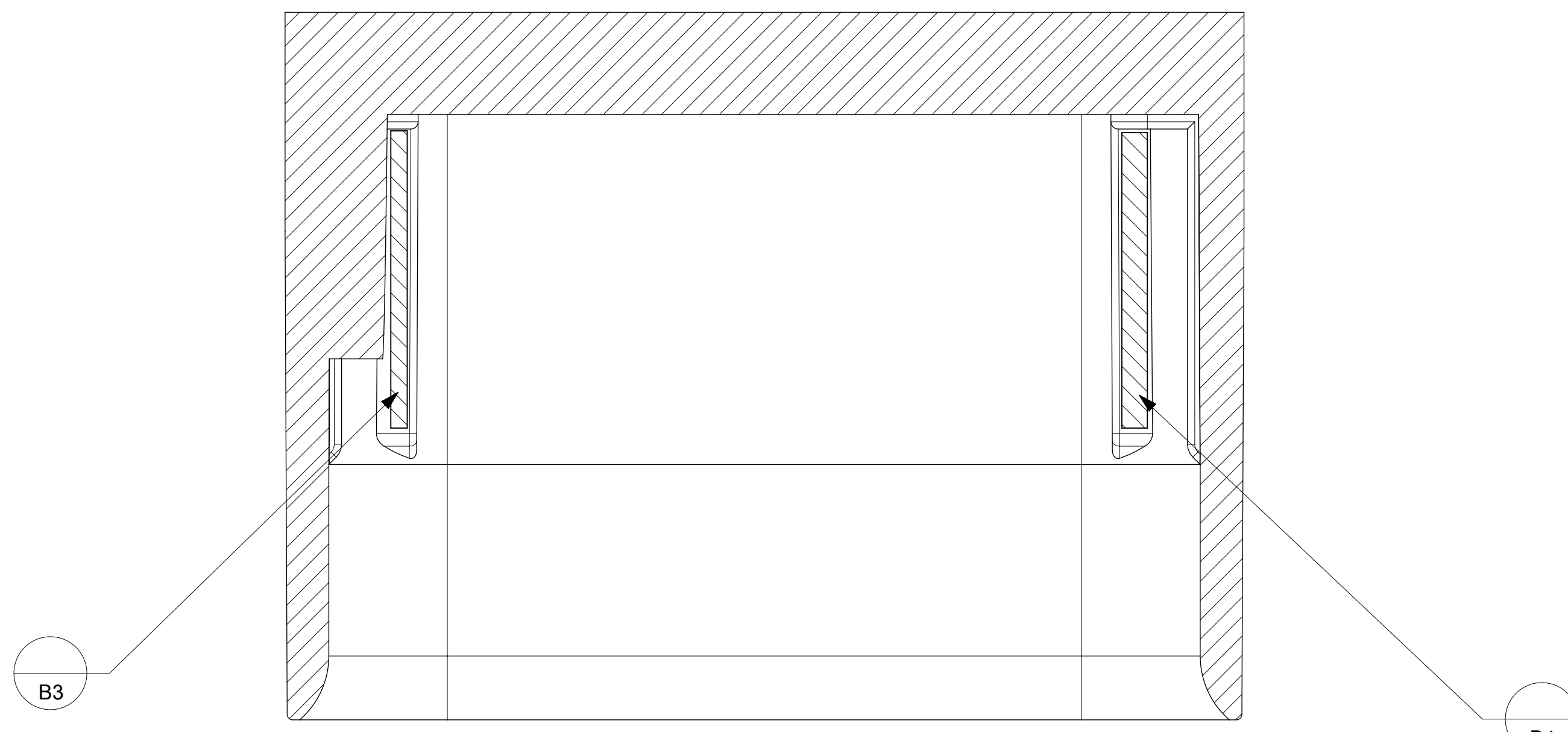

SECTION P-P

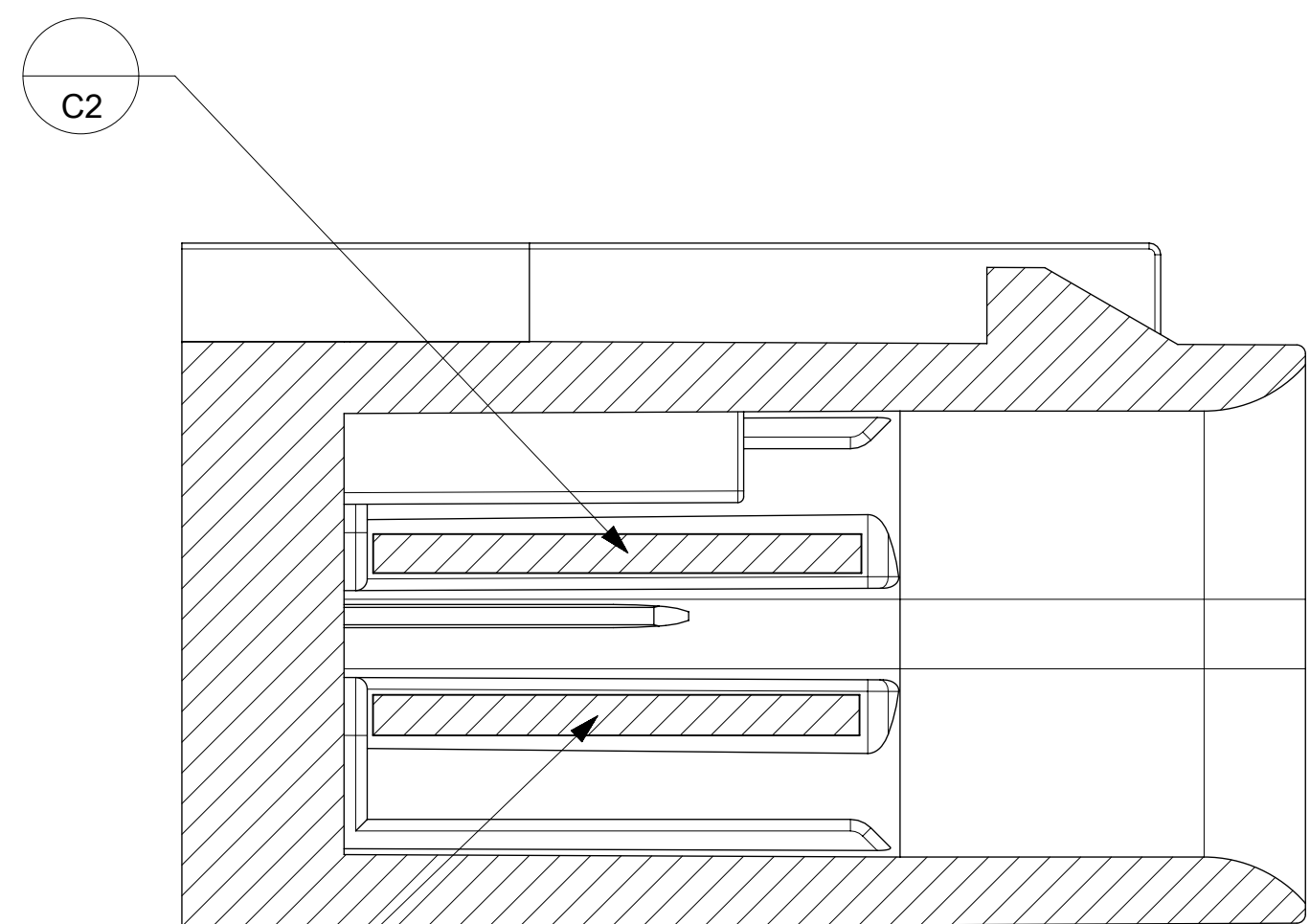

SECTION N-N

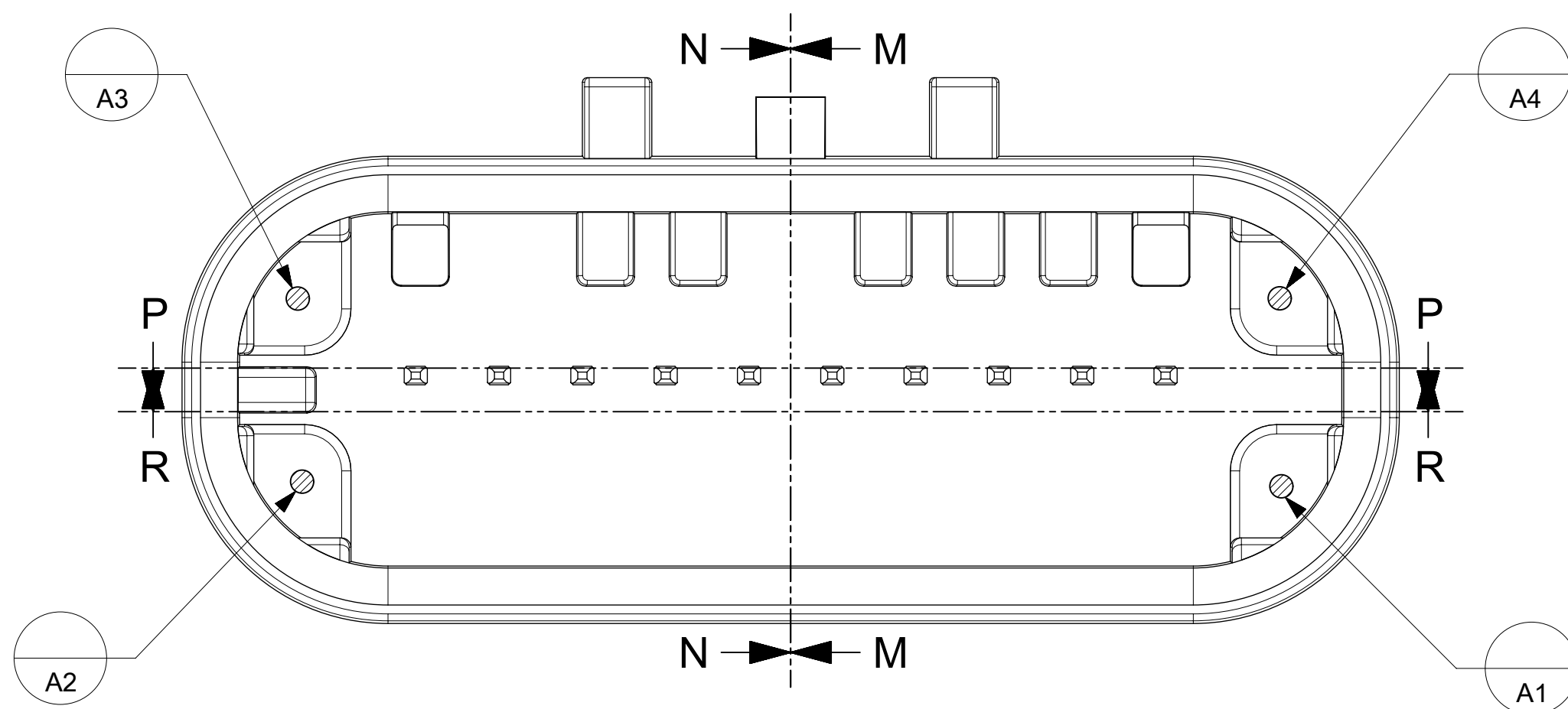

SECTION R-R

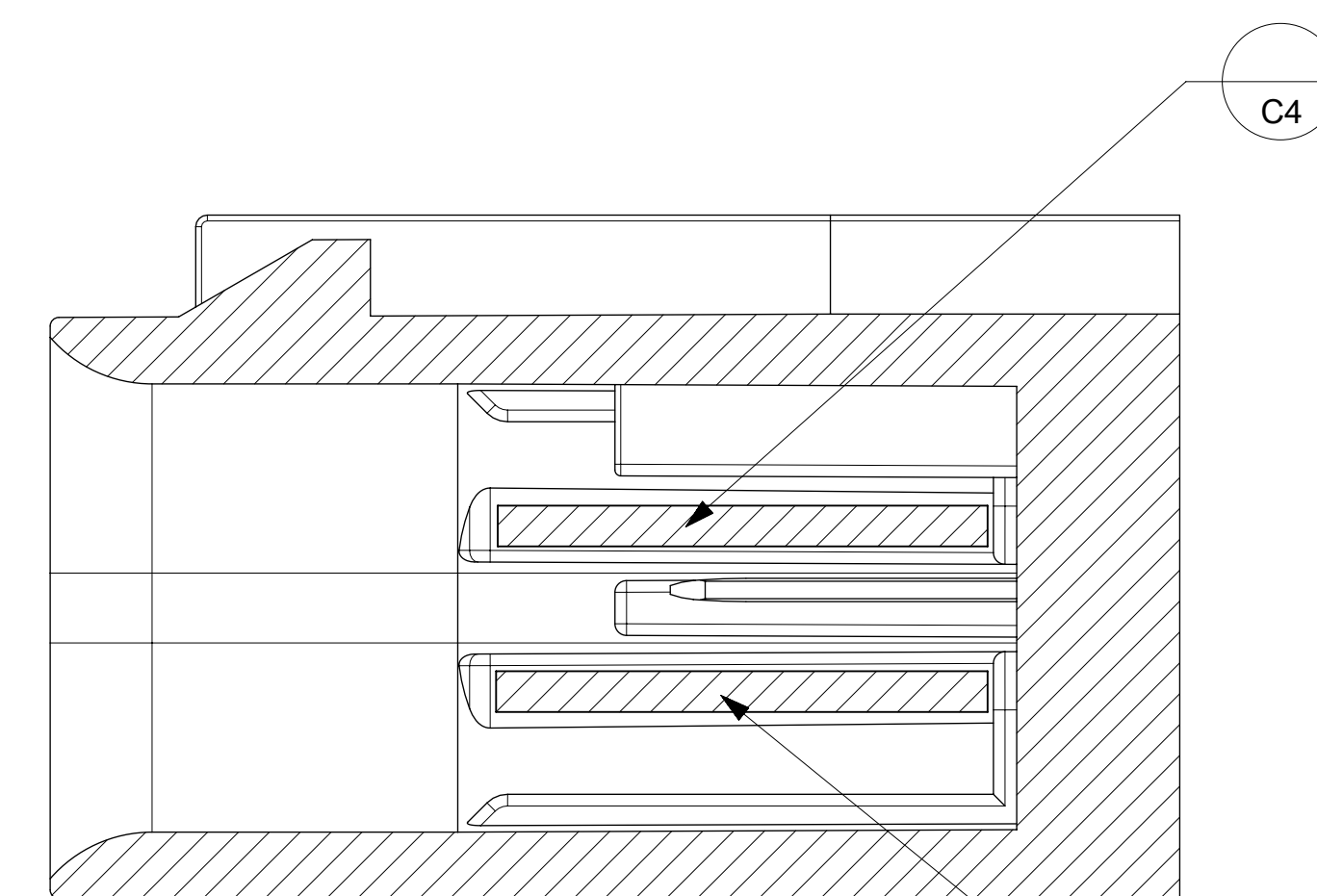

SECTION M-M

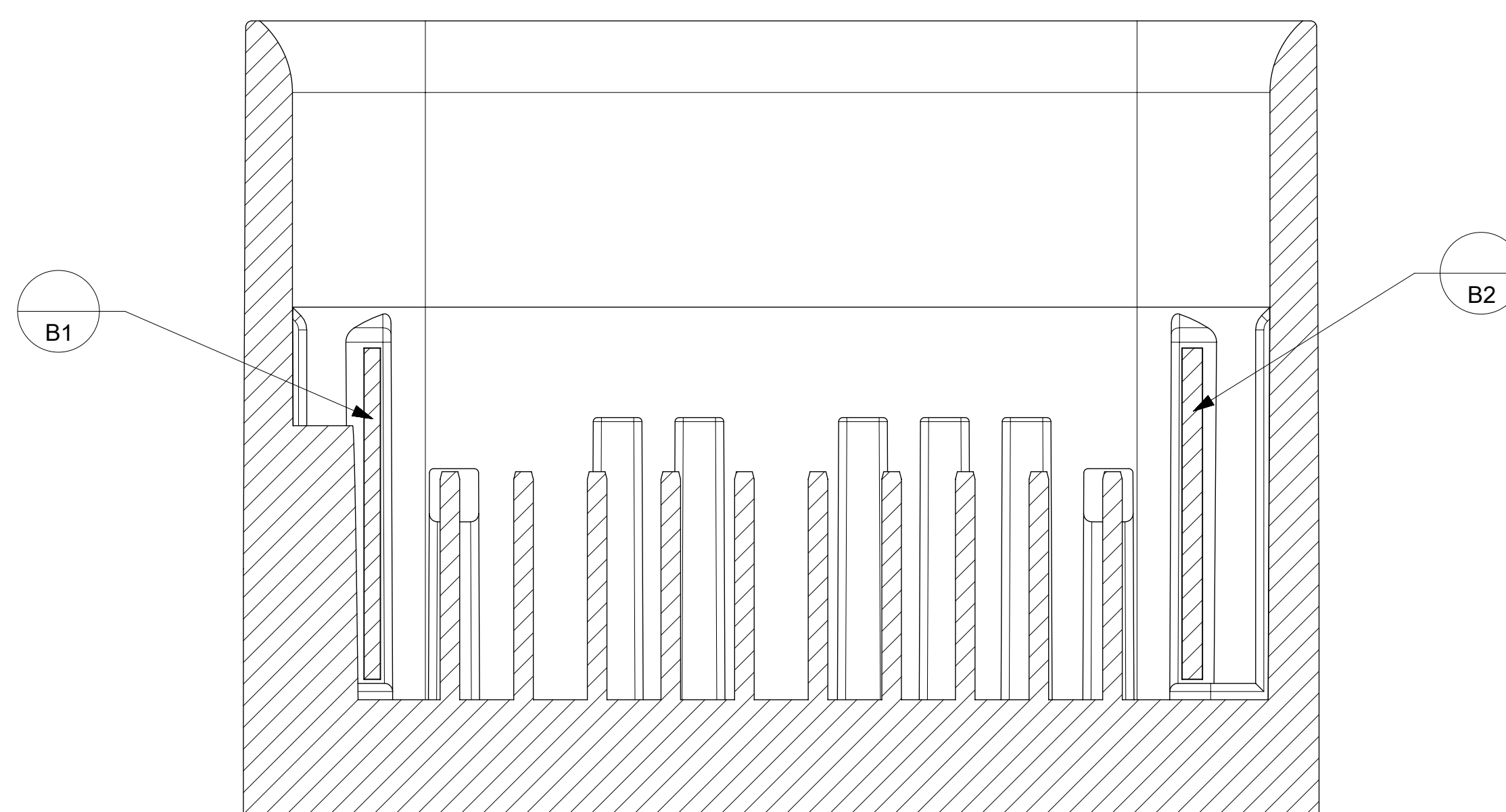

SECTION R-R

<p>QUALITY SYMBOLS</p> <p>▽ = 0</p> <p>▽ = 0</p> <p>▽ = 0</p> <p>▽ = 0</p> <p>▽ = 0</p> <p>▽ = 0</p> <p>▽ = 0</p> <p>▽ = 0</p> <p>▽ = 0</p> <p>▽ = 0</p>	THIS DRAWING CONTAINS INFORMATION THAT IS PROPRIETARY TO MOLEX ELECTRONIC TECHNOLOGIES, LLC AND SHOULD NOT BE USED WITHOUT WRITTEN PERMISSION										
	<p>EC NO: 659036</p> <p>DRWN: ML149</p> <p>CHKD: JCONDON</p> <p>APPR: JCONDON</p>	2021/02/26	2021/03/24	2021/03/24	GENERAL TOLERANCES (UNLESS SPECIFIED)	DIMENSION UNITS	SCALE				
		mm		8:1							
	ANGULAR TOL ± 3.0 °		DRWN BY	DATE		MNS02					
	4 PLACES ±		CHK'D BY		DATE		PRODUCT CUSTOMER DRAWING				
	3 PLACES ±		APPR BY		DATE		SERIES	MATERIAL NUMBER	CUSTOMER		
	2 PLACES ± 0.1		KDEKOSKI		2016/05/04		34968	SEE CHART			
	1 PLACE ± 0.2		DRAWING SIZE		THIRD ANGLE PROJECTION		DOCUMENT NUMBER	DOC TYPE	DOC PART	SHEET NUMBER	
	0 PLACES ±		A1				349681800	PSD	000	4 OF 4	
	DRAFT WHERE APPLICABLE MUST REMAIN WITHIN DIMENSIONS										