

NOTES:

1. ELECTRICAL:

- VOLTAGE RATING PER IEC 60664: 300V
- VOLTAGE RATING PER UL: 300V
- CURRENT: 8A

2. TEMP RATING: -25° TO +60°C

3. PROTECTION: IP67 (WHEN MATED)

4. COUPLING THREAD" 7/8-16

5. AGENCY:

- UL RECOGNIZED, FILE: E152210
- CSA CERTIFICATION FILE: LR6837

6 ALL DIMS ARE FOR REFERENCE UNLES NOTED OTHERWISE

UNLES NOTED OTHERWISE

7. PART NUMBERS WITH "H" HAVE

TWO ID MARKERS ONE ON EACH END

WIRING DIAGRAM

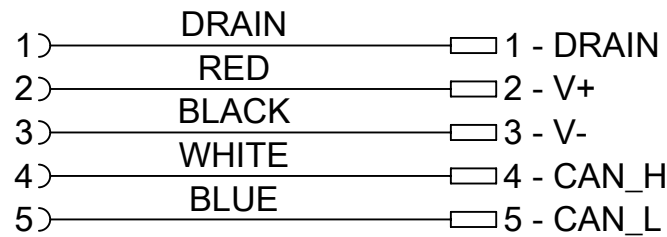

PART No. MATRIX

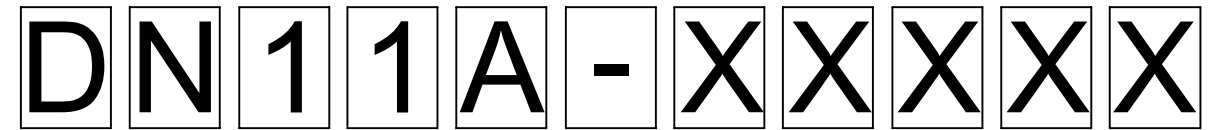

Units:
M = Meter
T = over
100 Meter

Length
Examples:
005 = 0.5 m
010 = 1 m
050 = 5 m
100 = 10 m
150 = 15 m

OPTIONAL:
H = ID CARRIER

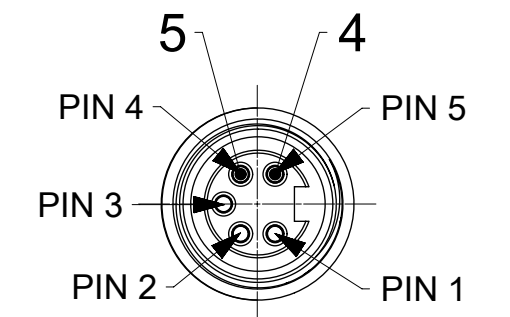

VIEW FROM THE FRONT SIDE

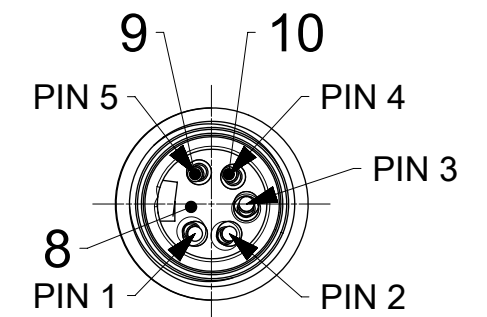
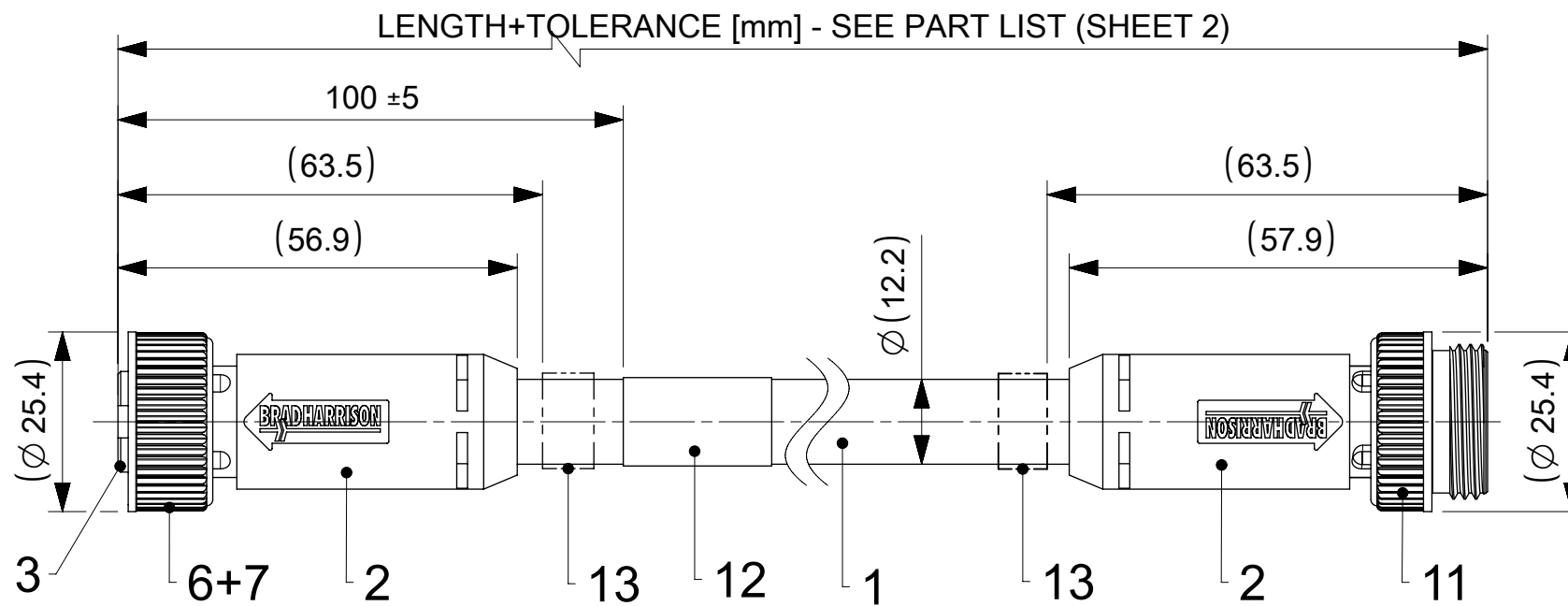

VIEW FROM THE FRONT SIDE

BILL OF MATERIALS

ITEM	QTY	DESCRIPTION	MATERIAL	FINISH/COLOR
13	2	ID CARRIER	PVC	-
12	1	LABEL WRAP	VINYL	YELLOW
11	1	COUPLING NUT A-SIZE EXT.	ZINC	BLACK
10	2	PIN CONTACT 16 AWG	COPPER	GOLD OVER Ni-PLATED
9	3	PIN CONTACT 18 AWG	COPPER	GOLD OVER Ni-PLATED
8	1	HOUSING A-SIZE 5P MALE	ARNITEL	BLACK
7	1	FRICTION RING A-SIZE	NYLON	GRAY
6	1	MC COUPLING NUT A-SIZE	ZINC	BLACK
5	2	MC SOCKET SLEEVE ASSY 16 AWG	COPPER	GOLD OVER Ni-PLATED
4	3	MC SOCKET SLEEVE ASSY 18 AWG	COPPER	GOLD OVER Ni-PLATED
3	1	HOUSING A-SIZE 5P FEMALE	ARNITEL	BLACK
2	-	MOULDING MATERIAL	ARNITEL	BLACK
1	-	TRUNK CABLE 19X30 AWG OD=12	PVC	GRAY
ITEM	QTY	DESCRIPTION	MATERIAL	FINISH/COLOR

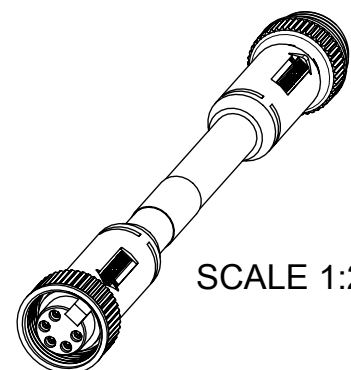

SCALE 1:2

FUNCTIONAL SYMBOLS	THIS DRAWING CONTAINS INFORMATION THAT IS PROPRIETARY TO MOLEX ELECTRONIC TECHNOLOGIES, LLC AND SHOULD NOT BE USED WITHOUT WRITTEN PERMISSION		CURRENT REV DESC: PIN'S ADDED, NOTES UPDATED	
	△/A = 0	mm	SCALE	1:1
DIVISIONAL SYMBOLS	GENERAL TOLERANCES (UNLESS SPECIFIED)		EC NO: 695738	
	△/E = 0	ANGULAR TOL	± 1.0 °	2022/02/14
FUNCTIONAL SYMBOLS	4 PLACES	±	DRWN: RSCHEIBER	2022/02/15
	3 PLACES	±	CHK'D: RSILLER	2022/02/15
	2 PLACES	± 0.05	APPR: RSILLER	2022/02/15
	1 PLACE	± 0.3	INITIAL REVISION:	
0 PLACES	± 0.5	DRWN: MKOWALCZYK01	2018/09/07	
DRAFT WHERE APPLICABLE MUST REMAIN WITHIN DIMENSIONS		THIRD ANGLE PROJECTION	DRAWING	SERIES
			A3-SIZE	130025
DOCUMENT STATUS		P1	RELEASE DATE	2022/02/15 09:19:21
DOCUMENT NUMBER		1300250051		DOC TYPE
SEE SHEET 2		GENERAL MARKET		DOC PART
				REVISION
				B1
				SHEET NUMBER
				1 OF 2

