

END TO END	"L"
DV TO DV	950[24.13]
DV TO EM (-TEX)	835[21.21]
DV TO EM (-SEX)	806[20.48]
EM (-TEX) TO EM (-TEX)	720[18.29]
EM (-TEX) TO EM (-SEX)	691[17.55]
EM (-SEX) TO EM (-SEX)	662[16.81]
DV-N TO DV-N	850[21.59]
DV-N TO EM (-TEX)	785[19.94]
DV-N TO EM (-SEX)	756[19.20]

**Pb** THIS PRODUCT MANUFACTURED WITH LEAD-FREE PROCESSING

EQDP-XXX-XX.XX-XXX-XXX-X-X

DO NOT SCALE FROM THIS PRINT

FIG 1 VERTICAL (EQDP-028-XX.XX-STR-STR-1 SHOWN)

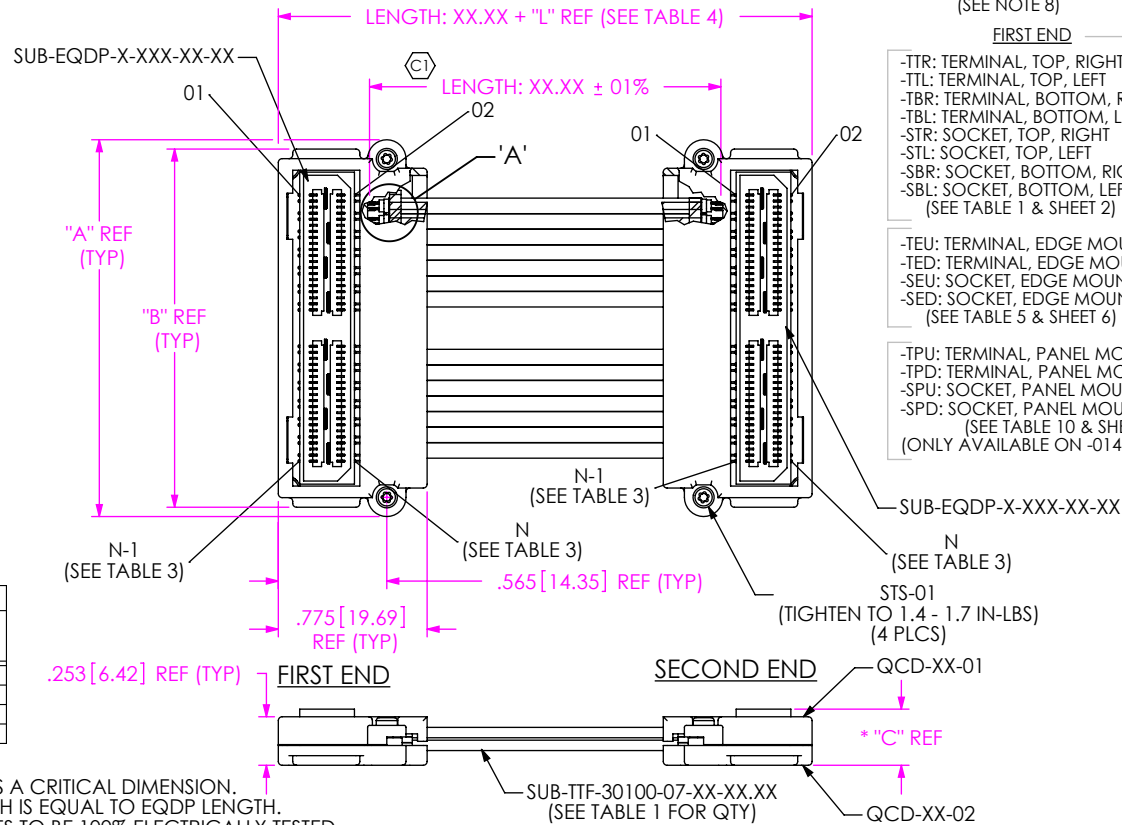

No. OF POSITIONS	N	N-1
-014	28	27
-028	56	55
-042	84	83
-056	112	111

NOTES:

1.  $\odot$  REPRESENTS A CRITICAL DIMENSION.
2. SUB-TTF LENGTH IS EQUAL TO EQDP LENGTH.
3. ALL ASSEMBLIES TO BE 100% ELECTRICALLY TESTED.
4. ALL ASSEMBLIES TO BE 100% HI-POT TESTED AT 300V.
5. TOP SUB-TTF NOT SHOWN IN THIS VIEW FOR CLARITY; HDRL-11 TO BE CENTERED ON LOWER SUB-TTF AS SHOWN; HDRL-11 IS TO CONTAIN PART NUMBER, SHOP NUMBER & DATE CODE.
6. FOR SUB-ASSEMBLY AND FINISHED GOOD PACKAGING REQUIREMENTS, REFERENCE PACKAGING STANDARD CO-HD-WI-3033-M.
7. PARTS TO BE PROCESSED PER SAMTEC ACCEPTABILITY REQUIREMENTS: HDR-PI-01 "CABLE ASSEMBLY WORKMANSHIP STANDARDS".
8. CABLE LENGTHS LONGER THAN 40.00 INCHES ARE NOT SUPPORTED BY S.I. TEST DATA.
9. RT1 OPTION IS NOT AVAILABLE ON EDMOUNT OR PANEL MOUNT END OPTIONS.
10. RT1 OPTION IS NOT AVAILABLE WITH -056 PAIRS.
11. DIFFERENTIAL PAIRS CONSIST OF ADJACENT PINS. FOR EXAMPLE, PIN POSITIONS 1 & 3, 2 & 4, 5 & 7, ETC.
12. ALL POSITIONS ARE TRANSMITTED AS SIGNALS ACROSS TWINAX CENTER CONDUCTORS. CONNECTOR GROUND BLADES ARE TIED TO THE TWINAX SHIELD. FOR MULTIPLE BANK ASSEMBLIES, EACH BANK IS GROUND INDEPENDENT OF THE OTHERS.
13. WIRING OPTION -5 THROUGH -8 USE 30100CU.
14. REFER TO PREP-SPEC DOCUMENT FOR CABLE PREP DIMENSIONS. ASSEMBLY USES STANDARD PCB PREP.

No. OF POSITIONS	"A"	"B"	QCD-XX-01	QCD-XX-02	QTY OF SUB-TTF	SUB-EQDP-X-XXX-XX-XX	WIRING OPTION	
							-1, -2, -3, -4	-5, -6, -7, -8
-014	1.175[29.85]	1.078[27.38]	QCD-01-01	QCD-01-02	2	SUB-EQDP-X-014-XX-XX	SUB-TTF-30100XX-XX-XX-XX-XX	SUB-TTF-30100CU-XX-01-XX-XX
-028	1.963[49.85]	1.866[47.40]	QCD-02-01	QCD-02-02	4	SUB-EQDP-X-028-XX-XX		
-042	2.750[69.85]	2.653[67.39]	QCD-03-01	QCD-03-02	6	SUB-EQDP-X-042-XX-XX		
-056	3.538[89.85]	3.441[87.39]	QCD-04-01	QCD-04-02	8	SUB-EQDP-X-056-XX-XX		

No. OF POSITIONS  
-014, -028, -042, -056  
(PER ROW)

LENGTH  
-XX.XX (INCHES)  
(01.72 [43.7] MIN)  
(SEE NOTE 2)  
(SEE NOTE 8)

FIRST END

- TTR: TERMINAL, TOP, RIGHT
- TTL: TERMINAL, TOP, LEFT
- TBR: TERMINAL, BOTTOM, RIGHT
- TBL: TERMINAL, BOTTOM, LEFT
- STR: SOCKET, TOP, RIGHT
- STL: SOCKET, TOP, LEFT
- SBR: SOCKET, BOTTOM, RIGHT
- SBL: SOCKET, BOTTOM, LEFT (SEE TABLE 1 & SHEET 2)
- TEU: TERMINAL, EDGE MOUNT, UP
- TED: TERMINAL, EDGE MOUNT, DOWN
- SEU: SOCKET, EDGE MOUNT, UP
- SED: SOCKET, EDGE MOUNT, DOWN (SEE TABLE 5 & SHEET 6)
- TPU: TERMINAL, PANEL MOUNT, UP
- TPD: TERMINAL, PANEL MOUNT, DOWN
- SPU: SOCKET, PANEL MOUNT, UP
- SPD: SOCKET, PANEL MOUNT, DOWN (SEE TABLE 10 & SHEET 6) (ONLY AVAILABLE ON -014, -028, AND -042)

END OPTION

- F: SCREW OPTION FIRST END ONLY (NOT AVAILABLE WITH XPX OPTIONS)
- S: SCREW OPTION SECOND END ONLY (NOT AVAILABLE WITH XPX OPTIONS)
- B: SCREW OPTION BOTH ENDS (NOT AVAILABLE WITH XPX OPTIONS)
- L: FIRST END RT1 OPTION (SEE FIG 6, SHT 7) (SEE NOTE 9 & 10)
- R: SECOND END RT1 OPTION (SEE FIG 6, SHT 7) (SEE NOTE 9 & 10)
- D: BOTH ENDS RT1 OPTION (SEE FIG 6, SHT 7) (SEE NOTE 9 & 10)
- 1: FIRST SCREW OPTION, SECOND END RT1 OPTION (SEE FIG 6, SHT 7) (SEE NOTE 9 & 10)
- 2: FIRST END RT1 OPTION, SECOND END SCREW OPTION (SEE FIG 6, SHT 7) (SEE NOTE 9 & 10)
- N: NO CAPS (SEE FIG 3, SHEET 6 FOR EDGE MOUNT END OPTIONS) (SEE FIG. 4, SHEET 6 FOR DOUBLE VERTICAL END OPTIONS) (SEE FIG 5, SHEET 7 FOR NO CAPS OPTIONS) (LEAVE BLANK FOR STANDARD CAPS BOTH ENDS)

WIRING OPTION

- \*\* -1: PIN 1 TO PIN 1
- \*\* -2: PIN 1 TO PIN 2
- \*\* -3: PIN 1 TO PIN N-1
- \*\* -4: PIN 1 TO PIN N
- 5: PIN 1 TO PIN 1
- 6: PIN 1 TO PIN 2
- 7: PIN 1 TO PIN N-1
- 8: PIN 1 TO PIN N (SEE NOTE 13)

- TEU: TERMINAL, EDGE MOUNT, UP
- TED: TERMINAL, EDGE MOUNT, DOWN
- SEU: SOCKET, EDGE MOUNT, UP
- SED: SOCKET, EDGE MOUNT, DOWN (SEE TABLE 5 & SHEET 6)

- TPU: TERMINAL, PANEL MOUNT, UP
- TPD: TERMINAL, PANEL MOUNT, DOWN
- SPU: SOCKET, PANEL MOUNT, UP
- SPD: SOCKET, PANEL MOUNT, DOWN (SEE TABLE 10 & SHEET 6) (ONLY AVAILABLE ON -014, -028, AND -042)

END	"C"
-TXX	.332[8.43]
-SXX	.296[7.52]

\* -DV END OPTIONS ONLY  
\*\* : AVAILABLE TO EXISTING CUSTOMERS ONLY

UNLESS OTHERWISE SPECIFIED, DIMENSIONS ARE IN INCHES.

TOLERANCES ARE:

DECIMALS	ANGLES
.XX: ±.01 [3]	2°
.XXX: ±.005 [13]	
.XXXX: ±.0020 [051]	

PROPRIETARY NOTE  
THIS DOCUMENT CONTAINS CONFIDENTIAL AND PROPRIETARY INFORMATION AND ALL DESIGN, MANUFACTURING, REPRODUCTION, USE, PATENT RIGHTS AND SALES RIGHTS ARE EXPRESSLY RESERVED BY SAMTEC, INC. THIS DOCUMENT SHALL NOT BE DISCLOSED, IN WHOLE OR PART, TO ANY UNAUTHORIZED PERSON OR ENTITY NOR REPRODUCED, TRANSFERRED OR INCORPORATED IN ANY OTHER PROJECT IN ANY MANNER WITHOUT THE EXPRESS WRITTEN CONSENT OF SAMTEC, INC.

MATERIAL: DO NOT SCALE DRAWING SHEET SCALE: 1:1  
PLATING: -H GOLD: 30 μ CONTACT

DESCRIPTION:  
0.8mm HIGH-SPEED TWIN-AX CABLE ASSEMBLY

DWG. NO.  
EQDP-XXX-XX.XX-XXX-XXX-X-X

BY: BRATCHER 11/13/03 SHEET 1 OF 9

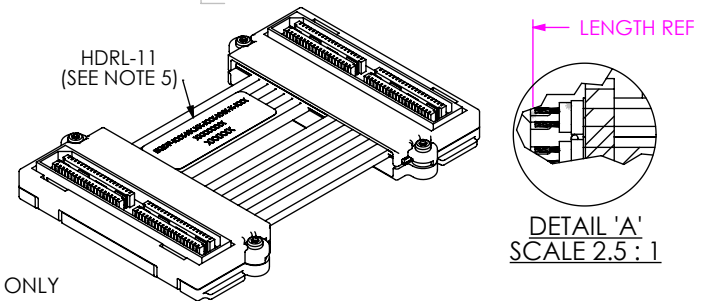

DETAIL 'A' SCALE 2.5 : 1

-TTR

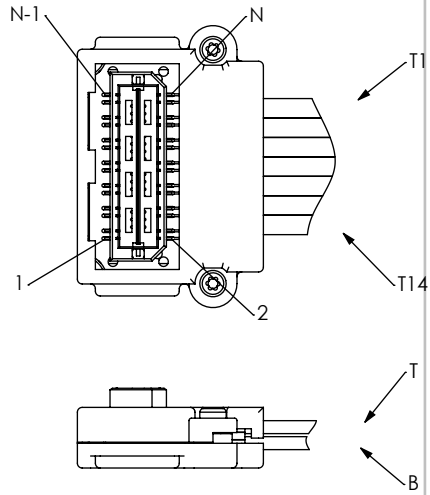

WIRING OPTION	FIRST END PIN #	SECOND END PIN #	WIRE NUMBER	WIRING OPTION	FIRST END PIN #	SECOND END PIN #	WIRE NUMBER
1	1	1	B14	5	1	1	B14
2	1	2	B14	6	1	2	B14
3	1	N-1	B14	7	1	N-1	B14
4	1	N	B14	8	1	N	B14

-TTL

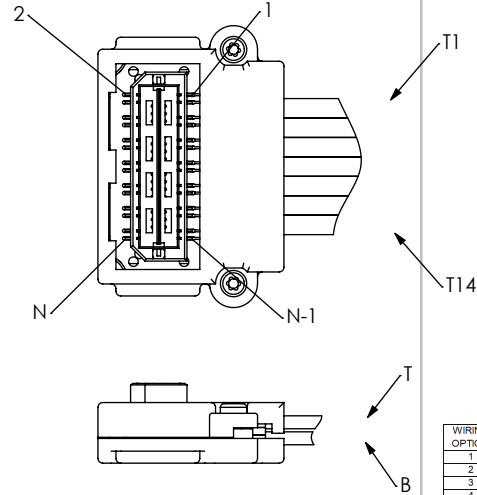

WIRING OPTION	FIRST END PIN #	SECOND END PIN #	WIRE NUMBER	WIRING OPTION	FIRST END PIN #	SECOND END PIN #	WIRE NUMBER
1	1	1	T1	5	1	1	T1
2	1	2	T1	6	1	2	T1
3	1	N-1	T1	7	1	N-1	T1
4	1	N	T1	8	1	N	T1

-TBR

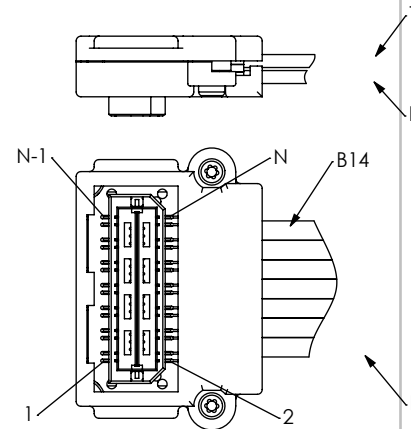

WIRING OPTION	FIRST END PIN #	SECOND END PIN #	WIRE NUMBER	WIRING OPTION	FIRST END PIN #	SECOND END PIN #	WIRE NUMBER
1	1	1	T1	5	1	1	T1
2	1	2	T1	6	1	2	T1
3	1	N-1	T1	7	1	N-1	T1
4	1	N	T1	8	1	N	T1

-TBL

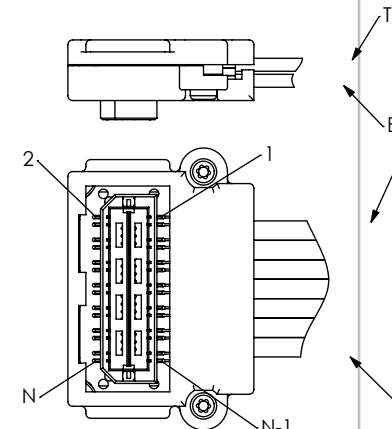

WIRING OPTION	FIRST END PIN #	SECOND END PIN #	WIRE NUMBER	WIRING OPTION	FIRST END PIN #	SECOND END PIN #	WIRE NUMBER
1	1	1	B14	5	1	1	B14
2	1	2	B14	6	1	2	B14
3	1	N-1	B14	7	1	N-1	B14
4	1	N	B14	8	1	N	B14

-SBR

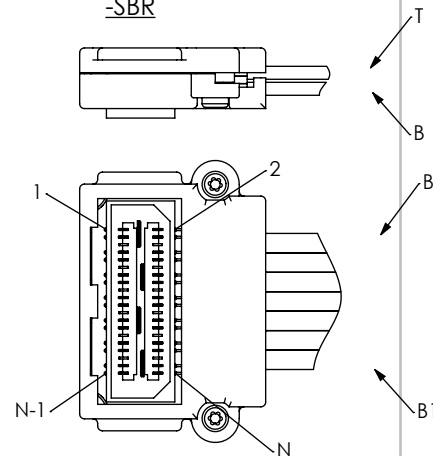

WIRING OPTION	FIRST END PIN #	SECOND END PIN #	WIRE NUMBER	WIRING OPTION	FIRST END PIN #	SECOND END PIN #	WIRE NUMBER
1	1	1	T14	5	1	1	T14
2	1	2	T14	6	1	2	T14
3	1	N-1	T14	7	1	N-1	T14
4	1	N	T14	8	1	N	T14

-SBL

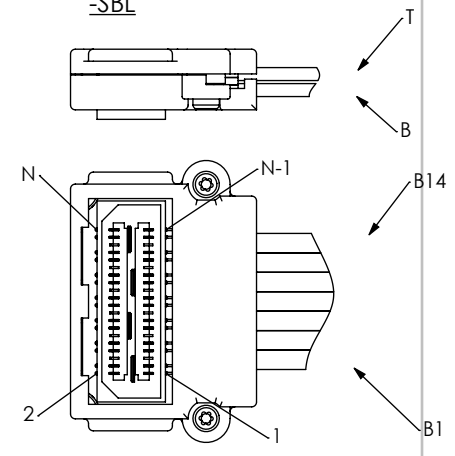

WIRING OPTION	FIRST END PIN #	SECOND END PIN #	WIRE NUMBER	WIRING OPTION	FIRST END PIN #	SECOND END PIN #	WIRE NUMBER
1	1	1	B1	5	1	1	B1
2	1	2	B1	6	1	2	B1
3	1	N-1	B1	7	1	N-1	B1
4	1	N	B1	8	1	N	B1

-STR

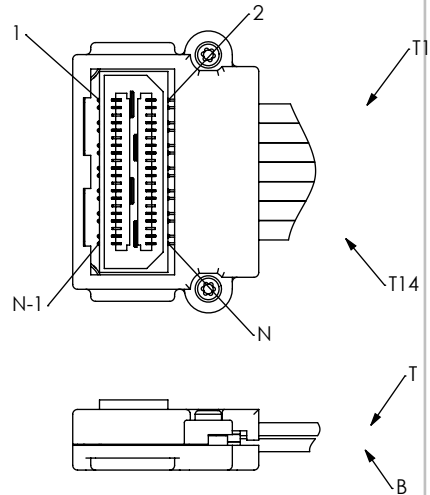

WIRING OPTION	FIRST END PIN #	SECOND END PIN #	WIRE NUMBER	WIRING OPTION	FIRST END PIN #	SECOND END PIN #	WIRE NUMBER
1	1	1	B1	5	1	1	B1
2	1	2	B1	6	1	2	B1
3	1	N-1	B1	7	1	N-1	B1
4	1	N	B1	8	1	N	B1

-STL

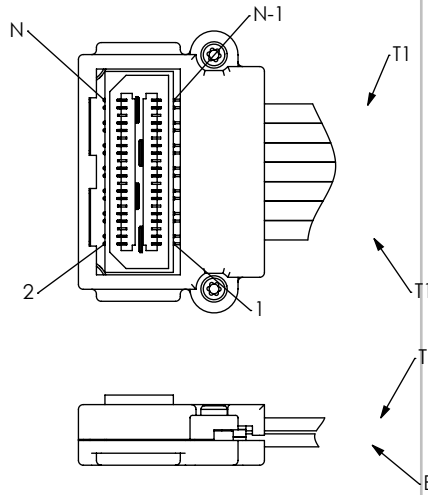

WIRING OPTION	FIRST END PIN #	SECOND END PIN #	WIRE NUMBER	WIRING OPTION	FIRST END PIN #	SECOND END PIN #	WIRE NUMBER
1	1	1	T14	5	1	1	T14
2	1	2	T14	6	1	2	T14
3	1	N-1	T14	7	1	N-1	T14
4	1	N	T14	8	1	N	T14

PROPRIETARY NOTE

THIS DOCUMENT CONTAINS CONFIDENTIAL AND PROPRIETARY INFORMATION AND ALL DESIGN, MANUFACTURING, REPRODUCTION, USE, PATENT RIGHTS AND SALES RIGHTS ARE EXPRESSLY RESERVED BY SAMTEC, INC. THIS DOCUMENT SHALL NOT BE DISCLOSED, IN WHOLE OR PART, TO ANY UNAUTHORIZED PERSON OR ENTITY NOR REPRODUCED, TRANSFERRED OR INCORPORATED IN ANY OTHER PROJECT IN ANY MANNER WITHOUT THE EXPRESS WRITTEN CONSENT OF SAMTEC, INC.

DO NOT SCALE DRAWING

SHEET SCALE: 1:25:1



520 PARK EAST BLVD. NEW ALBANY, IN 47150  
PHONE: 812-944-6733 FAX: 812-948-5047  
e-Mail: info@SAMTEC.com code: 55322

DESCRIPTION:  
0.8mm HIGH-SPEED TWIN-AX CABLE ASSEMBLY

DWG. NO.  
EQDP-XXX-XX.XX-XXX-XXX-X-X

BY: BRATCHER 11/13/03 SHEET 2 OF 9

REVISION X

FIRST END - EDGE MOUNT (SEE TABLE 9, SHEET 8 & 9)

-TEU

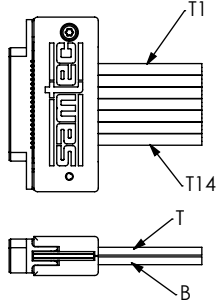
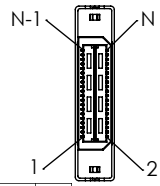

WIRING OPTION	FIRST END PIN #	SECOND END PIN #	WIRE #
1	1	1	T1
2	1	2	T1
3	1	N-1	T1
4	1	N	T1
5	1	1	T1
6	1	2	T1
7	1	N-1	T1
8	1	N	T1

-TED

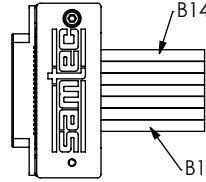
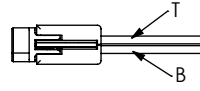

WIRING OPTION	FIRST END PIN #	SECOND END PIN #	WIRE #
1	1	1	B14
2	1	2	B14
3	1	N-1	B14
4	1	N	B14
5	1	1	B14
6	1	2	B14
7	1	N-1	B14
8	1	N	B14

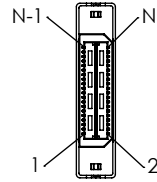

-SEU

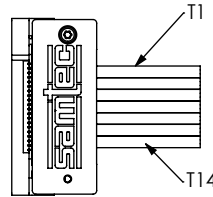
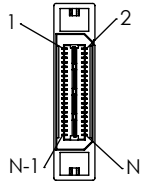

WIRING OPTION	FIRST END PIN #	SECOND END PIN #	WIRE #
1	1	1	T14
2	1	2	T14
3	1	N-1	T14
4	1	N	T14
5	1	1	T14
6	1	2	T14
7	1	N-1	T14
8	1	N	T14

-SED

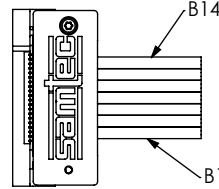
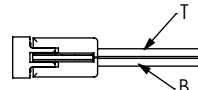

WIRING OPTION	FIRST END PIN #	SECOND END PIN #	WIRE #
1	1	1	B1
2	1	2	B1
3	1	N-1	B1
4	1	N	B1
5	1	1	B1
6	1	2	B1
7	1	N-1	B1
8	1	N	B1

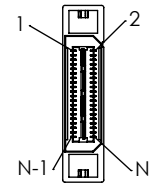

-SPU

FIRST END - PANEL MOUNT (SEE TABLE 9, SHEET 8 & 9)

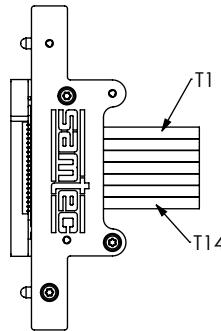
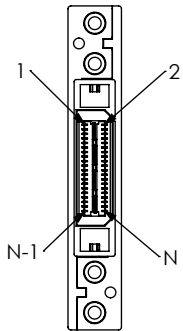

WIRING OPTION	FIRST END PIN #	SECOND END PIN #	WIRE #
1	1	1	T14
2	1	2	T14
3	1	N-1	T14
4	1	N	T14
5	1	1	T14
6	1	2	T14
7	1	N-1	T14
8	1	N	T14

-SPD

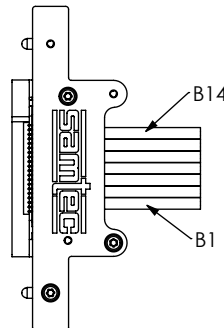
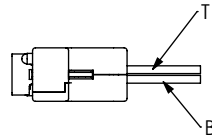

WIRING OPTION	FIRST END PIN #	SECOND END PIN #	WIRE #
1	1	1	B1
2	1	2	B1
3	1	N-1	B1
4	1	N	B1
5	1	1	B1
6	1	2	B1
7	1	N-1	B1
8	1	N	B1

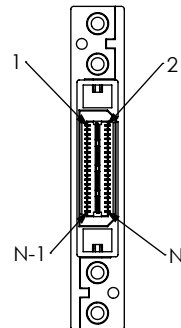

-TPU

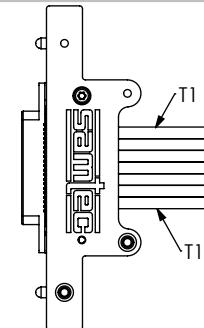
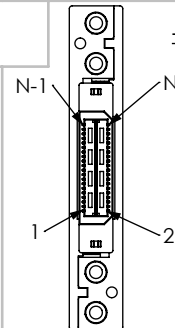

WIRING OPTION	FIRST END PIN #	SECOND END PIN #	WIRE #
1	1	1	B14
2	1	2	B14
3	1	N-1	B14
4	1	N	B14
5	1	1	B14
6	1	2	B14
7	1	N-1	B14
8	1	N	B14

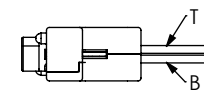

**PROPRIETARY NOTE**  
 THIS DOCUMENT CONTAINS CONFIDENTIAL AND PROPRIETARY INFORMATION AND ALL DESIGN, MANUFACTURING, REPRODUCTION, USE, PATENT RIGHTS AND SALES RIGHTS ARE EXPRESSLY RESERVED BY SAMTEC, INC. THIS DOCUMENT SHALL NOT BE DISCLOSED, IN WHOLE OR PART, TO ANY UNAUTHORIZED PERSON OR ENTITY NOR REPRODUCED, TRANSFERRED OR INCORPORATED IN ANY OTHER PROJECT IN ANY MANNER WITHOUT THE EXPRESS WRITTEN CONSENT OF SAMTEC, INC.

DO NOT SCALE DRAWING

SHEET SCALE: 1:1

WIRING OPTION	FIRST END PIN #	SECOND END PIN #	WIRE #
1	1	1	T1
2	1	2	T1
3	1	N-1	T1
4	1	N	T1
5	1	1	T1
6	1	2	T1
7	1	N-1	T1
8	1	N	T1

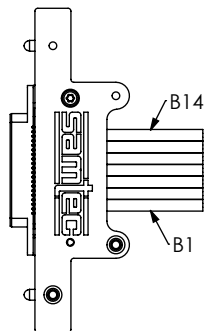
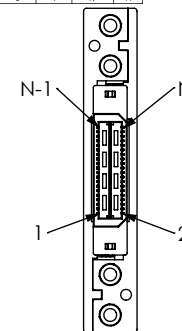
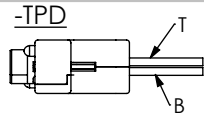

520 PARK EAST BLVD, NEW ALBANY, IN 47150  
 PHONE: 812-944-6733 FAX: 812-948-5047  
 e-Mail: info@SAMTEC.com code: 55322

DESCRIPTION:  
 0.8mm HIGH-SPEED TWIN-AX CABLE ASSEMBLY  
 DWG. NO.  
 EQDP-XXX-XX.XX-XXX-XXX-X-X  
 BY: BRATCHER 11/13/03 SHEET 3 OF 9

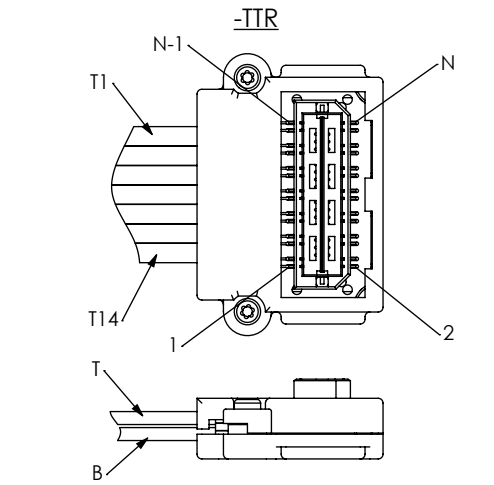

WIRING OPTION	FIRST END PIN #	SECOND END PIN #	WIRING OPTION	FIRST END PIN #	SECOND END PIN #
1	1	1	5	1	1
2	1	2	6	1	2
3	1	N-1	7	1	N-1
4	1	N	8	1	N

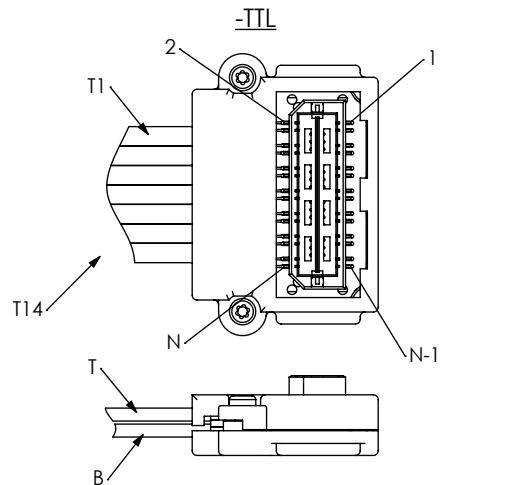

WIRING OPTION	FIRST END PIN #	SECOND END PIN #	WIRING OPTION	FIRST END PIN #	SECOND END PIN #
1	1	1	5	1	1
2	1	2	6	1	2
3	1	N-1	7	1	N-1
4	1	N	8	1	N

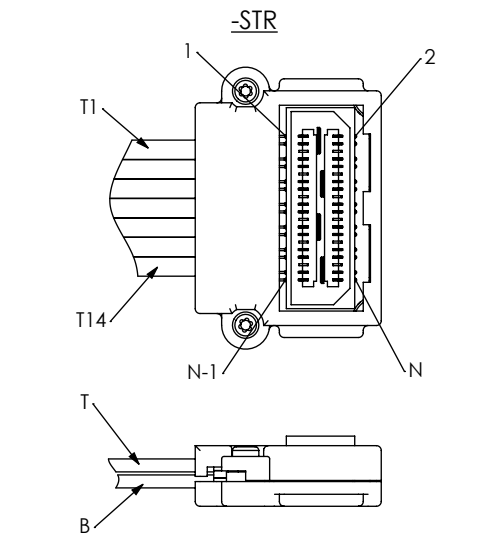

WIRING OPTION	FIRST END PIN #	SECOND END PIN #	WIRING OPTION	FIRST END PIN #	SECOND END PIN #
1	1	1	5	1	1
2	1	2	6	1	2
3	1	N-1	7	1	N-1
4	1	N	8	1	N

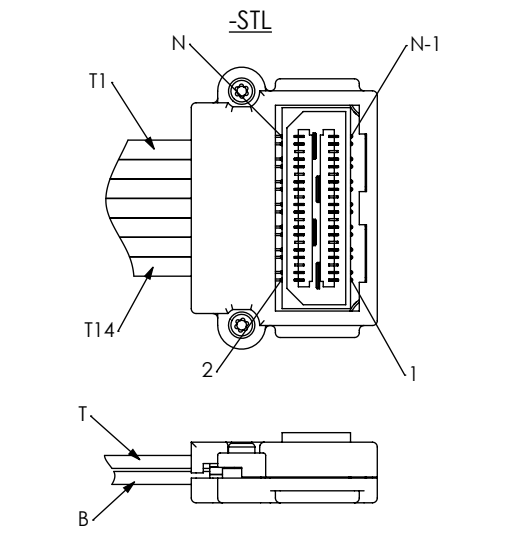

WIRING OPTION	FIRST END PIN #	SECOND END PIN #	WIRING OPTION	FIRST END PIN #	SECOND END PIN #
1	1	1	5	1	1
2	1	2	6	1	2
3	1	N-1	7	1	N-1
4	1	N	8	1	N

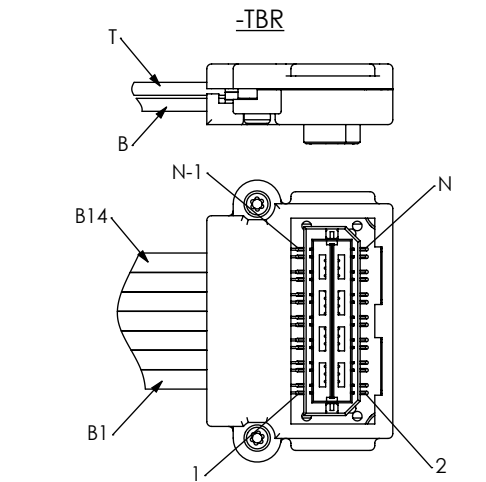

WIRING OPTION	FIRST END PIN #	SECOND END PIN #	WIRING OPTION	FIRST END PIN #	SECOND END PIN #
1	1	1	5	1	1
2	1	2	6	1	2
3	1	N-1	7	1	N-1
4	1	N	8	1	N

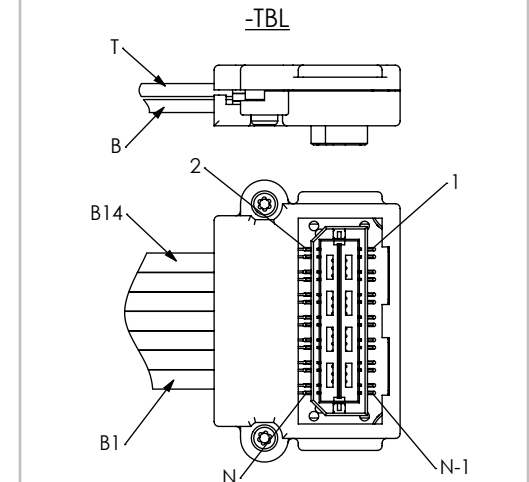

WIRING OPTION	FIRST END PIN #	SECOND END PIN #	WIRING OPTION	FIRST END PIN #	SECOND END PIN #
1	1	1	5	1	1
2	1	2	6	1	2
3	1	N-1	7	1	N-1
4	1	N	8	1	N

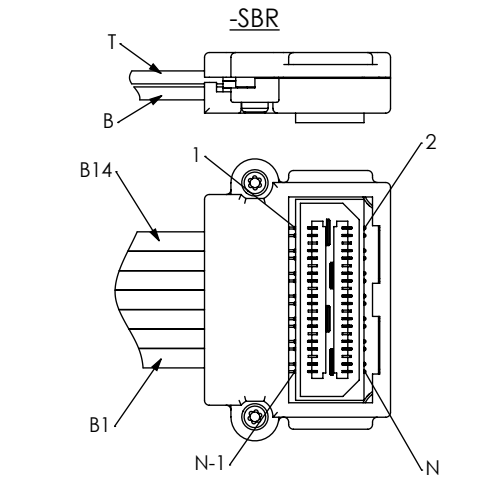

WIRING OPTION	FIRST END PIN #	SECOND END PIN #	WIRING OPTION	FIRST END PIN #	SECOND END PIN #
1	1	1	5	1	1
2	1	2	6	1	2
3	1	N-1	7	1	N-1
4	1	N	8	1	N

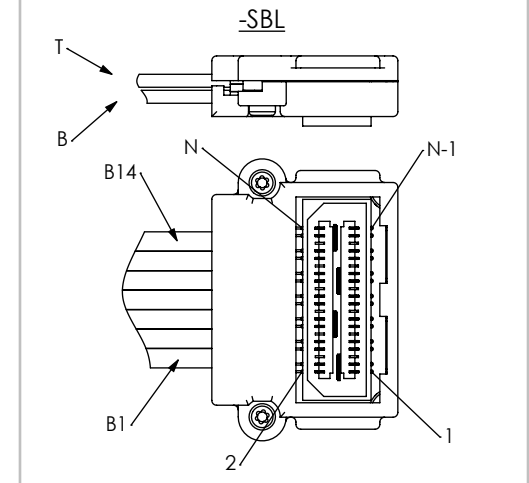

WIRING OPTION	FIRST END PIN #	SECOND END PIN #	WIRING OPTION	FIRST END PIN #	SECOND END PIN #
1	1	1	5	1	1
2	1	2	6	1	2
3	1	N-1	7	1	N-1
4	1	N	8	1	N

**PROPRIETARY NOTE**  
 THIS DOCUMENT CONTAINS CONFIDENTIAL AND PROPRIETARY INFORMATION AND ALL DESIGN, MANUFACTURING, REPRODUCTION, USE, PATENT RIGHTS AND SALES RIGHTS ARE EXPRESSLY RESERVED BY SAMTEC, INC. THIS DOCUMENT SHALL NOT BE DISCLOSED, IN WHOLE OR PART, TO ANY UNAUTHORIZED PERSON OR ENTITY NOR REPRODUCED, TRANSFERRED OR INCORPORATED IN ANY OTHER PROJECT IN ANY MANNER WITHOUT THE EXPRESS WRITTEN CONSENT OF SAMTEC, INC.

DO NOT SCALE DRAWING  
 SHEET SCALE: 1:25:1



520 PARK EAST BLVD. NEW ALBANY, IN 47150  
 PHONE: 812-944-6733 FAX: 812-948-5047  
 e-Mail: info@SAMTEC.com code: 55322

DESCRIPTION:  
 0.8mm HIGH-SPEED TWIN-AX CABLE ASSEMBLY  
 DWG. NO. EQDP-XXX-XX.XX-XXX-XXX-X-X  
 BY: BRATCHER 11/13/03 SHEET 4 OF 9

REVISION X

SECOND END - EDGE MOUNT (SEE TABLE 9, SHEET 8 & 9)

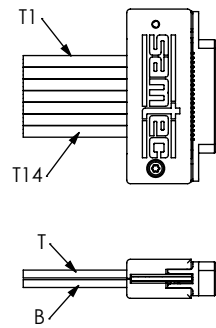

-TEU

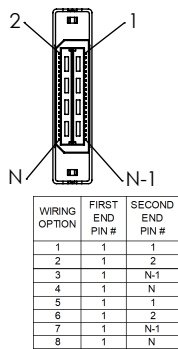

WIRING OPTION	FIRST END PIN #	SECOND END PIN #
1	1	1
2	1	2
3	1	N-1
4	1	N
5	1	1
6	1	2
7	1	N-1
8	1	N

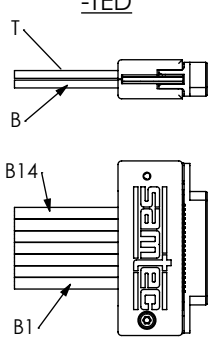

-TED

WIRING OPTION	FIRST END PIN #	SECOND END PIN #
1	1	1
2	1	2
3	1	N-1
4	1	N
5	1	1
6	1	2
7	1	N-1
8	1	N

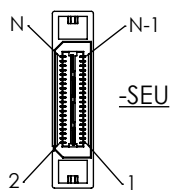
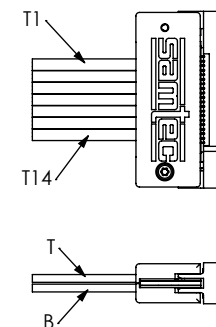
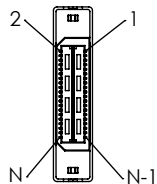

-SEU

WIRING OPTION	FIRST END PIN #	SECOND END PIN #
1	1	1
2	1	2
3	1	N-1
4	1	N
5	1	1
6	1	2
7	1	N-1
8	1	N

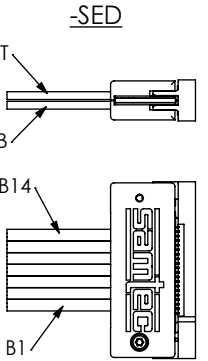

-SED

WIRING OPTION	FIRST END PIN #	SECOND END PIN #
1	1	1
2	1	2
3	1	N-1
4	1	N
5	1	1
6	1	2
7	1	N-1
8	1	N

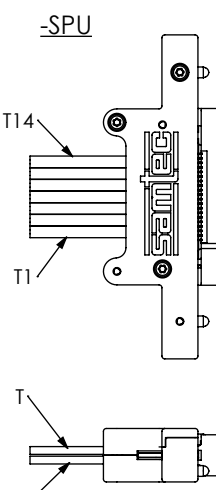
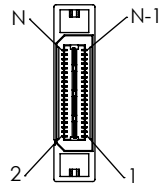

-SPU

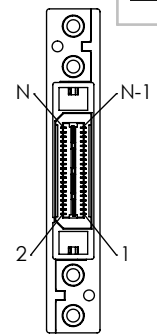

WIRING OPTION	FIRST END PIN #	SECOND END PIN #
1	1	1
2	1	2
3	1	N-1
4	1	N
5	1	1
6	1	2
7	1	N-1
8	1	N

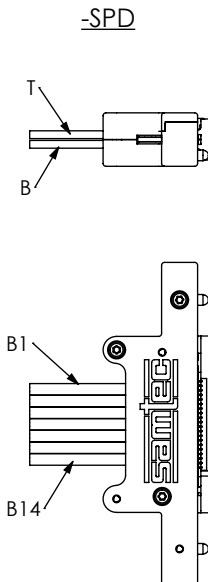

-SPD

WIRING OPTION	FIRST END PIN #	SECOND END PIN #
1	1	1
2	1	2
3	1	N-1
4	1	N
5	1	1
6	1	2
7	1	N-1
8	1	N

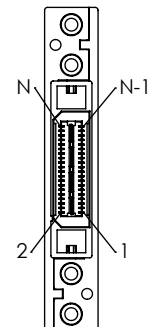

SECOND END - PANEL MOUNT (SEE TABLE 9, SHEET 8 & 9)

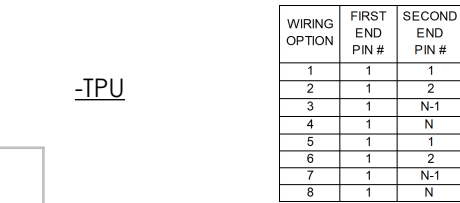

-TPU

WIRING OPTION	FIRST END PIN #	SECOND END PIN #
1	1	1
2	1	2
3	1	N-1
4	1	N
5	1	1
6	1	2
7	1	N-1
8	1	N

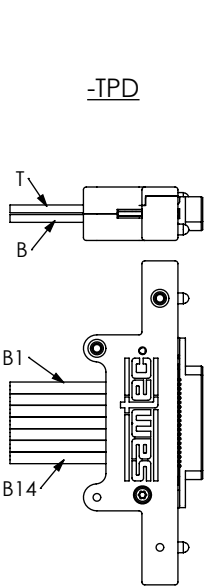

-TPD

WIRING OPTION	FIRST END PIN #	SECOND END PIN #
1	1	1
2	1	2
3	1	N-1
4	1	N
5	1	1
6	1	2
7	1	N-1
8	1	N

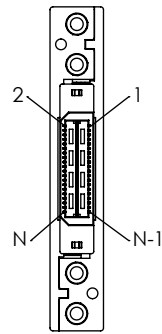

**PROPRIETARY NOTE**  
 THIS DOCUMENT CONTAINS CONFIDENTIAL AND PROPRIETARY INFORMATION AND ALL DESIGN, MANUFACTURING, REPRODUCTION, USE, PATENT RIGHTS AND SALES RIGHTS ARE EXPRESSLY RESERVED BY SAMTEC, INC. THIS DOCUMENT SHALL NOT BE DISCLOSED, IN WHOLE OR PART, TO ANY UNAUTHORIZED PERSON OR ENTITY NOR REPRODUCED, TRANSFERRED OR INCORPORATED IN ANY OTHER PROJECT IN ANY MANNER WITHOUT THE EXPRESS WRITTEN CONSENT OF SAMTEC, INC.

DO NOT SCALE DRAWING

SHEET SCALE: 1:1



520 PARK EAST BLVD, NEW ALBANY, IN 47150  
 PHONE: 812-944-6733 FAX: 812-948-5047  
 e-Mail: info@SAMTEC.com code: 55322

DESCRIPTION:  
 0.8mm HIGH-SPEED TWIN-AX CABLE ASSEMBLY

DWG. NO.  
 EQDP-XXX-XX.XX-XXX-XXX-X-X

BY: BRATCHER 11/13/03 SHEET 5 OF 9

**FIG 3**  
EDGE MOUNT (WITH CAPTIVE PANEL SCREWS)  
(EQDP-014-XX.XX-SEU-XXX-1-F SHOWN)  
(SAME AS FIG 2, UNLESS OTHERWISE STATED)

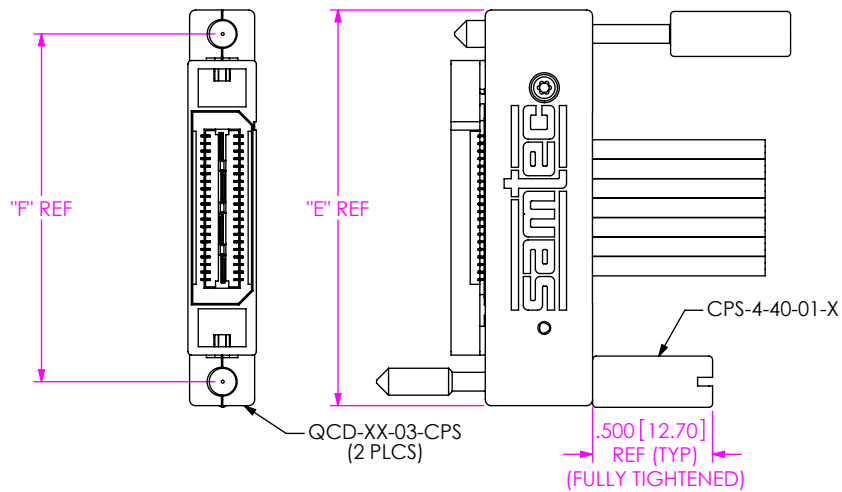

**FIG 4**  
DOUBLE VERTICAL (WITH SCREW DOWN OPTION)  
(EQDP-014-XX.XX-TTR-XXX-1-F SHOWN)  
(SAME AS FIG 1, UNLESS OTHERWISE STATED)

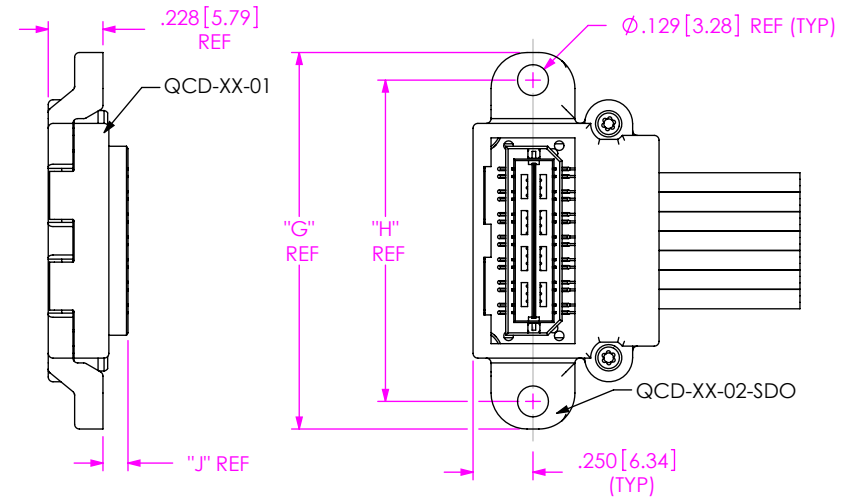

**TABLE 6**

No. OF POSITIONS	"E"	"F"	QCD-XX-03-CPS	WIRING OPTION	
				-1, -2, -3, -4	-5, -6, -7, -8
-014	1.649[41.87]	1.449[36.80]	QCD-01-03-CPS		
-028	2.437[61.90]	2.237[56.80]	QCD-02-03-CPS	SUB-TTF-30100XX-XX-XX-XX	SUB-TTF-30100CU-XX-01-XX-XX
-042	3.224[81.87]	3.024[76.80]	QCD-03-03-CPS		
-056	4.012[101.90]	3.812[96.80]	QCD-04-03-CPS		

**TABLE 7**

No. OF POSITIONS	"G"	"H"	QCD-XX-02-SDO	WIRING OPTION	
				-1, -2, -3, -4	-5, -6, -7, -8
-014	1.569[39.85]	1.339[34.00]	QCD-01-02-SDO		
-028	2.356[59.84]	2.126[54.00]	QCD-02-02-SDO	SUB-TTF-30100XX-XX-XX-XX	SUB-TTF-30100CU-XX-01-XX-XX
-042	3.144[79.86]	2.913[74.00]	QCD-03-02-SDO		
-056	3.931[99.85]	3.701[94.00]	QCD-04-02-SDO		

**TABLE 8**

END	"J"
-TXX	.104[2.65]
-SXX	.068[1.73]

**FIG 2**  
EDGE MOUNT (NO CAPTIVE PANEL SCREWS)  
(EQDP-014-XX.XX-TEU-STR-X SHOWN)  
(SAME AS FIG 1, UNLESS OTHERWISE STATED)

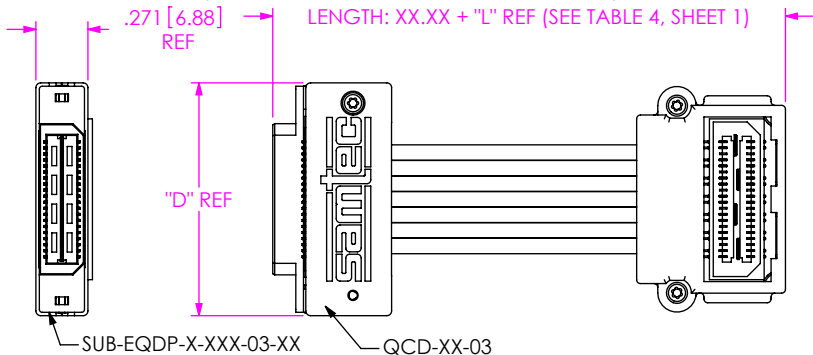

**TABLE 5**

No. OF POSITIONS	"D"	QCD-XXX-03	SUB-EQDP-X-XXX-XX-XX	WIRING OPTION	
				-1, -2, -3, -4	-5, -6, -7, -8
-014	1.213[30.80]	QCD-01-03	SUB-EQDP-X-014-03-XX		
-028	2.000[50.80]	QCD-02-03	SUB-EQDP-X-028-03-XX	SUB-TTF-30100XX-XX-XX-XX	SUB-TTF-30100CU-XX-01-XX-XX
-042	2.788[70.80]	QCD-03-03	SUB-EQDP-X-042-03-XX		
-056	3.575[90.80]	QCD-04-03	SUB-EQDP-X-056-03-XX		

4-40 THD REF (TYP) SUB-QCD-XX-03-BULK

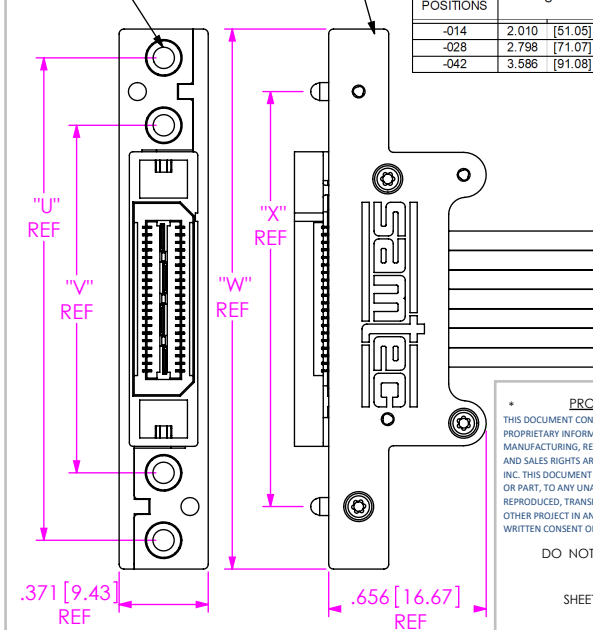

**TABLE 10**

No. OF POSITIONS	"U"	"V"	"W"	"X"	SUB-QCD-XXX-03-BULK	WIRING OPTION	
						-1, -2, -3, -4	-5, -6, -7, -8
-014	2.010 [51.05]	1.449 [36.80]	2.250 [57.15]	1.73 [43.94]	SUB-QCD-01-03-BULK	SUB-TTF-30100XX-XX-XX-XX	SUB-TTF-30100CU-XX-01-XX-XX
-028	2.798 [71.07]	2.237 [56.82]	3.038 [77.17]	2.518 [63.96]	SUB-QCD-02-03-BULK		
-042	3.586 [91.08]	3.024 [76.81]	3.826 [97.18]	3.306 [83.97]	SUB-QCD-03-03-BULK		

**FIG. 7**

PANEL MOUNT (BULK HEAD SCREW INSERTS)  
(EQDP-014-XX.XX-SPU-XXX-X SHOWN)  
(SAME AS FIG. 2, UNLESS OTHERWISE STATED)

PROPRIETARY NOTE  
THIS DOCUMENT CONTAINS CONFIDENTIAL AND PROPRIETARY INFORMATION AND ALL DESIGN, MANUFACTURING, REPRODUCTION, USE, PATENT RIGHTS AND SALES RIGHTS ARE EXPRESSLY RESERVED BY SAMTEC, INC. THIS DOCUMENT SHALL NOT BE DISCLOSED, IN WHOLE OR PART, TO ANY UNAUTHORIZED PERSON OR ENTITY NOR REPRODUCED, TRANSFERRED OR INCORPORATED IN ANY OTHER PROJECT IN ANY MANNER WITHOUT THE EXPRESS WRITTEN CONSENT OF SAMTEC, INC.

DO NOT SCALE DRAWING

SHEET SCALE: 1:25:1



520 PARK EAST BLVD, NEW ALBANY, IN 47150  
PHONE: 812-944-6733 FAX: 812-948-5047  
e-Mail: info@SAMTEC.com code: 53322

DESCRIPTION:  
0.8mm HIGH-SPEED TWIN-AX CABLE ASSEMBLY

DWG. NO.  
EQDP-XXX-XX.XX-XXX-XXX-X-X

BY: BRATCHER 11/13/03 SHEET 6 OF 9



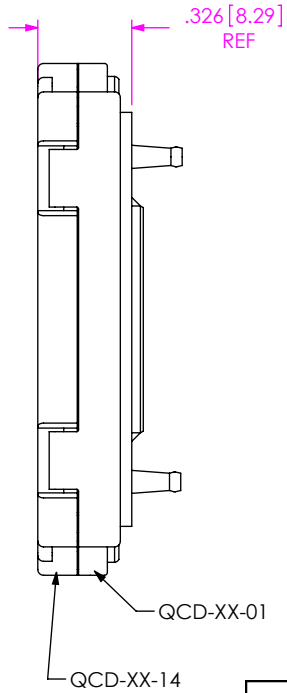

FIG 6  
(EQDP-014-XX.X-STL-TTR-1-D SHOWN)  
(SAME AS FIG 1, UNLESS OTHERWISE STATED)

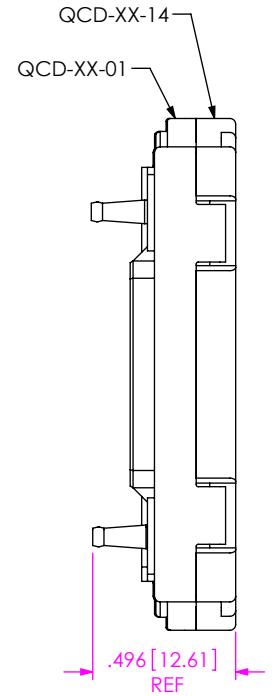
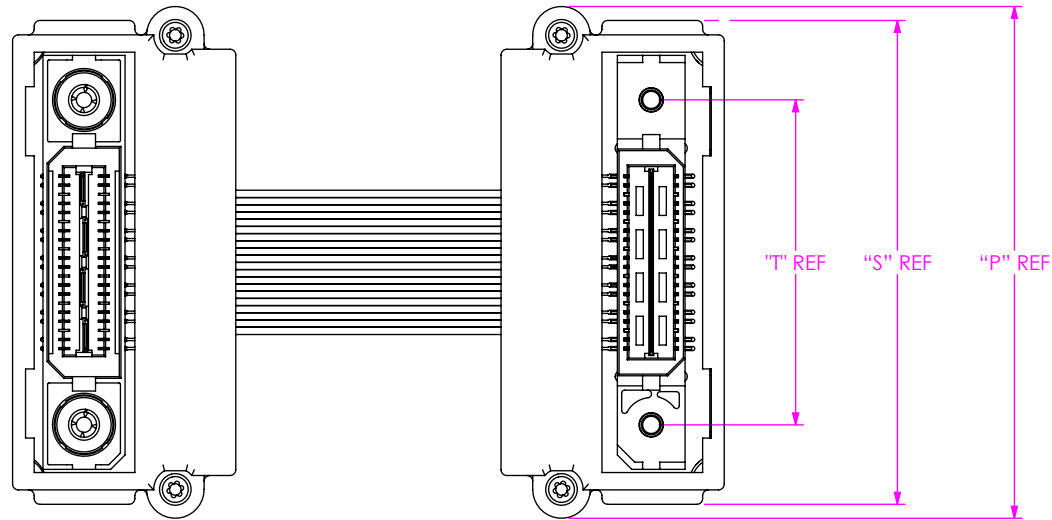

TABLE 11

No. OF POSITIONS	"P"	"S"	"T"	QCD-XX-01	QCD-XX-14	SUB-EQDP-X-XXX-XX-XX-RT1	WIRING OPTION	
							-1, -2, -3, -4	-5, -6, -7, -8
-014	1.777 [45.14]	1.680 [42.67]	1.129 [28.68]	QCD-07-01	QCD-01-14	SUB-EQDP-X-014-XX-XX-RT1	SUB-TTF-30100XX-XX-XX-XX-XX	SUB-TTF-30100CU-XX-01-XX-XX
-028	2.565 [65.15]	2.468 [62.69]	1.916 [48.67]	QCD-08-01	QCD-02-14	SUB-EQDP-X-028-XX-XX-RT1		
-042	3.352 [85.14]	3.255 [82.68]	2.704 [68.68]	QCD-09-01	QCD-03-14	SUB-EQDP-X-042-XX-XX-RT1		
-056	4.140 [105.16]	4.043 [102.69]	3.491 [88.67]	QCD-10-01	QCD-04-14	SUB-EQDP-X-056-XX-XX-RT1		

FIG 5  
(EQDP-014-XX.XX-TEU-STR-N SHOWN)  
(SAME AS FIG 1, UNLESS OTHERWISE STATED)

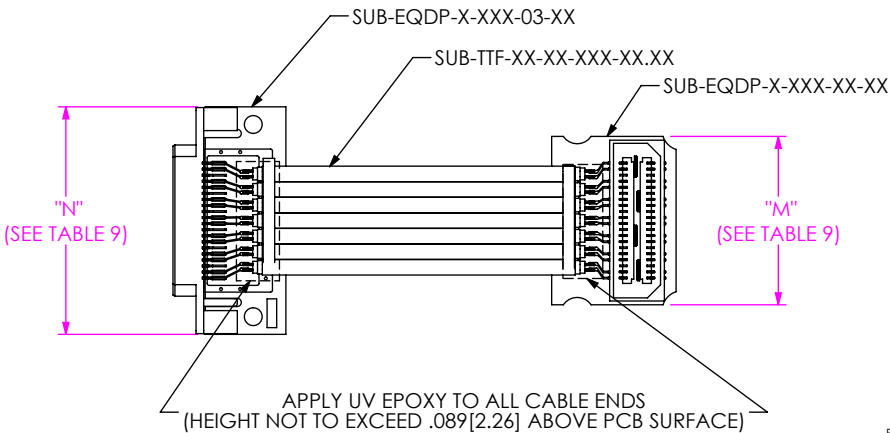

TABLE 12

No. OF POSITIONS	"M"	"N"	WIRING OPTION	
			-1, -2, -3, -4	-5, -6, -7, -8
-014	.877 [22.28]	1.185 [30.10]	SUB-TTF-30100XX-XX-XX-XX-XX	SUB-TTF-30100CU-XX-01-XX-XX
-028	1.665 [42.28]	1.973 [50.10]		
-042	2.452 [62.28]	2.760 [70.10]		
-056	3.240 [82.28]	3.548 [90.10]		

**PROPRIETARY NOTE**  
THIS DOCUMENT CONTAINS CONFIDENTIAL AND PROPRIETARY INFORMATION AND ALL DESIGN, MANUFACTURING, REPRODUCTION, USE, PATENT RIGHTS AND SALES RIGHTS ARE EXPRESSLY RESERVED BY SAMTEC, INC. THIS DOCUMENT SHALL NOT BE DISCLOSED, IN WHOLE OR PART, TO ANY UNAUTHORIZED PERSON OR ENTITY NOR REPRODUCED, TRANSFERRED OR INCORPORATED IN ANY OTHER PROJECT IN ANY MANNER WITHOUT THE EXPRESS WRITTEN CONSENT OF SAMTEC, INC.

DO NOT SCALE DRAWING  
SHEET SCALE: 2:1



520 PARK EAST BLVD, NEW ALBANY, IN 47150  
PHONE: 812-944-6733 FAX: 812-948-5047  
e-Mail: info@SAMTEC.com code: 55322

DESCRIPTION:  
0.8mm HIGH-SPEED TWIN-AX CABLE ASSEMBLY  
DWG. NO.  
EQDP-XXX-XX.XX-XXX-XXX-X-X  
BY: BRATCHER 11/13/03 SHEET 7 OF 9





TABLE 9 (2)

FIRST END OPTION	FIRST END SUB-EQDP-X-XXX-XX-01	WIRING OPTION	FIRST END PIN #	SECOND END PIN #	WIRE #	SECOND END OPTION (SUB-EQDP-X-XXX-XX-XX)											
						-TTR	-TTL	-TBR	-TBL	-STR	-STL	-SBR	-SBL	-TEU / TPU	-TED / TPD	-SEU / SPU	-SED / SPD
-TTR	-T-XXX-01-01	5	1	1	B14	-T-XXX-02-02	N/A	N/A	-T-XXX-01-02	N/A	-S-XXX-01-01	-S-XXX-02-01	N/A	N/A	-T-XXX-03-02	-S-XXX-03-01	N/A
		6	1	2	B14	-T-XXX-02-01	N/A	N/A	-T-XXX-01-01	N/A	-S-XXX-01-02	-S-XXX-02-02	N/A	N/A	-T-XXX-03-01	-S-XXX-03-02	N/A
		7	1	N-1	B14	N/A	-T-XXX-01-01	-T-XXX-02-01	N/A	-S-XXX-02-02	N/A	N/A	-S-XXX-01-02	-T-XXX-03-01	N/A	N/A	-S-XXX-03-02
-TTL	-T-XXX-02-01	5	1	1	T1	-T-XXX-01-02	-T-XXX-02-02	N/A	-S-XXX-02-01	N/A	N/A	-S-XXX-01-01	-T-XXX-03-02	N/A	N/A	-S-XXX-03-01	N/A
		6	1	2	T1	N/A	-T-XXX-01-01	-T-XXX-02-01	N/A	-S-XXX-02-02	N/A	N/A	-S-XXX-01-02	-T-XXX-03-01	N/A	N/A	-S-XXX-03-02
		7	1	N-1	T1	-T-XXX-02-01	N/A	N/A	-T-XXX-01-01	N/A	-S-XXX-01-02	-S-XXX-02-02	N/A	N/A	-T-XXX-03-01	-S-XXX-03-02	N/A
-TBR	-T-XXX-01-01	5	1	1	T1	N/A	-T-XXX-01-02	-T-XXX-02-02	N/A	-S-XXX-02-01	N/A	N/A	-S-XXX-01-01	-T-XXX-03-02	N/A	N/A	-S-XXX-03-01
		6	1	2	T1	N/A	-T-XXX-01-01	-T-XXX-02-01	N/A	-S-XXX-02-02	N/A	N/A	-S-XXX-01-02	-T-XXX-03-01	N/A	N/A	-S-XXX-03-02
		7	1	N-1	T1	-T-XXX-02-01	N/A	N/A	-T-XXX-01-01	N/A	-S-XXX-01-02	-S-XXX-02-02	N/A	N/A	-T-XXX-03-01	-S-XXX-03-02	N/A
-TBL	-T-XXX-02-01	5	1	1	B14	-T-XXX-02-02	N/A	N/A	-T-XXX-01-02	N/A	-S-XXX-01-01	-S-XXX-02-01	N/A	N/A	-T-XXX-03-02	-S-XXX-03-01	N/A
		6	1	2	B14	-T-XXX-02-01	N/A	N/A	-T-XXX-01-01	N/A	-S-XXX-01-02	-S-XXX-02-02	N/A	N/A	-T-XXX-03-01	-S-XXX-03-02	N/A
		7	1	N-1	B14	N/A	-T-XXX-01-01	-T-XXX-02-01	N/A	-S-XXX-02-02	N/A	N/A	-S-XXX-01-02	-T-XXX-03-01	N/A	N/A	-S-XXX-03-02
-STR	-S-XXX-01-01	5	1	1	B1	-T-XXX-01-01	-T-XXX-02-01	N/A	-S-XXX-02-02	N/A	N/A	-S-XXX-01-01	-T-XXX-03-02	N/A	N/A	-S-XXX-03-01	N/A
		6	1	2	B1	N/A	-T-XXX-01-02	-T-XXX-02-02	N/A	-S-XXX-02-01	N/A	N/A	-S-XXX-01-01	-T-XXX-03-01	N/A	N/A	-S-XXX-03-02
		7	1	N-1	B1	-T-XXX-02-02	N/A	N/A	-T-XXX-01-02	N/A	-S-XXX-01-01	-S-XXX-02-01	N/A	N/A	-T-XXX-03-02	-S-XXX-03-01	N/A
-STL	-S-XXX-02-01	5	1	1	T14	-T-XXX-02-01	N/A	N/A	-T-XXX-01-01	N/A	-S-XXX-01-02	-S-XXX-02-02	N/A	N/A	-T-XXX-03-01	-S-XXX-03-02	N/A
		6	1	2	T14	-T-XXX-02-02	N/A	N/A	-T-XXX-01-02	N/A	-S-XXX-01-01	-S-XXX-02-01	N/A	N/A	-T-XXX-03-02	-S-XXX-03-01	N/A
		7	1	N-1	T14	N/A	-T-XXX-01-02	-T-XXX-02-02	N/A	-S-XXX-02-01	N/A	N/A	-S-XXX-01-01	-T-XXX-03-02	N/A	N/A	-S-XXX-03-01
-SBR	-S-XXX-01-01	5	1	1	T14	-T-XXX-02-01	N/A	N/A	-T-XXX-01-01	N/A	-S-XXX-01-02	-S-XXX-02-02	N/A	N/A	-T-XXX-03-01	-S-XXX-03-02	N/A
		6	1	2	T14	-T-XXX-02-02	N/A	N/A	-T-XXX-01-02	N/A	-S-XXX-01-01	-S-XXX-02-01	N/A	N/A	-T-XXX-03-02	-S-XXX-03-01	N/A
		7	1	N-1	T14	N/A	-T-XXX-01-02	-T-XXX-02-02	N/A	-S-XXX-02-01	N/A	N/A	-S-XXX-01-01	-T-XXX-03-02	N/A	N/A	-S-XXX-03-01
-SBL	-S-XXX-02-01	5	1	1	B1	-T-XXX-01-01	-T-XXX-02-01	N/A	-S-XXX-02-02	N/A	N/A	-S-XXX-01-01	-T-XXX-03-01	N/A	N/A	-S-XXX-03-02	N/A
		6	1	2	B1	N/A	-T-XXX-01-02	-T-XXX-02-02	N/A	-S-XXX-02-01	N/A	N/A	-S-XXX-01-01	-T-XXX-03-02	N/A	N/A	-S-XXX-03-01
		7	1	N-1	B1	-T-XXX-02-02	N/A	N/A	-T-XXX-01-02	N/A	-S-XXX-01-01	-S-XXX-02-01	N/A	N/A	-T-XXX-03-01	-S-XXX-03-02	N/A
-TEU	-T-XXX-03-01	5	1	1	B14	-T-XXX-02-02	N/A	N/A	-T-XXX-01-01	N/A	-S-XXX-01-01	-S-XXX-02-01	N/A	N/A	-T-XXX-03-02	-S-XXX-03-01	N/A
		6	1	2	B14	-T-XXX-02-01	N/A	N/A	-T-XXX-01-01	N/A	-S-XXX-01-02	-S-XXX-02-02	N/A	N/A	-T-XXX-03-01	-S-XXX-03-02	N/A
		7	1	N-1	B14	N/A	-T-XXX-01-01	-T-XXX-02-01	N/A	-S-XXX-02-02	N/A	N/A	-S-XXX-01-02	-T-XXX-03-01	N/A	N/A	-S-XXX-03-02
-TED	-T-XXX-03-01	5	1	1	T1	-T-XXX-01-02	-T-XXX-02-02	N/A	-S-XXX-02-01	N/A	N/A	-S-XXX-01-01	-T-XXX-03-02	N/A	N/A	-S-XXX-03-01	N/A
		6	1	2	T1	N/A	-T-XXX-01-01	-T-XXX-02-01	N/A	-S-XXX-02-02	N/A	N/A	-S-XXX-01-02	-T-XXX-03-01	N/A	N/A	-S-XXX-03-02
		7	1	N-1	T1	-T-XXX-02-01	N/A	N/A	-T-XXX-01-01	N/A	-S-XXX-01-02	-S-XXX-02-02	N/A	N/A	-T-XXX-03-01	-S-XXX-03-02	N/A
-SEU	-S-XXX-03-01	5	1	1	B1	-T-XXX-01-01	-T-XXX-02-01	N/A	-S-XXX-02-02	N/A	N/A	-S-XXX-01-01	-T-XXX-03-01	N/A	N/A	-S-XXX-03-02	N/A
		6	1	2	B1	N/A	-T-XXX-01-02	-T-XXX-02-02	N/A	-S-XXX-02-01	N/A	N/A	-S-XXX-01-01	-T-XXX-03-02	N/A	N/A	-S-XXX-03-01
		7	1	N-1	B1	-T-XXX-02-02	N/A	N/A	-T-XXX-01-02	N/A	-S-XXX-01-01	-S-XXX-02-01	N/A	N/A	-T-XXX-03-01	-S-XXX-03-02	N/A
-SED	-S-XXX-03-01	5	1	1	T14	-T-XXX-02-01	N/A	N/A	-T-XXX-01-01	N/A	-S-XXX-01-02	-S-XXX-02-02	N/A	N/A	-T-XXX-03-01	-S-XXX-03-02	N/A
		6	1	2	T14	-T-XXX-02-02	N/A	N/A	-T-XXX-01-02	N/A	-S-XXX-01-01	-S-XXX-02-01	N/A	N/A	-T-XXX-03-02	-S-XXX-03-01	N/A
		7	1	N-1	T14	N/A	-T-XXX-01-02	-T-XXX-02-02	N/A	-S-XXX-02-01	N/A	N/A	-S-XXX-01-01	-T-XXX-03-02	N/A	N/A	-S-XXX-03-01
-TPU	-T-XXX-03-01	5	1	1	B14	-T-XXX-02-02	N/A	N/A	-T-XXX-01-02	N/A	-S-XXX-01-01	-S-XXX-02-01	N/A	N/A	-T-XXX-03-02	-S-XXX-03-01	N/A
		6	1	2	B14	-T-XXX-02-01	N/A	N/A	-T-XXX-01-01	N/A	-S-XXX-01-02	-S-XXX-02-02	N/A	N/A	-T-XXX-03-01	-S-XXX-03-02	N/A
		7	1	N-1	B14	N/A	-T-XXX-01-01	-T-XXX-02-01	N/A	-S-XXX-02-02	N/A	N/A	-S-XXX-01-02	-T-XXX-03-01	N/A	N/A	-S-XXX-03-02
-TPD	-T-XXX-03-01	5	1	1	T1	N/A	-T-XXX-01-02	-T-XXX-02-02	N/A	-S-XXX-02-01	N/A	N/A	-S-XXX-01-01	-T-XXX-03-02	N/A	N/A	-S-XXX-03-01
		6	1	2	T1	N/A	-T-XXX-01-01	-T-XXX-02-01	N/A	-S-XXX-02-02	N/A	N/A	-S-XXX-01-02	-T-XXX-03-01	N/A	N/A	-S-XXX-03-02
		7	1	N-1	T1	-T-XXX-02-01	N/A	N/A	-T-XXX-01-01	N/A	-S-XXX-01-02	-S-XXX-02-02	N/A	N/A	-T-XXX-03-01	-S-XXX-03-02	N/A
-SPU	-S-XXX-03-01	5	1	1	B1	N/A	-T-XXX-01-01	-T-XXX-02-01	N/A	-S-XXX-02-02	N/A	N/A	-S-XXX-01-01	-T-XXX-03-01	N/A	N/A	-S-XXX-03-02
		6	1	2	B1	N/A	-T-XXX-01-02	-T-XXX-02-02	N/A	-S-XXX-02-01	N/A	N/A	-S-XXX-01-01	-T-XXX-03-02	N/A	N/A	-S-XXX-03-01
		7	1	N-1	B1	-T-XXX-02-02	N/A	N/A	-T-XXX-01-02	N/A	-S-XXX-01-01	-S-XXX-02-01	N/A	N/A	-T-XXX-03-01	-S-XXX-03-02	N/A
-SPD	-S-XXX-03-01	5	1	1	T14	-T-XXX-02-01	N/A	N/A	-T-XXX-01-01	N/A	-S-XXX-01-02	-S-XXX-02-02	N/A	N/A	-T-XXX-03-01	-S-XXX-03-02	N/A
		6	1	2	T14	-T-XXX-02-02	N/A	N/A	-T-XXX-01-02	N/A	-S-XXX-01-01	-S-XXX-02-01	N/A	N/A	-T-XXX-03-02	-S-XXX-03-01	N/A
		7	1	N-1	T14	N/A	-T-XXX-01-02	-T-XXX-02-02	N/A	-S-XXX-02-01	N/A	N/A	-S-XXX-01-01	-T-XXX-03-02	N/A	N/A	-S-XXX-03-01
8	1	N	T14	N/A	-T-XXX-01-01	-T-XXX-02-01	N/A	-S-XXX-02-02	N/A	N/A	-S-XXX-01-02	-T-XXX-03-01	N/A	N/A	-S-XXX-03-02		

FOR RT1 OPTION SUB-ASSEMBLY ADD -RT1 TO THE END OF THE SUB-ASSEMBLY CALLOUT LISTED IN THE TABLE ABOVE.

**PROPRIETARY NOTE**  
 THIS DOCUMENT CONTAINS CONFIDENTIAL AND PROPRIETARY INFORMATION AND ALL DESIGN, MANUFACTURING, REPRODUCTION, USE, PATENT RIGHTS AND SALES RIGHTS ARE EXPRESSLY RESERVED BY SAMTEC, INC. THIS DOCUMENT SHALL NOT BE DISCLOSED, IN WHOLE OR PART, TO ANY UNAUTHORIZED PERSON OR ENTITY NOR REPRODUCED, TRANSFERRED OR INCORPORATED IN ANY OTHER PROJECT IN ANY MANNER WITHOUT THE EXPRESS WRITTEN CONSENT OF SAMTEC, INC.



520 PARK EAST BLVD, NEW ALBANY, IN 47150  
 PHONE: 812-944-6733 FAX: 812-948-5047  
 e-Mail: info@SAMTEC.com code: 55322

DO NOT SCALE DRAWING

SHEET SCALE: 1.25:1

DESCRIPTION:  
 0.8mm HIGH-SPEED TWIN-AX CABLE ASSEMBLY

DWG. NO.  
 EQDP-XXX-XX.XX-XXX-XXX-X-X

BY: BRATCHER 11/13/03 SHEET 9 OF 9