

REVISIONS			
REV.	DESCRIPTION	DATE	APPROVED
A	ECO #7461	02/24/09	M.J.

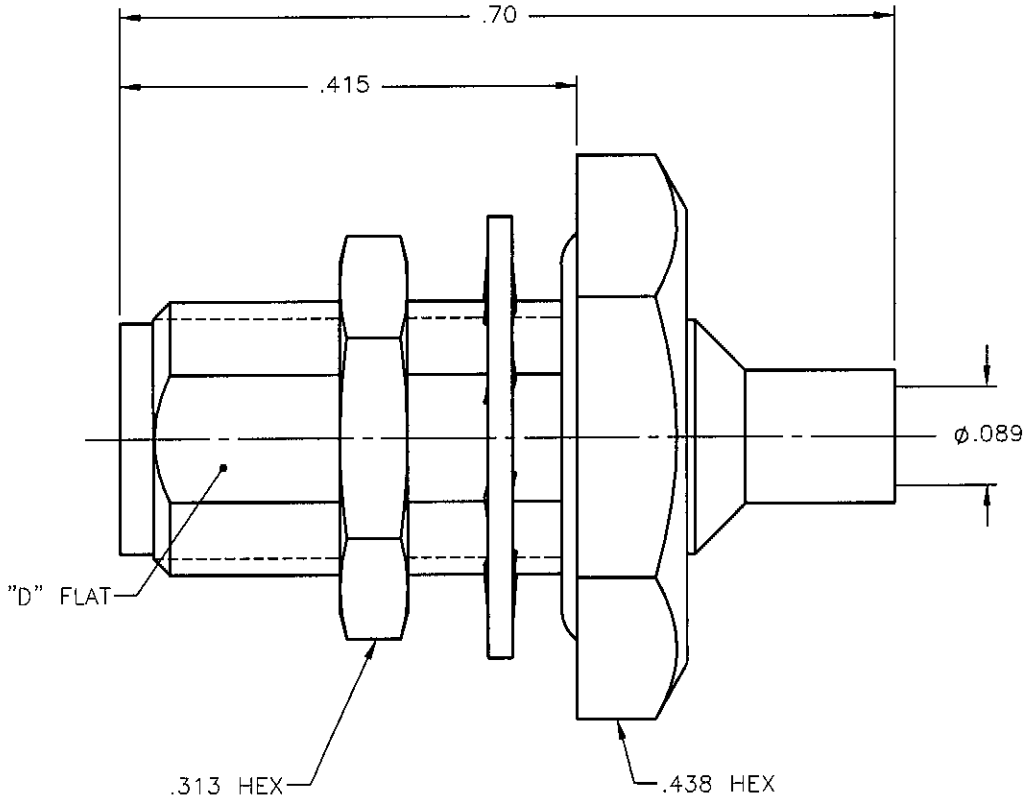

NOTES:

MATERIALS:

1. BODY & NUT = STAINLESS STEEL PER ASTM A582, ALLOY 303, CONDITION "A".
2. CONTACT = BERYLLIUM COPPER PER ASTM B196, ALLOY C17300, TEMPER TD04.
3. INSULATOR = VIRGIN WHITE TEFLON PER ASTM D1710, GRADE 1, TYPE I, CLASS "B".
4. LOCKWASHER = PHOSPHOR BRONZE PER ASTM B139, COPPER ALLOY C53400, TEMPER H04.
5. "O" RING = SILICONE RUBBER PER ZZ-R-765, CLASS 2B, GRADE 65-75.

FINISHES:

1. CONTACT = GOLD PLATE PER MIL-G-45204, TYPE II, CLASS 1, GRADE C,
OVER .00010 TO .00020 STRESS FREE SULFAMATE NICKEL PER QQ-N-290.
2. ALL OTHER METAL PARTS = GOLD PLATE PER MIL-G-45204, TYPE II, CLASS 0, GRADE C,
OVER .000050 TO .00010 STRESS FREE NICKEL PER QQ-N-290.

Property of Radiall Incorporated
This document cannot be reproduced or
communicated to a third party without prior
written permission of RADIALL Incorporated.

UNLESS OTHERWISE SPECIFIED DIMENSIONS ARE IN INCHES TOLERANCES ON	DWN: M.J.	DATE 02/24/09	 APPLIED ENGINEERING PRODUCTS 104 John W. Murphy Dr. New Haven, CT 06513			
	CHKD:	DATE 02/24/09				
DECIMAL	ANGLE	D.N.	SMA STRAIGHT JACK BULKHEAD DIRECT SOLDER TYPE FOR .085 S/R CABLE			
		APVD: J.M.				DATE 02/24/09
REFERENCE:	MATERIALS & FINISHES: SEE NOTES		SIZE A	FSCM NO. 19505	DWG NO. 9453-1583-010	REV A
ORIGINATED: D.N. DATE: 06/13/83			SCALE 6:1	THIRD ANGLE PROJECTION	SHEET 1 OF 1	

9453-1583-010