

THIS DRAWING IS UNPUBLISHED. RELEASED FOR PUBLICATION
 © COPYRIGHT - By - ALL RIGHTS RESERVED.

| LOC | DIST | REVISIONS | | | | | |
|-----|------|-----------|-----|---------------------------|-----------|-----|------|
| | | P | LTR | DESCRIPTION | DATE | DWN | APVD |
| | | | B3 | REVISED PER ECO-14-016628 | 04NOV2014 | NK | DR |

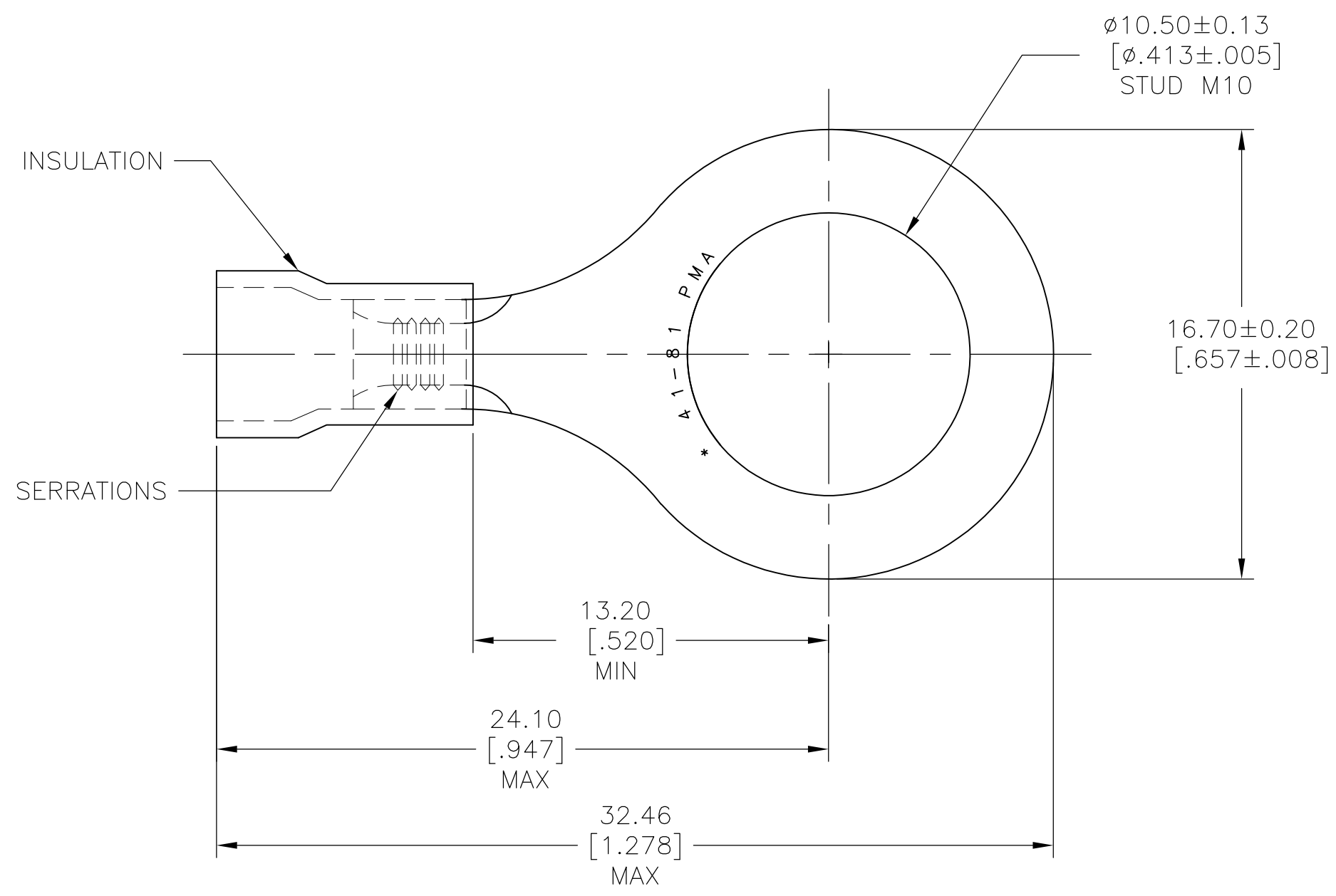

- 1 COPPER PER ASTM B152
INSULATION: PVC, BLUE.
- 2 TIN PLATED PER ASTM B545.
- 3 FOR 3.00[.118] TO 4.90[.193]
MAX INSULATION DIAMETER.

| | | |
|-----|--------------|---------|
| 500 | LOOSE PIECE | 160136 |
| QTY | PACKAGE TYPE | PART NO |

| | | | | | | | | | | | | | | | | |
|--|-----|---------------------------------|--|------------------------|-----|-------|-----|-------|-----|-------|-----|--------|-----|-------------------|------------|--|
| THIS DRAWING IS A CONTROLLED DOCUMENT. | | DWN KIRAN HOLAL 06FEB12 | STE TE Connectivity | | | | | | | | | | | | | |
| DIMENSIONS: mm [INCHES] | | CHK ROHDE DANIEL 06FEB12 | | | | | | | | | | | | | | |
| TOLERANCES UNLESS OTHERWISE SPECIFIED: | | APVD ROHDE DANIEL 06FEB12 | NAME TERMINAL, RING TONGUE PLASTI-GRIP WIRE SIZE:16-14 AWG | | | | | | | | | | | | | |
| <table border="0"> <tr><td>0 PLC</td><td>± -</td></tr> <tr><td>1 PLC</td><td>± -</td></tr> <tr><td>2 PLC</td><td>± -</td></tr> <tr><td>3 PLC</td><td>± -</td></tr> <tr><td>4 PLC</td><td>± -</td></tr> <tr><td>ANGLES</td><td>± -</td></tr> </table> | | 0 PLC | ± - | 1 PLC | ± - | 2 PLC | ± - | 3 PLC | ± - | 4 PLC | ± - | ANGLES | ± - | PRODUCT SPEC - | SIZE A3 | |
| 0 PLC | ± - | | | | | | | | | | | | | | | |
| 1 PLC | ± - | | | | | | | | | | | | | | | |
| 2 PLC | ± - | | | | | | | | | | | | | | | |
| 3 PLC | ± - | | | | | | | | | | | | | | | |
| 4 PLC | ± - | | | | | | | | | | | | | | | |
| ANGLES | ± - | | | | | | | | | | | | | | | |
| MATERIAL | | APPLICATION SPEC - | CAGE CODE 00779 | DRAWING NO C-160136 | | | | | | | | | | | | |
| FINISH | | WEIGHT - | RESTRICTED TO - | | | | | | | | | | | | | |
| 1 | | 2 | | SCALE 5:1 | | | | | | | | | | | | |
| CUSTOMER DRAWING | | | SHEET 1 OF 1 | REV B3 | | | | | | | | | | | | |