

FAA/PMA

REV.	DESCRIPTION	DATE	APPROVED
H	33697 REDRAWN, FIND NOS 5 & 6 ADDED	97/09/12	RS

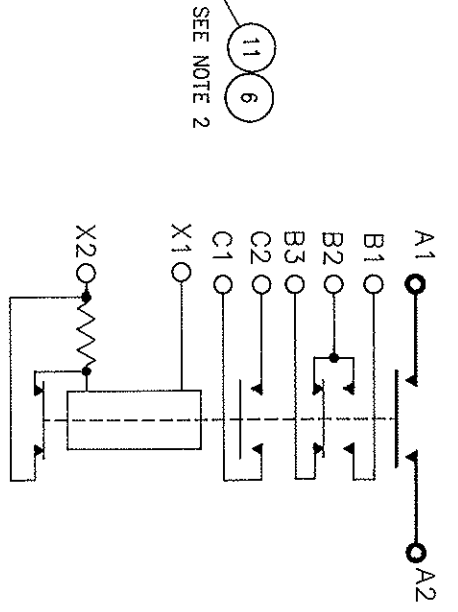
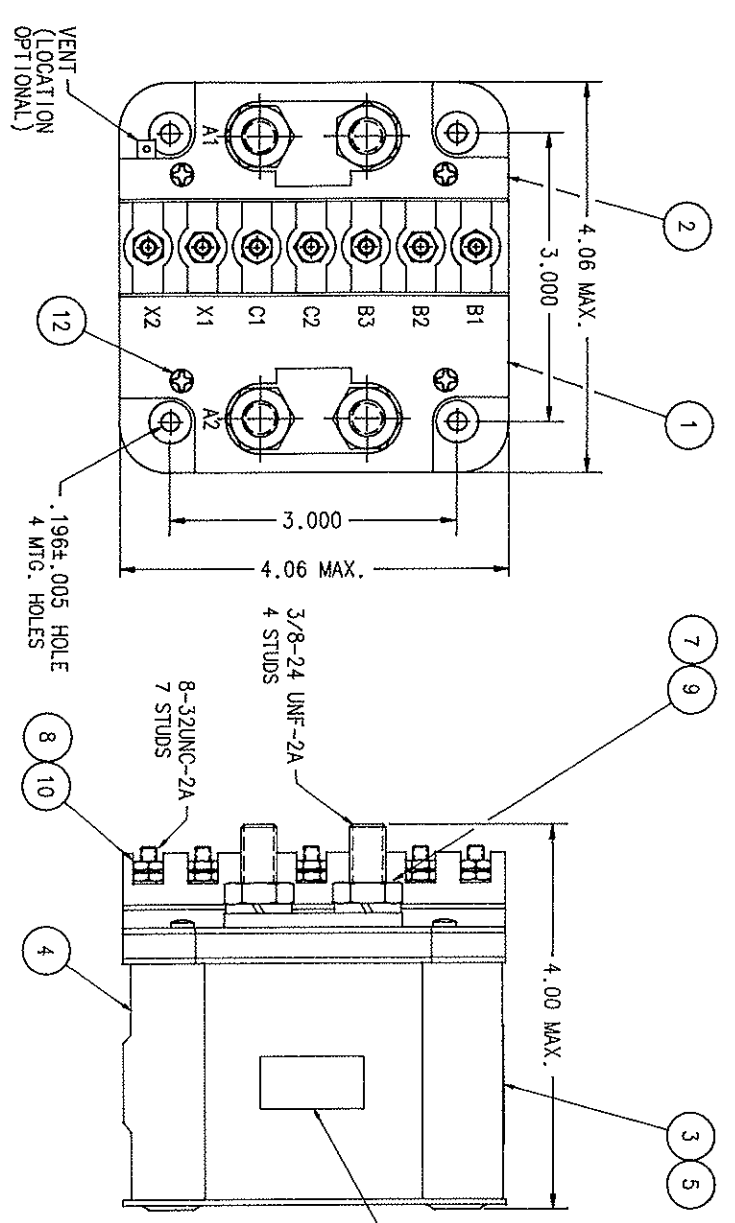

- NOTES:
1. MEETS THE APPLICABLE PORTIONS OF MIL-C-5026
 2. WHEN REQUIRED BY CUSTOMER

MAXIMUM OPERATING VOLTAGE 29 VOLTS
 PICKUP VOLTAGE 18 VOLTS MAX
 DROPOUT VOLTAGE 7 +0 -5.5 VOLTS MAX
 RATED LOAD, RESISTIVE 600 AMPS
 COIL CURRENT AT 29V & 25°C .6 AMP
 MINIMUM OPERATING CYCLES 50,000
 MAXIMUM WEIGHT 3 LBS 3 OZ
 RATED DUTY OF COIL CONTINUOUS
 NOMINAL COIL VOLTAGE 24-28 VOLTS
 AUX CONTACT RATING 5 AMP

QTY	PART OR IDENTIFYING NO	NOMENCLATURE OR DESCRIPTION	FSM NO	DRAWING OR SPECIFICATION	MATERIAL OR NOTE
4	51200-020	SCREW No. 4 x 1/4 PAN HD. SHI MET.			S. STEEL
1	58400-062	PLATE - FAA/PMA			
7	51808-064	WASHER - LOCK No. 8 SPLIT			BRONZE
4	51807-084	WASHER - LOCK 3/8 SPLIT			BRONZE
7	50408-034	NUT No. 8-32 X 5/16 X 3/32 HEX			BRASS
4	50407-164	NUT 3/8-24 X 5/8 X 7/32 HEX			BRASS
1	39529-024	OVERLAY			
1	39529-001	OVERLAY			
1	40027-010	CONTACTOR ASSEMBLY-PRIMARY			
1	16043-001	PLATE - NAME			
1	13328-001	PLATE - BASE COVER			
1	13325-004	PLATE - BASE COVER			

UNLESS OTHERWISE SPECIFIED TOLERANCES ARE IN INCHES
 2 PL DEC. 13 PL DEC. ANGLES
 * .03 * .010 * 1*

DR BY RLS 97/10/02
 CHK BY RS 97/10/02
 ENGR DM 9/11/07
 MFG CC 4/7/07

RELEASE
 CONTR NO.
 GOVT APPLV

HARTMAN ELECTRICAL MANUFACTURING
 MANSFIELD, OHIO

CONTACTOR-CONTINUOUS
 DUTY, 600 AMP

SIZE C CODE IDENT DWG NO. A-712W
 SCALE 1:2 SHEET

12	4	51200-020	SCREW No. 4 x 1/4 PAN HD. SHI MET.		S. STEEL
11	1	58400-062	PLATE - FAA/PMA		
10	7	51808-064	WASHER - LOCK No. 8 SPLIT		BRONZE
9	4	51807-084	WASHER - LOCK 3/8 SPLIT		BRONZE
8	7	50408-034	NUT No. 8-32 X 5/16 X 3/32 HEX		BRASS
7	4	50407-164	NUT 3/8-24 X 5/8 X 7/32 HEX		BRASS
6	1	39529-024	OVERLAY		
5	1	39529-001	OVERLAY		
4	1	40027-010	CONTACTOR ASSEMBLY-PRIMARY		
3	1	16043-001	PLATE - NAME		
2	1	13328-001	PLATE - BASE COVER		
1	1	13325-004	PLATE - BASE COVER		