

## UC1845A-SP QML class V, radiation hardened current-mode PWM controller

### 1 Features

- QML Class V (QMLV) Qualified, SMD 5962-86704
- 5962P8670411Vxx: <sup>(1)</sup>
  - Radiation Hardness Assurance (RHA) up to 30-krad(Si) Total Ionizing Dose (TID)
  - Passes Functional and Specified Post-Radiation Parametric Limits at 45 krad at LDR (10 mrad(Si)/s) per 1.5x Over Test as Defined in MIL-STD-883 Test Method 1019.9 Paragraph 3.13.3.b
  - Exhibits Low Dose Rate Sensitivity <sup>(2)</sup> but Remains Within the Pre-Radiation Electrical Limits at 30-krad Total Dose Level, as Allowed by MIL-STD-883, TM1019
- Optimized for DC-to-DC Converter Applications
- Low Start-Up Current (< 0.5 mA)
- Trimmed Oscillator Discharge Current
- Automatic Feed Forward Compensation
- Pulse-by-Pulse Current Limiting
- Enhanced Load Response Characteristics
- Undervoltage Lockout (UVLO) With Hysteresis
- Double-Pulse Suppression
- High-Current Totem-Pole Output
- Internally-Trimmed Bandgap Reference
- 500-kHz Operation
- Low  $R_O$  Error Amplifier
- Qualified Over the Military Temperature Range ( $-55^{\circ}\text{C}$  to  $125^{\circ}\text{C}$ )

- (1) Improved TID radiation performance only applies to RHA device type 11.
- (2) The affected parameter Reference Output Voltage,  $V_{REF}$  Radiation Drift Curve (see [VREF Radiation Drift Curve](#)).

### 2 Applications

- Radiation-Hardened DC-DC Converters
- Satellite Buses and Payloads
- Space Launch Vehicles
- Undersea Cabling
- Supports Various Topologies:
  - Flyback, Forward, Buck, Boost
  - Push-Pull, Half-Bridge, Full-Bridge With External Interface Circuit

### 3 Description

The UC1845A-SP control IC is a radiation hardened pin-for-pin compatible version of the UC184x family. It is primarily suited for Satellites and other harsh environment applications. Providing the necessary characteristics to control current-mode switched-mode power supplies, this device has improved features. Start-up current is specified to be less than 0.5 mA and oscillator discharge is trimmed to 8.3 mA. During UVLO, the output stage can sink at least 10 mA at less than 1.2 V for  $V_{CC}$  over 5 V.

The *Device Comparison Table* shows the difference between members of this family. Reference the individual product data sheets for ordering the radiation-improved version if available.

#### Device Information<sup>(1)</sup>

PART NUMBER	PACKAGE	BODY SIZE (NOM)
UC1845A-SP	CDIP/JG (8)	6.67 mm x 9.60 mm
	LCCC/FK (20)	8.89 mm x 8.89 mm
	CFP/HKU (10)	6.48 mm x 7.02 mm

- (1) For all available packages, see the orderable addendum at the end of the data sheet.

#### Simplified Schematic

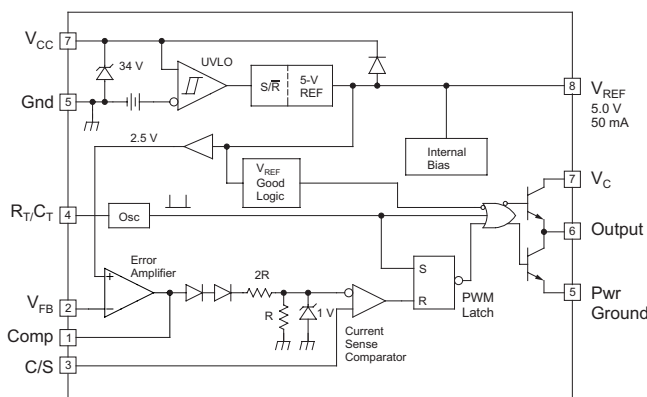

#### $V_{REF}$ Radiation Drift Curve

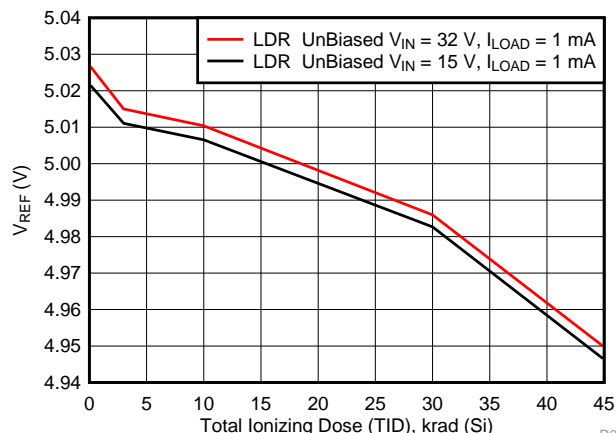

D001



## Table of Contents

<b>1 Features</b> .....	<b>1</b>	8.3 Feature Description.....	<b>7</b>
<b>2 Applications</b> .....	<b>1</b>	8.4 Device Functional Modes.....	<b>12</b>
<b>3 Description</b> .....	<b>1</b>	<b>9 Application and Implementation</b> .....	<b>13</b>
<b>4 Revision History</b> .....	<b>2</b>	9.1 Application Information.....	<b>13</b>
<b>5 Device Comparison Table</b> .....	<b>3</b>	9.2 Typical Application .....	<b>13</b>
<b>6 Pin Configuration and Functions</b> .....	<b>3</b>	<b>10 Power Supply Recommendations</b> .....	<b>20</b>
<b>7 Specifications</b> .....	<b>4</b>	<b>11 Layout</b> .....	<b>20</b>
7.1 Absolute Maximum Ratings .....	<b>4</b>	11.1 Layout Guidelines .....	<b>20</b>
7.2 ESD Ratings.....	<b>4</b>	11.2 Layout Example .....	<b>21</b>
7.3 Recommended Operating Conditions.....	<b>4</b>	<b>12 Device and Documentation Support</b> .....	<b>22</b>
7.4 Thermal Information .....	<b>4</b>	12.1 Receiving Notification of Documentation Updates	<b>22</b>
7.5 Electrical Characteristics.....	<b>5</b>	12.2 Community Resources.....	<b>22</b>
7.6 Typical Characteristics.....	<b>6</b>	12.3 Trademarks .....	<b>22</b>
<b>8 Detailed Description</b> .....	<b>7</b>	12.4 Electrostatic Discharge Caution.....	<b>22</b>
8.1 Overview .....	<b>7</b>	12.5 Glossary .....	<b>22</b>
8.2 Functional Block Diagram .....	<b>7</b>	<b>13 Mechanical, Packaging, and Orderable Information</b> .....	<b>22</b>

## 4 Revision History

<b>Changes from Original (May 2015) to Revision A</b>	<b>Page</b>
• Changed the <i>Pin Configuration</i> images .....	<b>3</b>
• Changed CT (pF) To: CT (μF) in <a href="#">Equation 1</a> .....	<b>15</b>

## 5 Device Comparison Table

PART NO.	UVLO ON	UVLO OFF	MAXIMUM DUTY CYCLE
UC1842A	16 V	10 V	<100%
UC1843A	8.5 V	7.9 V	<100%
UC1844A	16 V	10 V	<50%
UC1845A	8.5 V	7.9 V	<50%

## 6 Pin Configuration and Functions

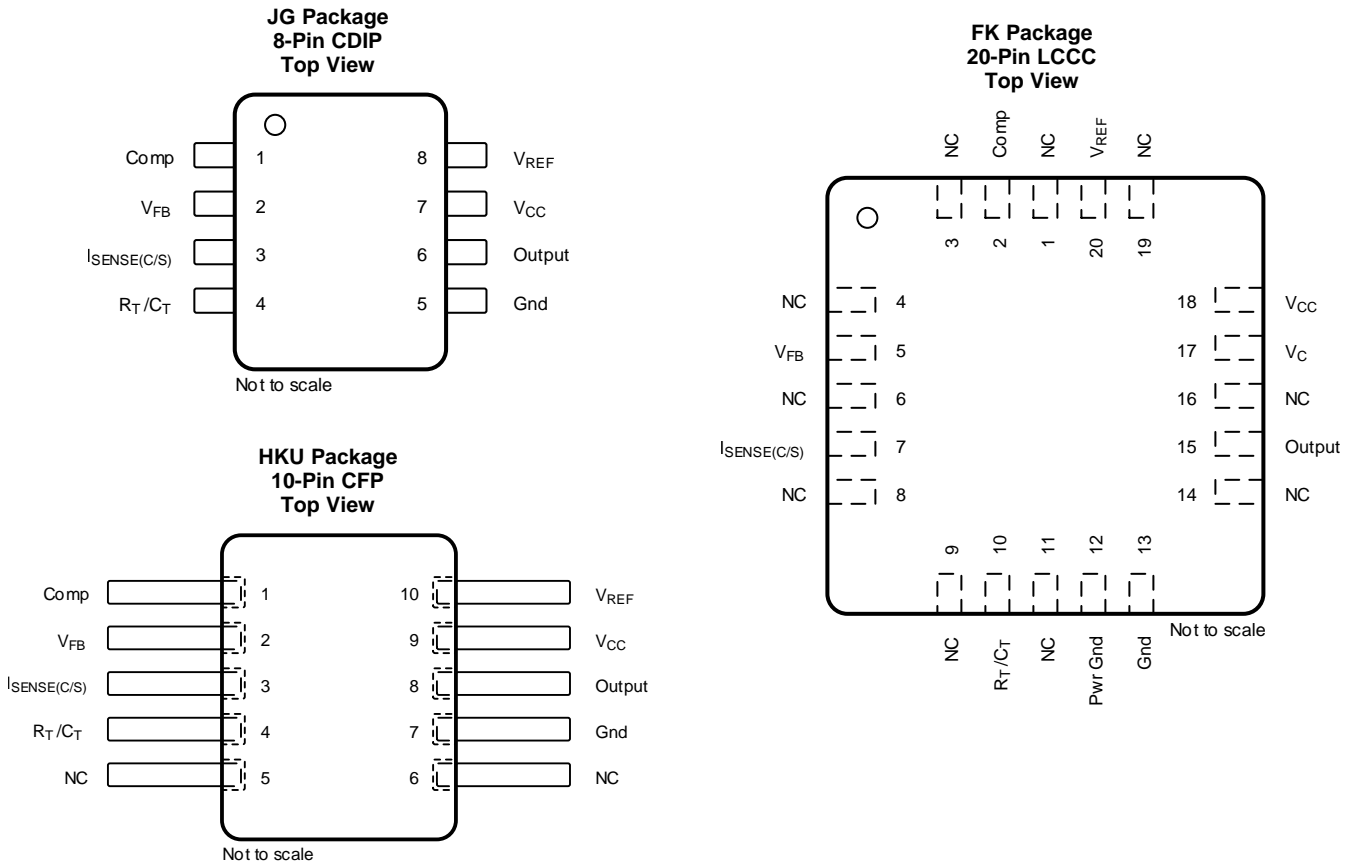

### Pin Functions

NAME	PIN			I/O	DESCRIPTION
	CDIP	LCCC	CFP		
Comp	1	2	1	I	Error amplifier output.
V <sub>FB</sub>	2	5	2	I	Voltage feedback input to error amplifier.
I <sub>SENSE(C/S)</sub>	3	7	3	I	Current sense comparator input pin.
R <sub>T</sub> /C <sub>T</sub>	4	10	4	I	RC time constant input to oscillator.
NC	—	1, 3, 4, 6, 8, 9, 11, 14, 16, 19	5, 6	—	No connect.
Pwr Gnd	—	12	—	—	Output section ground.
Gnd	5	13	7	—	Ground.
Output	6	15	8	O	Regulated output.
V <sub>C</sub>	—	17	—	—	Output section supply voltage.
V <sub>CC</sub>	7	18	9	—	Unregulated supply voltage.

**Pin Functions (continued)**

PIN				I/O	DESCRIPTION
NAME	CDIP	LCCC	CFP		
V <sub>REF</sub>	8	20	10	O	5-V internally generated reference.

## 7 Specifications

### 7.1 Absolute Maximum Ratings<sup>(1)(2)</sup>

over operating free-air temperature (unless otherwise noted)

		MIN	MAX	UNIT
V <sub>CC</sub>	Supply voltage, low-impedance source		30	V
V <sub>I</sub>	Input voltage (V <sub>FB</sub> , I <sub>SENSE</sub> )	-0.3	6.3	V
	Supply current	Self limiting		
I <sub>O</sub>	Output current		±1	A
	Error amplifier output sink current		10	mA
	Output energy (capacitive load)		5	μJ
P <sub>D</sub>	Power dissipation (T <sub>A</sub> = 25°C)		1	W
T <sub>J</sub>	Junction temperature		150	°C
T <sub>stg</sub>	Storage temperature	-65	150	°C

- Stresses beyond those listed under *Absolute Maximum Ratings* may cause permanent damage to the device. These are stress ratings only, and functional operation of the device at these or any other conditions beyond those indicated under *Recommended Operating Conditions* is not implied. Exposure to absolute-maximum-rated conditions for extended periods may affect device reliability.
- All voltages are with respect to ground. Currents are positive in, negative out of the specified terminal.

### 7.2 ESD Ratings

		VALUE	UNIT
V <sub>(ESD)</sub>	Electrostatic discharge Human-body model (HBM), per ANSI/ESDA/JEDEC JS-001 <sup>(1)</sup>	±4000	V

- JEDEC document JEP155 states that 500-V HBM allows safe manufacturing with a standard ESD control process.

### 7.3 Recommended Operating Conditions

 over operating free-air temperature range (T<sub>A</sub> = T<sub>J</sub> = -55°C to 125°C), unless otherwise noted

		MIN	MAX	UNIT
V <sub>CC</sub>	Supply voltage	12	25	V
	Sink/source output current (continuous or time average)	0	200	mA
	Reference load current	0	20	mA

### 7.4 Thermal Information

THERMAL METRIC <sup>(1)</sup>		UC1845A-SP			UNIT
		JG (CDIP)	FK (LCCC)	HKU (CFP)	
		8 PINS	20 PINS	10 PINS	
R <sub>θJA</sub>	Junction-to-ambient thermal resistance	103	—	51.9	°C/W
R <sub>θJC(bot)</sub>	Junction-to-case (bottom) thermal resistance	9.6	9.0	6.6	°C/W
R <sub>θJB</sub>	Junction-to-board thermal resistance	69.2	—	31.5	°C/W
ψ <sub>JT</sub>	Junction-to-top characterization parameter	13.9	—	5.42	°C/W
ψ <sub>JB</sub>	Junction-to-board characterization parameter	73	—	31	°C/W

- For more information about traditional and new thermal metrics, see the *Semiconductor and IC Package Thermal Metrics* application report.

## 7.5 Electrical Characteristics

 $V_{CC} = 15\text{ V}^{(1)}$ ,  $R_T = 10\text{ k}\Omega$ ,  $C_T = 3.3\text{ nF}$ ,  $T_A = T_J = -55^\circ\text{C}$  to  $125^\circ\text{C}$  (unless otherwise noted) <sup>(2)</sup>

PARAMETER	TEST CONDITIONS	MIN	TYP	MAX	UNIT	
<b>REFERENCE</b>						
Output voltage	$T_J = 25^\circ\text{C}$ , $I_O = 1\text{ mA}$ , $V_{CC} = 15\text{ V}$	5962-8670408VxA	4.95	5	5.06	V
		5962P8670411Vxx Pre-radiation	4.94	5	5.06	
		5962P8670411Vxx Post-radiation	4.85		5.06	
Line regulation	$V_{IN} = 12\text{ to }25\text{ V}$		6	20	mV	
Load regulation	$I_O = 1\text{ to }20\text{ mA}$		6	25	mV	
Temperature stability <sup>(3)(4)(5)</sup>			0.2	0.4	mV/ $^\circ\text{C}$	
Total output variation <sup>(3)</sup>	Over line, load, and temperature	4.9		5.1	V	
Output noise variation	$10\text{ Hz} \leq f \leq 10\text{ kHz}$ , $T_J = 25^\circ\text{C}$		50		$\mu\text{V}$	
Long-term stability <sup>(5)</sup>	1000 hours, $T_A = 125^\circ\text{C}^{(3)}$		5	25	mV	
Short-circuit output current		-30	-100	-180	mA	
<b>OSCILLATOR</b>						
Initial accuracy	$T_J = 25^\circ\text{C}^{(6)}$	47	52	57	kHz	
Voltage stability	$V_{CC} = 12\text{ to }25\text{ V}$		0.2%	1%		
Temperature stability	$T_J = -55^\circ\text{C}$ to $125^\circ\text{C}^{(3)}$		5%			
Amplitude	$V_{RT/CT}$ peak to peak <sup>(3)</sup>		1.7		V	
Discharge current	$V$ pin 4 = $2\text{ V}^{(7)}$	$T_J = 25^\circ\text{C}$	7.8	8.3	8.8	mA
		$T_J = \text{Full range}$	7.5		8.8	mA
<b>ERROR AMPLIFIER</b>						
Input voltage	$V_{Comp} = 2.5\text{ V}$	2.45	2.50	2.55	V	
Input bias current			-0.3	-1	$\mu\text{A}$	
Open-loop voltage gain	$V_O = 2\text{ to }4\text{ V}$	65	90		dB	
Unity-gain bandwidth	$T_J = 25^\circ\text{C}^{(3)}$	0.7	1		MHz	
PSRR	$V_{CC} = 12\text{ to }25\text{ V}$	60	70		dB	
Output sink current	$V_{FB} = 2.7\text{ V}$ , $V_{Comp} = 1.1\text{ V}$	2	6		mA	
Output source current	$V_{FB} = 2.3\text{ V}$ , $V_{Comp} = 5\text{ V}$	-0.5	-0.8		mA	
High-level output voltage	$V_{FB} = 2.3\text{ V}$ , $R_L = 15\text{ k}\Omega$ to ground	5	6		V	
Low-level output voltage	$V_{FB} = 2.7\text{ V}$ , $R_L = 15\text{ k}\Omega$ to $V_{REF}$		0.7	1.1	V	
<b>CURRENT SENSE</b>						
Gain <sup>(8)(9)</sup>		2.85	3	3.15	V/V	
Maximum input signal	$V_{Comp} = 5\text{ V}^{(8)}$	0.9	1	1.1	V	
PSRR	$V_{CC} = 12\text{ to }25\text{ V}^{(8)}$		70		dB	
Input bias current			-2	-10	$\mu\text{A}$	
Delay to output	$V_{ISENSE} = 0\text{ to }2\text{ V}^{(3)}$		150	300	ns	

(1) Adjust  $V_{CC}$  above the start threshold before setting at 15 V.

(2) See [Mechanical, Packaging, and Orderable Information](#) for radiation improved devices.

(3) Parameters ensured by design and/or characterization, if not production tested.

(4) Temperature stability, sometimes referred to as average temperature coefficient, is described by the equation:

Temperature Stability =  $(V_{REF}(\text{max}) - V_{REF}(\text{min})) / (T_J(\text{max}) - T_J(\text{min}))$ .  $V_{REF}(\text{max})$  and  $V_{REF}(\text{min})$  are the maximum and minimum reference voltage measured over the appropriate temperature range. Note that the extremes in voltage do not necessarily occur at the extremes in temperature.

(5) Parameter applies only for 5962-8670408VxA.

(6) Output frequency is one-half oscillator frequency for UC1845A.

(7) This parameter is measured with  $R_T = 10\text{ k}\Omega$  to  $V_{REF}$ . This contributes approximately 300  $\mu\text{A}$  of current to the measurement. The total current flowing into the  $R_T$  or  $C_T$  pin will be approximately 300  $\mu\text{A}$  higher than the measured value.

(8) Parameter measured at trip point of latch with  $V_{FB} = 0\text{ V}$ .

(9) Gain defined as:  $G = \Delta V_{Comp} / \Delta V_{ISENSE}$ ;  $V_{ISENSE} = 0$  to  $0.8\text{ V}$ .

### Electrical Characteristics (continued)

$V_{CC} = 15\text{ V}^{(1)}$ ,  $R_T = 10\text{ k}\Omega$ ,  $C_T = 3.3\text{ nF}$ ,  $T_A = T_J = -55^\circ\text{C}$  to  $125^\circ\text{C}$  (unless otherwise noted) <sup>(2)</sup>

PARAMETER	TEST CONDITIONS	MIN	TYP	MAX	UNIT
<b>OUTPUT</b>					
Output low-level voltage	$I_{SINK} = 20\text{ mA}$		0.1	0.4	V
	$I_{SINK} = 200\text{ mA}$		1.5	2.2	
Output high-level voltage	$I_{SOURCE} = -20\text{ mA}$	13	13.5		V
	$I_{SOURCE} = -200\text{ mA}$	12	13.5		
Rise time	$C_L = 1\text{ nF}$ , $T_J = 25^\circ\text{C}^{(3)}$		50	150	ns
Fall time	$C_L = 1\text{ nF}$ , $T_J = 25^\circ\text{C}^{(3)}$		50	150	ns
UVLO saturation	$V_{CC} = 5\text{ V}$ , $I_{SINK} = 10\text{ mA}$		0.7	1.2	V
<b>UNDervOLTAGE LOCKOUT</b>					
Start threshold		7.8	8.4	9	V
Minimum operation voltage after turnon		7	7.6	8.2	V
<b>PWM</b>					
Maximum duty cycle		47%	48%	50%	
Minimum duty cycle				0%	
<b>TOTAL STANDBY CURRENT</b>					
Start-up current			0.3	0.5	mA
Operating supply current	$V_{FB} = V_{ISENSE} = 0\text{ V}$		11	17	mA
$V_{CC}$ Zener voltage	$I_{CC} = 25\text{ mA}$	30	34		V

### 7.6 Typical Characteristics

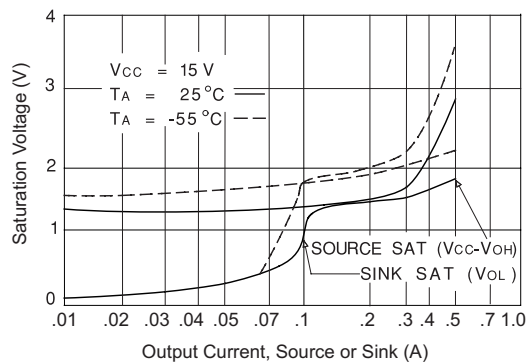

Figure 1. Output Saturation Characteristics

## 8 Detailed Description

### 8.1 Overview

The UC1845A-SP control IC is a pin-for-pin compatible improved version of the UC184x family. Providing the necessary characteristics to control current-mode switched-mode power supplies, this device has improved features. Start-up current is specified to be less than 0.5 mA and oscillator discharge is trimmed to 8.3 mA. During UVLO, the output stage can sink at least 10 mA at less than 1.2 V for  $V_{CC}$  over 5 V.

### 8.2 Functional Block Diagram

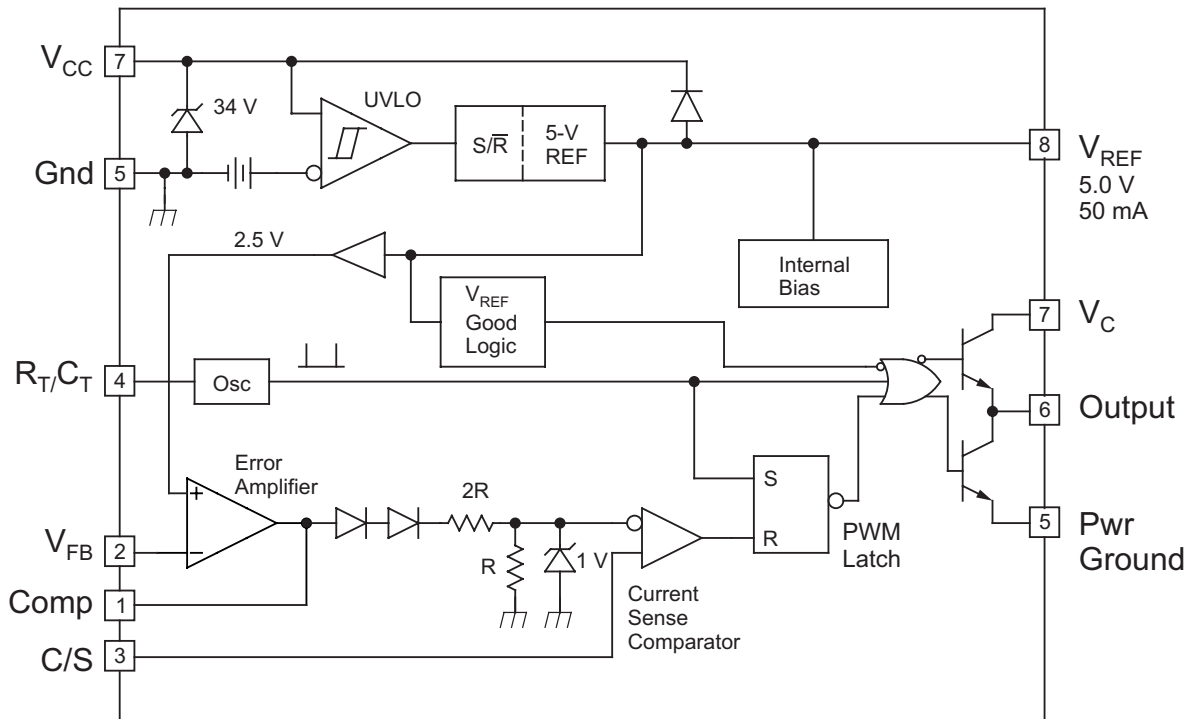

Copyright © 2016, Texas Instruments Incorporated

### 8.3 Feature Description

UC1845A-SP is a current mode controller, used to support various topologies such as forward, flyback, buck, boost and using an external interface circuit will also support half-bridge, full-bridge, and push-pull configurations.

Figure 2 shows the two-loop current-mode control system in a typical buck regulator application. A clock signal initiates power pulses at a fixed frequency. The termination of each pulse occurs when an analog of the inductor current reaches a threshold established by the error signal. In this way, the error signal actually controls peak inductor current. This contrasts with conventional schemes in which the error signal directly controls pulse width without regard to inductor current.

Several performance advantages result from the use of current-mode control. First, an input voltage feed-forward characteristic is achieved; that is, the control circuit instantaneously corrects for input voltage variations without using up any of the error amplifier's dynamic range. Therefore, line regulation is excellent and the error amplifier can be dedicated to correcting for load variations exclusively.

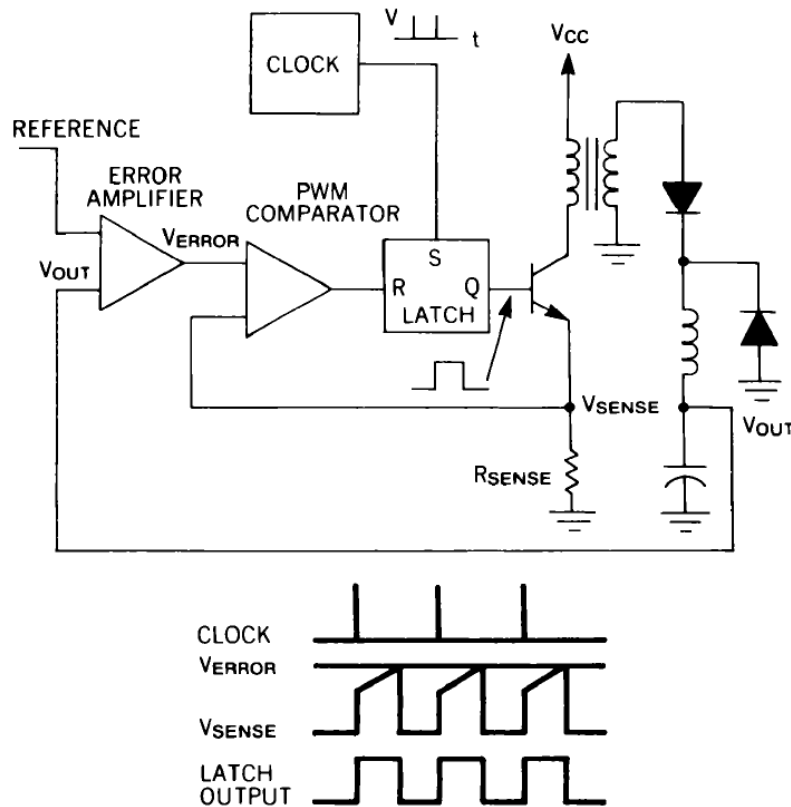
**Feature Description (continued)**

0019-1

**Figure 2. Two-Loop Current-Mode Control System**

For converters in which inductor current is continuous, controlling peak current is nearly equivalent to controlling average current. Therefore, when such converters employ current-mode control, the inductor can be treated as an error-voltage-controlled-current-source for the purposes of small-signal analysis (see [Figure 3](#)). The two-pole control-to-output frequency response of these converters is reduced to a single-pole (filter capacitor in parallel with load) response. One result is that the error amplifier compensation can be designed to yield a stable closed-loop converter response with greater gain bandwidth than would be possible with pulse-width control, giving the supply improved small-signal dynamic response to changing loads. A second result is that the error amplifier compensation circuit becomes simpler, as shown in [Figure 4](#).

Capacitor  $C_i$  and resistor  $R_i$ , in [Figure 4\(A\)](#), add a low-frequency zero, which cancels one of the two control-to-output poles of non-current-mode converters. For large signal load changes, in which converter response is limited by inductor slew rate, the error amplifier saturates while the inductor is catching up with the load. During this time,  $C_i$  charges to an abnormal level. When the inductor current reaches its required level, the voltage on  $C_i$  causes a corresponding error in supply output voltage. The recovery time is  $R_{iz}C_i$ , which may be long. However, the compensation network of [Figure 4\(B\)](#) can be used where current-mode control has eliminated the inductor pole. Large-signal dynamic response is then greatly improved due to the absence of  $C_i$ .

Current limiting is greatly simplified with current-mode control. Pulse-by-pulse limiting is, of course, inherent in the control scheme. Furthermore, an upper limit on the peak current can be established by simply clamping the error voltage. Accurate current limiting allows optimization of magnetic and power semiconductor elements while ensuring reliable supply operation.

Finally, current-mode controlled power stages can be operated in parallel with equal current sharing. This opens the possibility of a modular approach to power supply design.



Feature Description (continued)

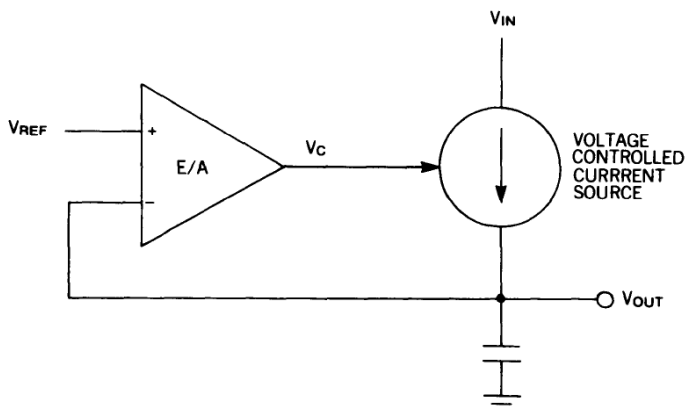

0019-2

Figure 3. Inductor Looks Like a Current Source to Small Signals

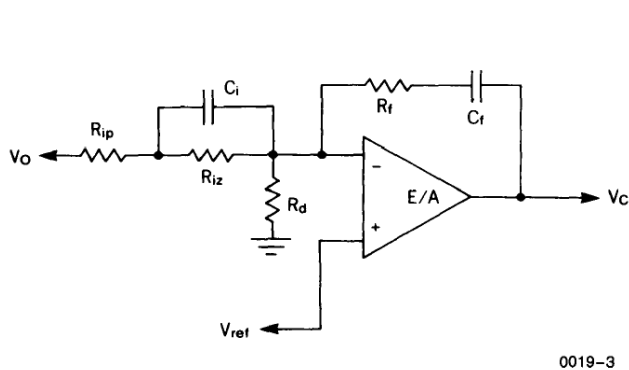

0019-3

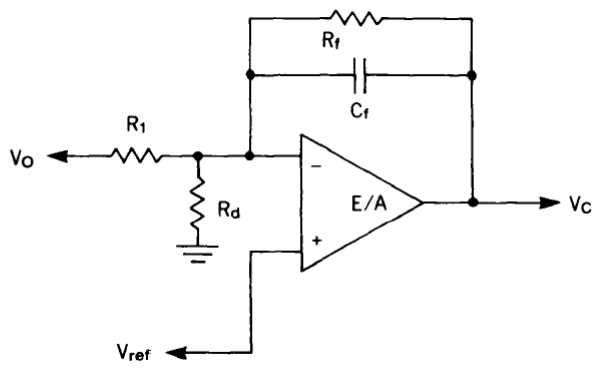

0019-4

A. Direct duty cycle control

B. Current mode control

Figure 4. Required Error Amplifier Compensation for Continuous Inductor Current Designs

8.3.1 UVLO

The UVLO circuit ensures that  $V_{CC}$  is adequate to make the UC1845A-SP fully operational before enabling the output stage. Figure 5 shows that the UVLO turnon and turnoff thresholds are fixed internally at 8.5 V and 7.9 V, respectively. The 0.6-V hysteresis prevents  $V_{CC}$  oscillations during power sequencing.

Figure 6 shows supply current requirements. Start-up current is < 1 mA for efficient bootstrapping from the rectified input of an off-line converter, as shown in Figure 7. During normal circuit operation,  $V_{CC}$  is developed from auxiliary winding,  $WAux$ , with  $D_1$  and  $C_{IN}$ . However, at start-up,  $C_{IN}$  must be charged to 16 V through  $R_{IN}$ . With a start-up current of 1 mA,  $R_{IN}$  can be as large as 100 k $\Omega$  and still charge  $C_{IN}$  when  $V_{AC} = 90$ -V RMS (low line). Power dissipation in  $R_{IN}$  would then be less than 350 mW even under high line ( $V_{AC} = 130$ -V RMS) conditions.

During UVLO, the output driver is in a low state. While it does not exhibit the same saturation characteristics as normal operation, it can easily sink 1 mA, enough to ensure the MOSFET is held off.

Feature Description (continued)

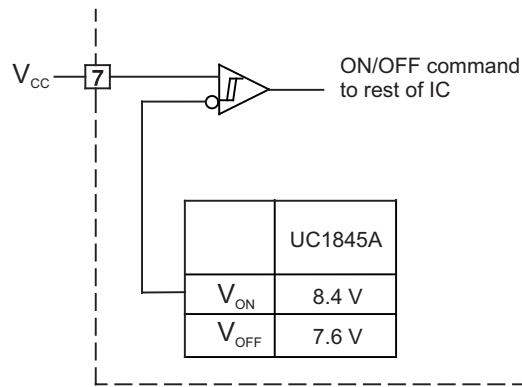
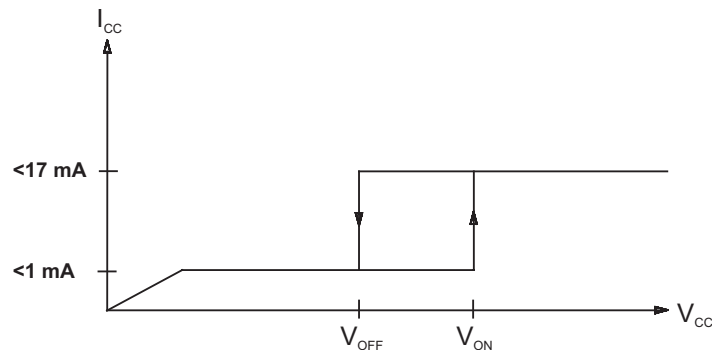
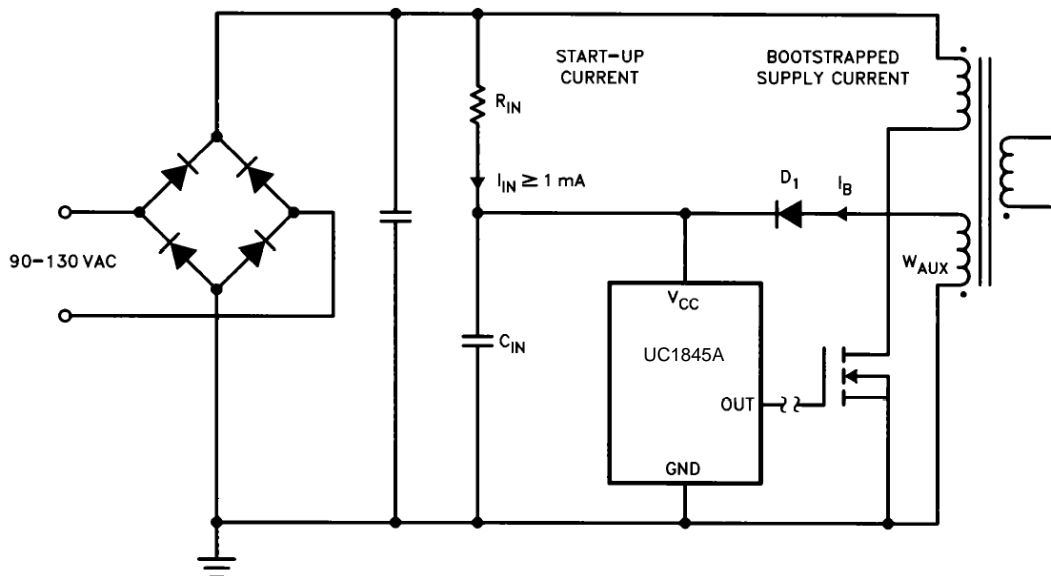

Figure 5. UVLO Turnon TurnOff Threshold



During UVLO, the output driver is biased to sink minor amounts of current.

Figure 6. Supply Current Requirements



0019-8

Figure 7. Providing Power to the UC1845A-SP

## Feature Description (continued)

### 8.3.2 Reference

As highlighted in the [Functional Block Diagram](#), UC1845A-SP incorporates a 5-V internal reference regulator with  $\pm 2\%$  set point variation over temperature.

### 8.3.3 Totem-Pole Output

The UC1845A-SP PWM has a single totem-pole output which can be operated to  $\pm 1$ -A peak for driving MOSFET gates, and a +200 mA average current for bipolar power U-100A transistors. Cross conduction between the output transistors is minimal, the average added power with  $V_{IN} = 30$  V is only 80 mW at 200 kHz.

Limiting the peak current through the IC is accomplished by placing a resistor between the totem-pole output and the gate of the MOSFET. The value is determined by dividing the totem-pole collector voltage  $V_C$  by the peak current rating of the IC's totem-pole. Without this resistor, the peak current is limited only by the  $dV/dT$  rate of the totem-pole switching and the FET gate capacitance.

The use of a Schottky diode from the PWM output to ground prevents the output voltage from going excessively below ground, causing instabilities within the IC. To be effective, the diode selected should have a forward drop of less than 0.3 V at 200 mA. Most 1- to 3-A Schottky diodes exhibit these traits above room temperature. Placing the diode as physically close to the PWM as possible enhances circuit performance. Implementation of the complete drive scheme is shown in [Figure 8](#) through [Figure 10](#). Transformer-driven circuits also require the use of the Schottky diodes to prevent a similar set of circumstances from occurring on the PWM output. The ringing below ground is greatly enhanced by the transformer leakage inductance and parasitic capacitance, in addition to the magnetizing inductance and FET gate capacitance. Circuit implementation is similar to the previous example.

[Figure 8](#) through [Figure 10](#) show suggested circuits for driving MOSFETs and bipolar transistors with the UC1845A-SP output. The simple circuit of [Figure 8](#) can be used when the control IC is not electrically isolated from the MOSFET turnon and turnoff to  $\pm 1$  A. It also provides damping for a parasitic tank circuit formed by the FET input capacitance and series wiring inductance. Schottky diode,  $D_1$ , prevents the output of the IC from going far below ground during turnoff.

[Figure 9](#) shows an isolated MOSFET drive circuit which is appropriate when the drive signal must be level shifted or transmitted across an isolation boundary. Bipolar transistors can be driven efficiently with the circuit of [Figure 10](#). Resistors  $R_1$  and  $R_2$  fix the on-state base current while capacitor  $C_1$  provides a negative base current pulse to remove stored charge at turnoff.

Because the UC1845A-SP series has only a single output, an interface circuit is needed to control push-pull, half-bridge, or full-bridge topologies. The UC1706 dual output driver with internal toggle flip-flop performs this function. [Typical Application](#) shows a typical application for these two ICs. Increased drive capability for driving numerous FETs in parallel, or other loads can be accomplished using one of the UC1705/6/7 driver ICs.

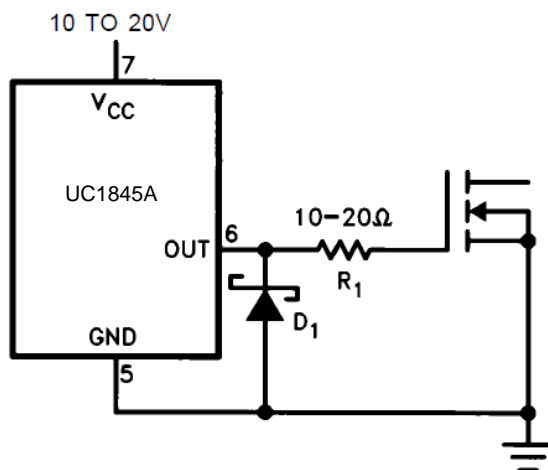

0019-19

Figure 8. Direct MOSFET Drive

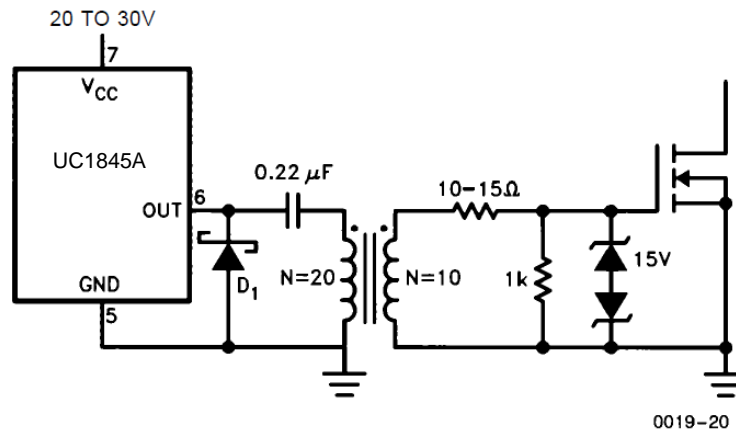
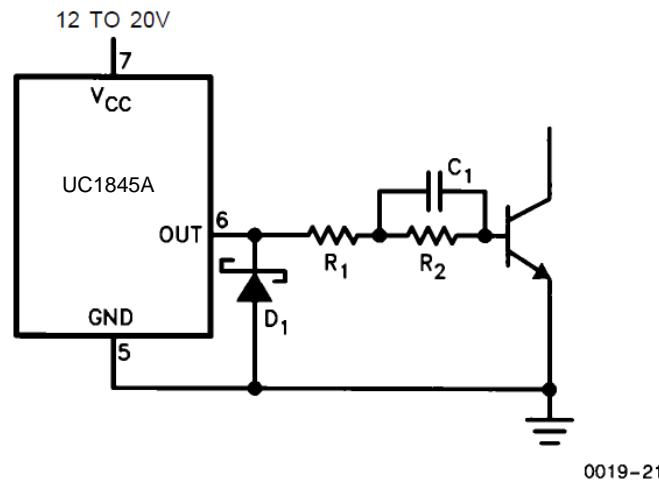
**Feature Description (continued)**

**Figure 9. Isolated MOSFET Drive**

**Figure 10. Bipolar Drive With Negative turnoff Bias**
**8.4 Device Functional Modes**

The UC1845A-SP uses fixed frequency, peak current mode control. An internal oscillator initiates the turn on of the driver to high-side power switch. The external power switch current is sensed through an external resistor and is compared via internal comparator. The voltage generated at the COMP pin is stepped down via internal resistors (as shown in the functional block diagram). When the sensed current reaches the stepped down COMP voltage, the high-side power switch is turned off.

## 9 Application and Implementation

### NOTE

Information in the following applications sections is not part of the TI component specification, and TI does not warrant its accuracy or completeness. TI's customers are responsible for determining suitability of components for their purposes. Customers should validate and test their design implementation to confirm system functionality.

### 9.1 Application Information

UC1845A-SP can be used as a controller to design various topologies such as buck, boost, flyback, and forward. Using an external interphase circuit can also support push-pull, half-bridge and full-bridge topologies.

### 9.2 Typical Application

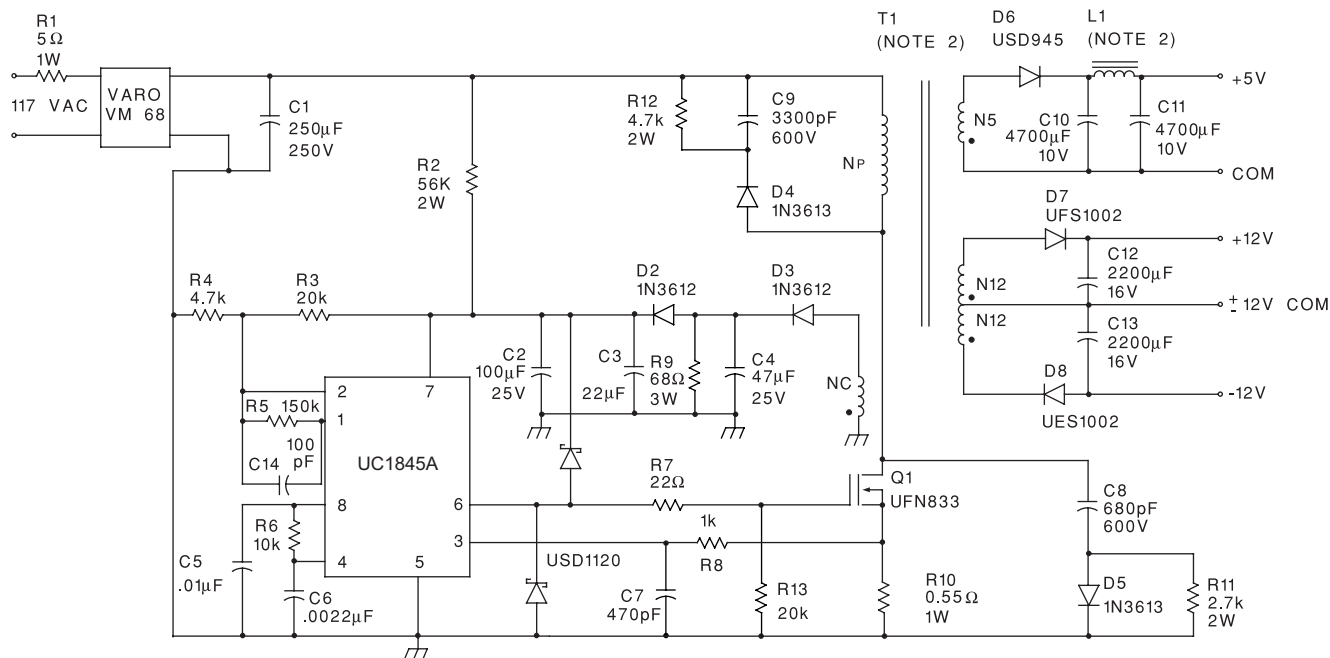

Figure 11. Typical Application Schematic

#### 9.2.1 Design Requirements

See [Table 1](#) for parameter values.

Table 1. Design Parameters<sup>(1)</sup>

DESIGN PARAMETER	VALUE
Input voltage	95 VAC to 130 VAC
Line isolation	3750 V
Switching frequency	40 kHz
Efficiency (full load)	70%
Output voltage (A)	+5 V, ±5%; 1-A to 4-A load; Ripple voltage: 50-mV P-P max
Output voltage (B)	+12 V, ±3%; 0.1-A to 0.3-A load; Ripple voltage: 100-mV P-P max
Output voltage (C)	-12 V, ±3%; 0.1-A to 0.3-A load; Ripple voltage: 100-mV P-P max

(1) See [Figure 11](#) for reference.

## 9.2.2 Detailed Design Procedure

See [Table 2](#) for component values.

**Table 2. Components<sup>(1)</sup>**

COMPONENT	VALUE
R1	5 $\Omega$ , 1 W
R2	56 k $\Omega$ , 2 W
R3	20 k $\Omega$
R4	4.7 k $\Omega$
R5	150 k $\Omega$
R6	10 k $\Omega$
R7	22 $\Omega$
R8	1 k $\Omega$
R9	68 $\Omega$
R10	0.55 $\Omega$ , 1 W
R11	2.7 k $\Omega$ , 2 W
R12	4.7 k $\Omega$ , 2 W
R13	20 k $\Omega$
C1	250 $\mu$ F, 250 V
C2	100 $\mu$ F, 25 V
C3	22 $\mu$ F
C4	47 $\mu$ F, 25 V
C5	0.1 $\mu$ F
C6	0.0022 $\mu$ F
C7	470 pF
C8	680 pF, 600 V
C9	3300 pF, 600 V
C10	4700 $\mu$ F, 10 V
C11	4700 $\mu$ F, 10 V
C12	2200 $\mu$ F, 10 V
C13	2200 $\mu$ F, 10 V
C14	100 pF
D2	1N3612
D3	1N3612
D4	1N3613
D5	1N3613
D6	USD945
D7	UFS1002
D8	UES1002
Q1	UFN833

(1) See [Figure 11](#) for reference.

### 9.2.2.1 Oscillator

The UC1845A-SP oscillator is programmed as shown in [Figure 13](#). Timing capacitor  $C_T$  is charged from  $V_{REF}$  (5 V) through the timing resistor  $R_T$ , and discharged by an internal current source. The first step in selecting the oscillator components is to determine the required circuit dead time. Once obtained, [Figure 14](#) is used to pinpoint the nearest standard value of  $C_T$  for a given dead time. Next, the appropriate  $R_T$  value is interpolated using the parameters for  $C_T$  and oscillator frequency. [Figure 15](#) shows the  $R_T/C_T$  combinations versus oscillator frequency. The timing resistor can be calculated from the following formula.

$$f_{osc} \text{ (kHz)} = \frac{1.72}{R_T \text{ (k}\Omega) \times C_T \text{ (\mu F)}} \quad (1)$$

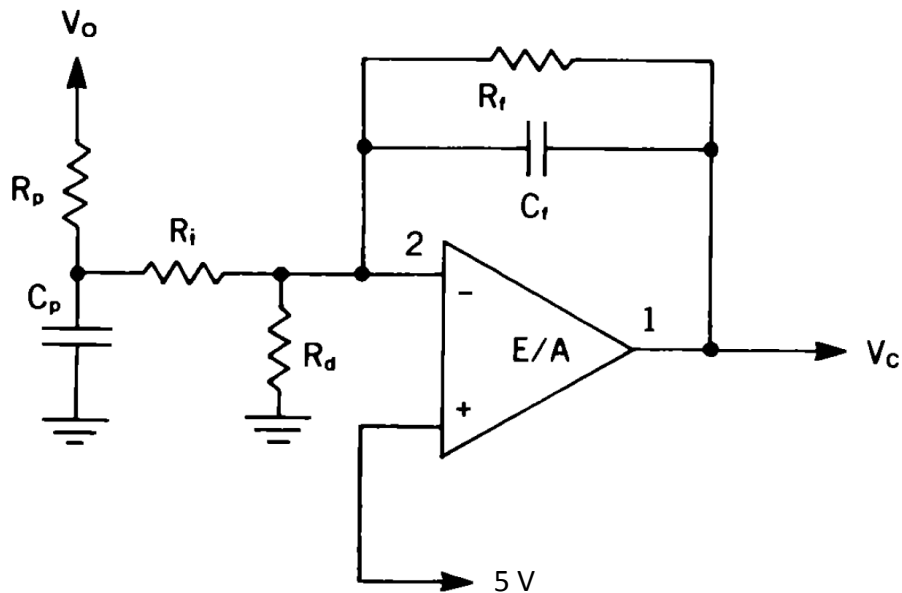

Figure 12. E/A Compensation Circuit for Continuous Boost and Flyback Topologies

The UC1845A-SP has an internal divide-by-two flip-flop driven by the oscillator for a 50% maximum duty cycle. Therefore, their oscillators must be set to run at twice the desired power supply switching frequency.

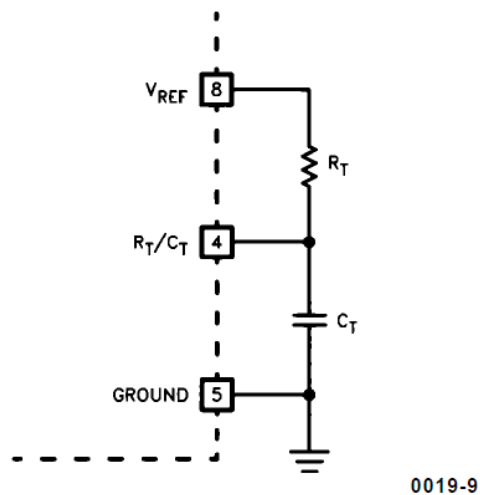
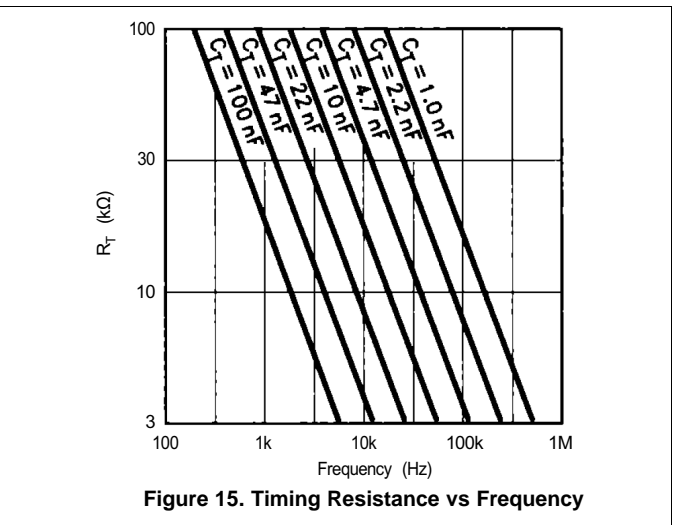
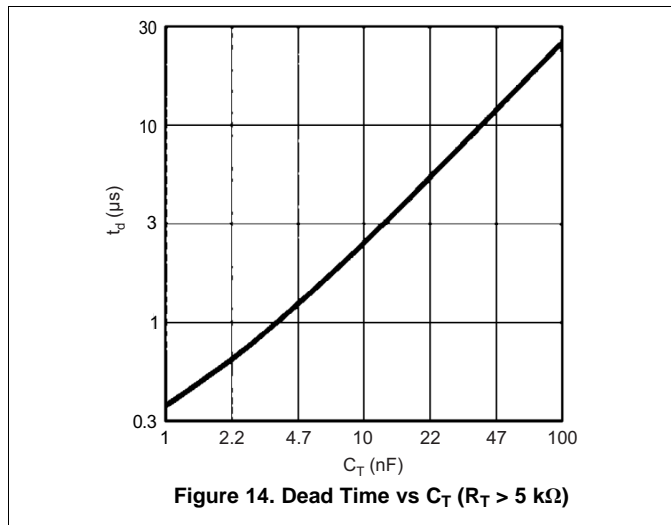

Figure 13. Oscillator Programming



### 9.2.2.2 Current Sensing and Limiting

The UC1845A-SP current sense input is configured as shown in [Figure 16](#). Current-to-voltage conversion is done externally with ground-referenced resistor  $R_S$ . Under normal operation, the peak voltage across  $R_S$  is controlled by the E/A according to the following relation:

$$I_p = \frac{V_C - 1.4 \text{ V}}{3 R_S}$$

where

- $V_C$  = Control voltage = E/A output voltage (2)

$R_S$  can be connected to the power circuit directly or through a current transformer, as [Figure 16](#) shows. While a direct connection is simpler, a transformer can reduce power dissipation in  $R_S$ , reduce errors caused by the base current, and provide level shifting to eliminate the restraint of ground-referenced sensing. The relation between  $V_C$  and peak current in the power stage is given by:

$$i_{(pk)} = N \left( \frac{V_{R_S(pk)}}{R_S} \right) = \frac{N}{3 R_S} (V_C - 1.4 \text{ V})$$

where

- $N$  = Current sense transformer turns ratio = 1 when transformer not used. (3)

For purposes of small-signal analysis, the control-to-sensed-current gain is:

$$\frac{i_{(pk)}}{V_C} = \frac{N}{3 R_S} \tag{4}$$

When sensing current in series with the power transistor, as shown in [Figure 16](#), the current waveform often has a large spike at its leading edge. This spike is due to rectifier recovery and/or inter-winding capacitance in the power transformer. If unattenuated, this transient can prematurely terminate the output pulse. As shown, a simple RC filter is usually adequate to suppress this spike. The RC time constant should be approximately equal to the current spike duration (usually a few hundred nanoseconds).

The inverting input to the UC1845A-SP current-sense comparator is internally clamped to 1 V ([Figure 16](#)). Current limiting occurs if the voltage at pin 3 reaches this threshold value, that is, the current limit is defined by:

$$i_{\max} = \frac{N \times 1 \text{ V}}{R_S} \tag{5}$$



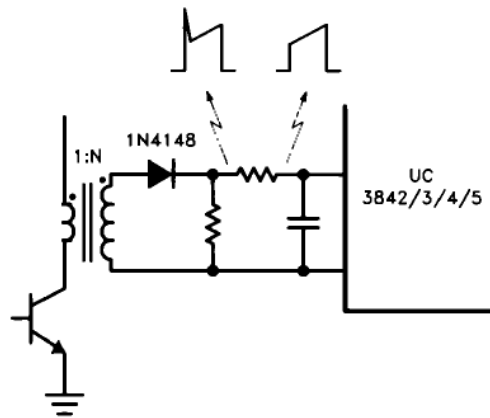

0019-13

Figure 16. Transformer-Coupled Current Sensing

### 9.2.2.3 Error Amplifier

The error amplifier (E/A) configuration is shown in Figure 17. The non-inverting input is not brought out to a pin, but is internally biased to  $5\text{ V} \pm 2\%$ . The E/A output is available at pin 1 for external compensation, allowing the user to control the converter's closed-loop frequency response.

Figure 18 shows an E/A compensation circuit suitable for stabilizing any current-mode controlled topology except for flyback and boost converters operating with inductor current. The feedback components add a pole to the loop transfer function at  $f_p = \frac{1}{2} \pi R_F$ .  $R_F$  and  $C_F$  are chosen so that this pole cancels the zero of the output filter capacitor ESR in the power circuit.  $R_1$  and  $R_F$  fix the low-frequency gain. They are chosen to provide as much gain as possible while still allowing the pole formed by the output filter capacitor and load to roll off the loop gain to unity (0 dB) at  $f \approx f_{\text{SWITCHING}} / 4$ . This technique ensures converter stability while providing good dynamic response.

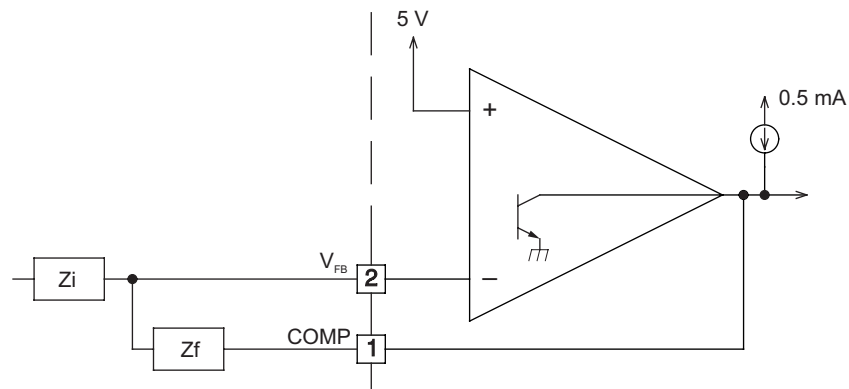
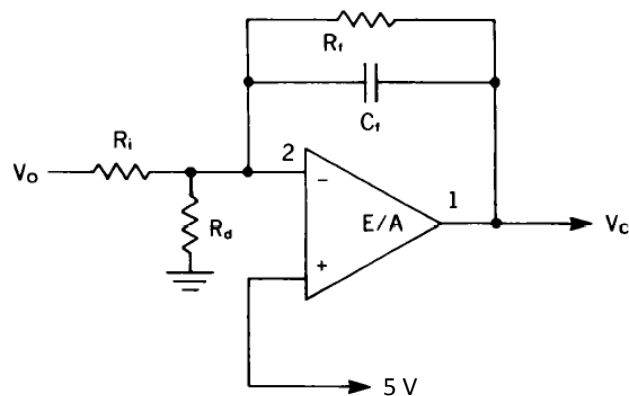

Figure 17. E/A Configuration



0019–15

**Figure 18. Compensation**

The E/A output sources 0.5 mA and sinks 2 mA. A lower limit for  $R_F$  is given by:

$$R_{F(MIN)} \approx \frac{V_{EA\ OUT(MAX)} - 2.5\ V}{0.5\ mA} = \frac{6\ V - 2.5\ V}{0.5\ mA} = 7\ k\Omega \quad (6)$$

E/A input bias current (2- $\mu$ A max) flows through  $R_i$ , resulting in a DC error in output voltage ( $V_O$ ) given by:

$$\Delta V_{O(MAX)} = (2\ \mu A) R_i \quad (7)$$

Therefore, the designer should keep the value of  $R_i$ , as low as possible.

Figure 19 shows the open-loop frequency response of the UC1845A-SP E/A. The gain represents an upper limit on the gain of the compensated E/A. Phase lag increases rapidly as frequency exceeds 1 MHz due to second-order poles at about 10 MHz and above.

Continuous-inductor-current boost and flyback converters each have a right-half-plane zero in their transfer function. An additional compensation pole is needed to roll off loop gain at a frequency less than that of the RHP zero.  $R_P$  and  $C_P$  in the circuit of Figure 12 provide this pole.

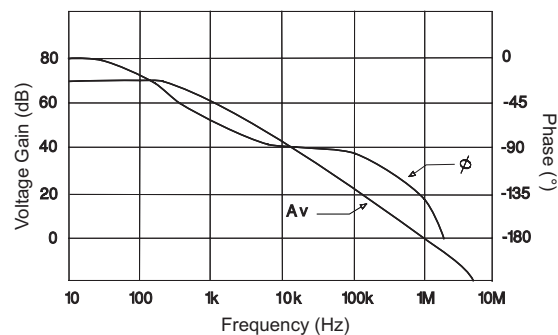
**Figure 19. Error Amplifier Open-Loop Frequency Response**

9.2.3 Application Curves

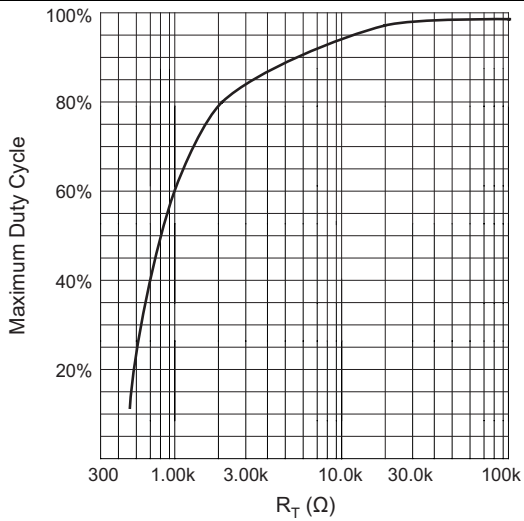

Figure 20. Oscillator Frequency vs Timing Resistance

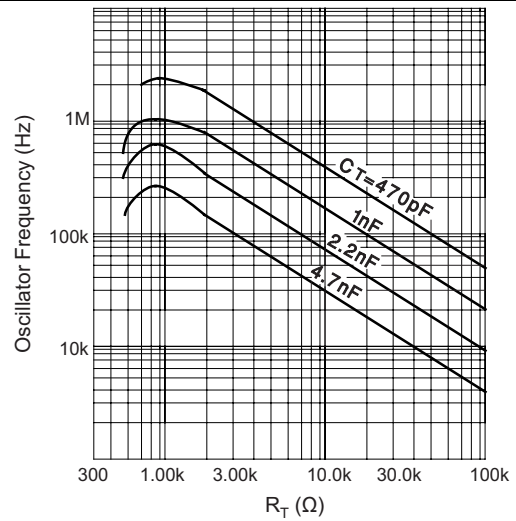
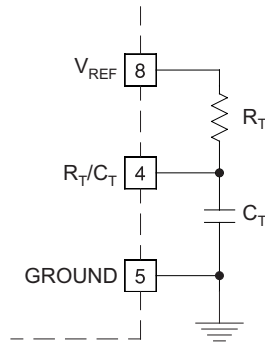

Figure 21. Maximum Duty Cycle vs Timing Resistor



For  $R_T > 5k$   $f \approx 1.72 / (R_T C_T)$

Figure 22. Oscillation Schematic

## 10 Power Supply Recommendations

The devices are designed to operate from an input voltage supply range between 8 V and 40 V. This input supply should be well regulated. If the input supply is located more than a few inches from the UC1845A-SP converter, additional bulk capacitance may be required in addition to the ceramic bypass capacitors. A tantalum capacitor with a value of 47  $\mu\text{F}$  is a typical choice; however, this may vary depending upon the output power being delivered.

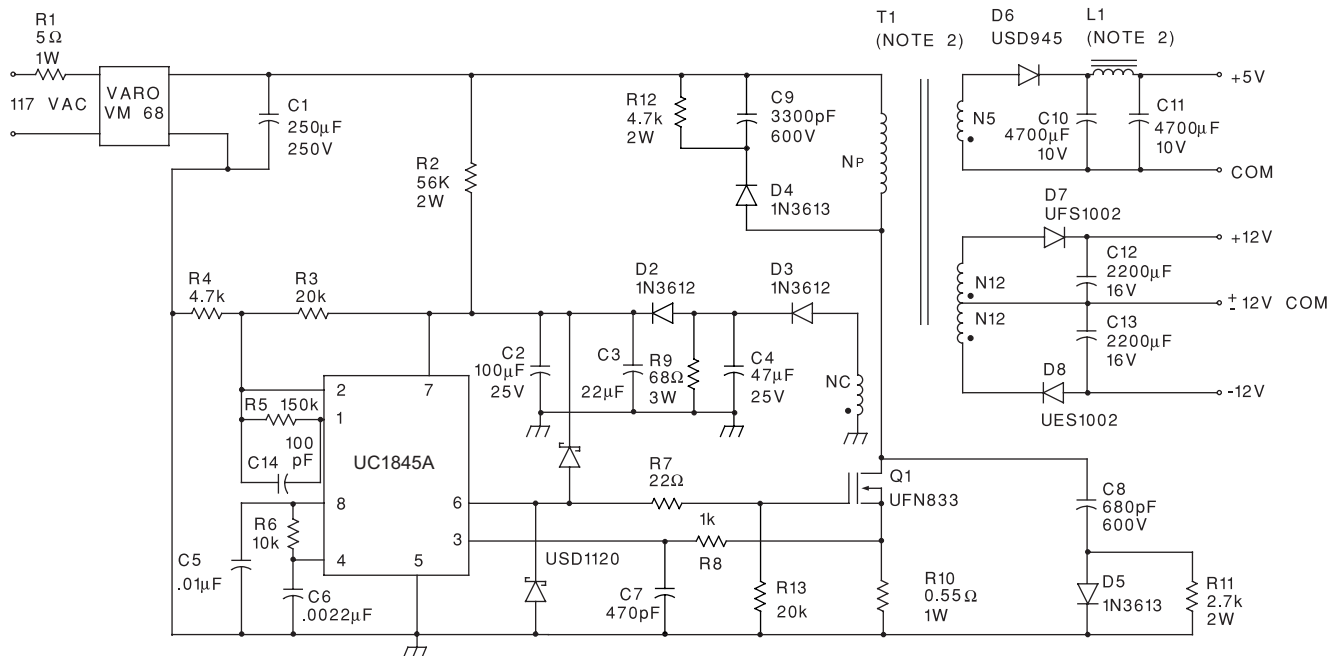

Power supply specifications:

1. Input voltage: 95 VAC to 130 VAC (50 Hz/60 Hz)
2. Line isolation: 3750 V
3. Switching frequency: 40 kHz
4. Efficiency full load: 70%
5. Output voltage:
  - a. +5 V,  $\pm 5\%$ ; 1- to 4-A load, ripple voltage: 50 mVP-P max
  - b. +12 V,  $\pm 3\%$ ; 0.1- to 0.3-A load, ripple voltage: 100 mVP-P max
  - c. -12 V,  $\pm 3\%$ ; 0.1- to 0.3-A load, ripple voltage: 100 mVP-P max

Figure 23. Offline Flyback Regulator

## 11 Layout

### 11.1 Layout Guidelines

Always try to use a low-EMI inductor with a ferrite-type closed core. Some examples would be toroid and encased E core inductors. Open core can be used if they have low-EMI characteristics and are located a farther away from the low-power traces and components. Make the poles perpendicular to the PCB as well if using an open core. Stick cores usually emit the most unwanted noise.

#### 11.1.1 Feedback Traces

Try to run the feedback trace as far as possible from the inductor and noisy power traces. The designer should also make the feedback trace as direct as possible and somewhat thick. These two guidelines sometimes involve a trade-off, but keeping the trace away from inductor EMI and other noise sources is the more critical guideline. Run the feedback trace on the side of the PCB opposite of the inductor with a ground plane separating the two.

## Layout Guidelines (continued)

### 11.1.2 Input/Output Capacitors

When using a low-value ceramic input filter capacitor, locate it as close as possible to the VIN pin of the IC. This eliminates as much trace inductance effects as possible and gives the internal IC rail a cleaner voltage supply. Some designs require the use of a feed-forward capacitor connected from the output to the feedback pin as well, usually for stability reasons. In this case, it should also be positioned as close as possible to the IC. Using surface mount capacitors also reduces lead length and lessens the chance of noise coupling into the effective antenna created by through-hole components.

### 11.1.3 Compensation Components

External compensation components for stability should also be placed close to the IC. TI recommends to also use surface mount components for the same reasons discussed for the filter capacitors. These should not be located very close to the inductor either.

### 11.1.4 Traces and Ground Planes

Make all of the power (high-current) traces as short, direct, and thick as possible. It is good practice on a standard PCB to make the traces an absolute minimum of 15 mils (0.381 mm) per ampere. The inductor, output capacitors, and output diode should be as close as possible to each other. This helps reduce the EMI radiated by the power traces due to the high-switching currents through them. This also reduces lead inductance and resistance, which in turn reduces noise spikes, ringing, and resistive losses that produce voltage errors. The grounds of the IC, input capacitors, output capacitors, and output diode (if applicable) should be connected close together directly to a ground plane. It would also be a good idea to have a ground plane on both sides of the PCB. This reduces noise by reducing ground loop errors and absorbing more of the EMI radiated by the inductor.

For multi-layer boards with more than two layers, a ground plane can be used to separate the power plane (where the power traces and components are) and the signal plane (where the feedback and compensation and components are) for improved performance. On multi-layer boards, vias are required to connect traces and different planes. It is a good practice to use one standard via per 200 mA of current if the trace needs to conduct a significant amount of current from one plane to the other. Arrange the components so that the switching current loops curl in the same direction. Due to the way switching regulators operate, there are two power states: one state when the switch is on and one when the switch is off. During each state there is a current loop made by the power components that are currently conducting. Place the power components so that during each of the two states the current loop is conducting in the same direction. This prevents magnetic field reversal caused by the traces between the two half-cycles and reduces radiated EMI.

## 11.2 Layout Example

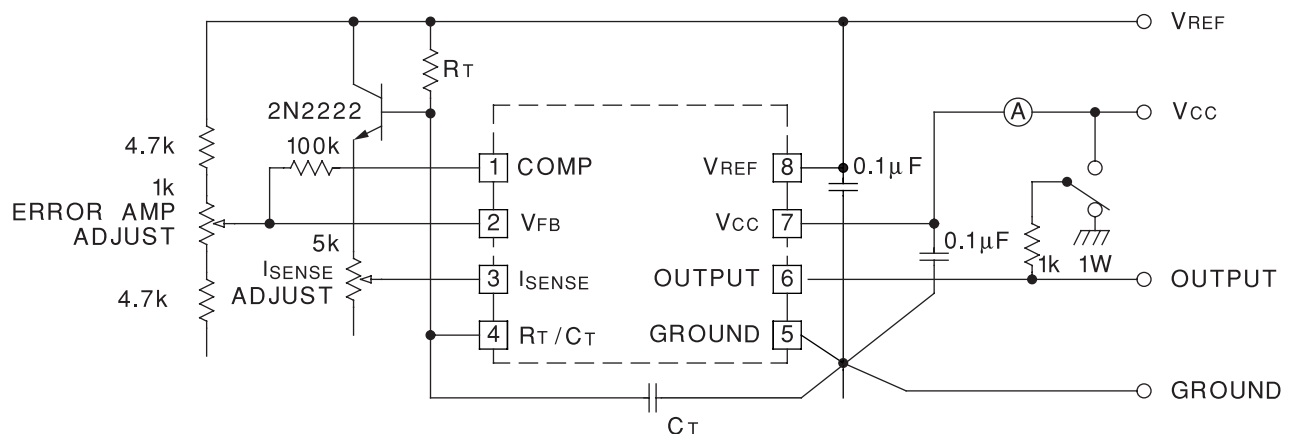

High peak currents associated with capacitive loads necessitate careful grounding techniques. Timing and bypass capacitors should be connected close to pin 5 in a single point ground. The transistor and 5k potentiometer are used to sample the oscillator waveform and apply an adjustable ramp to pin 3.

**Figure 24. Open-Loop Laboratory Test Fixture**

## 12 Device and Documentation Support

### 12.1 Receiving Notification of Documentation Updates

To receive notification of documentation updates, navigate to the device product folder on ti.com. In the upper right corner, click on *Alert me* to register and receive a weekly digest of any product information that has changed. For change details, review the revision history included in any revised document.

### 12.2 Community Resources

The following links connect to TI community resources. Linked contents are provided "AS IS" by the respective contributors. They do not constitute TI specifications and do not necessarily reflect TI's views; see TI's [Terms of Use](#).

**TI E2E™ Online Community** *TI's Engineer-to-Engineer (E2E) Community*. Created to foster collaboration among engineers. At e2e.ti.com, you can ask questions, share knowledge, explore ideas and help solve problems with fellow engineers.

**Design Support** *TI's Design Support* Quickly find helpful E2E forums along with design support tools and contact information for technical support.

### 12.3 Trademarks

E2E is a trademark of Texas Instruments.  
All other trademarks are the property of their respective owners.

### 12.4 Electrostatic Discharge Caution



These devices have limited built-in ESD protection. The leads should be shorted together or the device placed in conductive foam during storage or handling to prevent electrostatic damage to the MOS gates.

### 12.5 Glossary

[SLYZ022](#) — *TI Glossary*.

This glossary lists and explains terms, acronyms, and definitions.

## 13 Mechanical, Packaging, and Orderable Information

The following pages include mechanical, packaging, and orderable information. This information is the most current data available for the designated devices. This data is subject to change without notice and revision of this document. For browser-based versions of this data sheet, refer to the left-hand navigation.

# FK0020A

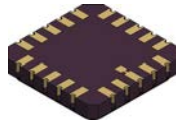

# PACKAGE OUTLINE

## LCCC - 2.03 mm max height

LEADLESS CERAMIC CHIP CARRIER

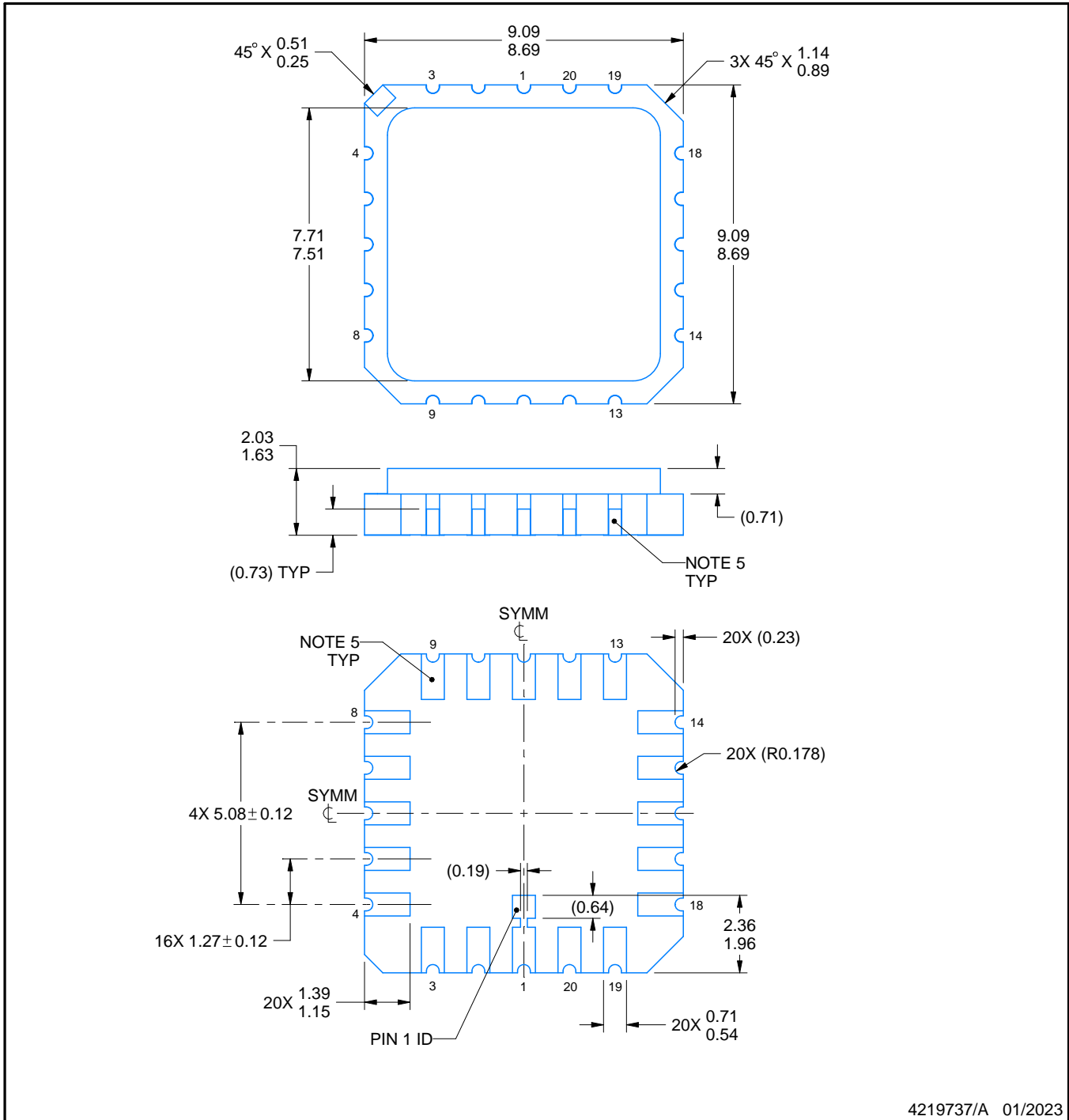

4219737/A 01/2023

### NOTES:

1. All linear dimensions are in millimeters. Any dimensions in parenthesis are for reference only. Dimensioning and tolerancing per ASME Y14.5M.
2. This drawing is subject to change without notice.
3. This package can be hermetically sealed with a metal lid.
4. Reference JEDEC Registration MS-004.
5. The terminals are gold-plated.

# EXAMPLE BOARD LAYOUT

FK0020A

LCCC - 2.03 mm max height

LEADLESS CERAMIC CHIP CARRIER

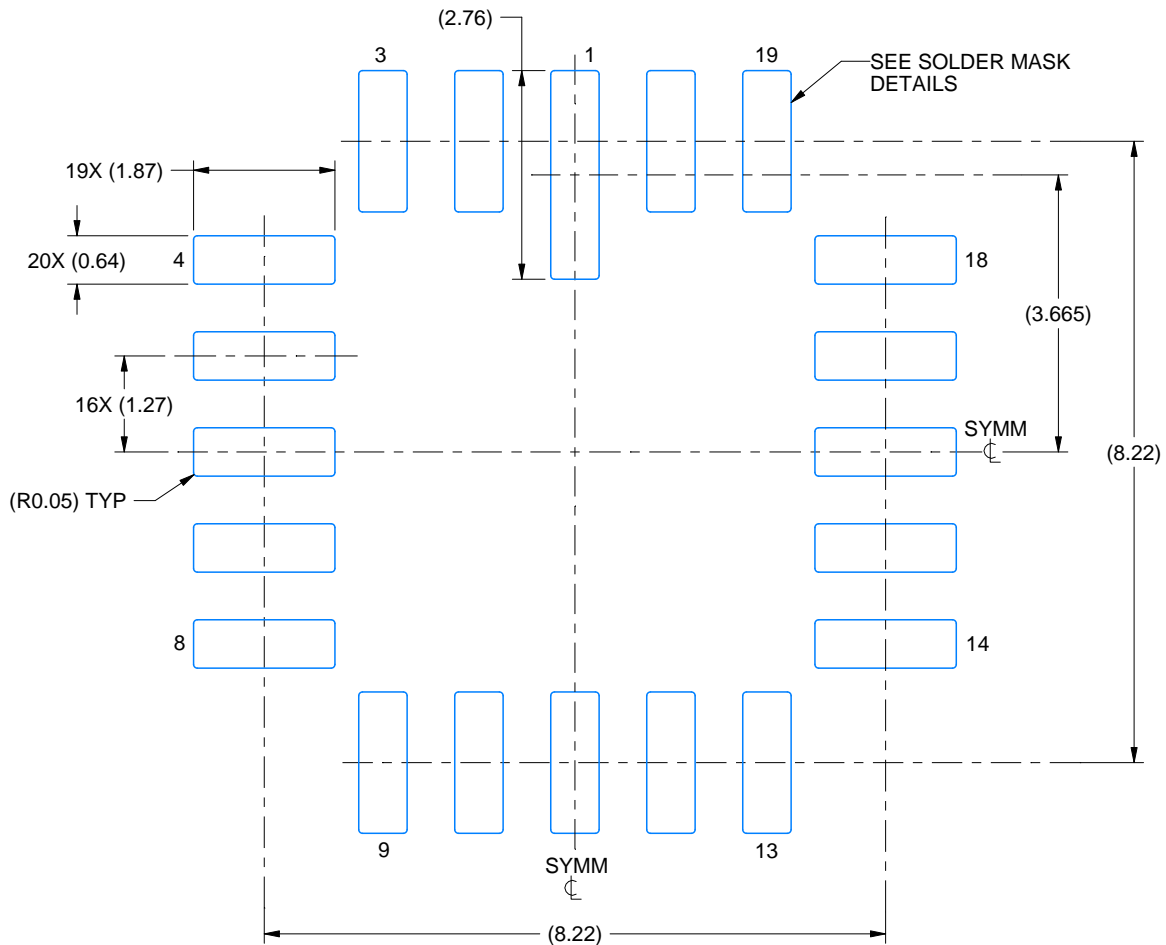

LAND PATTERN EXAMPLE  
EXPOSED METAL SHOWN  
SCALE: 10X

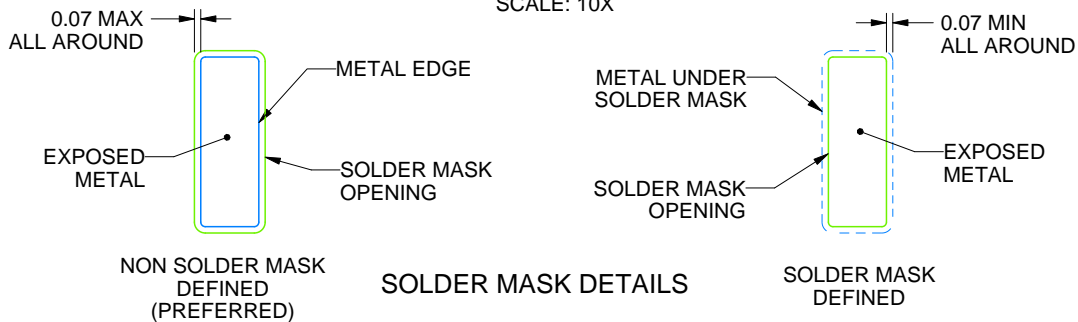

4219737/A 01/2023

NOTES: (continued)

6. For more information, see Texas Instruments literature number SLUA271 ([www.ti.com/lit/slua271](http://www.ti.com/lit/slua271)).



# EXAMPLE STENCIL DESIGN

FK0020A

LCCC - 2.03 mm max height

LEADLESS CERAMIC CHIP CARRIER

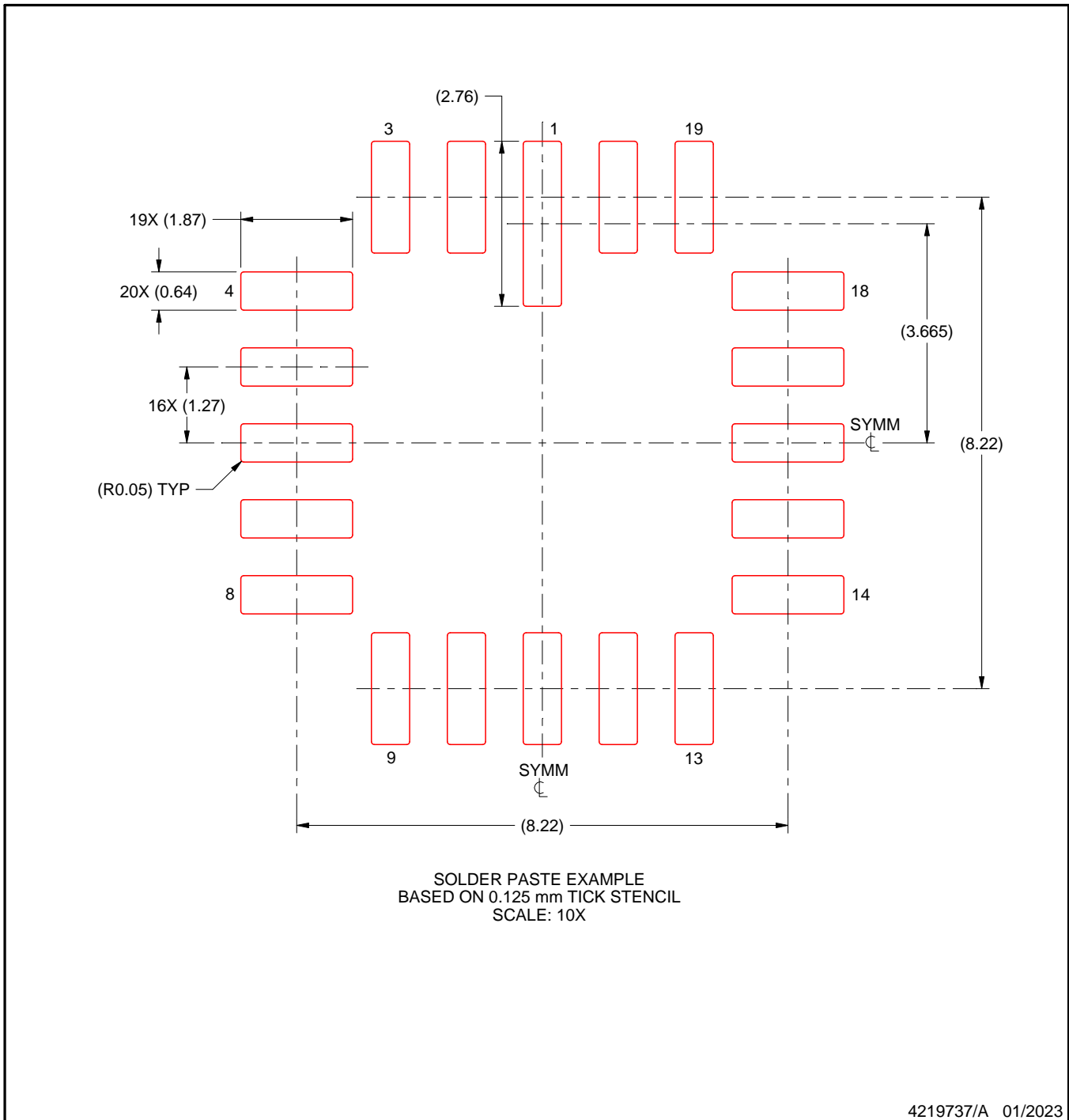

NOTES: (continued)

7. Laser cutting apertures with trapezoidal walls and rounded corners may offer better paste release. IPC-7525 may have alternate design recommendations.

**PACKAGING INFORMATION**

Orderable Device	Status (1)	Package Type	Package Drawing	Pins	Package Qty	Eco Plan (2)	Lead finish/ Ball material (6)	MSL Peak Temp (3)	Op Temp (°C)	Device Marking (4/5)	Samples
5962-8670408VPA	ACTIVE	CDIP	JG	8	1	Non-RoHS & Green	SNPB	N / A for Pkg Type	-55 to 125	8670408VPA UC1845A	<a href="#">Samples</a>
5962-8670408VXA	ACTIVE	LCCC	FK	20	1	Non-RoHS & Green	SNPB	N / A for Pkg Type	-55 to 125	5962- 8670408VXA UC1845AL QMLV	<a href="#">Samples</a>
5962P8670411VPA	ACTIVE	CDIP	JG	8	1	Non-RoHS & Green	SNPB	N / A for Pkg Type	-55 to 125	P8670411VPA UC1845A-SP	<a href="#">Samples</a>
5962P8670411VYC	ACTIVE	CFP	HKU	10	1	RoHS-Exempt & Green	AU	N / A for Pkg Type	-55 to 125	P8670411VYC UC1845A-SP	<a href="#">Samples</a>

(1) The marketing status values are defined as follows:

**ACTIVE:** Product device recommended for new designs.

**LIFEBUY:** TI has announced that the device will be discontinued, and a lifetime-buy period is in effect.

**NRND:** Not recommended for new designs. Device is in production to support existing customers, but TI does not recommend using this part in a new design.

**PREVIEW:** Device has been announced but is not in production. Samples may or may not be available.

**OBSELETE:** TI has discontinued the production of the device.

(2) **RoHS:** TI defines "RoHS" to mean semiconductor products that are compliant with the current EU RoHS requirements for all 10 RoHS substances, including the requirement that RoHS substance do not exceed 0.1% by weight in homogeneous materials. Where designed to be soldered at high temperatures, "RoHS" products are suitable for use in specified lead-free processes. TI may reference these types of products as "Pb-Free".

**RoHS Exempt:** TI defines "RoHS Exempt" to mean products that contain lead but are compliant with EU RoHS pursuant to a specific EU RoHS exemption.

**Green:** TI defines "Green" to mean the content of Chlorine (Cl) and Bromine (Br) based flame retardants meet JS709B low halogen requirements of <=1000ppm threshold. Antimony trioxide based flame retardants must also meet the <=1000ppm threshold requirement.

(3) MSL, Peak Temp. - The Moisture Sensitivity Level rating according to the JEDEC industry standard classifications, and peak solder temperature.

(4) There may be additional marking, which relates to the logo, the lot trace code information, or the environmental category on the device.

(5) Multiple Device Markings will be inside parentheses. Only one Device Marking contained in parentheses and separated by a "-" will appear on a device. If a line is indented then it is a continuation of the previous line and the two combined represent the entire Device Marking for that device.

(6) Lead finish/Ball material - Orderable Devices may have multiple material finish options. Finish options are separated by a vertical ruled line. Lead finish/Ball material values may wrap to two lines if the finish value exceeds the maximum column width.

**Important Information and Disclaimer:**The information provided on this page represents TI's knowledge and belief as of the date that it is provided. TI bases its knowledge and belief on information provided by third parties, and makes no representation or warranty as to the accuracy of such information. Efforts are underway to better integrate information from third parties. TI has taken and continues to take reasonable steps to provide representative and accurate information but may not have conducted destructive testing or chemical analysis on incoming materials and chemicals. TI and TI suppliers consider certain information to be proprietary, and thus CAS numbers and other limited information may not be available for release.

In no event shall TI's liability arising out of such information exceed the total purchase price of the TI part(s) at issue in this document sold by TI to Customer on an annual basis.

**OTHER QUALIFIED VERSIONS OF UC1845A-SP :**

- Catalog : [UC1845A](#)
- Enhanced Product : [UC1845A-EP](#)

NOTE: Qualified Version Definitions:

- Catalog - TI's standard catalog product
- Enhanced Product - Supports Defense, Aerospace and Medical Applications

**TUBE**

\*All dimensions are nominal

Device	Package Name	Package Type	Pins	SPQ	L (mm)	W (mm)	T (μm)	B (mm)
5962-8670408VXA	FK	LCCC	20	1	506.98	12.06	2030	NA
5962P8670411VPA	JG	CDIP	8	1	506.98	15.24	13440	NA
5962P8670411VYC	HKU	CFP	10	1	506.98	26.16	6220	NA



# PACKAGE OUTLINE

## HKU0010A

### CFP - 2.63mm max height

CERAMIC DUAL FLATPACK

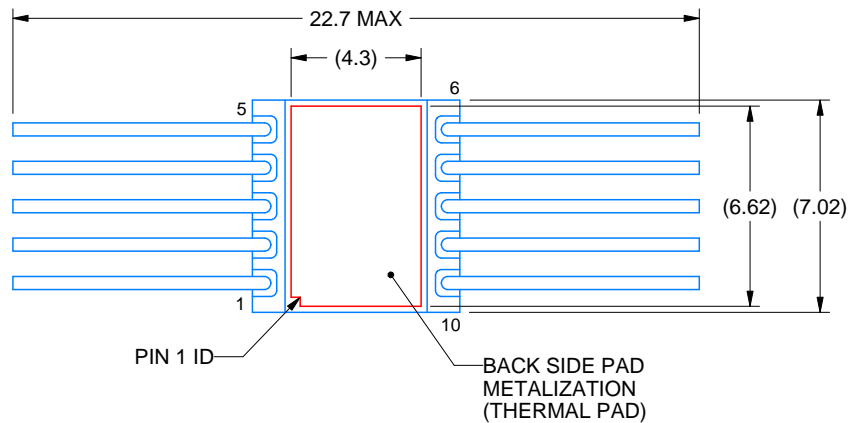
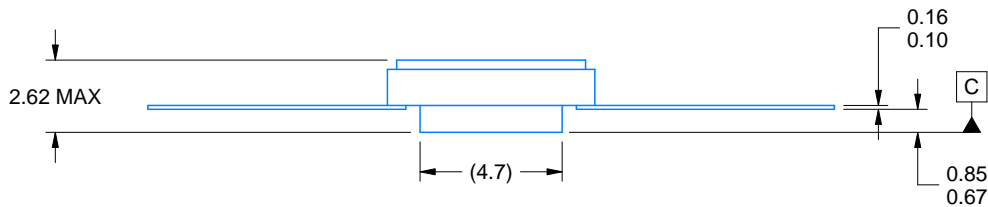
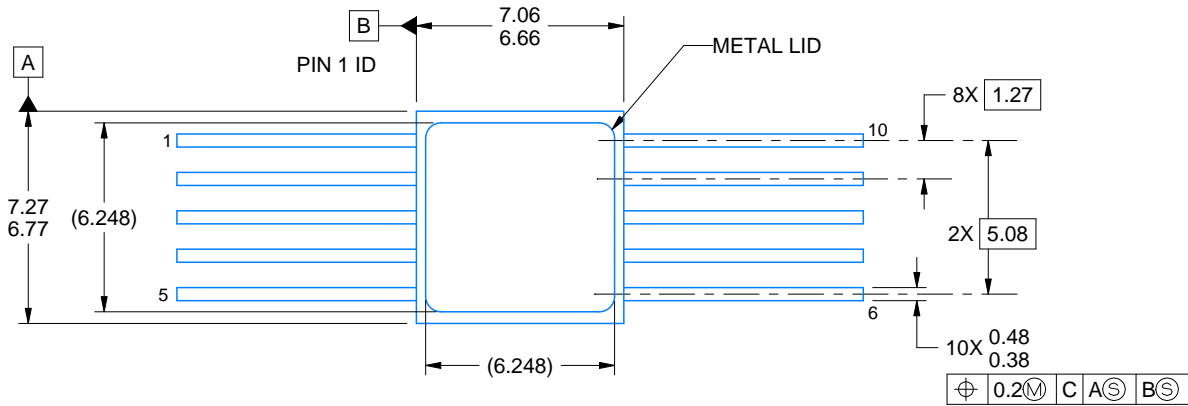

4226200/A 09/2020

#### NOTES:

1. All linear dimensions are in millimeters. Any dimensions in parenthesis are for reference only. Dimensioning and tolerancing per ASME Y14.5M.
2. This drawing is subject to change without notice.
3. This package is hermetically sealed with a metal lid.
4. The terminals are gold plated.
5. This drawing does not comply with MIL STD 1835. Do not use this package for compliant product.
6. Metal lid is connected to back side pad metalization.

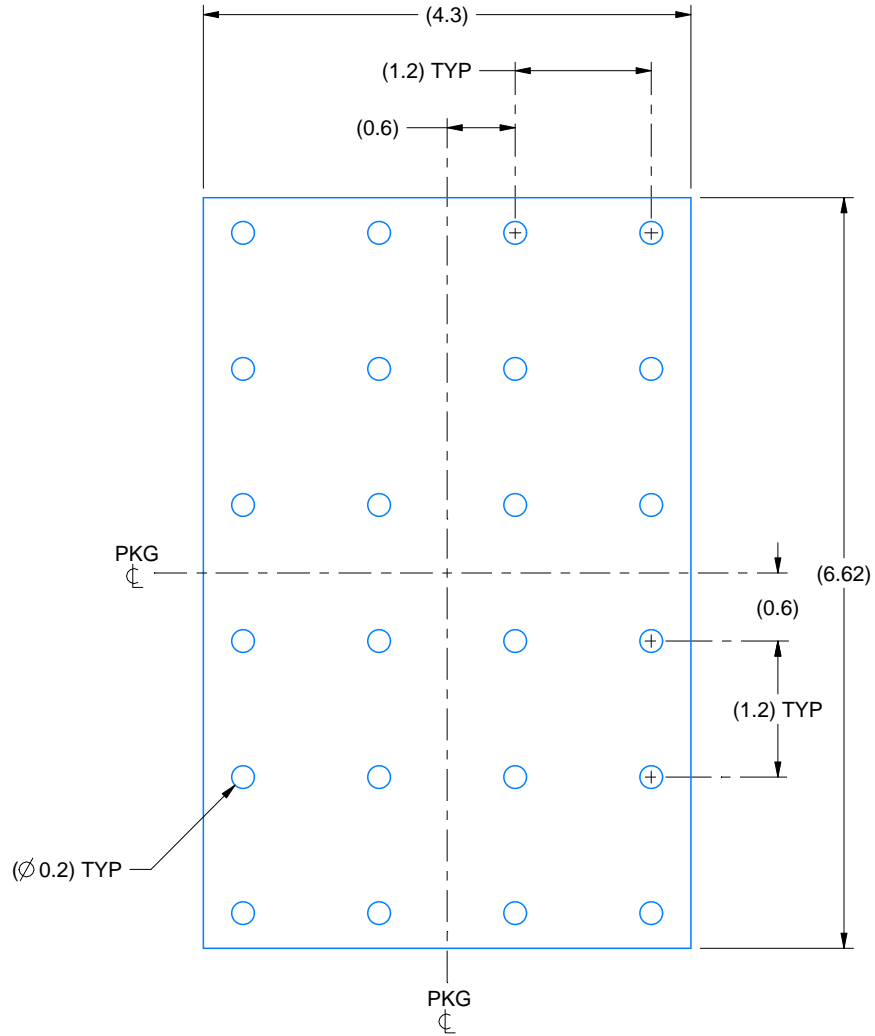

HEATSINK LAND PATTERN EXAMPLE  
EXPOSED METAL SHOWN  
SCALE:15X

## GENERIC PACKAGE VIEW

**FK 20**

**LCCC - 2.03 mm max height**

8.89 x 8.89, 1.27 mm pitch

LEADLESS CERAMIC CHIP CARRIER

This image is a representation of the package family, actual package may vary.  
Refer to the product data sheet for package details.



4229370VA\

JG (R-GDIP-T8)

CERAMIC DUAL-IN-LINE



- NOTES: A. All linear dimensions are in inches (millimeters).  
 B. This drawing is subject to change without notice.  
 C. This package can be hermetically sealed with a ceramic lid using glass frit.  
 D. Index point is provided on cap for terminal identification.  
 E. Falls within MIL STD 1835 GDIP1-T8



## IMPORTANT NOTICE AND DISCLAIMER

TI PROVIDES TECHNICAL AND RELIABILITY DATA (INCLUDING DATA SHEETS), DESIGN RESOURCES (INCLUDING REFERENCE DESIGNS), APPLICATION OR OTHER DESIGN ADVICE, WEB TOOLS, SAFETY INFORMATION, AND OTHER RESOURCES "AS IS" AND WITH ALL FAULTS, AND DISCLAIMS ALL WARRANTIES, EXPRESS AND IMPLIED, INCLUDING WITHOUT LIMITATION ANY IMPLIED WARRANTIES OF MERCHANTABILITY, FITNESS FOR A PARTICULAR PURPOSE OR NON-INFRINGEMENT OF THIRD PARTY INTELLECTUAL PROPERTY RIGHTS.

These resources are intended for skilled developers designing with TI products. You are solely responsible for (1) selecting the appropriate TI products for your application, (2) designing, validating and testing your application, and (3) ensuring your application meets applicable standards, and any other safety, security, regulatory or other requirements.

These resources are subject to change without notice. TI grants you permission to use these resources only for development of an application that uses the TI products described in the resource. Other reproduction and display of these resources is prohibited. No license is granted to any other TI intellectual property right or to any third party intellectual property right. TI disclaims responsibility for, and you will fully indemnify TI and its representatives against, any claims, damages, costs, losses, and liabilities arising out of your use of these resources.

TI's products are provided subject to [TI's Terms of Sale](#) or other applicable terms available either on [ti.com](https://www.ti.com) or provided in conjunction with such TI products. TI's provision of these resources does not expand or otherwise alter TI's applicable warranties or warranty disclaimers for TI products.

TI objects to and rejects any additional or different terms you may have proposed.

Mailing Address: Texas Instruments, Post Office Box 655303, Dallas, Texas 75265  
Copyright © 2023, Texas Instruments Incorporated