

SERPAC 151R2AA (exploded isometric)

Electronic Enclosures

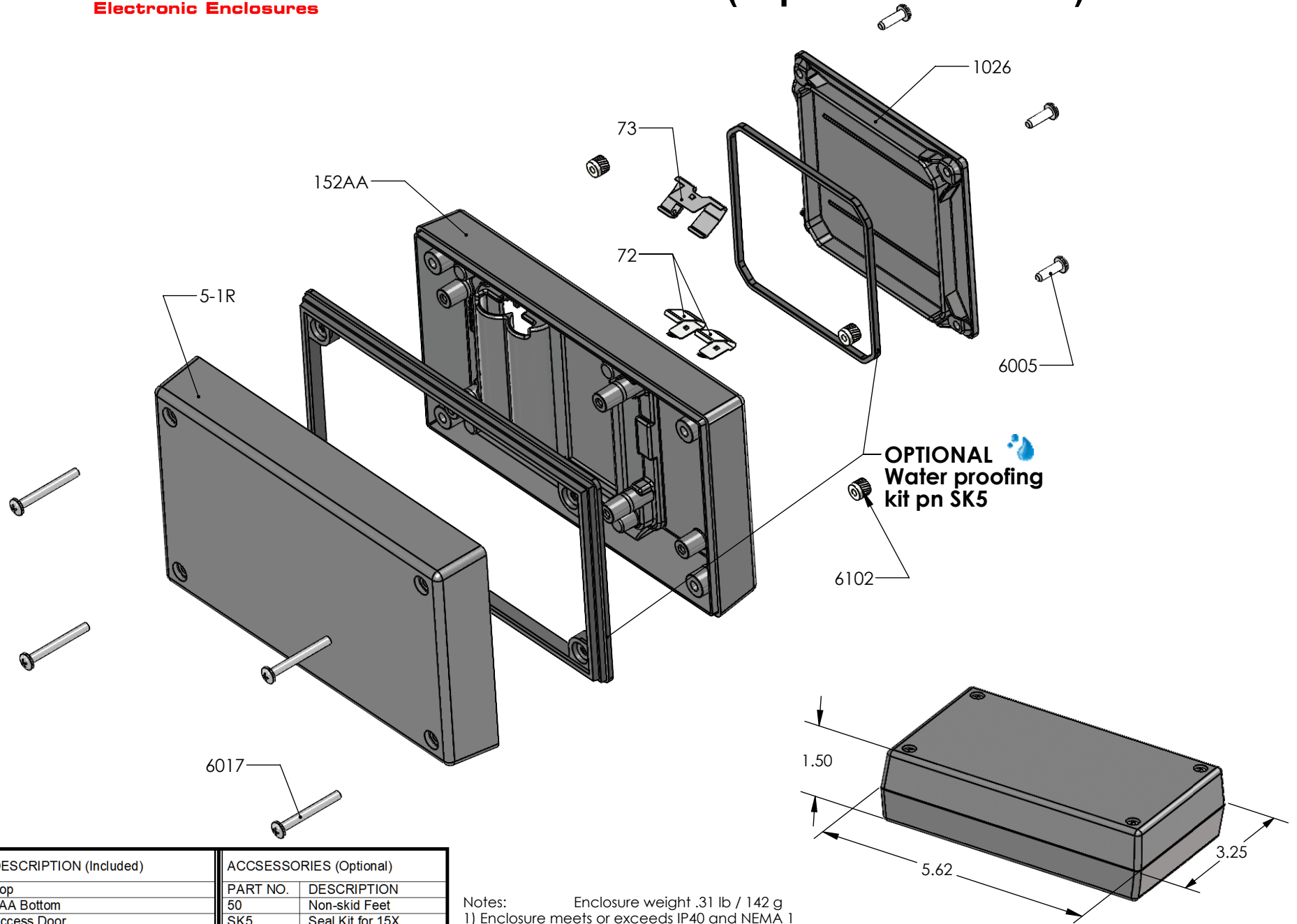

OPTIONAL
Water proofing
kit pn SK5

PART NO.	DESCRIPTION (Included)	ACCESSORIES (Optional)
5-1R	Top	
152AA	2AA Bottom	
1026	Access Door	
6005	#4X3/8" Self-Tapping Screw (4)	
6017	4-40 Screw (4)	
6102	4-40 Threaded Insert (4)	
73	Double Battery Contact (3)	
72	Single Battery Contact (2)	
		PART NO. DESCRIPTION
		50 Non-skid Feet
		SK5 Seal Kit for 15X

- Notes:
- 1) Enclosure weight .31 lb / 142 g
 - 2) When used with SK5 the enclosure meets or exceeds IP 67 and NEMA 4X, 12 and 13 MIL-STD-810G 506.5 (.02 lb / 11g)
 - 3) Circuit Board drawings see sheet 3.
 - 4) All components are RoHS Compliant.

ALL DIMENSIONS ARE ± .010" 5/11/2021 (1 of 3)
2009 Wright Ave. La Verne, CA 91750
Ph. (626) 331-0517 Fx. (626) 331-8584 serpac.com

SERPAC 151R2AA

Electronic Enclosures

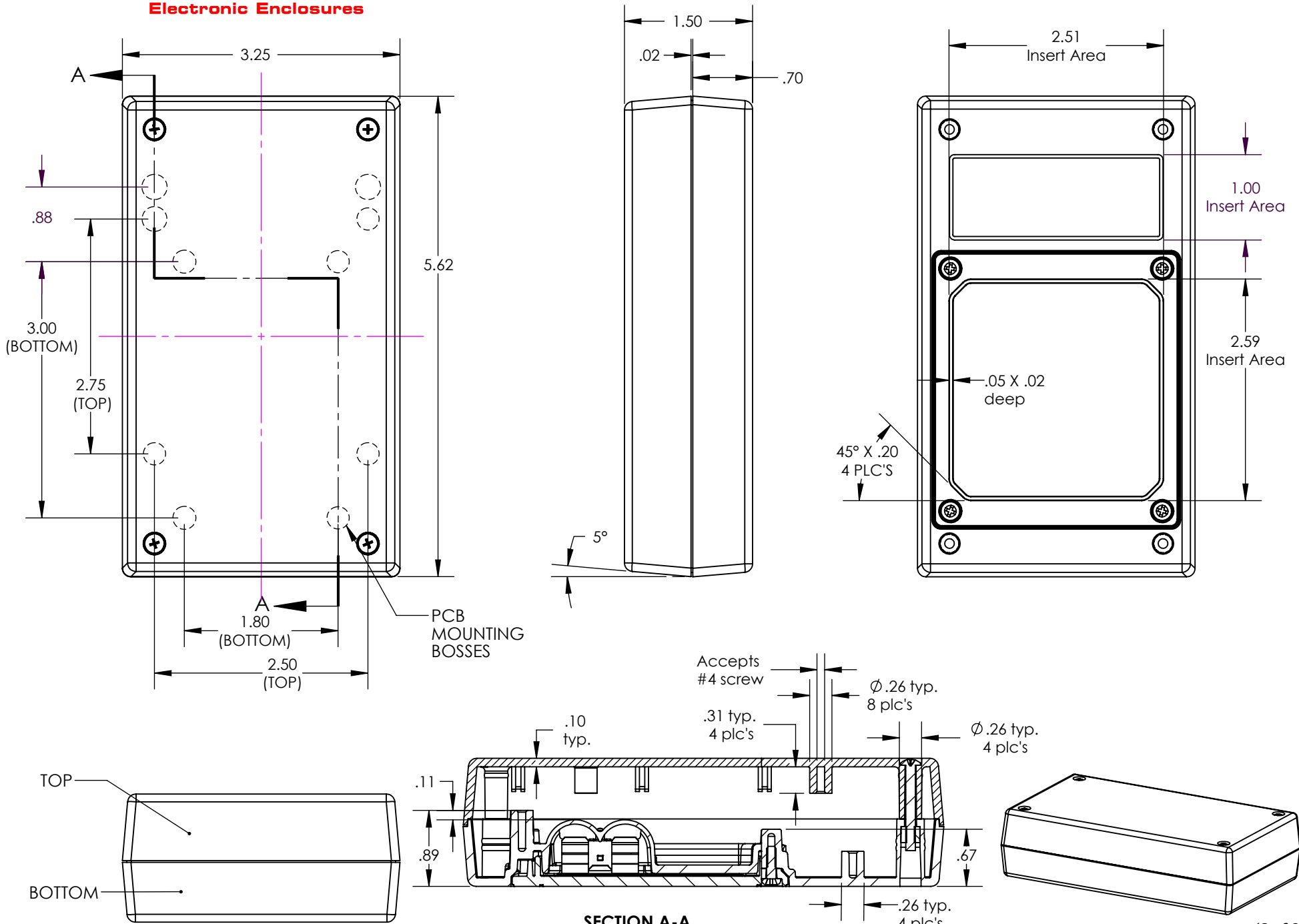

SECTION A-A

ALL DIMENSIONS ARE $\pm .010"$ 5/11/2020 (2 of 3)
2009 Wright Ave. La Verne, CA 91750
Ph. (626) 331-0517 Fx. (626) 331-8584 www.serpac.com

SERPAC PCB for 15X compartment enclosures

Electronic Enclosures

CIRCUIT BOARD FOR TOP

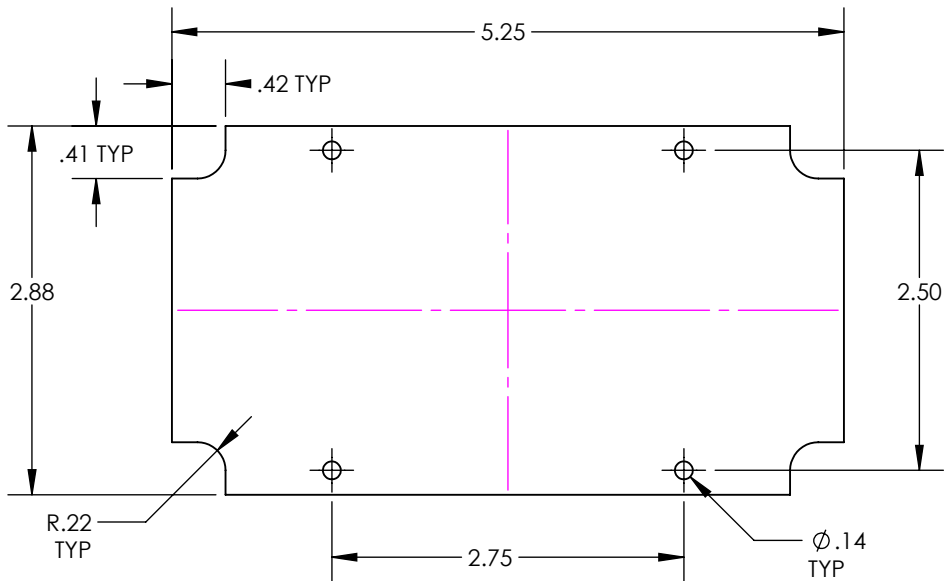

CIRCUIT BOARD FOR BOTTOM

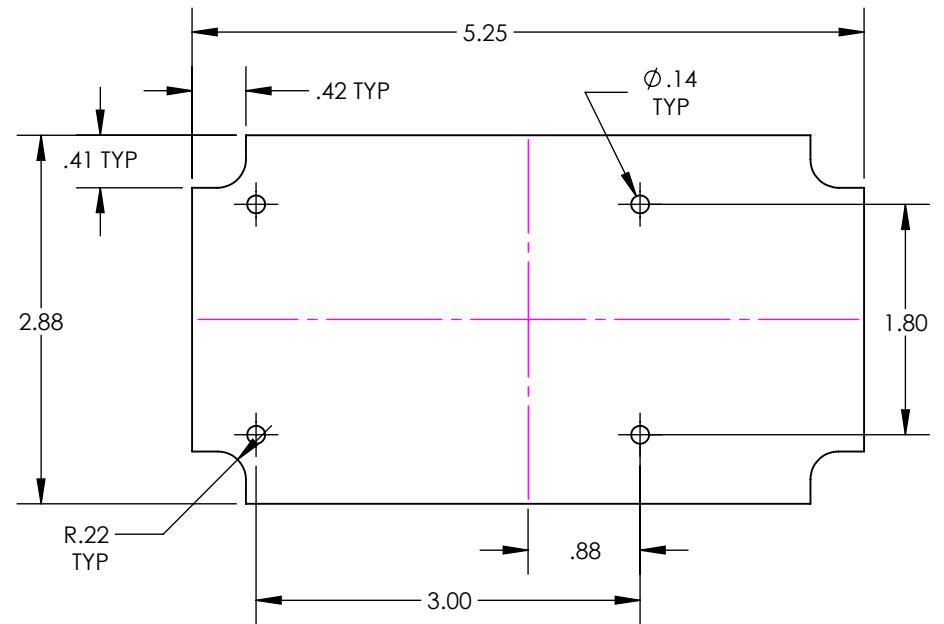

SMALL CIRCUIT BOARD FOR BOTTOM

