Keyboard and Embedded Controller for Notebook PC

Operating Conditions

- Operating Voltages: 3.3 V and 1.8 V
- Operating Temperature Range: -40 °C to 85 °C

Low Power Modes

- Chip is designed to always operate in Lowest Power state during Normal Operation
- Supports all 5 ACPI Power States for PC platforms
- Supports 2 Chip-level Sleep Modes: Light Sleep and Heavy Sleep
 - Low Standby Current in Sleep Modes

ARM® Cortex-M4F Embedded Processor

- Programmable clock frequency up to 48 MHz
- Fixed point processor
- Single 4GByte Addressing Space
- Nested Vectored Interrupt Controller (NVIC)
 - Maskable Interrupt Controller
 - Maskable hardware wake up events
 - 8 Levels of priority, individually assignable by vector
- EC Interrupt Aggregator expands number of Interrupt sources supported or reduces number of vectors needed
- Complete ARM® Standard debug support
 - JTAG-Based DAP port, comprised of SWJ-DP and AHB-AP debugger access functions

Memory Components

- 416KB Code/Data SRAM
 - 352KB optimized for code performance
 - 64KB optimized for data performance
- 128 Bytes Battery Powered Storage SRAM
- 4K bits OTP
 - In circuit programmable
- ROM
 - Contains Boot ROM
 - Contains Runtime APIs for built-in functions
 - 128KB of ROM space

Clocks

- 96 MHz Internal PLL
- 32 kHz Clock Sources
 - Internal 32 kHz silicon oscillator

- External single-ended 32 kHz clock source

Package Options

- 176 pin WFBGA

Security Features

- Boot ROM Secure Boot Loader
 - Hardware Root of Trust (RoT) using Secure Boot and Immutable code
 - Supports 2 Code Images in external SPI Flash (Primary and Fall back image)
 - Authenticates SPI Flash image before loading
 - Support AES-256 Encrypted SPI Flash images
- Hardware Accelerators:
 - Multi purpose AES Crypto Engine:
 - Support for 128-bit - 256-bit key length
 - Supports Battery Authentication applications
 - Digital Signature Algorithm Support
 - Support for ECDSA and EC_KCDSA
 - Cryptographic Hash Engine
 - Support for SHA-1, SHA-256 to SHA-512
 - Public Key Crypto Engine
 - Hardware support for RSA and Elliptic Curve asymmetric public key algorithms
 - RSA keys length of 1024 to 4096 bits
 - ECC Prime Field keys up to 571 bits
 - ECC Binary Field keys up to 571 bits
 - Microcoded support for standard public key algorithms
 - OTP for storing Keys and IDs
 - Lockable on 32 B boundaries to prevent read access or write access
 - True Random Number Generator
 - 1 Kbit FIFO
 - JTAG Disabled by default

System Host interface

- Enhanced Serial Peripheral Interface (eSPI)
 - Intel eSPI Specification compliant
 - eSPI Interface Base Spec, Intel Doc. #327432-004, Rev. 1.0.
 - eSPI Compatibility Spec, Intel Doc. #562633, Rev. 0.6

- Support for Master Attached Flash Sharing (MAFS)
- Support for Slave Attached Flash Sharing (SAFS)
- Supports all four channels:
 - Peripheral Channel
 - Virtual Wires Channel
 - Out-of-Band (OOB) Tunneled Message Channel
 - Run-time Flash Access Channel
- Supports EC Bus Master to Host Memory
- Supports up to 66 MHz maximum operating frequency
- One Serial Peripheral Interface (SPI) Slave
 - Quad SPI (half-duplex) or Single wire (full duplex) support
 - Mode 0 and Mode3 operation
 - Programmable wait time for response delay
- System to EC Message Interface
 - Three Embedded Memory Interfaces
 - Provides Two Windows to On-Chip SRAM for Host Access
 - Two Register Mailbox Command Interface
 - Mailbox Registers Interface
 - Thirty-two 8-bit registers
 - Two Register Mailbox Command Interfaces
 - Two Register SMI Source Interfaces
 - Six ACPI Embedded Controller Interfaces
 - Five EC Interfaces
 - One Power Management Interface
- One Serial Peripheral Interface (SPI) Master Controller
 - Dual and Quad I/O Support
 - Flexible Clock Rates
 - Support for 1.8V and 3.3V slave devices
 - SPI Burst Capable
 - SPI Controller Operates with Internal DMA Controller with CRC Generation
 - Mappable to the following ports (only 1 port active at a time)
 - 1 shared SPI Interface
 - 1 Private SPI Interface
- Two General purpose Serial Peripheral Interface (SPI) Controllers
 - One EC driven Full Duplex Serial Communication Interface
 - Flexible Clock Rates
 - SPI burst capable
- PECl Interface 3.1
 - Support Intel's low voltage PECl
- Port 80 BIOS Debug Port

- Two Ports, Assignable to Any eSPI IO Address
- 24-bit Timestamp with Adjustable Timebase
- 16-Entry FIFO

Peripheral Features

- Internal DMA Controller
 - Hardware or Firmware Flow Control
 - Firmware Initiated Memory-to-Memory transfers
 - Hardware CRC-32 Generator on Channel 0
- I2C/SMBus Controllers
 - 5 I2C/SMBus controllers
 - 15 Configurable I2C ports
 - Full Crossbar switch allows any port to be connected to any controller
 - Supports Promiscuous mode of operation
 - Fully Operational on Standby Power
 - Multi-Master Capable
 - Supports Clock Stretching
 - Programmable Bus Speeds
 - 1 MHz Capable
 - Supports DMA Network Layer
- General Purpose I/O Pins
 - Inputs
 - Asynchronous rising and falling edge wakeup detection Interrupt High or Low Level
 - Outputs:
 - Push Pull or Open Drain output
 - Programmable power well emulation
 - Pull up or pull down resistor control
 - Automatically disabling pull-up resistors when output driven low
 - Automatically disabling pull-down resistors when output driven high
 - Programmable drive strength
 - Two separate 1.8V/3.3V configurable IO regions
 - Group or individual control of GPIO data
 - 13- Over voltage tolerant GPIO pins
 - Glitch protection and Under-Voltage Protection on all GPIO pins
 - 8 GPIO Pass through ports
- Input Capture and Compare timer
 - Six 32-bit Capture Registers
 - 16 Input Pins (ICTx)
 - Full Crossbar switch allows any port to be connected to any controller
 - 32-bit Free-running timer
 - Two 32-bit Compare Registers
 - Capture, Compare and Overflow Interrupts

- Universal Asynchronous Receiver Transmitter (UART)
 - Two High Speed NS16C550A Compatible UARTs with Send/Receive 16-Byte FIFOs
 - UART0 - Configurable 2-pin/4-pin/8-pin
 - UART1 - Configurable 2-pin/4-pin
 - Programmable Main Power or Standby Power Functionality
 - Standard Baud Rates to 115.2 Kbps, Custom Baud Rates to 1.5 Mbps
 - Programmable Timer Interface
 - Two 16-bit Auto-reloading Timer Instances
 - 16 bit Pre-Scale divider
 - Halt and Reload control
 - Auto Reload
 - Two 32-bit Auto-reloading Timer Instances
 - 16 bit Pre-Scale divider
 - Halt and Reload control
 - Auto Reload
 - Three Operating Modes per Instance: Timer (Reload or Free-Running) or One-shot.
 - Event Mode is not supported
 - 32-bit RTOS Timer
 - Runs Off 32kHz Clock Source
 - Continues Counting in all the Chip Sleep States regardless of Processor Sleep State
 - Counter is Halted when Embedded Controller is Halted (e.g., JTAG debugger active, break points)
 - Generates wake-capable interrupt event
 - Watch Dog Timer (WDT)
 - Watchdog reset IRQ vector
 - Embedded Reset Engine
 - Resets the EC if external VCI_IN0# pin is held low for a programmed time
 - 12 Programmable Pulse Width Modulator (PWM) outputs
 - Multiple Clock Rates
 - 16-Bit ON & 16-Bit OFF Counters
 - 4 Fan Tachometer Inputs
 - 16 Bit Resolution
 - Two RPM-Based Fan Speed Controllers
 - Each includes one Tach input and one PWM output
 - Each includes one Tach input and one PWM output
 - 3% accurate from 500 RPM to 16k RPM
 - Automatic Tachometer feedback
 - Aging Fan or Invalid Drive Detection
 - Spin Up Routine
 - Ramp Rate Control
 - RPM based Fan Control Algorithm
 - Breathing LED Interface
 - 4 Blinking/Breathing LEDs
 - Programmable Blink Rates
 - Piecewise Linear Breathing LED Output Controller
 - Provides for programmable rise and fall waveforms
 - Operational in EC Sleep States
 - PS2 Controller
 - One PS2 controllers
 - Two PS2 ports
 - Both ports are 5 volt tolerant
 - PROCHOT interface with Two instances of the Power guard™ Technology
 - Monitor for single assertions or cumulative PROCHOT active time
 - Interrupt generation for PROCHOT assertion events
 - Support PROCHOT assertions to external CPU
 - Power guard™ technology monitors total system power via dedicated Fast A/D converter
 - Two programmable thresholds with hysteresis and filtering for each V_ISYS input
 - Integrated with PROCHOT interface to provide CPU throttling
 - Fast programmable response on high threshold
 - Programmable delayed response on low threshold
 - Microchip BC-Link Interconnection Bus
 - One High/Low speed Bus master controller
 - 3 RC-ID ports
 - Single pin interface to External Inexpensive RC circuit
 - Replacement for Multiple GPIOs
 - Provides 8 quantized states on One pin
- ## Analog Features
- ADC Interface
 - 10-bit or 12-bit readings supported
 - ADC Conversion time 500nS/channel
 - 16 Channels
 - External voltage reference
 - Supports thermistor temperature readings
- ## Battery Powered Peripherals
- Real Time Clock (RTC)
 - VBAT Powered
 - 32KHz Crystal Oscillator or External single-ended 32 kHz clock source
 - Time-of-Day and Calendar Registers
 - Programmable Alarms

MEC1725

- Supports Leap Year and Daylight Savings Time
- Hibernation Timer Interface
 - Two 32.768 KHz Driven Timers
 - Programmable Wake-up from 0.5ms to 128 Minutes
- Week Timer
 - System Power Present Input Pin
 - Week Alarm Event only generated when System Power is Available
 - Power-up Event
 - Week Alarm Interrupt with 1 Second to 8.5 Year Time-out
 - Sub-Week Alarm Interrupt with 0.50 Seconds - 72.67 hours time-out
 - 1 Second and Sub-second Interrupts
- VBAT-Powered Control Interface (VCI)
 - 4 Active-low VCI Inputs
 - 1 Active-high VCI Output Pin
 - System Power Present Detection for gating RTC wake events
 - Optional filter and latching
- 4 Battery-Powered General Purpose Output (BGPO) Pins

Debug Features

- 2-pin Serial Wire Debug (SWD) interface
- 4-Pin JTAG interface for Boundary Scan
- 1-Pin ITM interface
- Trace FIFO Debug Port (TFDP)

TO OUR VALUED CUSTOMERS

It is our intention to provide our valued customers with the best documentation possible to ensure successful use of your Microchip products. To this end, we will continue to improve our publications to better suit your needs. Our publications will be refined and enhanced as new volumes and updates are introduced.

If you have any questions or comments regarding this publication, please contact the Marketing Communications Department via E-mail at docerrors@microchip.com. We welcome your feedback.

Most Current Data Sheet

To obtain the most up-to-date version of this data sheet, please register at our Worldwide Web site at:

<http://www.microchip.com>

You can determine the version of a data sheet by examining its literature number found on the bottom outside corner of any page. The last character of the literature number is the version number, (e.g., DS30000000A is version A of document DS30000000).

Errata

An errata sheet, describing minor operational differences from the data sheet and recommended workarounds, may exist for current devices. As device/documentation issues become known to us, we will publish an errata sheet. The errata will specify the revision of silicon and revision of document to which it applies.

To determine if an errata sheet exists for a particular device, please check with one of the following:

- Microchip's Worldwide Web site; <http://www.microchip.com>
- Your local Microchip sales office (see last page)

When contacting a sales office, please specify which device, revision of silicon and data sheet (include -literature number) you are using.

Customer Notification System

Register on our web site at www.microchip.com to receive the most current information on all of our products.

MEC1725

Table of Contents

1.0 General Description	7
2.0 Pin Configuration	12
3.0 Device Inventory	59
4.0 Power, Clocks, and Resets	128
5.0 ARM M4 Based Embedded Controller	153
6.0 RAM and ROM	163
7.0 Internal DMA Controller	165
8.0 EC Interrupt Aggregator	181
9.0 Chip Configuration	190
10.0 Enhanced Serial Peripheral Interface (eSPI)	195
11.0 I2C/SMBus Interface	207
12.0 8042 Emulated Keyboard Controller	212
13.0 ACPI Embedded Controller Interface (ACPI-ECI)	230
14.0 ACPI PM1 Block	250
15.0 Embedded Memory Interface (EMI)	257
16.0 Mailbox Interface	272
17.0 UART	280
18.0 GPIO Interface	298
19.0 Watchdog Timer (WDT)	315
20.0 16/32 Bit Basic Timer	321
21.0 16-Bit Counter-Timer Interface	328
22.0 Input Capture and Compare Timer	343
23.0 Hibernation Timer	358
24.0 RTOS Timer	361
25.0 Real Time Clock	366
26.0 Week Timer	378
27.0 TACH	391
28.0 PWM	398
29.0 PECE Interface	403
30.0 Analog to Digital Converter	412
31.0 RC Identification Detection (RC_ID)	425
32.0 Blinking/Breathing LED	432
33.0 PROCHOT Monitor	448
34.0 PowerGuard	457
35.0 RPM-PWM Interface	478
36.0 Keyboard Scan Interface	497
37.0 Environmental Monitor	504
38.0 Quad SPI Master Controller	545
39.0 General Purpose Serial Peripheral Interface	570
40.0 BC-Link Master	589
41.0 PS/2 Interface	596
42.0 Trace FIFO Debug Port (TFDP)	604
43.0 Port 80 32-Bit BIOS Debug Port	608
44.0 VBAT-Powered Control Interface	623
45.0 VBAT-Powered RAM	635
46.0 VBAT Register Bank	637
47.0 EC Subsystem Registers	641
48.0 Security Features	651
49.0 OTP Block	655
50.0 Glue (VCC Power-Good Generation) Logic	658
51.0 Test Mechanisms	666
52.0 Electrical Specifications	667
53.0 Timing Diagrams	686
The Microchip Web Site	717
Customer Change Notification Service	717
Customer Support	717
Appendix A: Data Sheet Revision History	718
Product Identification System	719

1.0 GENERAL DESCRIPTION

The MEC1725 is a family of low power integrated embedded controller designed for notebook applications storage enclosure platforms. The MEC1725 is a highly-configurable, mixed-signal, advanced I/O controller. It contains a 32-bit ARM® Cortex-M4F processor core with closely-coupled memory for optimal code execution and data access. An internal ROM, embedded in the design, is used to store the power on/boot sequence and APIs available during run time. When **VTR_CORE** is applied to the device, the secure bootloader API is used to download the custom firmware image from the system's shared SPI Flash device, thereby allowing system designers to customize the device's behavior.

The MEC1725 device is directly powered by a minimum of two separate suspend supply planes (**VBAT** and **VTR**) and senses a third runtime power plane (**VCC**) to provide "instant on" and system power management functions. The MEC1725 has two banks of I/O pins that are able to operate at either 3.3 V or 1.8 V. Operating at 1.8V allows the MEC1725 to interface with the latest platform controller hubs and will lower the overall power consumed by the device, Whereas 3.3V allows this device to be integrated into legacy platforms that require 3.3V operation.

The MEC1725 host interface is the Intel® Enhanced Serial Peripheral Interface (eSPI). The eSPI Interface is a 1.8V interface that operates in single, double and quad I/O modes. The eSPI Interface supports all four eSPI channels: Peripheral Channel, Virtual Wires Channel, OOB Message Channel, and Run-time Flash Access Channel. The eSPI hardware Flash Access Channel is used by the Boot ROM to support Master Attached Flash Sharing (MAFS). In addition, the MEC1725 has specially designed hardware to support Slave Attached Flash Sharing (SAFS). The eSPI SAFS Bridge imposes Region-Based Protection and Locking security feature, which limits access to certain regions of the flash to specific masters. There may be one or more masters (e.g., BIOS, ME, etc) that will access the SAF via the eSPI interface. The ARM® Cortex-M4F processor is also considered a master, which will also have its access limited to EC only regions of SPI Flash as determined by the customer firmware application. The MEC1725 secure bootloader authenticates and optionally decrypts the SPI Flash OEM boot image using the AES-256, ECDSA, SHA-512 cryptographic hardware accelerators. The MEC1725 hardware accelerators support 128-bit and 256-bit AES encryption, ECDSA and EC_KCDSA signing algorithms, 1024-bits to 4096-bits RSA and Elliptic asymmetric public key algorithms, and a True Random Number Generator (TRNG). Runtime APIs are provided in the ROM for customer application code to use the cryptographic hardware. Additionally, the device offers lockable OTP storage for private keys and IDs.

The MEC1725 is designed to be incorporated into low power PC architecture designs and supports ACPI sleep states (S0-S5). During normal operation, the hardware always operates in the lowest power state for a given configuration. The chip power management logic offers two low power states: light sleep and heavy sleep. These features can be used to support S0 Connected Standby state and the lower ACPI S3-S5 system sleep states. In connected standby, any eSPI command will wake the device and be processed. When the chip is sleeping, it has many wake events that can be configured to return the device to normal operation. Some examples of supported wake events are PS2 wake events, RTC, Week Alarm, Hibernation Timer, or any GPIO pin.

The MEC1725 offers a software development system interface that includes a Trace FIFO Debug port, a host accessible serial debug port with a 16C550A register interface, a Port 80 BIOS Debug Port, and a 2-pin Serial Wire Debug (SWD) interface. Also included is a 4-wire JTAG interface used for Boundary Scan testing.

The MEC1725 also supports eSPI host interface, with Master attached Flash and Slave attached Flash Sharing in the 144 pin package

1.1 Family Features

TABLE 1-1: MEC1725 FEATURE LIST

MEC1725 Product Features	MEC1725N-B0-I/LJ
Device ID	0x002257XX
JTAG ID	0x02242445
Package	176 WFBGA
Total SRAM Options	416KB
Code/Data Options (Primary Use)	352KB/64KB
Battery Backed SRAM	128 bytes

MEC1725

MEC1725 Product Features	MEC1725N-B0-I/LJ
EEPROM Controller Supports 2KB	No
Internal SPI	No
EMC2016 (as MCM)	Yes
Power Guard (Optional)	2
Thermal Diode Support	8
Prochot Monitor input only (Optional)	Yes
Prochot Monitor IO (bidi pin) (Optional)	Yes
2 pin SWD	Yes
4 pin JTAG	Yes
eSPI Host Interface	Yes
eSPI SAF Interface	Yes
GPIO Support through eSPI Virtual Wire	Yes
RPMC	Yes
8042 Emulated Keyboard Controller	Yes
Embedded Memory Interface (EMI)	3
Mailbox Register Interface	1
ACPI Embedded Memory Controller Interface	5
ACPI PM1 Block Interface	1
Trace FIFO Debug Port	Yes
Internal DMA Channels	16
16-bit Basic Timer	4
32-bit Basic Timer	2
16-bit Counter/Timer	4
Capture Timer	2
ICT Channels	16
Compare Timer	2
Watchdog Timer (WDT)	1
Hibernation Timer	2
Week Timer	1
Sub Week Timer	1
RTC	1
RTOS Timer	1
Battery-Powered General Purpose Output (BGPO)	1
BGPO Multiplexed with GPIO's	5
Active Low VBAT-Powered Control Interface (VCI)	5
Active high VBAT-Powered Control Interface (VCI_OVRD_IN)	1
VCI_OUT	1
Keyboard Matrix Scan Support	Yes
Port 80 BIOS Debug Port	2

MEC1725 Product Features	MEC1725N-B0-I/LJ
SMBus Network 2.0/ I2C Master Controllers	5
SMBus Ports	16
PECI 3.1 Interface	Yes
PS/2 Device Interface	1 controller/ 2 ports
GPIOs	141
Blinking/Breathing LED	4
General Purpose SPI Master Controller	2
Quad SPI Master Controller	1 controller/ 3 ports
10/12-bit ADC Channels	16
Vref-2 ADC	Yes
RPM2PWM	2
16-bit PWMs	12
16-bit TACHs	4
UARTs	2 UART0: 8-pin UART1: 8-pin
AES Hardware Support	128-256 bit
SHA 1, SHA 2 and Hashing Support	SHA-1 to SHA-2
Public Key Cryptography Support	RSA: 4K bit ECC: 571 bit
True Random Number Generator with health test	1K bit
User OTP	4K bits
Analog Comparator	No
5V Tolerant Pads	12
GPIO Pass Through Ports (GTP)	8
BC-Link	1
RC-ID	3
Differential Power Analysis countermeasures (DPA)	Yes
Root Of Trust	Yes
Secure Boot	Yes
Immutable Code	Yes
Key Revocation	Yes
Key Roll Back Protection	127

Note 1: Please refer to Boot ROM document for below set of optional OTP selectable features.

MEC1725

1.2 Boot ROM

Following the release of the [RESET_EC](#) signal, the processor will start executing code from the Boot ROM. The Boot ROM executes the SPI Flash Loader, which downloads User Code from SPI Flash and stores it in the internal Code RAM. Refer to MEC1725 Boot ROM document for further details.

1.3 MEC1725 Internal Address Spaces

The Internal Embedded Controller can access any register in the EC Address Space or Host Address Space. If the I²C interface is used as the Host Interface, access to all the IP Peripherals is dependent on EC firmware.

FIGURE 1-1: BLOCK DIAGRAM

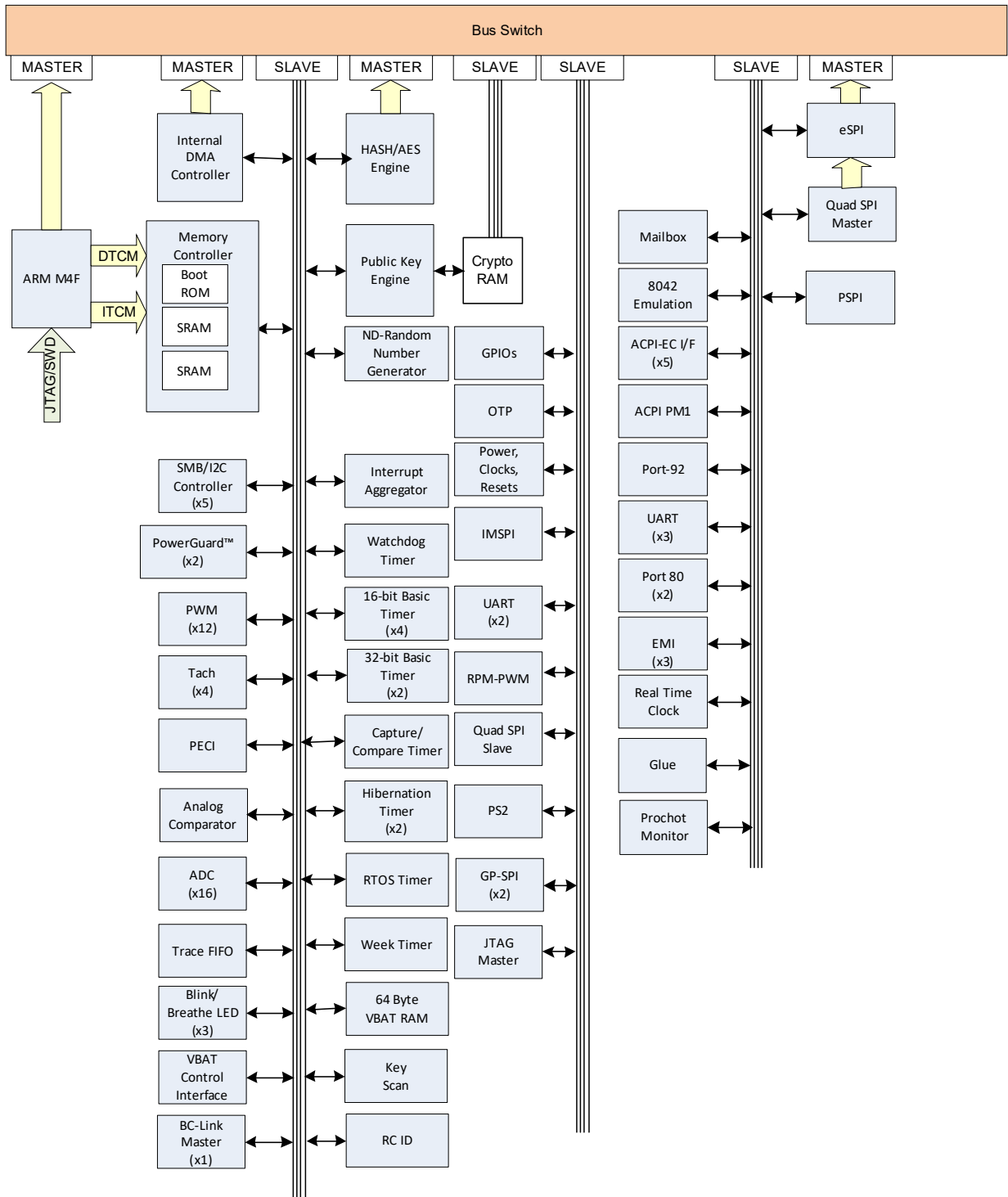

MEC1725

2.0 PIN CONFIGURATION

2.1 Description

The Pin Configuration chapter includes [Pin List](#), [Pin Multiplexing](#) and [Package Information](#).

2.2 Terminology and Symbols for Pins/Buffers

2.2.1 BUFFER TERMINOLOGY

Term	Definition
#	The '#' sign at the end of a signal name indicates an active-low signal
n	The lowercase 'n' preceding a signal name indicates an active-low signal
PWR	Power
PIO	Programmable as Input, Output, Open Drain Output, Bi-directional or Bi-directional with Open Drain Output. Configurable drive strength from 2ma to12ma. Note: All GPIOs have programmable drive strength options. GPIO pin drive strength is determined by the Pin Control Register Defaults field in the Pin Control Register 2 .
In	I Type Input Buffer.
O2	O-2 mA Type Buffer.
PECI	PECI Input/Output. These pins operate at the processor voltage level (VREF_VTT)
SB-TSI	SB-TSI Input/Output. These pins operate at the processor voltage level (VREF_VTT)
High Drive Pad	Configurable drive strength of 4,8,16,24 mA

2.2.2 PIN NAMING CONVENTIONS

- Pin Name is composed of the multiplexed options separated by '/'. E.g., GPIOxxxx/SignalA/SignalB.
- The first signal shown in a pin name is the default signal. E.g., GPIOxxxx/SignalA/SignalB means the GPIO is the default signal.
- Parenthesis '(') are used to list aliases or alternate functionality for a single mux option. For example, GPIO062(RESETO#) has only a single mux option, GPIO062, but the signal GPIO062 can also be used or interpreted as RESETO#.
- Square brackets '['] are used to indicate there is a Strap Option on a pin. This is always shown as the last signal on the Pin Name.
- Signal Names appended with a numeric value indicates the Instance Number. E.g., PWM0, PWM1, etc. indicates that PWM0 is the PWM output for PWM Instance 0, PWM1 is the PWM output for PWM Instance 1, etc. The instance number may be omitted if there is only one instance of the IP block implemented.

2.3 Pin List

TABLE 2-1: MEC1725 176 WFBGA PINOUT

Pin Map	Signal
E5	VCI_IN3#/GPIO000
D3	GPIO033/TACH3/RC_ID0
E3	GPIO022/GPTP_IN4/32kHz_OUT_ALT
C2	GPIO023/GPTP_IN7
F3	GPIO024(nRESET_IN)
D2	GPIO221/32kHz_OUT/GPTP_IN3
C1	GPIO057/VCC_PWRGD
B2	GPIO106/PWROK
B1	GPIO226/PWRGD_S0iX

TABLE 2-1: MEC1725 176 WFBGA PINOUT

Pin Map	Signal
E2	GPIO060/KBRST/TST_- CLK_OUT/UART1_DCD#/SPI0_CS1#
F2	GPIO051/ICT1_TACH1/GTACH1
F1	GPIO050/ICT0_TACH0/GTACH0
G5	GPIO200/ADC00
J5	GPIO201/ADC01
G3	GPIO202/ADC02
J1	GPIO203/ADC03
K2	GPIO204/ADC04
K4	GPIO205/ADC05
L3	GPIO206/ADC06
L4	GPIO207/ADC07
M2	GPIO064/SLP_S0#
M3	GPIO067/VREF2_ADC
N2	GPIO066/ESPI_CS#/I2C13_SDA
M4	GPIO061/ESPI_RESET#
P2	GPIO065/ESPI_CLK/I2C13_SCL/ICT5_ALT
N3	GPIO070/ESPI_IO0/I2C14_SDA
P3	GPIO071/ESPI_IO1/I2C14_SCL
N4	GPIO072/ESPI_IO2/I2C01_SDA_ALT
P4	GPIO073/ESPI_IO3/I2C01_SCL_ALT
L5	GPIO100/nEC_SCI_ALT/ICT6
K6	GPIO011/nSMI_ALT/PWM4/ICT7
M5	GPIO063/ESPI_ALERT#/PWM6_ALT/ICT8
M6	GPIO222/PROCHOT_IN#_ALT
M7	GPIO224/GPTP_IN0/SHD_IO1
N5	GPIO016/GPTP_IN1/SHD_IO3/ICT3(DSW_PWROK)
N6	GPIO227/SHD_IO2[PWRGD_STRAP]
P6	GPIO223/SHD_IO0
P5	GPIO055/PWM2/SHD_CS0#[BSS_STRAP]
N7	GPIO056/PWM3/SHD_CLK
L1	GPIO012/I2C07_SDA/SLV_SPI_IO2/TOUT3
K7	GPIO013/I2C07_SCL/SLV_SPI_IO3/TOUT2
N1	GPIO130/I2C01_SDA/SLV_SPI_IO0/TOUT1
M1	GPIO131/I2C01_SCL/SLV_SPI_CS#/TOUT0
P1	GPIO020/KSI1
N8	GPIO021/KSI2
K8	GPIO052/ICT2_TACH2
P8	GPIO002/PWM5/SHD_CS1#
P9	GPIO014/PWM6/SLV_SPI_IO1/GPTP_IN2
M9	GPIO015/PWM7/ICT10
M10	GPIO151/ICT4/KSO15
N11	GPIO152/KSO14/GPTP_OUT3
N10	GPIO017/KSI0/UART0_DCD#/GPTP_IN5
P12	GPIO040/GPTP_OUT2/KSO00

MEC1725

TABLE 2-1: MEC1725 176 WFBGA PINOUT

Pin Map	Signal
P10	GPIO032/KSI7/GPTP_OUT0/UART0_RI#
N12	GPIO031/KSI6/GPTP_OUT1
P13	GPIO132/I2C06_SDA/KSO16
P11	GPIO140/I2C06_SCL/ICT5/KSO17
M11	GPIO115/PS2_DAT0A
L10	GPIO025/nEMI_INT/UART_CLK/UART1_RI#/TIN0
P14	GPIO026/KSI3/I2C12_SDA/TIN1
N13	GPIO053/PWM0/SLV_SPI_MSTR_INT/GPWM0
L11	GPIO054/PWM1/SLV_SPI_SCLK/GPWM1
N14	GPIO027/KSI4/I2C12_SCL/TIN2
L12	GPIO030/KSI5/I2C10_SDA/TIN3
L13	GPIO107/nSMI/KSO04/I2C10_SCL
M12	GPIO120/KSO07/UART1_DTR#
K11	GPIO112/KSO05(DSW_PWRGD)
M14	GPIO113/KSO06/ICT9
K10	GPIO114/PS2_CLK0A/nEC_SCI
K12	GPIO042/PECI_DAT/SB-TSI_DAT
K13	GPIO043/SB-TSI_CLK
H14	GPIO044/VREF_VTT
K14	GPIO034/RC_ID1/SPI0_CLK
J12	GPIO036/RC_ID2/SPI0_MISO
D14	GPIO035/PWM8/CTOUT1/ICT15/LED3
J9	GPIO170/UART1_TX/TFDP_CLK[JTAG_STRAP]
H13	GPIO171/UART1_RX/TFDP_DATA
H9	JTAG_RST#
C13	GPIO104/UART0_TX
G14	GPIO105/UART0_RX
G10	GPIO046/KSO02/ICT11/BCM1_DAT
D12	GPIO047/KSO03/PWM3_ALT/ICT13/BCM1_CLK
H12	GPIO121/PVT_IO0/KSO08
F12	GPIO122/PVT_IO1/KSO09
G13	GPIO123/PVT_IO2/KSO10
E13	GPIO126/PVT_IO3/KSO13[UART_BSTRAP]
G12	GPIO124/PVT_CS#/KSO11/ICT12/GPTP_OUT6
E12	GPIO125/PVT_CLK/GPTP_OUT5
F10	GPIO175/KSO17_ALT/PWM8_ALT
C12	GPIO127/A20M/UART1_RTS#/UART0_CTS#_ALT
E11	GPIO156/LED0
D10	GPIO157/LED1
D11	GPIO153/LED2
C10	GPIO007/I2C03_SDA/PS2_CLK0B
E8	GPIO010/I2C03_SCL/PS2_DAT0B
E9	GPIO154/I2C02_SDA/CPU_C10
C9	GPIO155/I2C02_SCL(SYSPWR_VALID)

TABLE 2-1: MEC1725 176 WFBGA PINOUT

Pin Map	Signal
A8	GPIO045/KSO01/PWM2_ALT/ICT14[CR_STRAP]
C8	GPIO165/32KHZ_IN/CTOUT0
B6	GPIO145/I2C09_SDA/JM_TDI
E7	GPIO146/I2C09_SCL/JM_TDO
B8	GPIO147/I2C15_SDA/JM_TCLK
C7	GPIO150/I2C15_SCL/JM_TMS
A5	GPIO141/I2C05_SDA/SPI1_CLK/UART0_DCD#_ALT
B5	GPIO142/I2C05_SCL/SPI1_MOSI/UART0_DSR#_ALT
C5	GPIO143/I2C04_SDA/SPI1_MISO/UART0_DTR#_ALT
C6	GPIO144/I2C04_SCL/SPI1_CS#/UART0_RI#_ALT
B3	GPIO004/I2C00_SCL/SPI0_MOSI
C4	GPIO003/I2C00_SDA/SPI0_CS0#
A7	VCI_IN1#/GPIO162
A6	VCI_IN0#
D5	BGPO0
C3	BGPO1/GPIO101
J10	BGPO2/GPIO102
J13	BGPO3/GPIO172
A4	XTAL1
A2	XTAL2
E4	VCI_IN2#/GPIO161
F14	GPIO117
H3	GPIO210/ADC08
G2	GPIO211/ADC09
J2	GPIO212/ADC10
H2	GPIO213/ADC11
H1	GPIO214/ADC12
K1	GPIO215/ADC13
L2	GPIO216/ADC14
K5	GPIO217/ADC15
C11	GPIO133/PWM9
C14	GPIO134/PWM10/UART1_RTS#_ALT
N9	GPIO001/PWM4_ALT
D4	SYSPWR_PRES
B4	GPIO006/I2C11_SCL_ALT/GPTP_OUT7
A1	GPIO166/PWRGD_S0iX_ALT
B7	VCI_OVRD_IN
A3	GPIO005/I2C11_SDA_ALT/GPTP_OUT4
E1	GPIO041/EMC_SYS_SHDN#
E10	GPIO225/UART0_RTS#_ALT
H10	GPIO135/UART1_CTS#_ALT
G9	GPIO103 (THERMTRIP2#)
D13	GPIO160/PWM11/PROCHOT_IN#/PROCHOT_IO#
P7	GPIO233

MEC1725

TABLE 2-1: MEC1725 176 WFBGA PINOUT

Pin Map	Signal
M13	GPIO111
K9	GPIO231/I2C08_SDA
L14	GPIO110
M8	GPIO230/I2C08_SCL
E6	VCI_OUT1
F13	GPIO074
J14	GPIO075
E14	GPIO076
B13	THERMTRIP1#
A9	DP1_DN1A
B9	DN1_DP1A
A12	DP2_DN2A
B12	DN2_DP2A
A10	DP4_DN4A
B10	DN4_DP4A
A11	DP3_DN3A
B11	DN3_DP3A
B14	VCP
A13	VSET
A14	VIN
F8	VSS_ANALOG
D1	VTR_PLL
F5	VBAT
G6	VSS
H5	VTR_REG
J3	VREF_ADC
K3	VSS_ADC
J7	VSS
F6	VTR1
F9	VTR_ANALOG
G1	VR_CAP
F7	VSS
J8	VTR2
J6	VTR3
H6	VSS

Note: GPIO103 is a dedicated connection to the Thermtrip2# Environment Monitor block and users should exercise caution in modifying default settings.

2.4 Pin Multiplexing

2.4.1 DEFAULT STATE

The default state for analog pins is Input. The default state for all pins that default to a GPIO function is input/output/interrupt disabled. The default state for pins that differ is shown in the [Table 3-4, "GPIO Pin Control Default Values"](#).

2.4.2 POWER RAIL

The Power Rail column defines the power pin that provides I/O power for the signal pin.

2.4.3 BUFFER TYPES

The Buffer Type column defines the type of Buffer associated with each signal. Some pins have signals with two different buffer types sharing the pin; in this case, table shows the buffer type for each of the signals that share the pin.

Input signals muxed with GPIOs are marked as "I"

Output signals muxed with GPIOs are marked as "O", But the GPIO input path is always active even when the alternate function selected is "output only". So the GPIO input can be read to see the level of the output signal.

Pad Types are defined in the [Section 52.0, "Electrical Specifications"](#).

- I/O Pad Types are defined in [Section 52.2.4, "DC Electrical Characteristics for I/O Buffers"](#).
- The abbreviation "PWR" is used to denote power pins. The power supplies are defined in [Section 52.2.1, "Power Supply Operational Characteristics"](#).

2.4.4 GLITCH PROTECTION

Pins with glitch protection are glitch-free tristate pins and will not drive out while their associated power rail is rising. These glitch-free tristate pins require either an external pull-up or pull-down to set the state of the pin high or low.

Note: If the pin needs to default low, a 1M ohm (max) external pull-down is required.

All pins are glitch protected.

Note: The power rail must rise monotonically in order for glitch protection to operate.

2.4.5 OVER-VOLTAGE PROTECTION (OVP)

If a pin is over-voltage protected (over-voltage protection = YES) then the following is true: If the pad is powered by 1.8V +/- 5% (operational) it can tolerate up to 3.63V on the pad. This allows for a pull-up to 3.3V power rail +/- 10%. If the pad is powered by 3.3V +/- 5% (operational) it can tolerate up to 5.5V on the pad. This allows for a pull-up to 5.0V power rail +/- 10%.

If a pin is not over-voltage protected (over-voltage protection = NO) then the following is true: If the pad is powered by 1.8V +/- 5% (operational), it can tolerate up to 1.8V +10% (i.e., +1.98V max). If the pad is powered by 3.3V +/- 5% (operational) it can tolerate up to 3.3V +10% (i.e., +3.63V max).

2.4.6 UNDER-VOLTAGE PROTECTION

Pins that are identified as having Under-voltage PROTECTION may be configured so they will not sink excess current if powered by 3.3V and externally pulled up to 1.8V. The following configuration requirements must be met.

- If the pad is an output only pad type and it is configured as either open drain or the output is disabled.
- If the pin is a GPIO pin with a PIO pad type then it must be configured as open drain output with the input disabled. The input is disabled by setting the GPIO [Power Gating Signals \(PGS\)](#) bits to 11b.

All pins are under voltage protected.

2.4.7 BACKDRIVE PROTECTION (BDP)

Assuming that the external voltage on the pin is within the parameters defined for the specific pad type, the backdrive protected pin will not sink excess current when it is at a lower potential than the external circuit. There are two cases where this occurs:

- The pad power is off and the external circuit is powered
- The pad power is on and the external circuitry is pulled to a higher potential than the pad power. This may occur on 3.3V powered pads that are 5V tolerant or on 1.8V powered pads that are 3.6V tolerant.

2.4.8 EMULATED POWER WELL

Power well emulation for GPIOs and for signals that are multiplexed with GPIO signals is controlled by the [Power Gating Signals \(PGS\)](#) option in the [GPIO Pin Control Register](#). The Emulated Power Well column in the Pin Multiplexing table defines the power gating programming options supported for each signal.

MEC1725

Note: VBAT powered signals do not support power emulation and must program the PGS bit field to 00b (VTR)

2.4.9 GATED STATE

This column defines the internal value of an input signal when either its emulated power well is inactive or it is not selected by the GPIO alternate function MUX. A value of “No Gate” means that the internal signal always follows the pin even when the emulated power well is inactive.

Note: Gated state is only meaningful to the operation of input signals. A gated state on an output pin defines the internal behavior of the GPIO MUX and does not imply pin behavior.

Note: Only the pins that are 5V tolerant have an entry in the 5VT column in the Pin Description Table.

2.4.10 PIN MULTIPLEXING

TABLE 2-2: MEC1725 176 WFBGA PIN MUX TABLE

Mux value	Signal Name	Buffer type	Drive Strength	PAD Power Well	Emulated Power Well	Gated State	OVP	BDP	Notes
Default:0	GPIO000	PIO		VBAT	All PGS options	No Gate	No	Yes	
1	VCI_IN3#	I			PGS=00 (only)	No Gate			
2	Reserved								
3	Reserved								
4	Reserved								
5	Reserved								
Default:0	GPIO033	PIO		VTR1	All PGS options	No Gate	No	Yes	
1	TACH3	I			All PGS options	Low			
2	RC_ID0	PIO			PGS=00 (only)	Low			
3	Reserved								
4	Reserved								
5	Reserved								
Default:0	GPIO022	PIO		VTR1	All PGS options	No Gate	No	Yes	
1	Reserved								
2	Reserved								
3	GPTP_IN4	I			All PGS options	Low			
4	32kHz_OUT_ALT	O			All PGS options	NA			
5	Reserved								
Default:0	GPIO023	PIO		VTR1	All PGS options	No Gate	No	Yes	
1	Reserved								

TABLE 2-2: MEC1725 176 WFBGA PIN MUX TABLE

Mux value	Signal Name	Buffer type	Drive Strength	PAD Power Well	Emulated Power Well	Gated State	OVP	BDP	Notes
2	GPTP_IN7	I			All PGS options	Low			
3	Reserved								
4	Reserved								
5	Reserved								
Default:0	GPIO024 (nRESET_IN)	PIO		VTR1	All PGS options	No Gate	No	Yes	
1	Reserved								
2	Reserved								
3	Reserved								
4	Reserved								
5	Reserved								
Default:0	GPIO221	PIO		VTR1	All PGS options	No Gate	No	No	
1	32KHz_OUT	O			All PGS options	NA			
2	GPTP_IN3	I			All PGS options	Low			
3	Reserved								
4	Reserved								
5	Reserved								
Default:0	GPIO057	PIO		VTR1	All PGS options	No Gate	No	No	
1	VCC_PWRGD	I			PGS=00 (only)	High			
2	Reserved								
3	Reserved								
4	Reserved								
5	Reserved								
Default:0	GPIO106	PIO		VTR1	All PGS options	No Gate	No	No	
1	PWROK	O			PGS=00 (only)	No Gate			
2	Reserved								
3	Reserved								
4	Reserved								
5	Reserved								
Default:0	GPIO226	PIO		VTR1	All PGS options	No Gate	No	No	
1	Reserved								
2	PWRGD_S0iX	I			PGS=00 (only)	High			
3	Reserved								
4	Reserved								
5	Reserved								

MEC1725

TABLE 2-2: MEC1725 176 WFBGA PIN MUX TABLE

Mux value	Signal Name	Buffer type	Drive Strength	PAD Power Well	Emulated Power Well	Gated State	OVP	BDP	Notes
Default:0	GPIO060	PIO		VTR1	All PGS options	No Gate	No	Yes	
1	KBRST	O			All PGS options	NA			
2	TST_CLK_OUT	O			All PGS options	NA			
3	UART1_DCD#	I			All PGS options	High			
4	SPI0_CS1#	O			All PGS options	NA			
5	Reserved								
Default:0	GPIO051	PIO		VTR1	All PGS options	No Gate	Yes	Yes	The Over voltage protected GPIO pins will not support the Repeater mode mentioned in the GPIO pin configuration
1	ICT1_TACH1	I			All PGS options	Low			
2	GTACH1	I			All PGS options	Low			
3	Reserved								
4	Reserved								
5	Reserved								
Default:0	GPIO050	PIO		VTR1	All PGS options	No Gate	Yes	Yes	The Over voltage protected GPIO pins will not support the Repeater mode mentioned in the GPIO pin configuration
1	ICT0_TACH0	I			All PGS options	Low			
2	GTACH0	I			All PGS options	Low			
3	Reserved								
4	Reserved								
5	Reserved								
Default:0	GPIO200	PIO		VTR1	All PGS options	No Gate	No	No	
1	ADC00	I_AN			PGS=00 (only)	Low			
2	Reserved								
3	Reserved								
4	Reserved								
5	Reserved								
Default:0	GPIO201	PIO		VTR1	All PGS options	No Gate	No	No	

TABLE 2-2: MEC1725 176 WFBGA PIN MUX TABLE

Mux value	Signal Name	Buffer type	Drive Strength	PAD Power Well	Emulated Power Well	Gated State	OVP	BDP	Notes
1	ADC01	I_AN			PGS=00 (only)	Low			
2	Reserved								
3	Reserved								
4	Reserved								
5	Reserved								
Default:0	GPIO202	PIO		VTR1	All PGS options	No Gate	No	No	
1	ADC02	I_AN			PGS=00 (only)	Low			
2	Reserved								
3	Reserved								
4	Reserved								
5	Reserved								
Default:0	GPIO203	PIO		VTR1	All PGS options	No Gate	No	No	
1	ADC03	I_AN			PGS=00 (only)	Low			
2	Reserved								
3	Reserved								
4	Reserved								
5	Reserved								
Default:0	GPIO204	PIO		VTR1	All PGS options	No Gate	No	No	
1	ADC04	I_AN			PGS=00 (only)	Low			
2	Reserved								
3	Reserved								
4	Reserved								
5	Reserved								
Default:0	GPIO205	PIO		VTR1	All PGS options	No Gate	No	No	
1	ADC05	I_AN			PGS=00 (only)	Low			
2	Reserved								
3	Reserved								
4	Reserved								
5	Reserved								
Default:0	GPIO206	PIO		VTR1	All PGS options	No Gate	No	No	
1	ADC06	I_AN			PGS=00 (only)	Low			
2	Reserved								
3	Reserved								
4	Reserved								

MEC1725

TABLE 2-2: MEC1725 176 WFBGA PIN MUX TABLE

Mux value	Signal Name	Buffer type	Drive Strength	PAD Power Well	Emulated Power Well	Gated State	OVP	BDP	Notes
5	Reserved								
Default:0	GPIO207	PIO		VTR1	All PGS options	No Gate	No	No	
1	ADC07	I_AN			PGS=00 (only)	Low			
2	Reserved								
3	Reserved								
4	Reserved								
5	Reserved								
Default:0	GPIO064	PIO		VTR1	All PGS options	No Gate	No	No	
1	SLP_S0#	I			PGS=00 (only)	High			
2	Reserved								
3	Reserved								
4	Reserved								
5	Reserved								
Default:0	GPIO067	PIO		VTR1	All PGS options	No Gate	No	Yes	
1	VREF2_ADC	O			PGS=00 (only)	Low			GPIO067/VREF2_A DC used as a GPIO can inject noise into the ADC. Hence care should be taken in system
2	Reserved								
3	Reserved								
4	Reserved								
5	Reserved								
Default:0	GPIO066	PIO	24mA	VTR3	All PGS options	No Gate	No	No	Drive strength can be configured by Pin Control register2 to 4,8,16 or 24mA
1	ESPI_CS#	I			PGS=00 (only)	High			
2	I2C13_SDA	PIO			All PGS options	High			When used as an I2C port, this is a 1.8V I2C port and external pull up should be to 1.8V
3	Reserved								
4	Reserved								
5	Reserved								
Default:0	GPIO061	PIO		VTR3	All PGS options	No Gate	No	Yes	

TABLE 2-2: MEC1725 176 WFBGA PIN MUX TABLE

Mux value	Signal Name	Buffer type	Drive Strength	PAD Power Well	Emulated Power Well	Gated State	OVP	BDP	Notes
1	ESPI_RESET#	I			PGS=00 (only)	High			
2	Reserved								
3	Reserved								
4	Reserved								
5	Reserved								
Default:0	GPIO065	PIO	24mA	VTR3	All PGS options	No Gate	No	No	Drive strength can be configured by Pin Control register2 to 4,8,16 or 24mA
1	ESPI_CLK	I			PGS=00 (only)	Low			
2	I2C13_SCL	PIO			All PGS options	High			When used as an I2C port, this is a 1.8V I2C port and external pull up should be to 1.8V
3	ICT5_ALT	I			All PGS options	Low			
4	Reserved								
5	Reserved								
Default:0	GPIO070	PIO	24mA	VTR3	All PGS options	No Gate	No	No	Drive strength can be configured by Pin Control register2 to 4,8,16 or 24mA
1	ESPI_IO0	PIO			PGS=00 (only)	Low			
2	I2C14_SDA	PIO			All PGS options	High			When used as an I2C port, this is a 1.8V I2C port and external pull up should be to 1.8V
3	Reserved								
4	Reserved								
5	Reserved								
Default:0	GPIO071	PIO	24mA	VTR3	All PGS options	No Gate	No	No	Drive strength can be configured by Pin Control register2 to 4,8,16 or 24mA
1	ESPI_IO1	PIO			PGS=00 (only)	Low			
2	I2C14_SCL	PIO			All PGS options	High			When used as an I2C port, this is a 1.8V I2C port and external pull up should be to 1.8V
3	Reserved								
4	Reserved								

MEC1725

TABLE 2-2: MEC1725 176 WFBGA PIN MUX TABLE

Mux value	Signal Name	Buffer type	Drive Strength	PAD Power Well	Emulated Power Well	Gated State	OVP	BDP	Notes
5	Reserved								
Default:0	GPIO072	PIO	24mA	VTR3	All PGS options	No Gate	No	No	Drive strength can be configured by Pin Control register2 to 4,8,16 or 24mA
1	ESPI_IO2	PIO			PGS=00 (only)	Low			
2	I2C01_SDA_ALT	PIO			All PGS options	High			When used as an I2C port, this is a 1.8V I2C port and external pull up should be to 1.8V
3	Reserved								
4	Reserved								
5	Reserved								
Default:0	GPIO073	PIO	24mA	VTR3	All PGS options	No Gate	No	No	Drive strength can be configured by Pin Control register2 to 4,8,16 or 24mA
1	ESPI_IO3	PIO			PGS=00 (only)	Low			
2	I2C01_SCL_ALT	PIO			All PGS options	High			When used as an I2C port, this is a 1.8V I2C port and external pull up should be to 1.8V
3	Reserved								
4	Reserved								
5	Reserved								
Default:0	GPIO100	PIO		VTR3	All PGS options	No Gate	No	Yes	
1	nEC_SCI_ALT	O			All PGS options	NA			
2	ICT6	I			All PGS options	Low			
3	Reserved								
4	Reserved								
5	Reserved								
Default:0	GPIO011	PIO		VTR3	All PGS options	No Gate	No	Yes	
1	nSMI_ALT	O			All PGS options	NA			
2	PWM4	O			All PGS options	NA			
3	ICT7	I			All PGS options	Low			
4	Reserved								
5	Reserved								

TABLE 2-2: MEC1725 176 WFBGA PIN MUX TABLE

Mux value	Signal Name	Buffer type	Drive Strength	PAD Power Well	Emulated Power Well	Gated State	OVP	BDP	Notes
Default:0	GPIO063	PIO		VTR3	All PGS options	No Gate	No	Yes	
1	ESPI_ALERT#	O			PGS=00 (only)	NA			
2	PWM6_ALT	O			All PGS options	NA			
3	ICT8	I			All PGS options	Low			
4	Reserved								
5	Reserved								
Default:0	GPIO222	PIO		VTR2	All PGS options	No Gate	No	Yes	
1	Reserved								
2	PRO-CHOT_IN#_ALT	I			All PGS options	High			
3	Reserved								
4	Reserved								
5	Reserved								
Default:0	GPIO224	PIO	24mA	VTR2	All PGS options	No Gate	No	Yes	Drive strength can be configured by Pin Control register2 to 4,8,16 or 24mA
1	GPTP_IN0	I			All PGS options	Low			
2	SHD_IO1	PIO			All PGS options	Low			
3	Reserved								
4	Reserved								
5	Reserved								
Default:0	GPIO016	PIO	24mA	VTR2	All PGS options	No Gate	No	Yes	Drive strength can be configured by Pin Control register2 to 4,8,16 or 24mA
1	GPTP_IN1	I			All PGS options	Low			
2	SHD_IO3	PIO			All PGS options	Low			
3	ICT3	I			All PGS options	Low			
4	Reserved								
5	Reserved								
Default:0	GPIO227	PIO	24mA	VTR2	All PGS options	No Gate	No	Yes	Drive strength can be configured by Pin Control register2 to 4,8,16 or 24mA
1	SHD_IO2	PIO			All PGS options	Low			

MEC1725

TABLE 2-2: MEC1725 176 WFBGA PIN MUX TABLE

Mux value	Signal Name	Buffer type	Drive Strength	PAD Power Well	Emulated Power Well	Gated State	OVP	BDP	Notes
2	Reserved								
3	Reserved								
4	Reserved								
5	Reserved								
Default:0	GPIO223	PIO	24mA	VTR2	All PGS options	No Gate	No	Yes	Drive strength can be configured by Pin Control register2 to 4,8,16 or 24mA
1	SHD_IO0	PIO			All PGS options	Low			
2	Reserved								
3	Reserved								
4	Reserved								
5	Reserved								
Default:0	GPIO055	PIO		VTR2	All PGS options	No Gate	No	Yes	
1	PWM2	O			All PGS options	NA			
2	SHD_CS0#	O			All PGS options	NA			
3	Reserved								
4	Reserved								
5	Reserved								
Default:0	GPIO056	PIO	24mA	VTR2	All PGS options	No Gate	No	Yes	Drive strength can be configured by Pin Control register2 to 4,8,16 or 24mA
1	PWM3	O			All PGS options	NA			
2	SHD_CLK	O			All PGS options	NA			
3	Reserved								
4	Reserved								
5	Reserved								
Default:0	GPIO012	PIO		VTR2	All PGS options	No Gate	No	Yes	
1	I2C07_SDA	PIO			All PGS options	High			
2	SLV_SPI_IO2	PIO			All PGS options	Low			
3	TOUT3	O			All PGS options	NA			
4	Reserved								
5	Reserved								
Default:0	GPIO013	PIO		VTR2	All PGS options	No Gate	No	Yes	

TABLE 2-2: MEC1725 176 WFBGA PIN MUX TABLE

Mux value	Signal Name	Buffer type	Drive Strength	PAD Power Well	Emulated Power Well	Gated State	OVP	BDP	Notes
1	I2C07_SCL	PIO			All PGS options	High			
2	SLV_SPI_IO3	PIO			All PGS options	Low			
3	TOUT2	O			All PGS options	NA			
4	Reserved								
5	Reserved								
Default:0	GPIO130	PIO		VTR2	All PGS options	No Gate	No	Yes	
1	I2C01_SDA	PIO			All PGS options	High			
2	SLV_SPI_IO0	PIO			All PGS options	Low			
3	TOUT1	O			All PGS options	NA			
4	Reserved								
5	Reserved								
Default:0	GPIO131	PIO		VTR2	All PGS options	No Gate	No	Yes	
1	I2C01_SCL	PIO			All PGS options	High			
2	SLV_SPI_CS#	I			All PGS options	High			
3	TOUT0	O			All PGS options	NA			
4	Reserved								
5	Reserved								
Default:0	GPIO020	PIO		VTR1	All PGS options	No Gate	No	Yes	
1	KSI1	I			All PGS options	Low			
2	Reserved								
3	Reserved								
4	Reserved								
5	Reserved								
Default:0	GPIO021	PIO		VTR1	All PGS options	No Gate	No	Yes	
1	KSI2	I			All PGS options	Low			
2	Reserved								
3	Reserved								
4	Reserved								
5	Reserved								
Default:0	GPIO052	PIO		VTR2	All PGS options	No Gate	No	Yes	

MEC1725

TABLE 2-2: MEC1725 176 WFBGA PIN MUX TABLE

Mux value	Signal Name	Buffer type	Drive Strength	PAD Power Well	Emulated Power Well	Gated State	OVP	BDP	Notes
1	ICT2_TACH2	I			All PGS options	Low			
2	Reserved								
3	Reserved								
4	Reserved								
5	Reserved								
Default:0	GPIO002	PIO		VTR2	All PGS options	No Gate	No	Yes	
1	PWM5	O			All PGS options	NA			
2	SHD_CS1#	O			All PGS options	NA			
3	Reserved								
4	Reserved								
5	Reserved								
Default:0	GPIO014	PIO		VTR2	All PGS options	No Gate	No	Yes	
1	PWM6	O			All PGS options	NA			
2	SLV_SPI_IO1	PIO			All PGS options	Low			
3	GPTP_IN2	I			All PGS options	Low			
4	Reserved								
5	Reserved								
Default:0	GPIO015	PIO		VTR2	All PGS options	No Gate	No	Yes	
1	PWM7	O			All PGS options	NA			
2	ICT10	I			All PGS options	Low			
3	Reserved								
4	Reserved								
5	Reserved								
Default:0	GPIO151	PIO		VTR1	All PGS options	No Gate	No	Yes	
1	ICT4	I			All PGS options	Low			
2	KSO15	O			All PGS options	NA			
3	Reserved								
4	Reserved								
5	Reserved								
Default:0	GPIO152	PIO		VTR1	All PGS options	No Gate	No	Yes	

TABLE 2-2: MEC1725 176 WFBGA PIN MUX TABLE

Mux value	Signal Name	Buffer type	Drive Strength	PAD Power Well	Emulated Power Well	Gated State	OVP	BDP	Notes
1	KSO14	O			All PGS options	NA			
2	GPTP_OUT3	O			All PGS options	NA			
3	Reserved								
4	Reserved								
5	Reserved								
Default:0	GPIO017	PIO		VTR1	All PGS options	No Gate	No	Yes	
1	KSI0	I			All PGS options	Low			
2	UART0_DCD#	I			All PGS options	NA			
3	GPTP_IN5	I			All PGS options	Low			
4	Reserved								
5	Reserved								
Default:0	GPIO040	PIO		VTR1	All PGS options	No Gate	No	Yes	
1	GPTP_OUT2	O			All PGS options	NA			
2	KSO00	O			All PGS options	NA			
3	Reserved								
4	Reserved								
5	Reserved								
Default:0	GPIO032	PIO		VTR1	All PGS options	No Gate	No	Yes	
1	KSI7	I			All PGS options	Low			
2	GPTP_OUT0	O			All PGS options	NA			
3	UART0_RI#	I			All PGS options	High			
4	Reserved								
5	Reserved								
Default:0	GPIO031	PIO		VTR1	All PGS options	No Gate	No	Yes	
1	KSI6	I			All PGS options	Low			
2	GPTP_OUT1	O			All PGS options	NA			
3	Reserved								
4	Reserved								
5	Reserved								

MEC1725

TABLE 2-2: MEC1725 176 WFBGA PIN MUX TABLE

Mux value	Signal Name	Buffer type	Drive Strength	PAD Power Well	Emulated Power Well	Gated State	OVP	BDP	Notes
Default:0	GPIO132	PIO		VTR1	All PGS options	No Gate	No	Yes	
1	I2C06_SDA	PIO			All PGS options	High			
2	KSO16	O			All PGS options	NA			
3	Reserved								
4	Reserved								
5	Reserved								
Default:0	GPIO140	PIO		VTR1	All PGS options	No Gate	No	Yes	
1	I2C06_SCL	PIO			All PGS options	High			
2	ICT5	I			All PGS options	Low			
3	KSO17	O			All PGS options	NA			
4	Reserved								
5	Reserved								
Default:0	GPIO115	PIO		VTR1	All PGS options	No Gate	Yes	Yes	The Over voltage protected GPIO pins will not support the Repeater mode mentioned in the GPIO pin configuration
1	PS2_DAT0A	PIO			All PGS options	Low			
2	Reserved								
3	Reserved								
4	Reserved								
5	Reserved								
Default:0	GPIO025	PIO		VTR1	All PGS options	No Gate	No	Yes	
1	nEMI_INT	O			All PGS options	NA			
2	UART_CLK	I			All PGS options	Low			
3	UART1_RI#	I			All PGS options	High			
4	TIN0	I			All PGS options	Low			
5	Reserved								
Default:0	GPIO026	PIO		VTR1	All PGS options	No Gate	No	Yes	
1	KSI3	I			All PGS options	Low			
2	Reserved								

TABLE 2-2: MEC1725 176 WFBGA PIN MUX TABLE

Mux value	Signal Name	Buffer type	Drive Strength	PAD Power Well	Emulated Power Well	Gated State	OVP	BDP	Notes
3	I2C12_SDA	PIO			All PGS options	High			
4	TIN1	I			All PGS options	Low			
5	Reserved								
Default:0	GPIO053	PIO		VTR2	All PGS options	No Gate	Yes	Yes	The Over voltage protected GPIO pins will not support the Repeater mode mentioned in the GPIO pin configuration
1	PWM0	O			All PGS options	NA			
2	SLV_SPI_M-STR_INT	O			All PGS options	NA			
3	PWM0	O			All PGS options	NA			
4	Reserved								
5	Reserved								
Default:0	GPIO054	PIO		VTR2	All PGS options	No Gate	Yes	Yes	The Over voltage protected GPIO pins will not support the Repeater mode mentioned in the GPIO pin configuration
1	PWM1	O			All PGS options	Low			
2	SLV_SPI_SCLK	I			All PGS options	Low			
3	PWM1	O			All PGS options	Low			
4	Reserved								
5	Reserved								
Default:0	GPIO027	PIO		VTR1	All PGS options	No Gate	No	Yes	
1	KSI4	I			All PGS options	Low			
2	Reserved								
3	I2C12_SCL	PIO			All PGS options	High			
4	TIN2	I			All PGS options	Low			
5	Reserved								
Default:0	GPIO030	PIO		VTR1	All PGS options	No Gate	No	Yes	
1	KSI5	I			All PGS options	Low			

MEC1725

TABLE 2-2: MEC1725 176 WFBGA PIN MUX TABLE

Mux value	Signal Name	Buffer type	Drive Strength	PAD Power Well	Emulated Power Well	Gated State	OVP	BDP	Notes
2	I2C10_SDA	PIO			All PGS options	High			
3	TIN3	I			All PGS options	Low			
4	Reserved								
5	Reserved								
Default:0	GPIO107	PIO		VTR1	All PGS options	No Gate	No	Yes	
1	nSMI	O			All PGS options	NA			
2	KSO04	O			All PGS options	NA			
3	I2C10_SCL	PIO			All PGS options	High			
4	Reserved								
5	Reserved								
Default:0	GPIO120	PIO		VTR1	All PGS options	No Gate	No	Yes	
1	KSO07	O			All PGS options	NA			
2	UART1_DTR#	O			All PGS options	NA			
3	Reserved								
4	Reserved								
5	Reserved								
Default:0	GPIO112	PIO		VTR1	All PGS options	No Gate	No	Yes	
1	KSO05	O			All PGS options	NA			
2	Reserved								
3	Reserved								
4	Reserved								
5	Reserved								
Default:0	GPIO113	PIO		VTR1	All PGS options	No Gate	No	Yes	
1	KSO06	O			All PGS options	NA			
2	ICT9	I			All PGS options	Low			
3	Reserved								
4	Reserved								
5	Reserved								

TABLE 2-2: MEC1725 176 WFBGA PIN MUX TABLE

Mux value	Signal Name	Buffer type	Drive Strength	PAD Power Well	Emulated Power Well	Gated State	OVP	BDP	Notes
Default:0	GPIO114	PIO		VTR1	All PGS options	No Gate	Yes	Yes	The Over voltage protected GPIO pins will not support the Repeater mode mentioned in the GPIO pin configuration
1	PS2_CLK0A	PIO			All PGS options	Low			
2	nEC_SCI	O			All PGS options	NA			
3	Reserved								
4	Reserved								
5	Reserved								
Default:0	GPIO042	PIO		VTR1	All PGS options	No Gate	No	No	
1	PECI_DAT	PECI_IO			All PGS options	Low			
2	SB-TSI_DAT	SB-TSI			All PGS options	High			SB-TSI port is mapped to I2C/SMB Port 10. (port_sel[3:0] = 1010)
3	Reserved								
4	Reserved								
5	Reserved								
Default:0	GPIO043	PIO		VTR1	All PGS options	No Gate	No	No	
1	SB-TSI_CLK	SB-TSI			All PGS options	High			SB-TSI port is mapped to I2C/SMB Port 10. (port_sel[3:0] = 1010)
2	Reserved								
3	Reserved								
4	Reserved								
5	Reserved								
Default:0	GPIO044	PIO		VTR1	All PGS options	No Gate	No	No	
1	VREF_VTT	VREF_VTT			All PGS options	Low			
2	Reserved								
3	Reserved								
4	Reserved								
5	Reserved								
Default:0	GPIO034	PIO		VTR1	All PGS options	No Gate	No	No	
1	Reserved								
2	RC_ID1	PIO			PGS=00 (only)	Low			

MEC1725

TABLE 2-2: MEC1725 176 WFBGA PIN MUX TABLE

Mux value	Signal Name	Buffer type	Drive Strength	PAD Power Well	Emulated Power Well	Gated State	OVP	BDP	Notes
3	Reserved								
4	SPIO_CLK	O			All PGS options	NA			
5	Reserved								
Default:0	GPIO036	PIO		VTR1	All PGS options	No Gate	No	No	
1	Reserved								
2	RC_ID2	PIO			PGS=00 (only)	Low			
3	SPIO_MISO	I			All PGS options	Low			
4	Reserved								
5	Reserved								
Default:0	GPIO035	PIO		VTR1	All PGS options	No Gate	Yes	Yes	The Over voltage protected GPIO pins will not support the Repeater mode mentioned in the GPIO pin configuration
1	PWM8	O			All PGS options	NA			
2	CTOUT1	O			All PGS options	NA			
3	ICT15	I			All PGS options	Low			
4	LED3	O			All PGS options	NA			
5	Reserved								
Default:0	GPIO170	PIO	PU	VTR1	All PGS options	No Gate	No	Yes	
1	UART1_TX	O			All PGS options	NA			
2	TFDP_CLK	O			All PGS options	NA			
3	Reserved								
4	Reserved								
5	Reserved								
Default:0	GPIO171	PIO		VTR1	All PGS options	No Gate	No	Yes	
1	UART1_RX	I			All PGS options	Low			
2	TFDP_DATA	O			All PGS options	NA			
3	Reserved								
4	Reserved								
5	Reserved								
NA	JTAG_RST#	I		VTR1	NA	NA	No	Yes	

TABLE 2-2: MEC1725 176 WFBGA PIN MUX TABLE

Mux value	Signal Name	Buffer type	Drive Strength	PAD Power Well	Emulated Power Well	Gated State	OVP	BDP	Notes
Default:0	GPIO104	PIO		VTR1	All PGS options	No Gate	No	Yes	
1	UART0_TX	O			All PGS options	NA			
2	Reserved								
3	Reserved								
4	Reserved								
5	Reserved								
Default:0	GPIO105	PIO		VTR1	All PGS options	No Gate	No	Yes	
1	UART0_RX	I			All PGS options	Low			
2	Reserved								
3	Reserved								
4	Reserved								
5	Reserved								
Default:0	GPIO046	PIO		VTR1	All PGS options	No Gate	No	Yes	
1	KSO02	O			All PGS options	NA			
2	ICT11	I			All PGS options	Low			
3	Reserved								
4	BCM1_DAT	PIO			All PGS options	Low			
5	Reserved								
Default:0	GPIO047	PIO		VTR1	All PGS options	No Gate	No	Yes	
1	KSO03	O			All PGS options	NA			
2	PWM3_ALT	O			All PGS options	NA			
3	ICT13	I			All PGS options	Low			
4	BCM1_CLK	O			All PGS options	NA			
5	Reserved								
Default:0	GPIO121	PIO		VTR1	All PGS options	No Gate	No	Yes	
1	PVT_IO0	PIO			All PGS options	Low			
2	KSO08	O			All PGS options	NA			
3	Reserved								
4	Reserved								
5	Reserved								

MEC1725

TABLE 2-2: MEC1725 176 WFBGA PIN MUX TABLE

Mux value	Signal Name	Buffer type	Drive Strength	PAD Power Well	Emulated Power Well	Gated State	OVP	BDP	Notes
Default:0	GPIO122	PIO		VTR1	All PGS options	No Gate	No	Yes	
1	PVT_IO1	PIO			All PGS options	Low			
2	KSO09	O			All PGS options	NA			
3	Reserved								
4	Reserved								
5	Reserved								
Default:0	GPIO123	PIO		VTR1	All PGS options	No Gate	No	Yes	
1	PVT_IO2	PIO			All PGS options	Low			
2	KSO10	O			All PGS options	NA			
3	Reserved								
4	Reserved								
5	Reserved								
Default:0	GPIO126	PIO		VTR1	All PGS options	No Gate	No	Yes	
1	PVT_IO3	PIO			All PGS options	Low			
2	KSO13	O			All PGS options	NA			
3	Reserved								
4	Reserved								
5	Reserved								
Default:0	GPIO124	PIO		VTR1	All PGS options	No Gate	No	Yes	
1	PVT_CS#	O			All PGS options	NA			
2	KSO11	O			All PGS options	NA			
3	ICT12	I			All PGS options	Low			
4	GPTP_OUT6	O			All PGS options	NA			
5	Reserved								
Default:0	GPIO125	PIO		VTR1	All PGS options	No Gate	No	Yes	
1	PVT_CLK	O			All PGS options	NA			
2	KSO12	O			All PGS options	NA			
3	GPTP_OUT5	O			All PGS options	NA			
4	Reserved								

TABLE 2-2: MEC1725 176 WFBGA PIN MUX TABLE

Mux value	Signal Name	Buffer type	Drive Strength	PAD Power Well	Emulated Power Well	Gated State	OVP	BDP	Notes
5	Reserved								
Default:0	GPIO175	PIO		VTR1	All PGS options	No Gate	No	Yes	
1	Reserved								
2	KSO17_ALT	O			All PGS options	NA			
3	PWM8_ALT	O			All PGS options	NA			
4	Reserved								
5	Reserved								
Default:0	GPIO127	PIO		VTR1	All PGS options	No Gate	No	Yes	
1	A20M	O			All PGS options	NA			
2	UART1_RTS#	O			All PGS options	NA			
3	UART0_CTS#_ALT	I			All PGS options	High			
4	Reserved								
5	Reserved								
Default:0	GPIO156	PIO		VTR1	All PGS options	No Gate	Yes	Yes	The Over voltage protected GPIO pins will not support the Repeater mode mentioned in the GPIO pin configuration
1	LED0	O			All PGS options	NA			
2	Reserved								
3	Reserved								
4	Reserved								
5	Reserved								
Default:0	GPIO157	PIO		VTR1	All PGS options	No Gate	Yes	Yes	The Over voltage protected GPIO pins will not support the Repeater mode mentioned in the GPIO pin configuration
1	LED1	O			All PGS options	NA			
2	Reserved								
3	Reserved								
4	Reserved								
5	Reserved								

MEC1725

TABLE 2-2: MEC1725 176 WFBGA PIN MUX TABLE

Mux value	Signal Name	Buffer type	Drive Strength	PAD Power Well	Emulated Power Well	Gated State	OVP	BDP	Notes
Default:0	GPIO153	PIO		VTR1	All PGS options	No Gate	Yes	Yes	The Over voltage protected GPIO pins will not support the Repeater mode mentioned in the GPIO pin configuration
1	LED2	O			All PGS options	NA			
2	Reserved								
3	Reserved								
4	Reserved								
5	Reserved								
Default:0	GPIO007	PIO		VTR1	All PGS options	No Gate	Yes	Yes	The Over voltage protected GPIO pins will not support the Repeater mode mentioned in the GPIO pin configuration
1	I2C03_SDA	PIO			All PGS options	High			
2	PS2_CLK0B	PIO			All PGS options	Low			
3	Reserved								
4	Reserved								
5	Reserved								
Default:0	GPIO010	PIO		VTR1	All PGS options	No Gate	Yes	Yes	The Over voltage protected GPIO pins will not support the Repeater mode mentioned in the GPIO pin configuration
1	I2C03_SCL	PIO			All PGS options	High			
2	PS2_DAT0B	PIO			All PGS options	Low			
3	Reserved								
4	Reserved								
5	Reserved								
Default:0	GPIO154	PIO		VTR1	All PGS options	No Gate	No	Yes	
1	I2C02_SDA	PIO			All PGS options	High			
2	CPU_C10	I			All PGS options	Low			
3	Reserved								
4	Reserved								
5	Reserved								

TABLE 2-2: MEC1725 176 WFBGA PIN MUX TABLE

Mux value	Signal Name	Buffer type	Drive Strength	PAD Power Well	Emulated Power Well	Gated State	OVP	BDP	Notes
Default:0	GPIO155	PIO		VTR1	All PGS options	No Gate	No	Yes	
1	I2C02_SCL	PIO			All PGS options	High			
2	Reserved								
3	Reserved								
4	Reserved								
5	Reserved								
Default:0	GPIO045	PIO		VTR1	All PGS options	No Gate	No	Yes	
1	KSO01	O			All PGS options	NA			
2	PWM2_ALT	O			All PGS options	NA			
3	ICT14	I			All PGS options	Low			
4	Reserved								
5	Reserved								
Default:0	GPIO165	PIO		VTR1	All PGS options	No Gate	No	Yes	
1	32KHZ_IN	I			PGS=00 (only)	Low			
2	Reserved								
3	CTOUT0	O			All PGS options	NA			
4	Reserved								
5	Reserved								
Default:0	GPIO145	PIO		VTR1	All PGS options	No Gate	No	Yes	
1	I2C09_SDA	PIO			All PGS options	High			
2	Reserved								
3	Reserved								
4	JM_TDI	O			All PGS options	NA			
5	Reserved								
Default:0	GPIO146	PIO		VTR1	All PGS options	No Gate	No	Yes	
1	I2C09_SCL	PIO			All PGS options	High			
2	ITM	O			All PGS options	Low			
3	Reserved								
4	JM_TDO	I			All PGS options	Low			
5	Reserved								

MEC1725

TABLE 2-2: MEC1725 176 WFBGA PIN MUX TABLE

Mux value	Signal Name	Buffer type	Drive Strength	PAD Power Well	Emulated Power Well	Gated State	OVP	BDP	Notes
Default:0	GPIO147	PIO		VTR1	All PGS options	No Gate	No	Yes	
1	I2C15_SDA	PIO			All PGS options	High			
2	Reserved								
3	Reserved								
4	JM_TCLK	O			All PGS options	NA			
5	Reserved								
Default:0	GPIO150	PIO		VTR1	All PGS options	No Gate	No	Yes	
1	I2C15_SCL	PIO			All PGS options	High			
2	Reserved								
3	Reserved								
4	JM_TMS	O			All PGS options	NA			
5	Reserved								
Default:0	GPIO141	PIO		VTR1	All PGS options	No Gate	No	Yes	
1	I2C05_SDA	PIO			All PGS options	High			
2	Reserved								
3	SPI1_CLK	O			All PGS options	NA			
4	UART0_DCD#_ALT	I			All PGS options	NA			
5	Reserved								
Default:0	GPIO142	PIO		VTR1	All PGS options	No Gate	No	Yes	
1	I2C05_SCL	PIO			All PGS options	High			
2	Reserved								
3	SPI1_MOSI	PIO			All PGS options	NA			
4	UART0_DSR#_ALT	I			All PGS options	High			
5	Reserved								
Default:0	GPIO143	PIO		VTR1	All PGS options	No Gate	No	Yes	
1	I2C04_SDA	PIO			All PGS options	High			
2	Reserved								
3	SPI1_MISO	I			All PGS options	Low			
4	UART0_DTR#_ALT	O			All PGS options	NA			

TABLE 2-2: MEC1725 176 WFBGA PIN MUX TABLE

Mux value	Signal Name	Buffer type	Drive Strength	PAD Power Well	Emulated Power Well	Gated State	OVP	BDP	Notes
5	Reserved								
Default:0	GPIO144	PIO		VTR1	All PGS options	No Gate	No	Yes	
1	I2C04_SCL	PIO			All PGS options	High			
2	Reserved								
3	SPI1_CS#	O			All PGS options	NA			
4	UART0_RI#_ALT	I			All PGS options	High			
5	Reserved								
Default:0	GPIO004	PIO		VTR1	All PGS options	No Gate	No	Yes	
1	I2C00_SCL	PIO			All PGS options	High			
2	Reserved								
3	Reserved								
4	SPI0_MOSI	PIO			All PGS options	NA			
5	Reserved								
Default:0	GPIO003	PIO		VTR1	All PGS options	No Gate	No	Yes	
1	I2C00_SDA	PIO			All PGS options	High			
2	Reserved								
3	Reserved								
4	SPI0_CS0#	O			All PGS options	NA			
5	Reserved								
Default:0	GPIO162	PIO		VBAT	All PGS options	No Gate	No	Yes	
1	VCI_IN1#	I			PGS=00 (only)	No Gate			
2	Reserved								
3	Reserved								
4	Reserved								
5	Reserved								
NA	VCI_IN0#	I		VBAT	NA	No Gate	No	No	
NA	BGPO0	O	O2ma-Low	VBAT	NA	NA	No	Yes	
Default:1	BGPO1	O	O2ma-Low	VBAT	PGS=00 (only)	NA	No	Yes	
0	GPIO101	PIO			All PGS options	No Gate			
2	Reserved								

MEC1725

TABLE 2-2: MEC1725 176 WFBGA PIN MUX TABLE

Mux value	Signal Name	Buffer type	Drive Strength	PAD Power Well	Emulated Power Well	Gated State	OVP	BDP	Notes
3	Reserved								
4	Reserved								
5	Reserved								
Default:1	BGPO2	O	O2ma-Low	VBAT	PGS=00 (only)	NA	No	Yes	
0	GPIO102	PIO			All PGS options	No Gate			
2	Reserved								
3	Reserved								
4	Reserved								
5	Reserved								
Default:1	BGPO3	O	O2ma-Low	VBAT	PGS=00 (only)	NA	No	Yes	
0	GPIO172	PIO			All PGS options	No Gate			
2	Reserved								
3	Reserved								
4	Reserved								
5	Reserved								
NA	XTAL1	ICLK		VBAT	NA	NA	No	No	
1	Reserved								
2	Reserved								
3	Reserved								
4	Reserved								
5	Reserved								
NA	XTAL2	OCLK		VBAT	NA	NA	No	No	
1	Reserved								
2	Reserved								
3	Reserved								
4	Reserved								
5	Reserved								
Default:0	GPIO161	PIO		VBAT	All PGS options	No Gate	No	Yes	
1	VCI_IN2#	I			PGS=00 (only)	No Gate			
2	Reserved								
3	Reserved								
4	Reserved								
5	Reserved								
Default:0	GPIO117	PIO		VTR1	All PGS options	No Gate	No	Yes	
1	Reserved								
2	Reserved								
3	Reserved								

TABLE 2-2: MEC1725 176 WFBGA PIN MUX TABLE

Mux value	Signal Name	Buffer type	Drive Strength	PAD Power Well	Emulated Power Well	Gated State	OVP	BDP	Notes
4	Reserved								
5	Reserved								
Default:0	GPIO210	PIO		VTR1	All PGS options	No Gate	No	No	
1	ADC08	I_AN			PGS=00 (only)	Low			
2	Reserved								
3	Reserved								
4	Reserved								
5	Reserved								
Default:0	GPIO211	PIO		VTR1	All PGS options	No Gate	No	No	
1	ADC09	I_AN			PGS=00 (only)	Low			
2	Reserved								
3	Reserved								
4	Reserved								
5	Reserved								
Default:0	GPIO212	PIO		VTR1	All PGS options	No Gate	No	No	
1	ADC10	I_AN			PGS=00 (only)	Low			
2	Reserved								
3	Reserved								
4	Reserved								
5	Reserved								
Default:0	GPIO213	PIO		VTR1	PGS=00 (only)	No Gate	No	No	
1	ADC11	I_AN			PGS=00 (only)	Low			
2	Reserved								
3	Reserved								
4	Reserved								
5	Reserved								
Default:0	GPIO214	PIO		VTR1	PGS=00 (only)	No Gate	No	No	
1	ADC12	I_AN			PGS=00 (only)	Low			
2	Reserved								
3	Reserved								
4	Reserved								
5	Reserved								
Default:0	GPIO215	PIO		VTR1	All PGS options	No Gate	No	No	

MEC1725

TABLE 2-2: MEC1725 176 WFBGA PIN MUX TABLE

Mux value	Signal Name	Buffer type	Drive Strength	PAD Power Well	Emulated Power Well	Gated State	OVP	BDP	Notes
1	ADC13	I_AN			PGS=00 (only)	Low			
2	Reserved								
3	Reserved								
4	Reserved								
5	Reserved								
Default:0	GPIO216	PIO		VTR1	All PGS options	No Gate	No	No	
1	ADC14	I_AN			PGS=00 (only)	Low			
2	Reserved								
3	Reserved								
4	Reserved								
5	Reserved								
Default:0	GPIO217	PIO		VTR1	All PGS options	No Gate	No	No	
1	ADC15	I_AN			PGS=00 (only)	Low			
2	Reserved								
3	Reserved								
4	Reserved								
5	Reserved								
Default:0	GPIO133	PIO		VTR1	All PGS options	No Gate	No	Yes	
1	PWM9	O			All PGS options	NA			
2	Reserved								
3	Reserved								
4	Reserved								
5	Reserved								
Default:0	GPIO134	PIO		VTR1	All PGS options	No Gate	No	Yes	
1	PWM10	O			All PGS options	NA			
2	UART1_RTS#_ALT	O			All PGS options	NA			
3	Reserved								
4	Reserved								
5	Reserved								
Default:0	GPIO001	PIO		VTR2	All PGS options	No Gate	No	Yes	
1	PWM4_ALT	O			All PGS options	NA			
2	Reserved								
3	Reserved								

TABLE 2-2: MEC1725 176 WFBGA PIN MUX TABLE

Mux value	Signal Name	Buffer type	Drive Strength	PAD Power Well	Emulated Power Well	Gated State	OVP	BDP	Notes
4	Reserved								
5	Reserved								
Default:1	SYSPWR_PRES	I		VBAT	PGS=00 (only)	No Gate	No	Yes	
0	Reserved								
2	Reserved								
3	Reserved								
4	Reserved								
5	Reserved								
Default:0	GPIO006	PIO		VTR1	All PGS options	No Gate	No	Yes	
1	I2C11_SCL_ALT	PIO	#VALUE!		All PGS options	High			
2	GPTP_OUT7	O			All PGS options	NA			
3	Reserved								
4	Reserved								
5	Reserved								
Default:0	GPIO166	PIO		VTR1	All PGS options	No Gate	No	Yes	
1	Reserved								
2	PWRGD_S0iX-ALT	I			PGS=00 (only)	High			
3	Reserved								
4	Reserved								
5	Reserved								
Default:1	VCI_OVRD_IN	I		VBAT	NA	No Gate	No	No	
0	Reserved								
2	Reserved								
3	Reserved								
4	Reserved								
5	Reserved								
Default:0	GPIO005	PIO		VTR1	All PGS options	No Gate	No	Yes	
1	I2C11_SDA_ALT	PIO			All PGS options	High			
2	GPTP_OUT4	O			All PGS options	NA			
3	Reserved								
4	Reserved								
5	Reserved								
Default:0	GPIO041	PIO		VTR1	All PGS options	No Gate	No	Yes	
1	Reserved								

MEC1725

TABLE 2-2: MEC1725 176 WFBGA PIN MUX TABLE

Mux value	Signal Name	Buffer type	Drive Strength	PAD Power Well	Emulated Power Well	Gated State	OVP	BDP	Notes
2	EMC_SYS-SHDN#	O			PGS=00 (only)	NA			
3	Reserved								
4	Reserved								
5	Reserved								
Default:0	GPIO225	PIO		VTR1	All PGS options	No Gate	No	Yes	
1	UART0_RTS#_ALT	O			All PGS options	NA			
2	Reserved								
3	Reserved								
4	Reserved								
5	Reserved								
Default:0	GPIO135	PIO		VTR1	All PGS options	No Gate	No	Yes	
1	UART1_CTS#_ALT	I			All PGS options	High			
2	Reserved								
3	Reserved								
4	Reserved								
5	Reserved								
Default:0	GPIO103 (Thermtrip2#)	PIO		VTR1	All PGS options	No Gate	No	Yes	The THERMTRIP2# and GPIO103 share the same pin. While THERMTRIP2# is not enabled in EMC block, the pin can be used as GPIO103. When THERMTRIP2# is enabled in EMC block, the pin acts as THERMTRIP2# pin and the EC Firmware can read THERMTRIP2# value using GPIO103 at any instance without problem
1	Reserved								
2	Reserved								
3	Reserved								
4	Reserved								
5	Reserved								
Default:0	GPIO160	PIO		VTR1	All PGS options	No Gate	No	Yes	
1	PWM11	O			All PGS options	NA			

TABLE 2-2: MEC1725 176 WFBGA PIN MUX TABLE

Mux value	Signal Name	Buffer type	Drive Strength	PAD Power Well	Emulated Power Well	Gated State	OVP	BDP	Notes
2	PROCHOT_IN#	I			All PGS options	High			
3	PROCHOT_IO#	IO			All PGS options	High			
4	Reserved								
5	Reserved								
Default:0	GPIO233	PIO		VTR2	All PGS options	No Gate	No	Yes	
1	Reserved								
2	Reserved								
3	Reserved								
4	Reserved								
5	Reserved								
Default:0	GPIO111	PIO		VTR2	All PGS options	No Gate	No	Yes	
1	Reserved								
2	Reserved								
3	Reserved								
4	Reserved								
5	Reserved								
Default:0	GPIO231	PIO		VTR2	All PGS options	No Gate	No	Yes	
1	I2C08_SDA	PIO			All PGS options	High			
2	Reserved								
3	Reserved								
4	Reserved								
5	Reserved								
Default:0	GPIO110	PIO		VTR2	All PGS options	No Gate	No	Yes	
1	Reserved								
2	Reserved								
3	Reserved								
4	Reserved								
5	Reserved								
Default:0	GPIO230	PIO		VTR2	All PGS options	No Gate	No	Yes	
1	I2C08_SCL	PIO			All PGS options	High			
2	Reserved								
3	Reserved								
4	Reserved								
5	Reserved								
NA	VCI_OUT1	O	O2ma-High	VBAT	NA	No Gate	No	Yes	

MEC1725

TABLE 2-2: MEC1725 176 WFBGA PIN MUX TABLE

Mux value	Signal Name	Buffer type	Drive Strength	PAD Power Well	Emulated Power Well	Gated State	OVP	BDP	Notes
Default:0	GPIO074	PIO		VTR1	All PGS options	No Gate	No	Yes	
1	Reserved								
2	Reserved								
3	Reserved								
4	Reserved								
5	Reserved								
Default:0	GPIO075	PIO		VTR1	All PGS options	No Gate	No	Yes	
1	Reserved								
2	Reserved								
3	Reserved								
4	Reserved								
5	Reserved								
Default:0	GPIO076	PIO		VTR1	All PGS options	No Gate	No	Yes	
1	Reserved								
2	Reserved								
3	Reserved								
4	Reserved								
5	Reserved								

TABLE 2-3: MEC1725 DEDICATED PIN INFORMATION TABLE

Signal Name	Buffer Type	Drive Strength	PAD Power Well	Notes
THERMTRIP1#	In		VTR_A	
DP1_DN1A	I_AN		VTR_A	
DN1_DP1A	I_AN		VTR_A	
DP2_DN2A	I_AN		VTR_A	
DN2_DP2A	I_AN		VTR_A	
DP3_DN3A	I_AN		VTR_A	
DN3_DP3A	I_AN		VTR_A	
DP4_DN4A	I_AN		VTR_A	
DN4_DP4A	I_AN		VTR_A	
VCP	I_AN		VTR_A	
VSET	I_AN		VTR_A	
VIN	I_AN		VTR_A	

2.4.11 CONFIGURABLE SIGNAL ROUTING

Host interface signals, nEC_SCI and nSMI are routed on 2 pins, one that's powered by VTR1 and other VTR3. This is to accommodate 3.3/1.8V signaling on these based on the Host. The signal routing is determined by the alternate function multiplexer programmed in the pin's GPIO [Pin Control Register](#). Software should not enable signals on more than one pin.

To accommodate the signal routing across packages, some Signals are routed to more than one GPIO. At any given time, only the <Signal> or <Signal>_ALT can be selected. Both cannot be selected at the same time.

TABLE 2-4: GPIO ALTERNATE FUNCTIONS

Function	GPIO <Signal>	Alternate GPIO <Signal>_ALT	Second Alternate GPIO <Signal>_ALT2
32kHz_OUT	GPIO221	GPIO022	
I2C07_SCL	GPIO013	GPIO024	
I2C07_SDA	GPIO012	GPIO152	
I2C01_SCL	GPIO131	GPIO073	
I2C01_SDA	GPIO130	GPIO072	
I2C11_SCL	GPIO062	GPIO006	
I2C11_SDA	GPIO000	GPIO005	
ICT5	GPIO140	GPIO065	
CTOUT1	GPIO035	GPIO246	
PWM6	GPIO014	GPIO063	
PWM11	GPIO160	GPIO222	
PWM8	GPIO035	GPIO175	
PWM3	GPIO056	GPIO047	
PWM0	GPIO053	GPIO241	
PWM2	GPIO055	GPIO045	
PWM4	GPIO011	GPIO001	
PROCHOT#	GPIO160	GPIO222	
TFDP_DATA	GPIO171	GPIO105	
TFDP_CLK	GPIO170	GPIO104	
KSO17	GPIO140	GPIO175	
UART0_RTS#	GPIO144	GPIO255	
UART0_CTS#	GPIO143	GPIO127	
UART0_DCD#	GPIO017	GPIO141	
UART0_DSR#	GPIO027	GPIO142	
UART0_DTR#	GPIO026	GPIO143	
UART0_RI#	GPIO032	GPIO144	
UART0_TX	GPIO104	GPIO166	
UART0_RX	GPIO105	GPIO041	
UART1_RX	GPIO171	GPIO255	
UART1_RTS#	GPIO127	GPIO134	
UART1_CTS#	GPIO040	GPIO135	
UART1_DSR#	GPIO255	GPIO232	
VCC_PWRGD	GPIO057	GPIO242	
PWRGD_S0iX	GPIO226	GPIO166	GPIO246
PWROK	GPIO106	GPIO244	
nSMI	GPIO107	GPIO011	
nEC_SCI	GPIO114	GPIO100	
POK_PCH	GPIO012	GPIO022	
VCCPOK	GPIO130	GPIO024	

MEC1725

TABLE 2-4: GPIO ALTERNATE FUNCTIONS (CONTINUED)

Function	GPIO <Signal>	Alternate GPIO <Signal>_ALT	Second Alternate GPIO <Signal>_ALT2
IMVP_VR_ON	GPIO013	GPIO023	
POKS0	GPIO131	GPIO221	

2.4.12 SIGNAL DESCRIPTION BY INTERFACE

TABLE 2-5: PIN DESCRIPTION TABLE

SIG_NAME	Description	Notes
ADC		
ADCxx	ADC channel x	Note 1
VREF_ADC	ADC Reference Voltage	
VREF2_ADC	Alternate Vref for ADC	
ESPI		
ESPI_ALERT#	eSPI Alert	Note 9
ESPI_CLK	eSPI Clock	
ESPI_CS#	eSPI Chip Select	Note 9
ESPI_IOx	eSPI Data Pin x	
ESPI_RESET#	eSPI Reset	Note 9
HOST interface		
nEC_SCI	Power management event	Note 8
nEMI_INT	EC to host Interrupt output	
MailBox		
nSMI	SMI output	
KYBD Controller		
A20M	KBD GATEA20 Output	
KBRST	CPU_RESET	
PWM LED		
LEDx	LED (Blinking/Breathing PWM) PWM Output x	Note 1
Debug		
TFDP_CLK	Trace FIFO debug port - clock	
TFDP_DATA	Trace FIFO debug port - data	
JTAG_RST#	JTAG test active low reset	Note 9
JTAG_TDI	JTAG test data in	Note 11, Note 12, Note 15
JTAG_TDO	JTAG test data out	Note 11, Note 12, Note 15
JTAG_CLK	JTAG test clk; SWDCLK	Note 11, Note 12, Note 15
JTAG_TMS	JTAG test mode select; SWDIO	Note 11, Note 12, Note 15
JM_TDI	Muxed on JTAG_TDI pin JTAG Master TDI	Note 15
JM_TDO	Muxed on JTAG_TDO pin JTAG Master TDO	Note 15
JM_CLK	Muxed on JTAG_TCK pin JTAG Master TCK	Note 15

TABLE 2-5: PIN DESCRIPTION TABLE

SIG_NAME	Description	Notes
JM_TMS	Muxed on JTAG_TMS pin JTAG Master TMS	Note 15
TRACECLK	ARM Embedded Trace Macro Clock	
TRACEDATAx	ARM Embedded Trace Macro Data x	Note 1
Slave SPI		
SLV_SPI_CS#	Slave SPI Chip Select	Note 9
SLV_SPI_SCLK	Slave SPI Clock	Note 17
SLV_SPI_IOx	Slave SPI Data x	Note 1
SLV_SPI_MSTR_INT	Slave SPI interrupt to Master	
KeyScan		
KSix	Keyboard Scan Matrix Input x	Note 1, Note 7
KSOxx	Keyboard Scan Matrix Output xx	Note 1, Note 7
SMBus/I2C Controller		
I2Cxx_SDA	I2C/SMBus Controller Port x Data	Note 1, Note 3
I2Cxx_SCL	I2C/SMBus Controller Port x Clock	
SB-TSI_DAT	I2C Controller AMD-TSI port data	
SB-TSI_CLK	I2C Controller AMD-TSI port clock	
GPIO		
GPIOx	General Purpose Input Output Pins	Note 1, Note 16
GPTP_INx	General purpose pass through port inputx	Note 1, Note 13
GPTP_OUTx	General purpose pass through port outputx	Note 1, Note 13
PCR		
XTAL1	32.768 KHz Crystal Input	Note 5
XTAL2	32.768 KHz Crystal Output (single-ended 32.768 KHz clock input)	
32KHZ_OUT	32.768 KHz Digital Output	
32KHZ_IN	32.768 KHz Digital Input	
TST_CLK_OUT	48MHz System clock output	Note 6
nRESET_IN	External System Reset Input	
VCC_PWRGD	System Main Power Indication Input	
PWROK	System Main Power Indication Output	
PWRGD_S0IX	Power good input from alternate power supply in S0ix mode	
SLP_S0#	SLP_S0# input to detect connected standby	Note 9
CPU_C10	CPU_C10 input to detect connected standby	
RC-ID		
RC_IDx	RC identification detection x	Note 1
PECI		
PECI_DAT	PECI Bus	
VREF_VTT	Processor Interface Voltage Reference	Note 4
QMSPI		
PVT_CS#	Private SPI Chip Select; SPI_CS# of QMSPI Controller	Note 9
PVT_IOx	Private SPI Data x; SPI_IOx of QMSPI Controller	Note 1
PVT_CLK	Private SPI Clock; SPI_CLK of QMSPI Controller	Note 17
SHD_CS1#	Shared SPI Chip Select1	Note 9

MEC1725

TABLE 2-5: PIN DESCRIPTION TABLE

SIG_NAME	Description	Notes
SHD_CS0#	Shared SPI Chip Select; SPI_CS# of QMSPI Controller	Note 9
SHD_IOx	Shared SPI Data x; SPI_IOx of QMSPI Controller	Note 1
SHD_CLK	Shared SPI Clock ; SPI_CLK of QMSPI Controller	Note 18
FAN TACH		
ICT0_TACH0	Fan Tachometer Input 0	
ICT1_TACH1	Fan Tachometer Input 1	
ICT2_TACH2	Fan Tachometer Input 2	
TACH3	Fan Tachometer Input 3	
GPWMx	PWM Output from RPM-based Fan Speed Control Algorithm	Note 1
PWM		
PWMx	Pulse Width Modulator Output x	Note 1
ICT		
ICTx	Input capture timer input x	Note 1
CTOUTx	Compare timer x toggle output	Note 1
16-Bit Counter/Timer Interface		
TINx	16-Bit Counter/Timer Inputx	Note 1
TOUTx	16-Bit Counter/Timer Outputx	Note 1
PS2		
PS2_CLK0A	PS/2 clock 0 - Port A	Note 10
PS2_DAT0A	PS/2 data 0 - Port A	
PS2_CLK0B	PS/2 clock 0 - Port B	Note 10
PS2_DAT0B	PS/2 data 0 - Port B	
UART		
UART_CLK	UART Baud Clock Input	
UARTx_CTS#	Clear to Send Input	Note 1,Note 9
UARTx_DCD#	Data Carrier Detect Input	Note 1,Note 9
UARTx_DSR#	Data Set Ready Input	Note 1,Note 9
UARTx_DTR#	Data Terminal Ready Output	Note 1,Note 9
UARTx_RI#	Ring Indicator Input	Note 1,Note 9
UARTx_RTS#	Request to Send Output	Note 1,Note 9
UARTx_RX	UART Receive Data (RXD)	Note 1
UARTx_TX	UART Transmit Data (TXD)	Note 1
BGPO		
BGPO0	Battery Powered General Purpose Output	
BGPOx	Battery Powered General Purpose Output	Note 1
VCI		
VCI_IN0#	Input can cause wakeup or interrupt event	Note 9
VCI_INx#	Input can cause wakeup or interrupt event	Note 1,Note 9,Note 14
VCI_OUT	Output from combinatorial logic and/or EC	
VCI_OVRD_IN	Input can cause wakeup or interrupt event	
SYSPWR_PRES	VBAT Input, System Power Present	
SYS_SHDN#	System Main Power Shut down	Note 9

TABLE 2-5: PIN DESCRIPTION TABLE

SIG_NAME	Description	Notes
PROCHOT Monitor		
PROCHOT_IN#	Prochot input	Note 9
PROCHOT_IO#	Prochot IO signal	Note 9
Power		
VTR_ANALOG	Analog supply	
VSS_ANALOG	Analog Supply associated ground	
VSS_ADC	Analog ADC supply associated ground	
VBAT	VBAT supply	
VR_CAP	Internal Voltage Regulator Capacitor	Note 2
VSSx	VTRx associated ground	Note 1
VSS_VBAT	VBAT associated ground	
VTR1	VTR Suspend Power Supply	
VTR3	Host Interface Power Supply	
VTR2	Peripheral Power Supply	
VTR_PLL	PLL power supply	
VTR_REG	Regulator power supply	
Thermal Monitor Interface		
DN1_DP1A	Positive input for a thermal diode1, Negative input for anti-parallel thermal diode 1a	
DN2_DP2A	Positive input for thermal diode 2, Negative input for anti-parallel thermal diode 2a	
DN3_DP3A	Positive input for thermal diode 3, Negative input for anti-parallel thermal diode 3a	
DN4_DP4A	Positive input for thermal diode 4, Negative input for anti-parallel thermal diode 4a	
DP1_DN1A	Negative input for thermal diode 1, Positive input for anti-parallel thermal diode 1a	
DP2_DN2A	Negative input for thermal diode 2, Positive input for anti-parallel thermal diode 2a	
DP3_DP3A	Negative input for thermal diode 3, Positive input for anti-parallel thermal diode 3a	
DP4_DP4A	Negative input for thermal diode 4, Positive input for anti-parallel thermal diode 4a	
THERMTRIP1#	ThermTrip Input from CPU	Note 9
THERMTRIP2#	ThermTrip Input from CPU	Note 9
VCP	5V Voltage Input	
VIN	Calibration Voltage Input	
VSET	Temp. Threshold Voltage Input	
Notes for the Pin description table		

TABLE 2-5: PIN DESCRIPTION TABLE

SIG_NAME	Description	Notes
	<p>Note 1: x' is the number of the signals in the chip. Please refer Pin List in the Pin configuration chapter to know the number of signals in each interface available</p> <p>2: An external cap must be connected as close to the CAP pin/ball as possible with a routing resistance and CAP ESR of less than 100mohms. The capacitor value is 1uF and must be ceramic with X5R or X7R dielectric. The cap pin/ball should remain on the top layer of the PCB and traced to the CAP. Avoid adding vias to other layers to minimize inductance.</p> <p>3: This SMBus ports supports 1 Mbps operation as defined by I2C. For 1 Mbps I2C recommended capacitance/pull-up relationships from Intel, refer to the Shark Bay platform guide, Intel ref number 486714. Refer to the PCH - SMBus 2.0/SMLink Interface Design Guidelines, Table 20-5 Bus Capacitance/Pull-Up Resistor Relationship.</p> <p>4: In order to achieve the lowest leakage current when both PECl and SB TSl are not used, set the VREF_VTT Disable bit to 1</p> <p>5: The XTAL1 pin should be left floating when using the XTAL2 pin for the single ended clock input.</p> <p>6: This signal is a test signal used to detect when the internal 48MHz clock is toggling or stopped in heavy and deepest sleep modes.</p> <p>7: The KSl and KSO Key Scan pins require pull-up resistors. The system designer may opt to use either use the internal pull-up resistors or populate external pull-up resistors.</p> <p>8: The nEC_SCl pin can be controlled by hardware and EC firmware. The nEC_SCl pin can drive either the ACPI Run-time GPE Chipset input or the Wake GPE Chipset input. Depending how the nEC_SCl pin is used, other ACPI-related SCl functions may be best supplied by other general purpose outputs that can be configured as open-drain drivers.</p> <p>9: <Signal> with '#' as suffix will be shown as <Signal>_n in MPLab Tools</p> <p>10: PS/2 ports ending with signal functions ending with "A" or "B" are muxed to a single controller. Only one set of clock and data are intended to used at a time (either "A" or "B" not both. The unused port segment should have its associated pin control register's, Mux Control Field programmed away from the PS2 controller.</p> <p>11: The JTAG signals TDI,TDO,TMS,TCK are muxed with GPIO pins. Routing of JTAG signals to these pins are dependent on DEBUG ENABLE REGISTER bits [2:0] and JTAG_RST# pin. To configure these GPIO pins for non JTAG functions, pull JTAG_RST# low externally and select the appropriate alternate function in the Pin Control Register</p> <p>12: When the JTAG_RST# pin is not asserted (logic'1'), the JTAG or ARM SWJ signal functions in the JTAG interface are unconditionally routed to the GPIO interface; the Pin Control register for these GPIO pins has no effect. When the JTAG_RST# pin is asserted (logic'0'), the signal functions in the JTAG interface are not routed to the interface and the Pin Control Register for these GPIO pins controls the muxing. The pin control registers can not route the JTAG interface to the pins. System Board Designer should terminate this pin in all functional state using jumpers and pull-up or pull down resistors, etc.</p> <p>13: The GPTP_OUT always drives at the level of the output buffer regardless of the voltage at the GPTP_IN pin. If the GPTP_IN pin is 1.8V the output essentially level-shifts the voltage up to 3.3V, as GPTP_OUT pins are powered by VTR1 (3.3V)</p> <p>14: These VCI pins may be used as GPIOs as well. The VCI input signals are not gated by selecting the GPIO alternate function. Firmware must disable (i.e., gate) these inputs by writing the bits in the VCI Input Enable Register when the GPIO function is enabled</p> <p>15: External Pullup is required on the JTAG pins when used for debug operation</p> <p>16: The THERMTRIP2# and GPIO103 share the same pin. While THERMTRIP2# is not enabled in EMC block, the pin can be used as GPIO103. When THERMTRIP2# is enabled in EMC block, the pin acts as THERMTRIP2# pin and the EC Firmware can read THERMTRIP2# value using GPIO103 at any instance without problem.</p> <p>17: The maximum clock frequency of this interface is 48MHz</p> <p>18: The maximum clock frequency of this interface is 96MHz for single SPI. If the SPI flash is shared by more than one master, the maximum clock frequency of this interface is 48MHz.</p>	

2.4.13 STRAPPING OPTIONS

GPIO170 is used for the TAP Controller select strap. If any of the JTAG TAP controllers are used, GPIO170 must only be configured as an output to a VTRx powered external function. GPIO170 may only be configured as an input when the JTAG TAP controllers are not needed or when an external driver does not violate the Slave Select

TABLE 2-6: STRAP PINS

Pin Name	Strap Name	Strap Define and Value	I/O Power Rail
GPIO170	JTAG_STRAP	1=Use the JAG TAP Controller for Boundary Scan 0=The JTAG TAP Controller is used for debug (normal operation)	VTR1
GPIO045	CR_STRAP	Crisis Recovery Strap 1=Normal Boot Source 0=Use the Private SPI pins to boot from Crisis Recovery flash over Key scan connector Note: This pin requires an external pull-up for normal operation.	VTR1
GPIO055/SHD_CS0#	BSS_STRAP	Boot Source Select Strap 1=Use the Shared SPI pins for Boot Note 2 0=Use the eSPI Flash Channel for Boot Note 1	VTR2
GPIO126	UART_BSTRAP	Crisis Recovery over UART 1=Normal Operation 0=Use UART interface for Crisis recovery Note 2	VTR1
GPIO227	PWRGD_STRAP	Power Good	VTR1
<p>Note 1: If the eSPI Flash Channel is used for booting, i.e., eSPI Master Attached Flash Sharing (MAFS), the GPIO055/PWM2/SHD_CS0# pin must be used as RSMRST#. This pin will be driven high by the boot ROM code in order to activate the eSPI flash channel. In addition, the GPIO016/GPT-P_IN1/SHD_IO3/ICT3 pin must be used as DSW_PWROK. This pin will also be driven high by the boot ROM code to support Deep Sleep Well timing requirements</p> <p>2: If the Shared SPI port is used for booting, then any unused GPIO may be used for RSMRST#. OTP byte 115 bit [3] allows selection of UART0/UART1 for Crisis Recovery, if UART_BSTRAP is enabled and sampled as 0x0.</p>			

2.5 Pin Default State Through Power Transitions

The power state and power state transitions illustrated in the following tables are defined in [Section 4.0, "Power, Clocks, and Resets"](#). Pin behavior in this table assumes no specific programming to change the pin state. All GPIO default pins that have the same behavior are described in the table generically as GPIOXXX.

TABLE 2-7: PIN DEFAULT STATE THROUGH POWER TRANSITIONS

Signal	VBAT Applied	VBAT Stable	VTR Applied	RESET_SYS De-asserted	VCC_PWRGD Asserted	VCC_PWRGD De-asserted	RESET_SYS Asserted	VTR Un-powered	VBAT Un-powered	Note
GPIO062	un-powered	un-powered	Low	Out=0	Out	Out	Z	glitch	un-powered	
GPIO170	un-powered	un-powered	High	In	In	In	Z	glitch	un-powered	
GPIOXXX	un-powered	un-powered	Z	Z	Z	Z	Z	glitch	un-powered	Note D
nRESET_IN	un-powered	un-powered	Low	In	In	In	Z	glitch	un-powered	

MEC1725

TABLE 2-7: PIN DEFAULT STATE THROUGH POWER TRANSITIONS

Signal	VBAT Applied	VBAT Stable	VTR Applied	RESET_SYS De-asserted	VCC_PWRGD Asserted	VCC_PWRGD De-asserted	RESET_SYS Asserted	VTR Un-powered	VBAT Un-powered	Note
VCI_INx#	In	In	In	In	In	In	In	In	un-powered	
VCI_OUT	Out logic	Out logic	Out logic	Out logic	Out logic	Out logic	Out logic	Out logic	un-powered	Note C

<p>Legend (P) = I/O state is driven by protocol while power is applied. Z = Tristate In = Input</p>	<p>Notes Note D: Does not include GPIO062 and GPIO170 Note B: Pin is programmable by the EC and retains its value through a VTR power cycle.</p>
--	---

TABLE 2-8: PIN DEFAULT STATE THROUGH POWER TRANSITIONS

Signal	VBAT Applied	VBAT Stable	VTR Applied	RESET_SYS De-asserted	VCC_PWRGD Asserted	VCC_PWRGD De-asserted	RESET_SYS Asserted	VTR Un-powered	VBAT Un-powered	Note
nSMI	N/A	N/A	N/A	N/A	1> OD(P)> 1	OD(1)	In	glitch	N/A	
KBRST	N/A	N/A	N/A	N/A	1> OD(P)> 1	Z	Z>In	glitch	N/A	Note F
A20M	N/A	N/A	N/A	N/A	1> OD(P)> 1	Z	Z	glitch	N/A	Note F

<p>Legend (P) = I/O state is driven by protocol while power is applied. Z = Tristate In = Input OD = Open Drain Output Undriven (1) or driven (0)</p>	<p>Notes Note F: Pin is programmable by the EC and retains its value through a VTR power cycle</p>
---	---

2.6 Package Information

2.6.1 176 PIN WFBGA/LJ PACKAGE

Note: For the most current package drawings, please see the Microchip Packaging Specification located at <http://www.microchip.com/packaging>

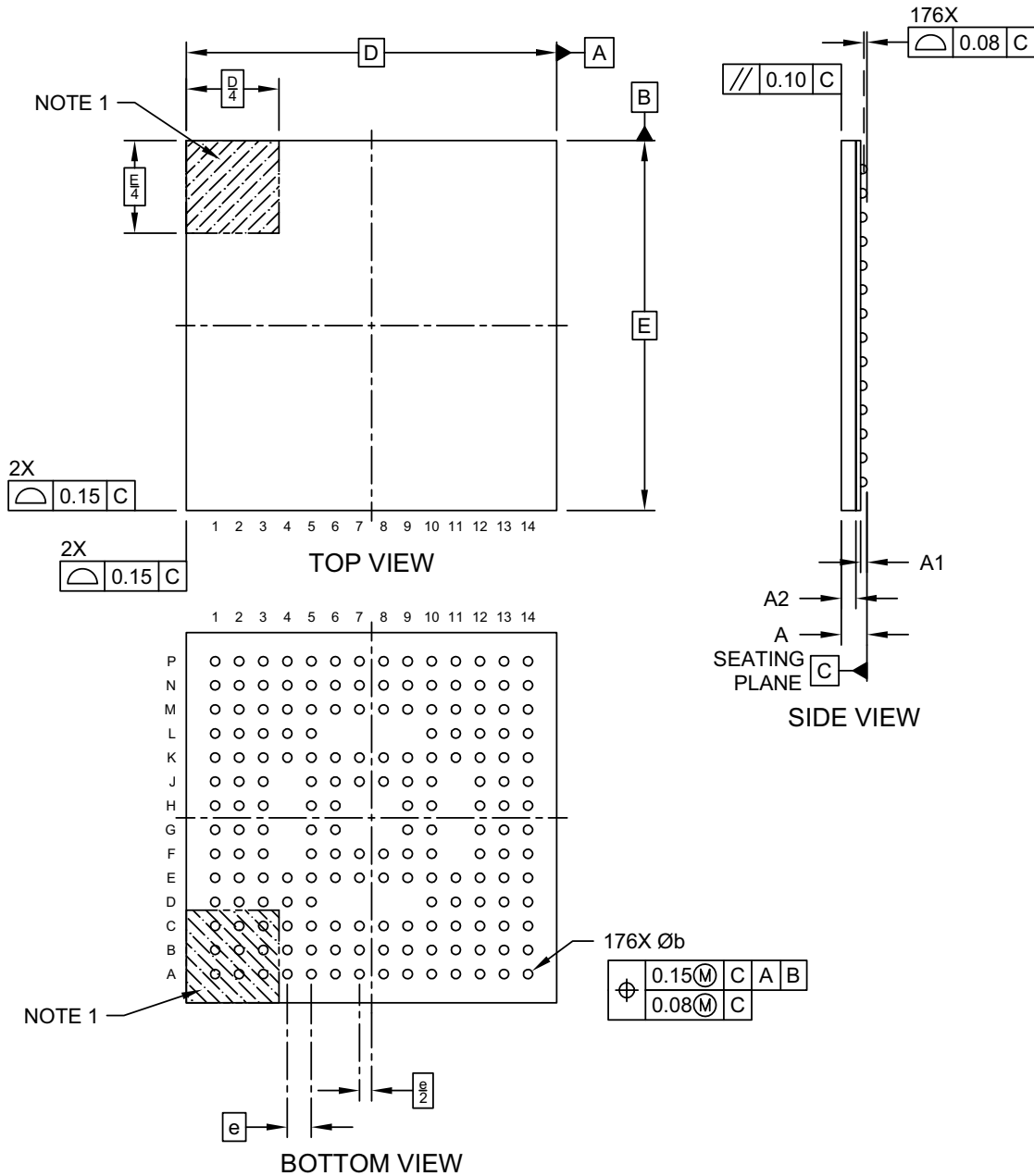

Microchip Technology Drawing C04-498 Rev A Sheet 1 of 2

© 2019 Microchip Technology Inc.

MEC1725

Note: For the most current package drawings, please see the Microchip Packaging Specification located at <http://www.microchip.com/packaging>

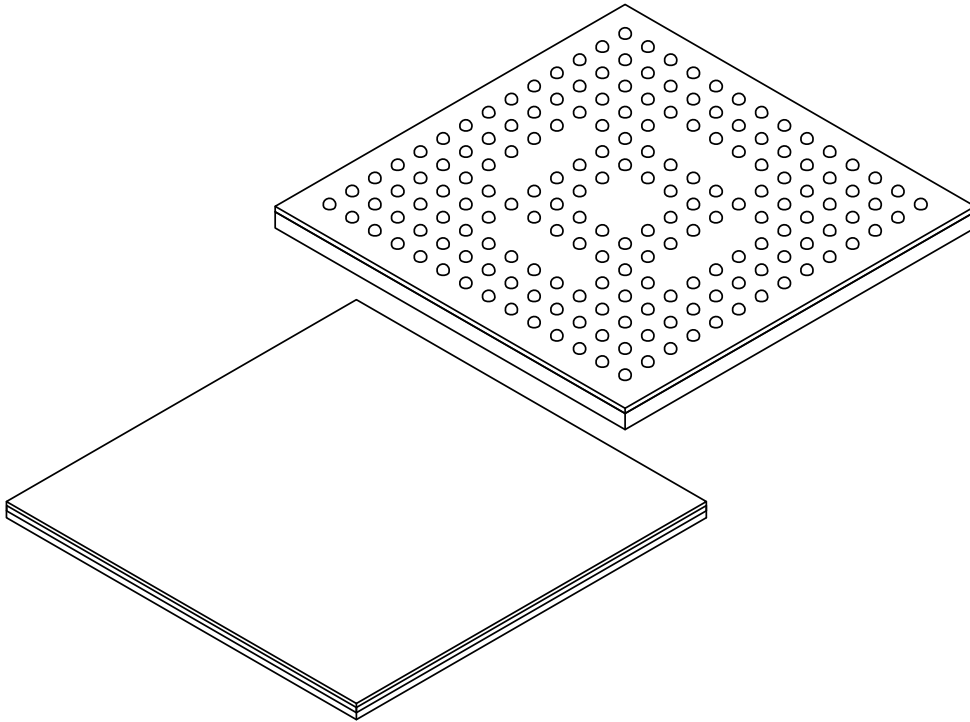

Dimension Limits	Units	MILLIMETERS		
		MIN	NOM	MAX
Number of Terminals	N	176		
Pitch	e	0.65 BSC		
Overall Height	A	-	-	0.80
Standoff	A1	0.12	0.17	-
Mold Cap Thickness	A2	0.35	0.40	0.45
Overall Length	D	10.00 BSC		
Overall Width	E	10.00 BSC		
Ball Diameter	b	0.20	0.25	0.30

Notes:

- Terminal A1 visual index feature may vary, but must be located within the hatched area.
- Dimensioning and tolerancing per ASME Y14.5M
 BSC: Basic Dimension. Theoretically exact value shown without tolerances.
 REF: Reference Dimension, usually without tolerance, for information purposes only.

Microchip Technology Drawing C04-498 Rev A Sheet 2 of 2

© 2019 Microchip Technology Inc.

3.0 DEVICE INVENTORY

3.1 Conventions

Term	Definition
Block	Used to identify or describe the logic or IP Blocks implemented in the device.
Reserved	Reserved registers and bits defined in the following table are read only values that return 0 when read. Writes to these reserved registers have no effect.
TEST	Microchip Reserved locations which should not be modified from their default value. Changing a TEST register or a TEST field within a register may cause unwanted results.
b	The letter 'b' following a number denotes a binary number.
h	The letter 'h' following a number denotes a hexadecimal number.

Register access notation is in the form "Read / Write". A Read term without a Write term means that the bit is read-only and writing has no effect. A Write term without a Read term means that the bit is write-only, and assumes that reading returns all zeros.

Register Field Type	Field Description
R	Read: A register or bit with this attribute can be read.
W	Write: A register or bit with this attribute can be written.
RS	Read to Set: This bit is set on read.
RC	Read to Clear: Content is cleared after the read. Writes have no effect.
WC or W1C	Write One to Clear: writing a one clears the value. Writing a zero has no effect.
WZC	Write Zero to Clear: writing a zero clears the value. Writing a one has no effect.
WS or W1S	Write One to Set: writing a one sets the value to 1. Writing a zero has no effect.
WZS	Write Zero to Set: writing a zero sets the value to 1. Writing a one has no effect.

MEC1725

3.2 Block Overview and Base Addresses

Table 3-1, "Base Address" lists all the IP components, referred to as Blocks, implemented in the design. The registers implemented in each block are accessible by the embedded controller (EC) at an offset from the Base Address shown in Table 3-1, "Base Address". The registers can also be accessed by various hosts in the system as below

1. eSPI: Via a bank of Configuration and Runtime Registers as explained in Chapter 10.0, "Enhanced Serial Peripheral Interface (eSPI)".
2. I2C : I2C host access is handled by firmware.
3. JTAG : JTAG port has access to all the registers defined in Table 3-1, "Base Address".

TABLE 3-1: BASE ADDRESS

Feature	Instance	Logical Device Number	Base Address
Watchdog Timer			4000_0400h
16-bit Basic Timer	0		4000_0C00h
16-bit Basic Timer	1		4000_0C20h
16-bit Basic Timer	2		4000_0C40h
16-bit Basic Timer	3		4000_0C60h
32-bit Basic Timer	0		4000_0C80h
32-bit Basic Timer	1		4000_0CA0h
16-bit Counter Timer	0		4000_0D00h
16-bit Counter Timer	1		4000_0D20h
16-bit Counter Timer	2		4000_0D40h
16-bit Counter Timer	3		4000_0D60h
Capture-Compare Timers			4000_1000h
RC-ID	0		4000_1400h
RC-ID	1		4000_1480h
RC-ID	2		4000_1500h
DMA Controller			4000_2400h
PowerGuard	0		4000_3000h
PowerGuard	1		4000_3080h
SMB-I2C Controller	0		4000_4000h
SMB-I2C Controller	1		4000_4400h
SMB-I2C Controller	2		4000_4800h
SMB-I2C Controller	3		4000_4C00h
SMB-I2C Controller	4		4000_5000h
Quad Master SPI			4007_0000h
16-bit PWM	0		4000_5800h
16-bit PWM	1		4000_5810h
16-bit PWM	2		4000_5820h
16-bit PWM	3		4000_5830h
16-bit PWM	4		4000_5840h
16-bit PWM	5		4000_5850h
16-bit PWM	6		4000_5860h
16-bit PWM	7		4000_5870h
16-bit PWM	8		4000_5880h
16-bit PWM	9		4000_5890h
16-bit PWM	10		4000_58A0h
16-bit PWM	11		4000_58B0h

TABLE 3-1: BASE ADDRESS

Feature	Instance	Logical Device Number	Base Address
16-bit Tach	0		4000_6000h
16-bit Tach	1		4000_6010h
16-bit Tach	2		4000_6020h
16-bit Tach	3		4000_6030h
PECI			4000_6400h
RTOS Timer			4000_7400h
ADC			4000_7C00h
Trace FIFO			4000_8C00h
PS-2	0		4000_9000h
GP-SPI	0		4000_9400h
GP-SPI	1		4000_9480h
Hibernation Timer	0		4000_9800h
Hibernation Timer	1		4000_9820h
Keyboard Matrix Scan			4000_9C00h
RPM2PWM	0		4000_A000h
RPM2PWM	1		4000_A080h
VBAT Register Bank			4000_A400h
VBAT Powered RAM			4000_A800h
Week Timer			4000_AC80h
VBAT-Powered Control Interface			4000_AE00h
Blinking-Breathing LED	0		4000_B800h
Blinking-Breathing LED	1		4000_B900h
Blinking-Breathing LED	2		4000_BA00h
Blinking-Breathing LED	3		4000_BB00h
BC-Link Master			4000_CD00h
Interrupt Aggregator			4000_E000h
EC Subsystem Registers			4000_FC00h
JTAG			4008_0000h
Power, Clocks and Resets (PCR)			4008_0100h
GPIOs			4008_1000h
Mailbox		0h	400F_0000h
8042 Emulated Keyboard Controller		1h	400F_0400h
ACPI EC Channel	0	2h	400F_0800h
ACPI EC Channel	1	3h	400F_0C00h
ACPI EC Channel	2	4h	400F_1000h
ACPI EC Channel	3	5h	400F_1400h
ACPI EC Channel	4	6h	400F_1800h
ACPI PM1		7h	400F_1C00h
Port 92-Legacy		8h	400F_2000h
UART	0	9h	400F_2400h
UART	1	Ah	400F_2800h
eSPI Interface IO Component		Dh	400F_3400h
eSPI Interface Memory Component		Eh	400F_3800h
Glue Logic	0	Fh	400F_3C00h

MEC1725

TABLE 3-1: BASE ADDRESS

Feature	Instance	Logical Device Number	Base Address
eSPI SAF Bridge Component	0		4000_8000h
eSPI SAF Communication Registers	0		4007_1000h
Embedded Memory Interface (EMI)	0	10h	400F_4000h
Embedded Memory Interface (EMI)	1	11h	400F_4400h
Embedded Memory Interface (EMI)	2	12h	400F_4800h
Real Time Clock		14h	400F_5000h
32 Bit BIOS Debug Port (Port 80)	0	20h	400F_8000h
32 Bit BIOS Debug Port (Port 80) Alias	0	21h	400F_8400h
eSPI Virtual Wires		27h	400F_9C00h
32Byte eSPI Test Block		2Fh	400F_BC00h
Global Configuration		3Fh	400F_FF00h
SPI Slave			4000_7000h
Environmental Monitor			4020_0600h

Note: The 32-Bit BIOS Debug Port contains two Logical Address register sets. The basic functionality supports 4 contiguous I/O bytes in the first ("Base") Logical Device register set (Logical Device 20h). One of these bytes can also be aliased to a non-contiguous I/O location, for legacy 16-bit Port 80 display handling, by using the separate "Alias" Logical Device register set (21h).

3.3 Sleep Enable Register Assignments

TABLE 3-2: SLEEP ALLOCATION

Block	Instance	Bit Position	Sleep Enable Register	Clock Required Register	Reset Enable Register
JTAG STAP		0	NA	Clock Required 0	NA
ISPI		2	NA	Clock Required 0	Reset Enable 0
Interrupt		0	Sleep Enable 1	Clock Required 1	Reset Enable 1
PECI		1	Sleep Enable 1	Clock Required 1	Reset Enable 1
Tach	0	2	Sleep Enable 1	Clock Required 1	Reset Enable 1
PWM	0	4	Sleep Enable 1	Clock Required 1	Reset Enable 1
PMC/PPP reg Bank		5	Sleep Enable 1	Clock Required 1	NA
DMA		6	Sleep Enable 1	Clock Required 1	Reset Enable 1
TFDP		7	Sleep Enable 1	Clock Required 1	Reset Enable 1
PROCESSOR		8	Sleep Enable 1	Clock Required 1	NA
WDT		9	NA	Clock Required 1	Reset Enable 1
SMB	0	10	Sleep Enable 1	Clock Required 1	Reset Enable 1
Tach	1	11	Sleep Enable 1	Clock Required 1	Reset Enable 1
Tach	2	12	Sleep Enable 1	Clock Required 1	Reset Enable 1
Tach	3	13	Sleep Enable 1	Clock Required 1	Reset Enable 1
PWM	1	20	Sleep Enable 1	Clock Required 1	Reset Enable 1
PWM	2	21	Sleep Enable 1	Clock Required 1	Reset Enable 1
PWM	3	22	Sleep Enable 1	Clock Required 1	Reset Enable 1
PWM	4	23	Sleep Enable 1	Clock Required 1	Reset Enable 1
PWM	5	24	Sleep Enable 1	Clock Required 1	Reset Enable 1
PWM	6	25	Sleep Enable 1	Clock Required 1	Reset Enable 1
PWM	7	26	Sleep Enable 1	Clock Required 1	Reset Enable 1
PWM	8	27	Sleep Enable 1	Clock Required 1	Reset Enable 1
EC Register Bank		29	Sleep Enable 1	Clock Required 1	NA
Basic Timer 16	0	30	Sleep Enable 1	Clock Required 1	Reset Enable 1
Basic Timer 16	1	31	Sleep Enable 1	Clock Required 1	Reset Enable 1
IMAP	0	0	NA	Clock Required 2	Reset Enable 2
UART	0	1	Sleep Enable 2	Clock Required 2	Reset Enable 2
UART	1	2	Sleep Enable 2	Clock Required 2	Reset Enable 2
Global Configuration		12	NA	Clock Required 2	NA
ACPI EC	0	13	NA	NA	Reset Enable 2
ACPI EC	1	14	NA	NA	Reset Enable 2
ACPI PM1		15	NA	NA	Reset Enable 2
8042 Emulation		16	NA	Clock Required 2	Reset Enable 2
Mailbox		17	NA	NA	Reset Enable 2
RTC		18	NA	Clock Required 2	NA
eSPI2AHB		19	Sleep Enable 2	Clock Required 2	NA
SCRATCH_32REGs		20	NA	NA	Reset Enable 2
ACPI EC	2	21	NA	Clock Required 2	Reset Enable 2
ACPI EC	3	22	NA	Clock Required 2	Reset Enable 2

MEC1725

TABLE 3-2: SLEEP ALLOCATION

Block	Instance	Bit Position	Sleep Enable Register	Clock Required Register	Reset Enable Register
ACPI EC	4	23	NA	Clock Required 2	Reset Enable 2
Port 80	0	25	NA	NA	Reset Enable 2
SAF_BRIDGE		27	NA	Clock Required 2	NA
Glue	0	29	Sleep Enable 2	Clock Required 2	NA
ADC		3	Sleep Enable 3	Clock Required 3	Reset Enable 3
PS2	0	5	Sleep Enable 3	Clock Required 3	Reset Enable 3
GP-SPI	0	9	Sleep Enable 3	Clock Required 3	Reset Enable 3
Hibernation Timer	0	10	Sleep Enable 3	Clock Required 3	Reset Enable 3
RPM2PWM	0	12	Sleep Enable 3	Clock Required 3	Reset Enable 3
SMB	1	13	Sleep Enable 3	Clock Required 3	Reset Enable 3
SMB	2	14	Sleep Enable 3	Clock Required 3	Reset Enable 3
SMB	3	15	Sleep Enable 3	Clock Required 3	Reset Enable 3
LED	0	16	Sleep Enable 3	Clock Required 3	Reset Enable 3
LED	1	17	Sleep Enable 3	Clock Required 3	Reset Enable 3
LED	2	18	Sleep Enable 3	Clock Required 3	Reset Enable 3
BC Master	0	19	Sleep Enable 3	Clock Required 3	Reset Enable 3
SMB	4	20	Sleep Enable 3	Clock Required 3	Reset Enable 3
Basic Timer 16	2	21	Sleep Enable 3	Clock Required 3	Reset Enable 3
Basic Timer 16	3	22	Sleep Enable 3	Clock Required 3	Reset Enable 3
Basic Timer 32	0	23	Sleep Enable 3	Clock Required 3	Reset Enable 3
Basic Timer 32	1	24	Sleep Enable 3	Clock Required 3	Reset Enable 3
LED	3	25	Sleep Enable 3	Clock Required 3	Reset Enable 3
Crypto		26	Sleep Enable 3	Clock Required 3	Reset Enable 3
Hibernation Timer	1	29	Sleep Enable 3	Clock Required 3	Reset Enable 3
CCT	0	30	Sleep Enable 3	Clock Required 3	Reset Enable 3
PWM	9	31	Sleep Enable 3	Clock Required 3	Reset Enable 3
PWM	10	0	Sleep Enable 4	Clock Required 4	Reset Enable 4
PWM	11	1	Sleep Enable 4	Clock Required 4	Reset Enable 4
16-bit Counter Timer	0	2	Sleep Enable 4	Clock Required 4	Reset Enable 4
16-bit Counter Timer	1	3	Sleep Enable 4	Clock Required 4	Reset Enable 4
16-bit Counter Timer	2	4	Sleep Enable 4	Clock Required 4	Reset Enable 4
16-bit Counter Timer	3	5	Sleep Enable 4	Clock Required 4	Reset Enable 4
RTOS Timer		6	NA	Clock Required 4	Reset Enable 4
RPM2PWM	1	7	Sleep Enable 4	Clock Required 4	Reset Enable 4
Quad SPI Master		8	Sleep Enable 4	Clock Required 4	Reset Enable 4
RC_ID	0	10	Sleep Enable 4	Clock Required 4	Reset Enable 4
RC_ID	1	11	Sleep Enable 4	Clock Required 4	Reset Enable 4
RC_ID	2	12	Sleep Enable 4	Clock Required 4	Reset Enable 4
PROCHOT	0	13	Sleep Enable 4	Clock Required 4	Reset Enable 4
PSPI	0	14	Sleep Enable 4	Clock Required 4	Reset Enable 4

3.4 Interrupt Aggregator Bit Assignments

TABLE 3-3: GPIO MAPPING

Agg IRQ	Agg Bits	HWB Instance Name	Interrupt Event	Wake event	Source description	Agg NVIC	Direct NVIC
GIRQ8	0	GPIO140	GPIO Event	Yes	GPIO Interrupt Event	0	N/A
	1	GPIO141	GPIO Event	Yes	GPIO Interrupt Event		
	2	GPIO142	GPIO Event	Yes	GPIO Interrupt Event		
	3	GPIO143	GPIO Event	Yes	GPIO Interrupt Event		
	4	GPIO144	GPIO Event	Yes	GPIO Interrupt Event		
	5	GPIO145	GPIO Event	Yes	GPIO Interrupt Event		
	6	GPIO146	GPIO Event	Yes	GPIO Interrupt Event		
	7	GPIO147	GPIO Event	Yes	GPIO Interrupt Event		
	8	GPIO150	GPIO Event	Yes	GPIO Interrupt Event		
	9	GPIO151	GPIO Event	Yes	GPIO Interrupt Event		
	10	GPIO152	GPIO Event	Yes	GPIO Interrupt Event		
	11	GPIO153	GPIO Event	Yes	GPIO Interrupt Event		
	12	GPIO154	GPIO Event	Yes	GPIO Interrupt Event		
	13	GPIO155	GPIO Event	Yes	GPIO Interrupt Event		
	14	GPIO156	GPIO Event	Yes	GPIO Interrupt Event		
	15	GPIO157	GPIO Event	Yes	GPIO Interrupt Event		
	16	GPIO160	GPIO Event	Yes	GPIO Interrupt Event		
	17	GPIO161	GPIO Event	Yes	GPIO Interrupt Event		
	18	GPIO162	GPIO Event	Yes	GPIO Interrupt Event		
	19-20	Reserved					
	21	GPIO165	GPIO Event	Yes	GPIO Interrupt Event		
	22	GPIO166	GPIO Event	Yes	GPIO Interrupt Event		
	23	Reserved					
	24	GPIO170	GPIO Event	Yes	GPIO Interrupt Event		
	25	GPIO171	GPIO Event	Yes	GPIO Interrupt Event		
	26	GPIO172	GPIO Event	Yes	GPIO Interrupt Event		
	29	GPIO175	GPIO Event	Yes	GPIO Interrupt Event		
	30	Reserved	-	-			
	31	Reserved	-	-			
GIRQ9	0	GPIO100	GPIO Event	Yes	GPIO Interrupt Event	1	N/A
	1	GPIO101	GPIO Event	Yes	GPIO Interrupt Event		
	2	GPIO102	GPIO Event	Yes	GPIO Interrupt Event		
	3	GPIO103	GPIO Event	Yes	GPIO Interrupt Event		
	4	GPIO104	GPIO Event	Yes	GPIO Interrupt Event		
	5	GPIO105	GPIO Event	Yes	GPIO Interrupt Event		
	6	GPIO106	GPIO Event	Yes	GPIO Interrupt Event		
	7	GPIO107	GPIO Event	Yes	GPIO Interrupt Event		
	8	GPIO110	GPIO Event	Yes	GPIO Interrupt Event		
	9	GPIO111	GPIO Event	Yes	GPIO Interrupt Event		
	10	GPIO112	GPIO Event	Yes	GPIO Interrupt Event		

MEC1725

TABLE 3-3: GPIO MAPPING

Agg IRQ	Agg Bits	HWB Instance Name	Interrupt Event	Wake event	Source description	Agg NVIC	Direct NVIC
	11	GPIO113	GPIO Event	Yes	GPIO Interrupt Event		
	12	GPIO114	GPIO Event	Yes	GPIO Interrupt Event		
	13	GPIO115	GPIO Event	Yes	GPIO Interrupt Event		
	15	GPIO117	GPIO Event	Yes	GPIO Interrupt Event		
	16	GPIO120	GPIO Event	Yes	GPIO Interrupt Event		
	17	GPIO121	GPIO Event	Yes	GPIO Interrupt Event		
	18	GPIO122	GPIO Event	Yes	GPIO Interrupt Event		
	19	GPIO123	GPIO Event	Yes	GPIO Interrupt Event		
	20	GPIO124	GPIO Event	Yes	GPIO Interrupt Event		
	21	GPIO125	GPIO Event	Yes	GPIO Interrupt Event		
	22	GPIO126	GPIO Event	Yes	GPIO Interrupt Event		
	23	GPIO127	GPIO Event	Yes	GPIO Interrupt Event		
	24	GPIO130	GPIO Event	Yes	GPIO Interrupt Event		
	25	GPIO131	GPIO Event	Yes	GPIO Interrupt Event		
	26	GPIO132	GPIO Event	Yes	GPIO Interrupt Event		
	27	GPIO133	GPIO Event	Yes	GPIO Interrupt Event		
	28	GPIO134	GPIO Event	Yes	GPIO Interrupt Event		
	29	GPIO135	GPIO Event	Yes	GPIO Interrupt Event		
	30	Reserved	-	-			
	31	Reserved	-	-			
GIRQ10	0	GPIO040	GPIO Event	Yes	GPIO Interrupt Event	2	N/A
	1	GPIO041	GPIO Event	Yes	GPIO Interrupt Event		
	2	GPIO042	GPIO Event	Yes	GPIO Interrupt Event		
	3	GPIO043	GPIO Event	Yes	GPIO Interrupt Event		
	4	GPIO044	GPIO Event	Yes	GPIO Interrupt Event		
	5	GPIO045	GPIO Event	Yes	GPIO Interrupt Event		
	6	GPIO046	GPIO Event	Yes	GPIO Interrupt Event		
	7	GPIO047	GPIO Event	Yes	GPIO Interrupt Event		
	8	GPIO050	GPIO Event	Yes	GPIO Interrupt Event		
	9	GPIO051	GPIO Event	Yes	GPIO Interrupt Event		
	10	GPIO052	GPIO Event	Yes	GPIO Interrupt Event		
	11	GPIO053	GPIO Event	Yes	GPIO Interrupt Event		
	12	GPIO054	GPIO Event	Yes	GPIO Interrupt Event		
	13	GPIO055	GPIO Event	Yes	GPIO Interrupt Event		
	14	GPIO056	GPIO Event	Yes	GPIO Interrupt Event		
	15	GPIO057	GPIO Event	Yes	GPIO Interrupt Event		
	16	GPIO060	GPIO Event	Yes	GPIO Interrupt Event		
	17	GPIO061	GPIO Event	Yes	GPIO Interrupt Event		
	19	GPIO063	GPIO Event	Yes	GPIO Interrupt Event		
	20	GPIO064	GPIO Event	Yes	GPIO Interrupt Event		
	21	GPIO065	GPIO Event	Yes	GPIO Interrupt Event		
	22	GPIO066	GPIO Event	Yes	GPIO Interrupt Event		
	23	GPIO067	GPIO Event	Yes	GPIO Interrupt Event		
	24	GPIO070	GPIO Event	Yes	GPIO Interrupt Event		

TABLE 3-3: GPIO MAPPING

Agg IRQ	Agg Bits	HWB Instance Name	Interrupt Event	Wake event	Source description	Agg NVIC	Direct NVIC
	25	GPIO071	GPIO Event	Yes	GPIO Interrupt Event		
	26	GPIO072	GPIO Event	Yes	GPIO Interrupt Event		
	27	GPIO073	GPIO Event	Yes	GPIO Interrupt Event		
	28	GPIO074	GPIO Event	Yes	GPIO Interrupt Event		
	29	GPIO075	GPIO Event	Yes	GPIO Interrupt Event		
	30	GPIO076	GPIO Event	Yes	GPIO Interrupt Event		
	31	Reserved	-	-			
GIRQ11	0	GPIO000	GPIO Event	Yes	GPIO Interrupt Event	3	N/A
	1	GPIO001	GPIO Event	Yes	GPIO Interrupt Event		
	2	GPIO002	GPIO Event	Yes	GPIO Interrupt Event		
	3	GPIO003	GPIO Event	Yes	GPIO Interrupt Event		
	4	GPIO004	GPIO Event	Yes	GPIO Interrupt Event		
	5	GPIO005	GPIO Event	Yes	GPIO Interrupt Event		
	6	GPIO006	GPIO Event	Yes	GPIO Interrupt Event		
	7	GPIO007	GPIO Event	Yes	GPIO Interrupt Event		
	8	GPIO010	GPIO Event	Yes	GPIO Interrupt Event		
	9	GPIO011	GPIO Event	Yes	GPIO Interrupt Event		
	10	GPIO012	GPIO Event	Yes	GPIO Interrupt Event		
	11	GPIO013	GPIO Event	Yes	GPIO Interrupt Event		
	12	GPIO014	GPIO Event	Yes	GPIO Interrupt Event		
	13	GPIO015	GPIO Event	Yes	GPIO Interrupt Event		
	14	GPIO016	GPIO Event	Yes	GPIO Interrupt Event		
	15	GPIO017	GPIO Event	Yes	GPIO Interrupt Event		
	16	GPIO020	GPIO Event	Yes	GPIO Interrupt Event		
	17	GPIO021	GPIO Event	Yes	GPIO Interrupt Event		
	18	GPIO022	GPIO Event	Yes	GPIO Interrupt Event		
	19	GPIO023	GPIO Event	Yes	GPIO Interrupt Event		
	20	GPIO024	GPIO Event	Yes	GPIO Interrupt Event		
	21	GPIO025	GPIO Event	Yes	GPIO Interrupt Event		
	22	GPIO026	GPIO Event	Yes	GPIO Interrupt Event		
	23	GPIO027	GPIO Event	Yes	GPIO Interrupt Event		
	24	GPIO030	GPIO Event	Yes	GPIO Interrupt Event		
	25	GPIO031	GPIO Event	Yes	GPIO Interrupt Event		
	26	GPIO032	GPIO Event	Yes	GPIO Interrupt Event		
	27	GPIO033	GPIO Event	Yes	GPIO Interrupt Event		
	28	GPIO034	GPIO Event	Yes	GPIO Interrupt Event		
	29	GPIO035	GPIO Event	Yes	GPIO Interrupt Event		
	30	GPIO036	GPIO Event	Yes	GPIO Interrupt Event		
	31	Reserved	-	-			
GIRQ12	0	GPIO200	GPIO Event	Yes	GPIO Interrupt Event	4	N/A
	1	GPIO201	GPIO Event	Yes	GPIO Interrupt Event		
	2	GPIO202	GPIO Event	Yes	GPIO Interrupt Event		
	3	GPIO203	GPIO Event	Yes	GPIO Interrupt Event		
	4	GPIO204	GPIO Event	Yes	GPIO Interrupt Event		

MEC1725

TABLE 3-3: GPIO MAPPING

Agg IRQ	Agg Bits	HWB Instance Name	Interrupt Event	Wake event	Source description	Agg NVIC	Direct NVIC
	5	GPIO205	GPIO Event	Yes	GPIO Interrupt Event		
	6	GPIO206	GPIO Event	Yes	GPIO Interrupt Event		
	7	GPIO207	GPIO Event	Yes	GPIO Interrupt Event		
	8	GPIO210	GPIO Event	Yes	GPIO Interrupt Event		
	9	GPIO211	GPIO Event	Yes	GPIO Interrupt Event		
	10	GPIO212	GPIO Event	Yes	GPIO Interrupt Event		
	11	GPIO213	GPIO Event	Yes	GPIO Interrupt Event		
	12	GPIO214	GPIO Event	Yes	GPIO Interrupt Event		
	13	GPIO215	GPIO Event	Yes	GPIO Interrupt Event		
	14	GPIO216	GPIO Event	Yes	GPIO Interrupt Event		
	15	GPIO217	GPIO Event	Yes	GPIO Interrupt Event		
	17	GPIO221	GPIO Event	Yes	GPIO Interrupt Event		
	18	GPIO222	GPIO Event	Yes	GPIO Interrupt Event		
	19	GPIO223	GPIO Event	Yes	GPIO Interrupt Event		
	20	GPIO224	GPIO Event	Yes	GPIO Interrupt Event		
	21	GPIO225	GPIO Event	Yes	GPIO Interrupt Event		
	22	GPIO226	GPIO Event	Yes	GPIO Interrupt Event		
	23	GPIO227	GPIO Event	Yes	GPIO Interrupt Event		
	24	GPIO230	GPIO Event	Yes	GPIO Interrupt Event		
	25	GPIO231	GPIO Event	Yes	GPIO Interrupt Event		
	27	GPIO233	GPIO Event	Yes	GPIO Interrupt Event		
	31	Reserved	-	-			
GIRQ13	0	SMB-I2C Controller0	SMB-I2C	No	SMB-I2C Controller 0 Interrupt Event	5	20
	1	SMB-I2C Controller1	SMB-I2C	No	SMB-I2C Controller 1 Interrupt Event		21
	2	SMB-I2C Controller2	SMB-I2C	No	SMB-I2C Controller 2 Interrupt Event		22
	3	SMB-I2C Controller3	SMB-I2C	No	SMB-I2C Controller 3 Interrupt Event		23
	4	SMB-I2C Controller4	SMB-I2C	No	SMB-I2C Controller 4 Interrupt Event		158
	5-31	Reserved	-	-			
GIRQ14	0	DMA Controller	DMA0	No	DMA Controller - Channel 0 Interrupt Event	6	24
	1	DMA Controller	DMA1	No	DMA Controller - Channel 1 Interrupt Event		25
	2	DMA Controller	DMA2	No	DMA Controller - Channel 2 Interrupt Event		26
	3	DMA Controller	DMA3	No	DMA Controller - Channel 3 Interrupt Event		27
	4	DMA Controller	DMA4	No	DMA Controller - Channel 4 Interrupt Event		28
	5	DMA Controller	DMA5	No	DMA Controller - Channel 5 Interrupt Event		29

TABLE 3-3: GPIO MAPPING

Agg IRQ	Agg Bits	HWB Instance Name	Interrupt Event	Wake event	Source description	Agg NVIC	Direct NVIC
	6	DMA Controller	DMA6	No	DMA Controller - Channel 6 Interrupt Event		30
	7	DMA Controller	DMA7	No	DMA Controller - Channel 7 Interrupt Event		31
	8	DMA Controller	DMA8	No	DMA Controller - Channel 8 Interrupt Event		32
	9	DMA Controller	DMA9	No	DMA Controller - Channel 9 Interrupt Event		33
	10	DMA Controller	DMA10	No	DMA Controller - Channel 10 Interrupt Event		34
	11	DMA Controller	DMA11	No	DMA Controller - Channel 11 Interrupt Event		35
	12	DMA Controller	DMA12	No	DMA Controller - Channel 12 Interrupt Event		36
	13	DMA Controller	DMA13	No	DMA Controller - Channel 13 Interrupt Event		37
	14	DMA Controller	DMA14	No	DMA Controller - Channel 11 Interrupt Event		38
	15	DMA Controller	DMA15	No	DMA Controller - Channel 12 Interrupt Event		39
	16-31	Reserved					
GIRQ15	0	UART 0	UART	No	UART Interrupt Event	7	40
	1	UART 1	UART	No	UART Interrupt Event		41
	2	EMI 0	Host-to-EC	No	Embedded Memory Interface 0 - Host-to-EC Interrupt		42
	3	EMI 1	Host-to-EC	No	Embedded Memory Interface 1 - Host-to-EC Interrupt		43
	4	EMI 2	Host-to-EC	No	Embedded Memory Interface 1 - Host-to-EC Interrupt		44
	5	ACPI EC Interface 0	IBF	No	ACPI EC Interface 0 - Input Buffer Full Event		45
	6	ACPI EC Interface 0	OBE	No	ACPI EC Interface 0 - Output Buffer Empty Event, asserted when OBE flag goes to 1		46
	7	ACPI EC Interface 1	IBF	No	ACPI EC Interface 1 - Input Buffer Full Event		47
	8	ACPI EC Interface 1	OBE	No	ACPI EC Interface 1 - Output Buffer Empty Event, asserted when OBE flag goes to 1		48
	9	ACPI EC Interface 2	IBF	No	ACPI EC Interface 2 - Input Buffer Full Event		49
	10	ACPI EC Interface 2	OBE	No	ACPI EC Interface 2 - Output Buffer Empty Event, asserted when OBE flag goes to 1		50
	11	ACPI EC Interface 3	IBF	No	ACPI EC Interface 3 - Input Buffer Full Event		51
	12	ACPI EC Interface 3	OBE	No	ACPI EC Interface 3 - Output Buffer Empty Event, asserted when OBE flag goes to 1		52

MEC1725

TABLE 3-3: GPIO MAPPING

Agg IRQ	Agg Bits	HWB Instance Name	Interrupt Event	Wake event	Source description	Agg NVIC	Direct NVIC
	13	ACPI EC Interface 4	IBF	No	ACPI EC Interface 4 - Input Buffer Full Event		53
	14	ACPI EC Interface 4	OBE	No	ACPI EC Interface 4 - Output Buffer Empty Event, asserted when OBE flag goes to 1		54
	15	ACPI_PM1	PM1_CTL	No	ACPI_PM1 Interface - PM1_CTL2 Interrupt Event		55
	16	ACPI_PM1	PM1_EN	No	ACPI_PM1 Interface - PM1_EN2 Interrupt Event		56
	17	ACPI_PM1	PM1_STS	No	ACPI_PM1 Interface - PM1_STS2 Interrupt Event		57
	18	8042 Keyboard	OBE	No	8042 Keyboard Controller - Output Buffer Empty Event, asserted when OBE flag goes to 1		58
	19	8042 Keyboard	IBF	No	8042 Keyboard Controller - Input Buffer Full Event		59
	20	Mailbox	MBX	No	Mailbox Interface - Host-to-EC Interrupt Event		60
	21	Reserved					
	22	32 bit Port 80 Debug 0	BDP_INT	No	Port 80h BIOS Debug Port Event		62
	24	Reserved		-	-		
	25-31	Reserved		-	-		
GIRQ16	0	Public Key Engine	PKE_INT	No	PKE Interrupt	8	65
	1	Reserved					
	2	Random Number Generator	TRNG_INT	No	TRNG completed processing		67
	3	AES-HASH	AES_HASH_INT	No	Interrupt from AES or SHA block		68
	4-31	Reserved					
GIRQ17	0	PECI	PECI_INT	No	PECI Host Event	9	70
	1	TACH 0	TACH	No	Tachometer 0 Interrupt Event		71
	2	TACH 1	TACH	No	Tachometer 1 Interrupt Event		72
	3	TACH 2	TACH	No	Tachometer 2 Interrupt Event		73
	4	TACH3	TACH	No	Tachometer 3 Interrupt Event		159
	5-7	Reserved	-	-			
	8	ADC Controller	ADC_Single_Int	No	ADC Controller - Single-Sample ADC Conversion Event		78
	9	ADC Controller	ADC_Repeat_Int	No	ADC Controller - Repeat-Sample ADC Conversion Event		79
	10	RC-ID0	RCID	No	0-1 transition of RC-ID done flag		80
	11	RC-ID1	RCID	No	0-1 transition of RC-ID done flag		81
	12	RC-ID2	RCID	No	0-1 transition of RC-ID done flag		82
	13	Breathing LED 0	PWM_WDT	No	Blinking LED 0 Watchdog Event		83
	14	Breathing LED 1	PWM_WDT	No	Blinking LED 1 Watchdog Event		84
	15	Breathing LED 2	PWM_WDT	No	Blinking LED 2 Watchdog Event		85

TABLE 3-3: GPIO MAPPING

Agg IRQ	Agg Bits	HWB Instance Name	Interrupt Event	Wake event	Source description	Agg NVIC	Direct NVIC
	16	Breathing LED 3	PWM_WDT	No	Blinking LED 3 Watchdog Event		86
	17	PROCHOT	PHOT	No	Prochot Monitor requires service		87
	18	PowerGuard 0	POWER-GUARD	No	A PowerGuard status bit is asserted		88
	19	PowerGuard 1	POWER-GUARD	No	A PowerGuard status bit is asserted		89
	20	RPM2PWM 0	FAN_FAIL	No	Failure to achieve target RPM		74
	21	RPM2PWM 0	FAN_STALL	No	Fan stall condition		75
	22	RPM2PWM 1	FAN_FAIL	No	Failure to achieve target RPM		76
	23	RPM2PWM 1	FAN_STALL	No	Fan stall condition		77
	24-31	Reserved	-	-			
GIRQ18	0	Reserved				10	
	1	Quad Master SPI Controller	QMSPI_INT	No	Master SPI Controller Requires Servicing		91
	2	GP-SPI 0	TXBE_STS	No	SPI TX buffer empty		92
	3	GP-SPI 0	RXBF_STS	No	SPI RX buffer full		93
	4	GP-SPI 1	TXBE_STS	No	SPI TX buffer empty		94
	5	GP-SPI 1	RXBF_STS	No	SPI RX buffer full		95
	6	BC-Link 0	BCM_BUSY_CLR	No	BC-Link Busy Clear Flag		97
	7	BC-Link 0	BCM_ERR	No	BC-Link Error Flag Interrupt		96
	8-9	Reserved	-	-			
	10	PS2 Interface 0	PS2_ACT	No	PS/2 Device Interface 0 - Activity Interrupt Event		100
	11-12	Reserved	-	-			
	13-19	Reserved					
	20	Capture Compare Timer	CAPTURE_TIMER	No	CCT Counter Event		146
	21	Capture Compare Timer	CAPTURE 0	No	CCT Capture 0 Event		147
	22	Capture Compare Timer	CAPTURE 1	No	CCT Capture 1 Event		148
	23	Capture Compare Timer	CAPTURE 2	No	CCT Capture 2 Event		149
	24	Capture Compare Timer	CAPTURE 3	No	CCT Capture 3 Event		150
	25	Capture Compare Timer	CAPTURE 4	No	CCT Capture 4 Event		151
	26	Capture Compare Timer	CAPTURE 5	No	CCT Capture 5 Event		152
	27	Capture Compare Timer	COMPARE 0	No	CCT Compare 0 Event		153
	28	Capture Compare Timer	COMPARE 1	No	CCT Compare 1 Event		154
	29-31	Reserved					
GIRQ19	0	eSPI_Slave	INTR_PC	No	Peripheral Channel Interrupt	11	103
	1	eSPI_Slave	INTR_BM1	No	Bus Mastering Channel 1 Interrupt		104

MEC1725

TABLE 3-3: GPIO MAPPING

Agg IRQ	Agg Bits	HWB Instance Name	Interrupt Event	Wake event	Source description	Agg NVIC	Direct NVIC
	2	eSPI_Slave	INTR_BM2	No	Bus Mastering Channel 2 Interrupt		105
	3	eSPI_Slave	INTR_LTR	No	Peripheral Message (LTR) Interrupt		106
	4	eSPI_Slave	INTR_OOB_UP	No	Out of Band Channel Up Interrupt		107
	5	eSPI_Slave	INTR_OOB_DOWN	No	Out of Band Channel Down Interrupt		108
	6	eSPI_Slave	INTR_FLASH	No	Flash Channel Interrupt		109
	7	eSPI_Slave	eSPI_RESET	No	eSPI_RESET		110
	8	eSPI_Slave	VWIRE_ENABLE	No	Virtual Wire Channel Enable Asserted		156
	9	SAF bidge EC	EC_CMPLTN	No	EC Completion Event-SAF mode		166
	10	SAF ESPI Err	ESPI_ERROR	No	ESPI Error Event-SAF mode		167
GIRQ19	11-31	Reserved					
GIRQ20	0-8	Test	Test	-	-	12	N/A
	0	STAP	STAP_OBF	No	Debug Output Buffer FIFO is Empty		N/A
	1	STAP	STAP_IBF	No	Debug Input Buffer FIFO is Full		
	2	STAP	STAP_WAKE	Yes	STAP Initiated Wake Event		
	3	OTP	READY_INTERRUPT	No	OTP ready interrupt		173
	4-7	Reserved					
	8	ISPI	ISPI_ERROR	No	ISPI Error		
	9	32KHz Clock Monitor	CLK_32KHZ_MONITOR	No	32KHz Clock Counter Monitor		174
	10-31	Reserved					
GIRQ21	0-1	Reserved				13	
	2	WDT	WDT_INT	Yes	Watch Dog Timer Interrupt		171
	3	Week Alarm	WEEK_ALARM_INT	Yes	Week Alarm Interrupt.		114
	4	Week Alarm	SUB_WEEK_ALARM_INT	Yes	Sub-Week Alarm Interrupt		115
	5	Week Alarm	ONE_SECOND	Yes	Week Alarm - One Second Interrupt		116
	6	Week Alarm	SUB_SECOND	Yes	Week Alarm - Sub-second Interrupt		117
	7	Week Alarm	SYS_PWR_PRESENT	Yes	System power present pin interrupt		118
	8	RTC	RTC	Yes	Real Time Clock Interrupt		119
	9	RTC	RTC_ALARM	Yes	Real Time Clock Alarm Interrupt		120
	10	VBAT-Powered Control Interface	VCI_OVRD_IN	Yes	VCI_OVRD_IN active high input pin interrupt		121

TABLE 3-3: GPIO MAPPING

Agg IRQ	Agg Bits	HWB Instance Name	Interrupt Event	Wake event	Source description	Agg NVIC	Direct NVIC
	11	VBAT-Powered Control Interface	VCI_IN0	Yes	VCI_IN0 Active-low Input Pin Interrupt		122
	12	VBAT-Powered Control Interface	VCI_IN1	Yes	VCI_IN1 Active-low Input Pin Interrupt		123
	13	VBAT-Powered Control Interface	VCI_IN2	Yes	VCI_IN2 Active-low Input Pin Interrupt		124
	14	VBAT-Powered Control Interface	VCI_IN3	Yes	VCI_IN3 Active-low Input Pin Interrupt		125
	16-17	Reserved					
	18	PS2 Port	PS2_0A_WK	Yes	PS2 Wake Event. Start bit detect.		129
	19	PS2 Port	PS2_0B_WK	Yes	PS2 Wake Event. Start bit detect.		130
	20-23	Reserved					
	24	Thermal Monitor Interface	ENVMON	Yes	Thermal Monitor Event		134
	25	Keyscan	KSC_INT	Yes	Keyboard Scan Interface Runtime Interrupt		135
	26	Glue		Yes	Glue logic PWRBTN# and Signal monitor interrupt		172
	2-31	Reserved					
GIRQ22	0	Reserved					
	1	SMB-I2C Controller0	SMB-I2C_WAKE_ONLY	Yes	Wake-Only Event (No Interrupt Generated) - SMB-I2C.0 START Detected		
	2	SMB-I2C Controller1	SMB-I2C_WAKE_ONLY	Yes	Wake-Only Event (No Interrupt Generated) - SMB-I2C.1 START Detected		
	3	SMB-I2C Controller2	SMB-I2C_WAKE_ONLY	Yes	Wake-Only Event (No Interrupt Generated) - SMB-I2C.2 START Detected		
	4	SMB-I2C Controller3	SMB-I2C_WAKE_ONLY	Yes	Wake-Only Event (No Interrupt Generated) - SMB-I2C.3 START Detected		
	5	SMB-I2C Controller4	SMB-I2C_WAKE_ONLY	Yes	Wake-Only Event (No Interrupt Generated) - SMB-I2C.4 START Detected		
	6-8	Reserved	-	-			
	9	ESPI Interface	ESPI_WAKE_ONLY	Yes	Wake-Only Event (No Interrupt Generated) - ESPI Traffic Detected		
	10-14	Reserved		-			
	15	STAP	STAP_WAKE	Yes	STAP Initiated Wake Event		
	16-31	Reserved		-			
GIRQ23	0	16-Bit Basic Timer 0	Timer_Event	No	Basic Timer Event	14	136
	1	16-Bit Basic Timer 1	Timer_Event	No	Basic Timer Event		137

MEC1725

TABLE 3-3: GPIO MAPPING

Agg IRQ	Agg Bits	HWB Instance Name	Interrupt Event	Wake event	Source description	Agg NVIC	Direct NVIC
	2	16-Bit Basic Timer 2	Timer_Event	No	Basic Timer Event		138
	3	16-Bit Basic Timer 3	Timer_Event	No	Basic Timer Event		139
	4	32-Bit Basic Timer 0	Timer_Event	No	Basic Timer Event		140
	5	32-Bit Basic Timer 1	Timer_Event	No	Basic Timer Event		141
	6	Counter/Timer 0	Timer_Event	No	16-bit Timer/Counter Event		142
	7	Counter/Timer 1	Timer_Event	No	16-bit Timer/Counter Event		143
	8	Counter/Timer 2	Timer_Event	No	16-bit Timer/Counter Event		144
	9	Counter/Timer 3	Timer_Event	No	16-bit Timer/Counter Event		145
	10	RTOS Timer	RTOS - TIMER	Yes	32-bit RTOS Timer Event		111
	11	RTOS Timer	SWI_0	No	Soft Interrupt request 0		
	12	RTOS Timer	SWI_1	No	Soft Interrupt request 1		
	13	RTOS Timer	SWI_2	No	Soft Interrupt request 2		
	14	RTOS Timer	SWI_3	No	Soft Interrupt request 3		
	15	Reserved					
	16	Hibernation Timer0	HTIMER	Yes	Hibernation Timer Event		112
	17	Hibernation Timer1	HTIMER	Yes	Hibernation Timer Event		113
	18-31	Reserved					
GIRQ24	0	eSPI_Slave	MSVW00_S RC0	Yes	M-to-S VW Interrupt Event	15	N/A
	1	eSPI_Slave	MSVW00_S RC1	Yes	M-to-S VW Interrupt Event		
	2	eSPI_Slave	MSVW00_S RC2	Yes	M-to-S VW Interrupt Event		
	3	eSPI_Slave	MSVW00_S RC3	Yes	M-to-S VW Interrupt Event		
	4	eSPI_Slave	MSVW01_S RC0	Yes	M-to-S VW Interrupt Event		
	5	eSPI_Slave	MSVW01_S RC1	Yes	M-to-S VW Interrupt Event		
	6	eSPI_Slave	MSVW01_S RC2	Yes	M-to-S VW Interrupt Event		
	7	eSPI_Slave	MSVW01_S RC3	Yes	M-to-S VW Interrupt Event		
	8	eSPI_Slave	MSVW02_S RC0	Yes	M-to-S VW Interrupt Event		
	9	eSPI_Slave	MSVW02_S RC1	Yes	M-to-S VW Interrupt Event		
	10	eSPI_Slave	MSVW02_S RC2	Yes	M-to-S VW Interrupt Event		
	11	eSPI_Slave	MSVW02_S RC3	Yes	M-to-S VW Interrupt Event		

TABLE 3-3: GPIO MAPPING

Agg IRQ	Agg Bits	HWB Instance Name	Interrupt Event	Wake event	Source description	Agg NVIC	Direct NVIC
	12	eSPI_Slave	MSVW03_S RC0	Yes	M-to-S VW Interrupt Event		
	13	eSPI_Slave	MSVW03_S RC1	Yes	M-to-S VW Interrupt Event		
	14	eSPI_Slave	MSVW03_S RC2	Yes	M-to-S VW Interrupt Event		
	15	eSPI_Slave	MSVW03_S RC3	Yes	M-to-S VW Interrupt Event		
	16	eSPI_Slave	MSVW04_S RC0	Yes	M-to-S VW Interrupt Event		
	17	eSPI_Slave	MSVW04_S RC1	Yes	M-to-S VW Interrupt Event		
	18	eSPI_Slave	MSVW04_S RC2	Yes	M-to-S VW Interrupt Event		
	19	eSPI_Slave	MSVW04_S RC3	Yes	M-to-S VW Interrupt Event		
	20	eSPI_Slave	MSVW05_S RC0	Yes	M-to-S VW Interrupt Event		
	21	eSPI_Slave	MSVW05_S RC1	Yes	M-to-S VW Interrupt Event		
	22	eSPI_Slave	MSVW05_S RC2	Yes	M-to-S VW Interrupt Event		
	23	eSPI_Slave	MSVW05_S RC3	Yes	M-to-S VW Interrupt Event		
	24	eSPI_Slave	MSVW06_S RC0	Yes	M-to-S VW Interrupt Event		
	25	eSPI_Slave	MSVW06_S RC1	Yes	M-to-S VW Interrupt Event		
	26	eSPI_Slave	MSVW06_S RC2	Yes	M-to-S VW Interrupt Event		
	27	eSPI_Slave	MSVW06_S RC3	Yes	M-to-S VW Interrupt Event		
	28-31	Reserved					
GIRQ25	0	eSPI_Slave	MSVW07_S RC0	Yes	M-to-S VW Interrupt Event	16	N/A
	1	eSPI_Slave	MSVW07_S RC1	Yes	M-to-S VW Interrupt Event		
	2	eSPI_Slave	MSVW07_S RC2	Yes	M-to-S VW Interrupt Event		
	3	eSPI_Slave	MSVW07_S RC3	Yes	M-to-S VW Interrupt Event		
	4	eSPI_Slave	MSVW08_S RC0	Yes	M-to-S VW Interrupt Event		
	5	eSPI_Slave	MSVW08_S RC1	Yes	M-to-S VW Interrupt Event		
	6	eSPI_Slave	MSVW08_S RC2	Yes	M-to-S VW Interrupt Event		
	7	eSPI_Slave	MSVW08_S RC3	Yes	M-to-S VW Interrupt Event		

MEC1725

TABLE 3-3: GPIO MAPPING

Agg IRQ	Agg Bits	HWB Instance Name	Interrupt Event	Wake event	Source description	Agg NVIC	Direct NVIC
	8	eSPI_Slave	MSVW09_S RC0	Yes	M-to-S VW Interrupt Event		
	9	eSPI_Slave	MSVW09_S RC1	Yes	M-to-S VW Interrupt Event		
	10	eSPI_Slave	MSVW09_S RC2	Yes	M-to-S VW Interrupt Event		
	11	eSPI_Slave	MSVW09_S RC3	Yes	M-to-S VW Interrupt Event		
	12	eSPI_Slave	MSVW10_S RC0	Yes	M-to-S VW Interrupt Event		
	13	eSPI_Slave	MSVW10_S RC1	Yes	M-to-S VW Interrupt Event		
	14	eSPI_Slave	MSVW10_S RC2	Yes	M-to-S VW Interrupt Event		
	15	eSPI_Slave	MSVW10_S RC3	Yes	M-to-S VW Interrupt Event		
	16-31	Reserved					
Direct NVIC Interrupts							
		ACPI EC Inter- face 0	ACPIEC _CMN_INT0				175
		ACPI EC Inter- face 1	ACPI EC_CMN_I NT1				176
		ACPI EC Inter- face 2	ACPIEC _CMN_INT2				177
		ACPI EC Inter- face 3	ACPIEC _CMN_INT3				178
		ACPI EC Inter- face 4	ACPI EC_CMN_I NT4				179
		ACPI_PM1	ACPIPM1 _CMN_INT				180

3.5 GPIO Register Assignments

All GPIOs except the below come up in default GPIO Input/output/interrupt disabled state. Pin control register defaults to 0x00008040.

TABLE 3-4: GPIO PIN CONTROL DEFAULT VALUES

GPIO	Pin Control Register Value	Default Function
GPIO000	0x00001040	VCI_IN, SYSPWR_PRES
GPIO161	0x00001040	VCI_IN
GPIO162	0x00001040	VCI_IN
GPIO234	0x00001040	VCI_IN
GPIO062	0x00008240	output
GPIO170	0x00000041	JTAG_STRAP BS (input, pull up)
GPIO116	0x00000041	input, pull up

MEC1725

3.6 Register Map

TABLE 3-5: REGISTER MAP

Block	Instance	Register	Host Type	Register Address
Watchdog Timer	0	WDT Load Register		40000400
Watchdog Timer	0	WDT Control Register		40000404
Watchdog Timer	0	WDT Kick Register		40000408
Watchdog Timer	0	WDT Count Register		4000040C
Watchdog Timer	0	WDT Status Register		40000410
Watchdog Timer	0	WDT Int Enable Register		40000414
16-bit Basic Timer	0	Timer Count Register		40000C00
16-bit Basic Timer	0	Timer Preload Register		40000C04
16-bit Basic Timer	0	Timer Status Register		40000C08
16-bit Basic Timer	0	Timer Int Enable Register		40000C0C
16-bit Basic Timer	0	Timer Control Register		40000C10
16-bit Basic Timer	1	Timer Count Register		40000C20
16-bit Basic Timer	1	Timer Preload Register		40000C24
16-bit Basic Timer	1	Timer Status Register		40000C28
16-bit Basic Timer	1	Timer Int Enable Register		40000C2C
16-bit Basic Timer	1	Timer Control Register		40000C30
16-bit Basic Timer	2	Timer Count Register		40000C40
16-bit Basic Timer	2	Timer Preload Register		40000C44
16-bit Basic Timer	2	Timer Status Register		40000C48
16-bit Basic Timer	2	Timer Int Enable Register		40000C4C
16-bit Basic Timer	2	Timer Control Register		40000C50
16-bit Basic Timer	3	Timer Count Register		40000C60
16-bit Basic Timer	3	Timer Preload Register		40000C64
16-bit Basic Timer	3	Timer Status Register		40000C68
16-bit Basic Timer	3	Timer Int Enable Register		40000C6C
16-bit Basic Timer	3	Timer Control Register		40000C70
32-bit Basic Timer	0	Timer Count Register		40000C80
32-bit Basic Timer	0	Timer Preload Register		40000C84
32-bit Basic Timer	0	Timer Status Register		40000C88
32-bit Basic Timer	0	Timer Int Enable Register		40000C8C
32-bit Basic Timer	0	Timer Control Register		40000C90
32-bit Basic Timer	1	Timer Count Register		40000CA0
32-bit Basic Timer	1	Timer Preload Register		40000CA4
32-bit Basic Timer	1	Timer Status Register		40000CA8
32-bit Basic Timer	1	Timer Int Enable Register		40000CAC
32-bit Basic Timer	1	Timer Control Register		40000CB0
16-bit Counter Timer	0	Timer x Control Register		40000D00
16-bit Counter Timer	0	Timer x Clock and Event Control Register		40000D04
16-bit Counter Timer	0	Timer x Reload Register		40000D08
16-bit Counter Timer	0	Timer x Count Register		40000D0C

TABLE 3-5: REGISTER MAP

Block	Instance	Register	Host Type	Register Address
16-bit Counter Timer	1	Timer x Control Register		4000D20
16-bit Counter Timer	1	Timer x Clock and Event Control Register		4000D24
16-bit Counter Timer	1	Timer x Reload Register		4000D28
16-bit Counter Timer	1	Timer x Count Register		4000D2C
16-bit Counter Timer	2	Timer x Control Register		4000D40
16-bit Counter Timer	2	Timer x Clock and Event Control Register		4000D44
16-bit Counter Timer	2	Timer x Reload Register		4000D48
16-bit Counter Timer	2	Timer x Count Register		4000D4C
16-bit Counter Timer	3	Timer x Control Register		4000D60
16-bit Counter Timer	3	Timer x Clock and Event Control Register		4000D64
16-bit Counter Timer	3	Timer x Reload Register		4000D68
16-bit Counter Timer	3	Timer x Count Register		4000D6C
Capture Compare Timer	0	Capture and Compare Timer Control Register		40001000
Capture Compare Timer	0	Capture Control 0 Register		40001004
Capture Compare Timer	0	Capture Control 1 Register		40001008
Capture Compare Timer	0	Free Running Timer Register		4000100C
Capture Compare Timer	0	Capture 0 Register		40001010
Capture Compare Timer	0	Capture 1 Register		40001014
Capture Compare Timer	0	Capture 2 Register		40001018
Capture Compare Timer	0	Capture 3 Register		4000101C
Capture Compare Timer	0	Capture 4 Register		40001020
Capture Compare Timer	0	Capture 5 Register		40001024
Capture Compare Timer	0	Compare 0 Register		40001028
Capture Compare Timer	0	Compare 1 Register		4000102C
Capture Compare Timer	0	ICT Mux Select Register		40001030
RC-ID	0	RC_ID Control Register		40001400
RC-ID	0	RC_ID Data Register		40001404
RC-ID	1	RC_ID Control Register		40001480
RC-ID	1	RC_ID Data Register		40001484
RC-ID	2	RC_ID Control Register		40001500
RC-ID	2	RC_ID Data Register		40001504
DMA Controller	0	DMA Main Control Register		40002400
DMA Controller	0	DMA Data Packet Register		40002404
DMA Controller	0	TEST		40002408
DMA Channel	0	DMA Channel N Activate Register		40002440
DMA Channel	0	DMA Channel N Memory Start Address Register		40002444
DMA Channel	0	DMA Channel N Memory End Address Register		40002448
DMA Channel	0	DMA Channel N Device Address		4000244C
DMA Channel	0	DMA Channel N Control Register		40002450
DMA Channel	0	DMA Channel N Interrupt Status Register		40002454
DMA Channel	0	DMA Channel N Interrupt Enable Register		40002458
DMA Channel	0	TEST		4000245C
DMA Channel	0	Channel N CRC Enable Register		40002460
DMA Channel	0	Channel N CRC Data Register		40002464

MEC1725

TABLE 3-5: REGISTER MAP

Block	Instance	Register	Host Type	Register Address
DMA Channel	0	Channel N CRC Post Status Register		40002468
DMA Channel	0	TEST		4000246C
DMA Channel	1	DMA Channel N Activate Register		40002480
DMA Channel	1	DMA Channel N Memory Start Address Register		40002484
DMA Channel	1	DMA Channel N Memory End Address Register		40002488
DMA Channel	1	DMA Channel N Device Address		4000248C
DMA Channel	1	DMA Channel N Control Register		40002490
DMA Channel	1	DMA Channel N Interrupt Status Register		40002494
DMA Channel	1	DMA Channel N Interrupt Enable Register		40002498
DMA Channel	1	TEST		4000249C
DMA Channel	1	Channel N Fill Enable Register		400024A0
DMA Channel	1	Channel N Fill Data Register		400024A4
DMA Channel	1	Channel N Fill Status Register		400024A8
DMA Channel	1	TEST		400024AC
DMA Channel	2	DMA Channel N Activate Register		400024C0
DMA Channel	2	DMA Channel N Memory Start Address Register		400024C4
DMA Channel	2	DMA Channel N Memory End Address Register		400024C8
DMA Channel	2	DMA Channel N Device Address		400024CC
DMA Channel	2	DMA Channel N Control Register		400024D0
DMA Channel	2	DMA Channel N Interrupt Status Register		400024D4
DMA Channel	2	DMA Channel N Interrupt Enable Register		400024D8
DMA Channel	2	TEST		400024DC
DMA Channel	3	DMA Channel N Activate Register		40002500
DMA Channel	3	DMA Channel N Memory Start Address Register		40002504
DMA Channel	3	DMA Channel N Memory End Address Register		40002508
DMA Channel	3	DMA Channel N Device Address		4000250C
DMA Channel	3	DMA Channel N Control Register		40002510
DMA Channel	3	DMA Channel N Interrupt Status Register		40002514
DMA Channel	3	DMA Channel N Interrupt Enable Register		40002518
DMA Channel	3	TEST		4000251C
DMA Channel	4	DMA Channel N Activate Register		40002540
DMA Channel	4	DMA Channel N Memory Start Address Register		40002544
DMA Channel	4	DMA Channel N Memory End Address Register		40002548
DMA Channel	4	DMA Channel N Device Address		4000254C
DMA Channel	4	DMA Channel N Control Register		40002550
DMA Channel	4	DMA Channel N Interrupt Status Register		40002554
DMA Channel	4	DMA Channel N Interrupt Enable Register		40002558
DMA Channel	4	TEST		4000255C
DMA Channel	5	DMA Channel N Activate Register		40002580
DMA Channel	5	DMA Channel N Memory Start Address Register		40002584
DMA Channel	5	DMA Channel N Memory End Address Register		40002588
DMA Channel	5	DMA Channel N Device Address		4000258C
DMA Channel	5	DMA Channel N Control Register		40002590
DMA Channel	5	DMA Channel N Interrupt Status Register		40002594

TABLE 3-5: REGISTER MAP

Block	Instance	Register	Host Type	Register Address
DMA Channel	5	DMA Channel N Interrupt Enable Register		40002598
DMA Channel	5	TEST		4000259C
DMA Channel	6	DMA Channel N Activate Register		400025C0
DMA Channel	6	DMA Channel N Memory Start Address Register		400025C4
DMA Channel	6	DMA Channel N Memory End Address Register		400025C8
DMA Channel	6	DMA Channel N Device Address		400025CC
DMA Channel	6	DMA Channel N Control Register		400025D0
DMA Channel	6	DMA Channel N Interrupt Status Register		400025D4
DMA Channel	6	DMA Channel N Interrupt Enable Register		400025D8
DMA Channel	6	TEST		400025DC
DMA Channel	7	DMA Channel N Activate Register		40002600
DMA Channel	7	DMA Channel N Memory Start Address Register		40002604
DMA Channel	7	DMA Channel N Memory End Address Register		40002608
DMA Channel	7	DMA Channel N Device Address		4000260C
DMA Channel	7	DMA Channel N Control Register		40002610
DMA Channel	7	DMA Channel N Interrupt Status Register		40002614
DMA Channel	7	DMA Channel N Interrupt Enable Register		40002618
DMA Channel	7	TEST		4000261C
DMA Channel	8	DMA Channel N Activate Register		40002640
DMA Channel	8	DMA Channel N Memory Start Address Register		40002644
DMA Channel	8	DMA Channel N Memory End Address Register		40002648
DMA Channel	8	DMA Channel N Device Address		4000264C
DMA Channel	8	DMA Channel N Control Register		40002650
DMA Channel	8	DMA Channel N Interrupt Status Register		40002654
DMA Channel	8	DMA Channel N Interrupt Enable Register		40002658
DMA Channel	8	TEST		4000265C
DMA Channel	9	DMA Channel N Activate Register		40002680
DMA Channel	9	DMA Channel N Memory Start Address Register		40002684
DMA Channel	9	DMA Channel N Memory End Address Register		40002688
DMA Channel	9	DMA Channel N Device Address		4000268C
DMA Channel	9	DMA Channel N Control Register		40002690
DMA Channel	9	DMA Channel N Interrupt Status Register		40002694
DMA Channel	9	DMA Channel N Interrupt Enable Register		40002698
DMA Channel	9	TEST		4000269C
DMA Channel	10	DMA Channel N Activate Register		400026C0
DMA Channel	10	DMA Channel N Memory Start Address Register		400026C4
DMA Channel	10	DMA Channel N Memory End Address Register		400026C8
DMA Channel	10	DMA Channel N Device Address		400026CC
DMA Channel	10	DMA Channel N Control Register		400026D0
DMA Channel	10	DMA Channel N Interrupt Status Register		400026D4
DMA Channel	10	DMA Channel N Interrupt Enable Register		400026D8
DMA Channel	10	TEST		400026DC
DMA Channel	11	DMA Channel N Activate Register		40002700
DMA Channel	11	DMA Channel N Memory Start Address Register		40002704

MEC1725

TABLE 3-5: REGISTER MAP

Block	Instance	Register	Host Type	Register Address
DMA Channel	11	DMA Channel N Memory End Address Register		40002708
DMA Channel	11	DMA Channel N Device Address		4000270C
DMA Channel	11	DMA Channel N Control Register		40002710
DMA Channel	11	DMA Channel N Interrupt Status Register		40002714
DMA Channel	11	DMA Channel N Interrupt Enable Register		40002718
DMA Channel	11	TEST		4000271C
DMA Channel	12	DMA Channel N Activate Register		40002740
DMA Channel	12	DMA Channel N Memory Start Address Register		40002744
DMA Channel	12	DMA Channel N Memory End Address Register		40002748
DMA Channel	12	DMA Channel N Device Address		4000274C
DMA Channel	12	DMA Channel N Control Register		40002750
DMA Channel	12	DMA Channel N Interrupt Status Register		40002754
DMA Channel	12	DMA Channel N Interrupt Enable Register		40002758
DMA Channel	12	TEST		4000275C
DMA Channel	13	DMA Channel N Activate Register		40002780
DMA Channel	13	DMA Channel N Memory Start Address Register		40002784
DMA Channel	13	DMA Channel N Memory End Address Register		40002788
DMA Channel	13	DMA Channel N Device Address		4000278C
DMA Channel	13	DMA Channel N Control Register		40002790
DMA Channel	13	DMA Channel N Interrupt Status Register		40002794
DMA Channel	13	DMA Channel N Interrupt Enable Register		40002798
DMA Channel	13	TEST		4000279C
DMA Channel	14	DMA Channel N Activate Register		400027C0
DMA Channel	14	DMA Channel N Memory Start Address Register		400027C4
DMA Channel	14	DMA Channel N Memory End Address Register		400027C8
DMA Channel	14	DMA Channel N Device Address		400027CC
DMA Channel	14	DMA Channel N Control Register		400027D0
DMA Channel	14	DMA Channel N Interrupt Status Register		400027D4
DMA Channel	14	DMA Channel N Interrupt Enable Register		400027D8
DMA Channel	14	TEST		400027DC
DMA Channel	15	DMA Channel N Activate Register		40002800
DMA Channel	15	DMA Channel N Memory Start Address Register		40002804
DMA Channel	15	DMA Channel N Memory End Address Register		40002808
DMA Channel	15	DMA Channel N Device Address		4000260C
DMA Channel	15	DMA Channel N Control Register		40002810
DMA Channel	15	DMA Channel N Interrupt Status Register		40002814
DMA Channel	15	DMA Channel N Interrupt Enable Register		40002818
DMA Channel	15	TEST		4000281C
PowerGuard	0	LPF1 Frequency Cut-off Rate Register		40003000
PowerGuard	0	LPF2 Frequency Cut-off Rate Register		40003004
PowerGuard	0	Data Register		40003008
PowerGuard	0	Threshold Limit Register		4000300C
PowerGuard	0	LOW_TIMER Register		40003010
PowerGuard	0	HIGH_TIMER Register		40003014

TABLE 3-5: REGISTER MAP

Block	Instance	Register	Host Type	Register Address
PowerGuard	0	Control And Status Register		40003018
PowerGuard	0	PowerGuard Interrupt Status Register		4000301C
PowerGuard	0	PowerGuard Interrupt Enable Register		40003020
PowerGuard	1	LPF1 Frequency Cut-off Rate Register		40003080
PowerGuard	1	LPF2 Frequency Cut-off Rate Register		40003084
PowerGuard	1	Data Register		40003088
PowerGuard	1	Threshold Limit Register		4000308C
PowerGuard	1	LOW_TIMER Register		40003090
PowerGuard	1	HIGH_TIMER Register		40003094
PowerGuard	1	Control And Status Register		40003098
PowerGuard	1	PowerGuard Interrupt Status Register		4000309C
PowerGuard	1	PowerGuard Interrupt Enable Register		400030A0
Prochot Monitor	0	PROCHOT Cumulative Count Register		40003400
Prochot Monitor	0	PROCHOT Duty Cycle Count Register		40003404
Prochot Monitor	0	PROCHOT Duty Cycle Period Register		40003408
Prochot Monitor	0	PROCHOT Status/Control Register		4000340C
Prochot Monitor	0	PROCHOT Assertion Counter Register		40003410
Prochot Monitor	0	PROCHOT Assertion Counter Limit Register		40003414
Prochot Monitor	0	TEST		40003418
I2C-SMB	0	Control Register		40004000
I2C-SMB	0	Status Register		40004000
I2C-SMB	0	Own Address Register		40004004
I2C-SMB	0	Data Register		40004008
I2C-SMB	0	Master Command Register		4000400C
I2C-SMB	0	Slave Command Register		40004010
I2C-SMB	0	PEC Register		40004014
I2C-SMB	0	Repeated START Hold Time Register		40004018
I2C-SMB	0	Completion Register		40004020
I2C-SMB	0	Idle Scaling Register		40004024
I2C-SMB	0	Configuration Register		40004028
I2C-SMB	0	Bus Clock Register		4000402C
I2C-SMB	0	Block ID Register		40004030
I2C-SMB	0	Revision Register		40004034
I2C-SMB	0	Bit-Bang Control Register		40004038
I2C-SMB	0	TEST		4000403C
I2C-SMB	0	Data Timing Register		40004040
I2C-SMB	0	Time-Out Scaling Register		40004044
I2C-SMB	0	Slave Transmit Buffer Register		40004048
I2C-SMB	0	Slave Receive Buffer Register		4000404C
I2C-SMB	0	Master Transmit Buffer Register		40004050
I2C-SMB	0	Master Receive Buffer Register		40004054
I2C-SMB	0	TEST		40004058
I2C-SMB	0	TEST		4000405C
I2C-SMB	0	Wake Status Register		40004060

MEC1725

TABLE 3-5: REGISTER MAP

Block	Instance	Register	Host Type	Register Address
I2C-SMB	0	Wake Enable Register		40004064
I2C-SMB	0	TEST		40004068
I2C-SMB	0	Slave address		4000406C
I2C-SMB	0	TEST		40004070
I2C-SMB	0	TEST		40004074
I2C-SMB	0	TEST		40004078
I2C-SMB	0	I2C Shadow Data		4000407C
I2C-SMB	1	Control Register		40004400
I2C-SMB	1	Status Register		40004400
I2C-SMB	1	Own Address Register		40004404
I2C-SMB	1	Data Register		40004408
I2C-SMB	1	Master Command Register		4000440C
I2C-SMB	1	Slave Command Register		40004410
I2C-SMB	1	PEC Register		40004414
I2C-SMB	1	Repeated START Hold Time Register		40004418
I2C-SMB	1	Completion Register		40004420
I2C-SMB	1	Idle Scaling Register		40004424
I2C-SMB	1	Configuration Register		40004428
I2C-SMB	1	Bus Clock Register		4000442C
I2C-SMB	1	Block ID Register		40004430
I2C-SMB	1	Revision Register		40004434
I2C-SMB	1	Bit-Bang Control Register		40004438
I2C-SMB	1	TEST		4000443C
I2C-SMB	1	Data Timing Register		40004440
I2C-SMB	1	Time-Out Scaling Register		40004444
I2C-SMB	1	Slave Transmit Buffer Register		40004448
I2C-SMB	1	Slave Receive Buffer Register		4000444C
I2C-SMB	1	Master Transmit Buffer Register		40004450
I2C-SMB	1	Master Receive Buffer Register		40004454
I2C-SMB	1	TEST		40004458
I2C-SMB	1	TEST		4000445C
I2C-SMB	1	Wake Status Register		40004460
I2C-SMB	1	Wake Enable Register		40004464
I2C-SMB	1	TEST		40004468
I2C-SMB	1	Slave address		4000446C
I2C-SMB	1	TEST		40004470
I2C-SMB	1	TEST		40004474
I2C-SMB	1	TEST		40004478
I2C-SMB	1	I2C Shadow Data Register		4000447C
I2C-SMB	2	Control Register		40004800
I2C-SMB	2	Status Register		40004800
I2C-SMB	2	Own Address Register		40004804
I2C-SMB	2	Data Register		40004808
I2C-SMB	2	Master Command Register		4000480C

TABLE 3-5: REGISTER MAP

Block	Instance	Register	Host Type	Register Address
I2C-SMB	2	Slave Command Register		40004810
I2C-SMB	2	PEC Register		40004814
I2C-SMB	2	Repeated START Hold Time Register		40004818
I2C-SMB	2	Completion Register		40004820
I2C-SMB	2	Idle Scaling Register		40004824
I2C-SMB	2	Configuration Register		40004828
I2C-SMB	2	Bus Clock Register		4000482C
I2C-SMB	2	Block ID Register		40004830
I2C-SMB	2	Revision Register		40004834
I2C-SMB	2	Bit-Bang Control Register		40004838
I2C-SMB	2	TEST		4000483C
I2C-SMB	2	Data Timing Register		40004840
I2C-SMB	2	Time-Out Scaling Register		40004844
I2C-SMB	2	Slave Transmit Buffer Register		40004848
I2C-SMB	2	Slave Receive Buffer Register		4000484C
I2C-SMB	2	Master Transmit Buffer Register		40004850
I2C-SMB	2	Master Receive Buffer Register		40004854
I2C-SMB	2	TEST		40004858
I2C-SMB	2	TEST		4000485C
I2C-SMB	2	Wake Status Register		40004860
I2C-SMB	2	Wake Enable Register		40004864
I2C-SMB	2	TEST		40004868
I2C-SMB	2	Slave address		4000486C
I2C-SMB	2	TEST		40004870
I2C-SMB	2	TEST		40004874
I2C-SMB	2	TEST		40004878
I2C-SMB	2	I2C Shadow Data Register		4000487C
I2C-SMB	3	Control Register		40004C00
I2C-SMB	3	Status Register		40004C00
I2C-SMB	3	Own Address Register		40004C04
I2C-SMB	3	Data Register		40004C08
I2C-SMB	3	Master Command Register		40004C0C
I2C-SMB	3	Slave Command Register		40004C10
I2C-SMB	3	PEC Register		40004C14
I2C-SMB	3	Repeated START Hold Time Register		40004C18
I2C-SMB	3	Completion Register		40004C20
I2C-SMB	3	Idle Scaling Register		40004C24
I2C-SMB	3	Configuration Register		40004C28
I2C-SMB	3	Bus Clock Register		40004C2C
I2C-SMB	3	Block ID Register		40004C30
I2C-SMB	3	Revision Register		40004C34
I2C-SMB	3	Bit-Bang Control Register		40004C38
I2C-SMB	3	TEST		40004C3C
I2C-SMB	3	Data Timing Register		40004C40

MEC1725

TABLE 3-5: REGISTER MAP

Block	Instance	Register	Host Type	Register Address
I2C-SMB	3	Time-Out Scaling Register		40004C44
I2C-SMB	3	Slave Transmit Buffer Register		40004C48
I2C-SMB	3	Slave Receive Buffer Register		40004C4C
I2C-SMB	3	Master Transmit Buffer Register		40004C50
I2C-SMB	3	Master Receive Buffer Register		40004C54
I2C-SMB	3	TEST		40004C58
I2C-SMB	3	TEST		40004C5C
I2C-SMB	3	Wake Status Register		40004C60
I2C-SMB	3	Wake Enable Register		40004C64
I2C-SMB	3	TEST		40004C68
I2C-SMB	3	Slave address		40004C6C
I2C-SMB	3	TEST		40004C70
I2C-SMB	3	TEST		40004C74
I2C-SMB	3	TEST		40004C78
I2C-SMB	3	I2C Shadow Data Register		40004C7C
I2C-SMB	4	Control Register		40005000
I2C-SMB	4	Status Register		40005000
I2C-SMB	4	Own Address Register		40005004
I2C-SMB	4	Data Register		40005008
I2C-SMB	4	Master Command Register		4000500C
I2C-SMB	4	Slave Command Register		40005010
I2C-SMB	4	PEC Register		40005014
I2C-SMB	4	Repeated START Hold Time Register		40005018
I2C-SMB	4	Completion Register		40005020
I2C-SMB	4	Idle Scaling Register		40005024
I2C-SMB	4	Configuration Register		40005028
I2C-SMB	4	Bus Clock Register		4000502C
I2C-SMB	4	Block ID Register		40005030
I2C-SMB	4	Revision Register		40005034
I2C-SMB	4	Bit-Bang Control Register		40005038
I2C-SMB	4	TEST		4000503C
I2C-SMB	4	Data Timing Register		40005040
I2C-SMB	4	Time-Out Scaling Register		40005044
I2C-SMB	4	Slave Transmit Buffer Register		40005048
I2C-SMB	4	Slave Receive Buffer Register		4000504C
I2C-SMB	4	Master Transmit Buffer Register		40005050
I2C-SMB	4	Master Receive Buffer Register		40005054
I2C-SMB	4	TEST		40005058
I2C-SMB	4	TEST		4000505C
I2C-SMB	4	Wake Status Register		40005060
I2C-SMB	4	Wake Enable Register		40005064
I2C-SMB	4	TEST		40005068
I2C-SMB	4	Slave address		4000506C
I2C-SMB	4	TEST		40005070

TABLE 3-5: REGISTER MAP

Block	Instance	Register	Host Type	Register Address
I2C-SMB	4	TEST		40005074
I2C-SMB	4	TEST		40005078
I2C-SMB	4	I2C Shadow Data Register		4000507C
QMSPI	0	QMSPI Mode Register		40070000
QMSPI	0	QMSPI Control Register		40070004
QMSPI	0	QMSPI Execute Register		40070008
QMSPI	0	QMSPI Interface Control Register		4007000C
QMSPI	0	QMSPI Status Register		40070010
QMSPI	0	QMSPI Buffer Count Status Register		40070014
QMSPI	0	QMSPI Interrupt Enable Register		40070018
QMSPI	0	QMSPI Buffer Count Trigger Register		4007001C
QMSPI	0	QMSPI Transmit Buffer Register		40070020
QMSPI	0	QMSPI Receive Buffer Register		40070024
QMSPI	0	QMSPI Chip Select Timing Register		40070028
QMSPI	0	QMSPI Description Buffer 0 Register		40070030
QMSPI	0	QMSPI Description Buffer 1 Register		40070034
QMSPI	0	QMSPI Description Buffer 2 Register		40070038
QMSPI	0	QMSPI Description Buffer 3 Register		4007003C
QMSPI	0	QMSPI Description Buffer 4 Register		40070040
QMSPI	0	QMSPI Description Buffer 5 Register		40070044
QMSPI	0	QMSPI Description Buffer 6 Register		40070048
QMSPI	0	QMSPI Description Buffer 7 Register		4007004C
QMSPI	0	QMSPI Description Buffer 8 Register		40070050
QMSPI	0	QMSPI Description Buffer 9 Register		40070054
QMSPI	0	QMSPI Description Buffer 10 Register		40070058
QMSPI	0	QMSPI Description Buffer 11 Register		4007005C
QMSPI	0	QMSPI Description Buffer 12 Register		40070060
QMSPI	0	QMSPI Description Buffer 13 Register		40070064
QMSPI	0	QMSPI Description Buffer 14 Register		40070068
QMSPI	0	QMSPI Description Buffer 15 Register		4007006C
QMSPI	0	QMSPI Alias Control Register		400700B0
QMSPI	0	QMSPI Mode Alternate1 Register		400700C0
QMSPI	0	QMSPI Local DMA RX Enable Register		40070100
QMSPI	0	QMSPI Local DMA TX Enable Register		40070104
QMSPI	0	QMSPI Local DMA RX Control 0 Register		40070110
QMSPI	0	QMSPI Local DMA RX Start Address 0 Register		40070114
QMSPI	0	QMSPI Local DMA RX Length 0 Register		40070118
QMSPI	0	RESERVED		4007011C
QMSPI	0	QMSPI Local DMA RX Control 1 Register		40070120
QMSPI	0	QMSPI Local DMA RX Start Address 1 Register		40070124
QMSPI	0	QMSPI Local DMA RX Length 1 Register		40070128
QMSPI	0	RESERVED		4007012C
QMSPI	0	QMSPI Local DMA RX Control 2 Register		40070130
QMSPI	0	QMSPI Local DMA RX Start Address 2 Register		40070134

MEC1725

TABLE 3-5: REGISTER MAP

Block	Instance	Register	Host Type	Register Address
QMSPI	0	QMSPI Local DMA RX Length 2 Register		40070138
QMSPI	0	RESERVED		4007013C
QMSPI	0	QMSPI Local DMA TX Control 0 Register		40070140
QMSPI	0	QMSPI Local DMA TX Start Address 0 Register		40070144
QMSPI	0	QMSPI Local DMA TX Length 0 Register		40070148
QMSPI	0	RESERVED		4007014C
QMSPI	0	QMSPI Local DMA TX Control 1 Register		40070150
QMSPI	0	QMSPI Local DMA TX Start Address 1 Register		40070154
QMSPI	0	QMSPI Local DMA TX Length 1 Register		40070158
QMSPI	0	RESERVED		4007015C
QMSPI	0	QMSPI Local DMA TX Control 2 Register		40070160
QMSPI	0	QMSPI Local DMA TX Start Address 2 Register		40070164
QMSPI	0	QMSPI Local DMA TX Length 2 Register		40070168
QMSPI	0	RESERVED		4007016C
16-bit PWM	0	PWMx Counter ON Time Register		40005800
16-bit PWM	0	PWMx Counter OFF Time Register		40005804
16-bit PWM	0	PWMx Configuration Register		40005808
16-bit PWM	0	TEST		4000580C
16-bit PWM	1	PWMx Counter ON Time Register		40005810
16-bit PWM	1	PWMx Counter OFF Time Register		40005814
16-bit PWM	1	PWMx Configuration Register		40005818
16-bit PWM	1	TEST		4000581C
16-bit PWM	2	PWMx Counter ON Time Register		40005820
16-bit PWM	2	PWMx Counter OFF Time Register		40005824
16-bit PWM	2	PWMx Configuration Register		40005828
16-bit PWM	2	TEST		4000582C
16-bit PWM	3	PWMx Counter ON Time Register		40005830
16-bit PWM	3	PWMx Counter OFF Time Register		40005834
16-bit PWM	3	PWMx Configuration Register		40005838
16-bit PWM	3	TEST		4000583C
16-bit PWM	4	PWMx Counter ON Time Register		40005840
16-bit PWM	4	PWMx Counter OFF Time Register		40005844
16-bit PWM	4	PWMx Configuration Register		40005848
16-bit PWM	4	TEST		4000584C
16-bit PWM	5	PWMx Counter ON Time Register		40005850
16-bit PWM	5	PWMx Counter OFF Time Register		40005854
16-bit PWM	5	PWMx Configuration Register		40005858
16-bit PWM	5	TEST		4000585C
16-bit PWM	6	PWMx Counter ON Time Register		40005860
16-bit PWM	6	PWMx Counter OFF Time Register		40005864
16-bit PWM	6	PWMx Configuration Register		40005868
16-bit PWM	6	TEST		4000586C
16-bit PWM	7	PWMx Counter ON Time Register		40005870
16-bit PWM	7	PWMx Counter OFF Time Register		40005874

TABLE 3-5: REGISTER MAP

Block	Instance	Register	Host Type	Register Address
16-bit PWM	7	PWMx Configuration Register		40005878
16-bit PWM	7	TEST		4000587C
16-bit PWM	8	PWMx Counter ON Time Register		40005880
16-bit PWM	8	PWMx Counter OFF Time Register		40005884
16-bit PWM	8	PWMx Configuration Register		40005888
16-bit PWM	8	TEST		4000588C
16-bit PWM	9	PWMx Counter ON Time Register		40005890
16-bit PWM	9	PWMx Counter OFF Time Register		40005894
16-bit PWM	9	PWMx Configuration Register		40005898
16-bit PWM	9	TEST		4000589C
16-bit PWM	10	PWMx Counter ON Time Register		400058A0
16-bit PWM	10	PWMx Counter OFF Time Register		400058A4
16-bit PWM	10	PWMx Configuration Register		400058A8
16-bit PWM	10	TEST		400058AC
16-bit PWM	11	PWMx Counter ON Time Register		400058B0
16-bit PWM	11	PWMx Counter OFF Time Register		400058B4
16-bit PWM	11	PWMx Configuration Register		400058B8
16-bit PWM	11	TEST		400058BC
16-bit Tach	0	TACHx Control Register		40006000
16-bit Tach	0	TACHx Status Register		40006004
16-bit Tach	0	TACHx High Limit Register		40006008
16-bit Tach	0	TACHx Low Limit Register		4000600C
16-bit Tach	1	TACHx Control Register		40006010
16-bit Tach	1	TACHx Status Register		40006014
16-bit Tach	1	TACHx High Limit Register		40006018
16-bit Tach	1	TACHx Low Limit Register		4000601C
16-bit Tach	2	TACHx Control Register		40006020
16-bit Tach	2	TACHx Status Register		40006024
16-bit Tach	2	TACHx High Limit Register		40006028
16-bit Tach	2	TACHx Low Limit Register		4000602C
16-bit Tach	3	TACHx Control Register		40006030
16-bit Tach	3	TACHx Status Register		40006034
16-bit Tach	3	TACHx High Limit Register		40006038
16-bit Tach	3	TACHx Low Limit Register		4000603C
PECI	0	Write Data Register		40006400
PECI	0	Read Data Register		40006404
PECI	0	Control Register		40006408
PECI	0	Status Register 1		4000640C
PECI	0	Status Register 2		40006410
PECI	0	Error Register		40006414
PECI	0	Interrupt Enable 1 Register		40006418
PECI	0	Interrupt Enable 2 Register		4000641C
PECI	0	Optimal Bit Time Register (Low Byte)		40006420
PECI	0	Optimal Bit Time Register (High Byte)		40006424

MEC1725

TABLE 3-5: REGISTER MAP

Block	Instance	Register	Host Type	Register Address
PECI	0	TEST		40006428
PECI	0	TEST		4000642C
PECI	0	BAUD_CTRL		40006430
PECI	0	Block ID Register		40006440
PECI	0	Revision Register		40006444
RTOS Timer	0	RTOS Timer Count Register		40007400
RTOS Timer	0	RTOS Timer Preload Register		40007404
RTOS Timer	0	RTOS Timer Control Register		40007408
RTOS Timer	0	Soft Interrupt Register		4000740C
ADC	0	ADC Control Register		40007C00
ADC	0	ADC Delay Register		40007C04
ADC	0	ADC Status Register		40007C08
ADC	0	ADC Single Register		40007C0C
ADC	0	ADC Repeat Register		40007C10
ADC	0	ADC Channel 0 Reading Register		40007C14
ADC	0	ADC Channel 1 Reading Register		40007C18
ADC	0	ADC Channel 2 Reading Register		40007C1C
ADC	0	ADC Channel 3 Reading Register		40007C20
ADC	0	ADC Channel 4 Reading Register		40007C24
ADC	0	ADC Channel 5 Reading Register		40007C28
ADC	0	ADC Channel 6 Reading Register		40007C2C
ADC	0	ADC Channel 7 Reading Register		40007C30
ADC	0	ADC Channel 8 Reading Register		40007C34
ADC	0	ADC Channel 9 Reading Register		40007C38
ADC	0	ADC Channel 10 Reading Register		40007C3C
ADC	0	ADC Channel 11 Reading Register		40007C40
ADC	0	ADC Channel 12 Reading Register		40007C44
ADC	0	ADC Channel 13 Reading Register		40007C48
ADC	0	ADC Channel 14 Reading Register		40007C4C
ADC	0	ADC Channel 15 Reading Register		40007C50
ADC	0	ADC Configuration Register		40007C7C
ADC	0	VREF Channel Register		40007C80
ADC	0	VREF Control Register		40007C84
ADC	0	SAR ADC Control Register		40007C88
ADC	0	SAR ADC Config Register		40007C8C
TFDP	0	Debug Data Register		40008C00
TFDP	0	Debug Control Register		40008C04
PS2	0	PS2 Transmit Buffer Register		40009000
PS2	0	PS2 Receive Buffer Register		40009000
PS2	0	PS2 Control Register		40009004
PS2	0	PS2 Status Register		40009008
GP-SPI	0	SPI Enable Register		40009400
GP-SPI	0	SPI Control Register		40009404
GP-SPI	0	SPI Status Register		40009408

TABLE 3-5: REGISTER MAP

Block	Instance	Register	Host Type	Register Address
GP-SPI	0	SPI TX_Data Register		4000940C
GP-SPI	0	SPI RX_Data Register		40009410
GP-SPI	0	SPI Clock Control Register		40009414
GP-SPI	0	SPI Clock Generator Register		40009418
GP-SPI	0	TESET		40009420
GP-SPI	1	SPI Enable Register		40009480
GP-SPI	1	SPI Control Register		40009484
GP-SPI	1	SPI Status Register		40009488
GP-SPI	1	SPI TX_Data Register		4000948C
GP-SPI	1	SPI RX_Data Register		40009490
GP-SPI	1	SPI Clock Control Register		40009494
GP-SPI	1	SPI Clock Generator Register		40009498
GP-SPI	1	TESET		400094A0
Hibernation Timer	0	HTimer Preload Register		40009800
Hibernation Timer	0	HTimer Control Register		40009804
Hibernation Timer	0	HTimer Count Register		40009808
Hibernation Timer	1	HTimer Preload Register		40009820
Hibernation Timer	1	HTimer Control Register		40009824
Hibernation Timer	1	HTimer Count Register		40009828
RPM2PWM	0	Fan Setting Register		4000A000
RPM2PWM	0	Fan Configuration 1 Register		4000A002
RPM2PWM	0	Fan Configuration 2 Register		4000A003
RPM2PWM	0	PWM Divide Register		4000A004
RPM2PWM	0	Gain Register		4000A005
RPM2PWM	0	Fan Spin Up Configuration Register		4000A006
RPM2PWM	0	Fan Step Register		4000A007
RPM2PWM	0	Fan Minimum Drive Register		4000A008
RPM2PWM	0	Valid TACH Count Register		4000A009
RPM2PWM	0	Fan Drive Fail Band Register		4000A00A
RPM2PWM	0	TACH Target Register		4000A00C
RPM2PWM	0	TACH Reading Register		4000A00E
RPM2PWM	0	PWM Driver Base Frequency Register		4000A010
RPM2PWM	0	Fan Status Register		4000A011
RPM2PWM	0	TEST		4000A012
RPM2PWM	0	TEST		4000A014
RPM2PWM	0	TEST		4000A015
RPM2PWM	0	TEST		4000A016
RPM2PWM	0	TEST		4000A017
RPM2PWM	1	Fan Setting Register		4000A080
RPM2PWM	1	PWM Divide Register		4000A081
RPM2PWM	1	Fan Configuration 1 Register		4000A082
RPM2PWM	1	Fan Configuration 2 Register		4000A083
RPM2PWM	1	Reserved		4000A084
RPM2PWM	1	Gain Register		4000A085

MEC1725

TABLE 3-5: REGISTER MAP

Block	Instance	Register	Host Type	Register Address
RPM2PWM	1	Fan Spin Up Configuration Register		4000A086
RPM2PWM	1	Fan Step Register		4000A087
RPM2PWM	1	Fan Minimum Drive Register		4000A088
RPM2PWM	1	Valid TACH Count Register		4000A089
RPM2PWM	1	Fan Drive Fail Band Register		4000A08A
RPM2PWM	1	TACH Target Register		4000A08C
RPM2PWM	1	TACH Reading Register		4000A08E
RPM2PWM	1	PWM Driver Base Frequency Register		4000A090
RPM2PWM	1	Fan Status Register		4000A091
RPM2PWM	1	TEST		4000A092
RPM2PWM	1	TEST		4000A094
RPM2PWM	1	TEST		4000A095
RPM2PWM	1	TEST		4000A096
RPM2PWM	1	TEST		4000A097
VBAT Register Bank	0	Power-Fail and Reset Status Register		4000A400
VBAT Register Bank	0	TEST		4000A404
VBAT Register Bank	0	Clock Enable Register		4000A408
VBAT Register Bank	0	TEST		4000A40C
VBAT Register Bank	0	TEST		4000A410
VBAT Register Bank	0	TEST		4000A414
VBAT Register Bank	0	TEST		4000A41C
VBAT Register Bank	0	Monotonic Counter Register		4000A420
VBAT Register Bank	0	Counter HiWord Register		4000A424
VBAT Register Bank	0	TEST		4000A428
VBAT Register Bank	0	TEST		4000A42C
VBAT Register Bank	0	Embedded Reset De-bounce Enable Register		4000A434
VBAT Powered RAM	0	Registers		4000A800
Week Timer	0	Control Register		4000AC80
Week Timer	0	Week Alarm Counter Register		4000AC84
Week Timer	0	Week Timer Compare Register		4000AC88
Week Timer	0	Clock Divider Register		4000AC8C
Week Timer	0	Sub-Second Programmable Interrupt Select Register		4000AC90
Week Timer	0	Sub-Week Control Register		4000AC94
Week Timer	0	Sub-Week Alarm Counter Register		4000AC98
Week Timer	0	BGPO Data Register		4000AC9C
Week Timer	0	BGPO Power Register		4000ACA0
Week Timer	0	BGPO Reset Register		4000ACA4
VBAT-Powered Control Interface	0	VCI Register		4000AE00
VBAT-Powered Control Interface	0	Latch Enable Register		4000AE04
VBAT-Powered Control Interface	0	Latch Resets Register		4000AE08

TABLE 3-5: REGISTER MAP

Block	Instance	Register	Host Type	Register Address
VBAT-Powered Control Interface	0	VCI Input Enable Register		4000AE0C
VBAT-Powered Control Interface	0	Holdoff Count Register		4000AE10
VBAT-Powered Control Interface	0	VCI Polarity Register		4000AE14
VBAT-Powered Control Interface	0	VCI Posedge Detect Register		4000AE18
VBAT-Powered Control Interface	0	VCI Negedge Detect Register		4000AE1C
VBAT-Powered Control Interface	0	VCI Buffer Enable Register		4000AE20
Blinking-Breathing PWM	0	LED Configuration Register		4000B800
Blinking-Breathing PWM	0	LED Limits Register		4000B804
Blinking-Breathing PWM	0	LED Delay Register		4000B808
Blinking-Breathing PWM	0	LED Update Stepsize Register		4000B80C
Blinking-Breathing PWM	0	LED Update Interval Register		4000B810
Blinking-Breathing PWM	0	LED Output Delay		4000B814
Blinking-Breathing PWM	1	LED Configuration Register		4000B900
Blinking-Breathing PWM	1	LED Limits Register		4000B904
Blinking-Breathing PWM	1	LED Delay Register		4000B908
Blinking-Breathing PWM	1	LED Update Stepsize Register		4000B90C
Blinking-Breathing PWM	1	LED Update Interval Register		4000B910
Blinking-Breathing PWM	1	LED Output Delay		4000B914
Blinking-Breathing PWM	2	LED Configuration Register		4000BA00
Blinking-Breathing PWM	2	LED Limits Register		4000BA04
Blinking-Breathing PWM	2	LED Delay Register		4000BA08
Blinking-Breathing PWM	2	LED Update Stepsize Register		4000BA0C
Blinking-Breathing PWM	2	LED Update Interval Register		4000BA10
Blinking-Breathing PWM	2	LED Output Delay		4000BA14
Blinking-Breathing PWM	3	LED Configuration Register		4000BB00
Blinking-Breathing PWM	3	LED Limits Register		4000BB04
Blinking-Breathing PWM	3	LED Delay Register		4000BB08
Blinking-Breathing PWM	3	LED Update Stepsize Register		4000BB0C
Blinking-Breathing PWM	3	LED Update Interval Register		4000BB10
Blinking-Breathing PWM	3	LED Output Delay		4000BB14
BC-Link Master	0	BC-Link Status Register		4000CD00h
BC-Link Master	0	BC-Link Address Register		4000CD04h
BC-Link Master	0	BC-Link Data Register		4000CD08h
BC-Link Master	0	BC-Link Clock Select Register		4000CD0Ch
Interrupt Aggregator	0	GIRQ8 Source Register		4000E000
Interrupt Aggregator	0	GIRQ8 Enable Set Register		4000E004
Interrupt Aggregator	0	GIRQ8 Result Register		4000E008
Interrupt Aggregator	0	GIRQ8 Enable Clear Register		4000E00C
Interrupt Aggregator	0	GIRQ9 Source Register		4000E014

MEC1725

TABLE 3-5: REGISTER MAP

Block	Instance	Register	Host Type	Register Address
Interrupt Aggregator	0	GIRQ9 Enable Set Register		4000E018
Interrupt Aggregator	0	GIRQ9 Result Register		4000E01C
Interrupt Aggregator	0	GIRQ9 Enable Clear Register		4000E020
Interrupt Aggregator	0	GIRQ10 Source Register		4000E028
Interrupt Aggregator	0	GIRQ10 Enable Set Register		4000E02C
Interrupt Aggregator	0	GIRQ10 Result Register		4000E030
Interrupt Aggregator	0	GIRQ10 Enable Clear Register		4000E034
Interrupt Aggregator	0	GIRQ11 Source Register		4000E03C
Interrupt Aggregator	0	GIRQ11 Enable Set Register		4000E040
Interrupt Aggregator	0	GIRQ11 Result Register		4000E044
Interrupt Aggregator	0	GIRQ11 Enable Clear Register		4000E048
Interrupt Aggregator	0	GIRQ12 Source Register		4000E050
Interrupt Aggregator	0	GIRQ12 Enable Set Register		4000E054
Interrupt Aggregator	0	GIRQ12 Result Register		4000E058
Interrupt Aggregator	0	GIRQ12 Enable Clear Register		4000E05C
Interrupt Aggregator	0	GIRQ13 Source Register		4000E064
Interrupt Aggregator	0	GIRQ13 Enable Set Register		4000E068
Interrupt Aggregator	0	GIRQ13 Result Register		4000E06C
Interrupt Aggregator	0	GIRQ13 Enable Clear Register		4000E070
Interrupt Aggregator	0	GIRQ14 Source Register		4000E078
Interrupt Aggregator	0	GIRQ14 Enable Set Register		4000E07C
Interrupt Aggregator	0	GIRQ14 Result Register		4000E080
Interrupt Aggregator	0	GIRQ14 Enable Clear Register		4000E084
Interrupt Aggregator	0	GIRQ15 Source Register		4000E08C
Interrupt Aggregator	0	GIRQ15 Enable Set Register		4000E090
Interrupt Aggregator	0	GIRQ15 Result Register		4000E094
Interrupt Aggregator	0	GIRQ15 Enable Clear Register		4000E098
Interrupt Aggregator	0	GIRQ16 Source Register		4000E0A0
Interrupt Aggregator	0	GIRQ16 Enable Set Register		4000E0A4
Interrupt Aggregator	0	GIRQ16 Result Register		4000E0A8
Interrupt Aggregator	0	GIRQ16 Enable Clear Register		4000E0AC
Interrupt Aggregator	0	GIRQ17 Source Register		4000E0B4
Interrupt Aggregator	0	GIRQ17 Enable Set Register		4000E0B8
Interrupt Aggregator	0	GIRQ17 Result Register		4000E0BC
Interrupt Aggregator	0	GIRQ17 Enable Clear Register		4000E0C0
Interrupt Aggregator	0	GIRQ18 Source Register		4000E0C8
Interrupt Aggregator	0	GIRQ18 Enable Set Register		4000E0CC
Interrupt Aggregator	0	GIRQ18 Result Register		4000E0D0
Interrupt Aggregator	0	GIRQ18 Enable Clear Register		4000E0D4
Interrupt Aggregator	0	GIRQ19 Source Register		4000E0DC
Interrupt Aggregator	0	GIRQ19 Enable Set Register		4000E0E0
Interrupt Aggregator	0	GIRQ19 Result Register		4000E0E4
Interrupt Aggregator	0	GIRQ19 Enable Clear Register		4000E0E8
Interrupt Aggregator	0	GIRQ20 Source Register		4000E0F0

TABLE 3-5: REGISTER MAP

Block	Instance	Register	Host Type	Register Address
Interrupt Aggregator	0	GIRQ20 Enable Set Register		4000E0F4
Interrupt Aggregator	0	GIRQ20 Result Register		4000E0F8
Interrupt Aggregator	0	GIRQ20 Enable Clear Register		4000E0FC
Interrupt Aggregator	0	GIRQ21 Source Register		4000E104
Interrupt Aggregator	0	GIRQ21 Enable Set Register		4000E108
Interrupt Aggregator	0	GIRQ21 Result Register		4000E10C
Interrupt Aggregator	0	GIRQ21 Enable Clear Register		4000E110
Interrupt Aggregator	0	GIRQ22 Source Register		4000E118
Interrupt Aggregator	0	GIRQ22 Enable Set Register		4000E11C
Interrupt Aggregator	0	GIRQ22 Result Register		4000E120
Interrupt Aggregator	0	GIRQ22 Enable Clear Register		4000E124
Interrupt Aggregator	0	GIRQ23 Source Register		4000E12C
Interrupt Aggregator	0	GIRQ23 Enable Set Register		4000E130
Interrupt Aggregator	0	GIRQ23 Result Register		4000E134
Interrupt Aggregator	0	GIRQ23 Enable Clear Register		4000E138
Interrupt Aggregator	0	GIRQ24 Source Register		4000E140
Interrupt Aggregator	0	GIRQ24 Enable Set Register		4000E144
Interrupt Aggregator	0	GIRQ24 Result Register		4000E148
Interrupt Aggregator	0	GIRQ24 Enable Clear Register		4000E14C
Interrupt Aggregator	0	GIRQ25 Source Register		4000E154
Interrupt Aggregator	0	GIRQ25 Enable Set Register		4000E158
Interrupt Aggregator	0	GIRQ25 Result Register		4000E15C
Interrupt Aggregator	0	GIRQ25 Enable Clear Register		4000E160
Interrupt Aggregator	0	GIRQ26 Source Register		4000E168
Interrupt Aggregator	0	GIRQ26 Enable Set Register		4000E16C
Interrupt Aggregator	0	GIRQ26 Result Register		4000E170
Interrupt Aggregator	0	GIRQ26 Enable Clear Register		4000E174
Interrupt Aggregator	0	Block Enable Set Register		4000E200
Interrupt Aggregator	0	Block Enable Clear Register		4000E204
Interrupt Aggregator	0	Block IRQ Vector Register		4000E208
EC Register Bank	0	TEST		4000FC00
EC Register Bank	0	AHB Error Address Register		4000FC04
EC Register Bank	0	TEST		4000FC08
EC Register Bank	0	TEST		4000FC0C
EC Register Bank	0	TEST		4000FC10
EC Register Bank	0	AHB Error Control Register		4000FC14
EC Register Bank	0	Interrupt Control Register		4000FC18
EC Register Bank	0	ETM TRACE Enable Register		4000FC1C
EC Register Bank	0	Debug Enable Register		4000FC20
EC Register Bank	0	TEST		4000FC24
EC Register Bank	0	WDT Event Count Register		4000FC28
EC Register Bank	0	AES HASH Byte Swap Control Register		4000FC2C
EC Register Bank	0	PECI DISABLE Register		4000FC40
EC Register Bank	0	TEST		4000FC44

MEC1725

TABLE 3-5: REGISTER MAP

Block	Instance	Register	Host Type	Register Address
EC Register Bank	0	TEST		4000FC48
EC Register Bank	0	TEST		4000FC4C
EC Register Bank	0	TEST		4000FC54
EC Register Bank	0	TEST		4000FC5C
EC Register Bank	0	TEST		4000FC60
EC Register Bank	0	GPIO Bank Power Register		4000FC64
EC Register Bank	0	TEST		4000FC68
EC Register Bank	0	TEST		4000FC6C
EC Register Bank	0	JTAG Master Configuration Register		4000FC70
EC Register Bank	0	JTAG Master Status Register		4000FC74
EC Register Bank	0	JTAG Master TDO Register		4000FC78
EC Register Bank	0	JTAG Master TDI Register		4000FC7C
EC Register Bank	0	JTAG Master TMS Register		4000FC80
EC Register Bank	0	JTAG Master Command Register		4000FC84
EC Register Bank	0	Vwire FW Override Register		4000FC90
EC Register Bank	0	TEST		4000FCF0
EC Register Bank	0	TEST		4000FD00
EC Register Bank	0	JTAG Master Configuration Register		4000FD70
EC Register Bank	0	JTAG Master Status Register		4000FD74
EC Register Bank	0	JTAG Master TDO Register		4000FD78
EC Register Bank	0	JTAG Master TDI Register		4000FD7C
EC Register Bank	0	JTAG Master TMS Register		4000FD80
EC Register Bank	0	JTAG Master Command Register		4000FD84
EC Register Bank	0	TEST		4000FD88
EC Register Bank	0	Virtual Wire Source Configuration Register		4000FD90
Power Clocks and Resets	0	System Sleep Control Register		40080100
Power Clocks and Resets	0	Processor Clock Control Register		40080104
Power Clocks and Resets	0	Slow Clock Control Register		40080108
Power Clocks and Resets	0	Oscillator ID Register		4008010C
Power Clocks and Resets	0	PCR Power Reset Status Register		40080110
Power Clocks and Resets	0	Power Reset Control Register		40080114
Power Clocks and Resets	0	System Reset Register		40080118
Power Clocks and Resets	0	TEST		4008011C
Power Clocks and Resets	0	TEST		40080120
Power Clocks and Resets	0	Sleep Enable 0 Register		40080130
Power Clocks and Resets	0	Sleep Enable 1 Register		40080134
Power Clocks and Resets	0	Sleep Enable 2 Register		40080138
Power Clocks and Resets	0	Sleep Enable 3 Register		4008013C
Power Clocks and Resets	0	Sleep Enable 4 Register		40080140
Power Clocks and Resets	0	Clock Required 0 Register		40080150
Power Clocks and Resets	0	Clock Required 1 Register		40080154
Power Clocks and Resets	0	Clock Required 2 Register		40080158
Power Clocks and Resets	0	Clock Required 3 Register		4008015C
Power Clocks and Resets	0	Clock Required 4 Register		40080160

TABLE 3-5: REGISTER MAP

Block	Instance	Register	Host Type	Register Address
Power Clocks and Resets	0	Reset Enable 0 Register		40080170
Power Clocks and Resets	0	Reset Enable 1 Register		40080174
Power Clocks and Resets	0	Reset Enable 2 Register		40080178
Power Clocks and Resets	0	Reset Enable 3 Register		4008017C
Power Clocks and Resets	0	Reset Enable 4 Register		40080180
Power Clocks and Resets	0	Peripheral Reset Lock Register		40080184
Power Clocks and Resets	0	VBAT Soft Reset Register		40080188
Power Clocks and Resets	0	Source 32KHz Clock VTR Register		4008018C
Power Clocks and Resets	0	TEST		40080190
Power Clocks and Resets	0	Counter 32KHz Period Register		400801C0
Power Clocks and Resets	0	Counter 32KHz Pulse High Register		400801C4
Power Clocks and Resets	0	Counter 32KHz Period Minimum Register		400801C8
Power Clocks and Resets	0	Counter 32KHz Period Maximum Register		400801CC
Power Clocks and Resets	0	Counter 32KHz Duty Variation Register		400801D0
Power Clocks and Resets	0	Counter 32KHz Duty Variation Maximum Register		400801D4
Power Clocks and Resets	0	Counter 32KHz Valid Register		400801D8
Power Clocks and Resets	0	Counter 32KHz Valid Minimum Register		400801DC
Power Clocks and Resets	0	Counter 32KHz Control Register		400801E0
Power Clocks and Resets	0	Source 32KHz Interrupt Status Register		400801E4
Power Clocks and Resets	0	Source 32KHz Interrupt Enable Register		400801E8
GPIO	0	GPIO000 Pin Control Register		40081000
GPIO	0	GPIO001 Pin Control Register		40081004
GPIO	0	GPIO002 Pin Control Register		40081008
GPIO	0	GPIO003 Pin Control Register		4008100C
GPIO	0	GPIO004 Pin Control Register		40081010
GPIO	0	GPIO005 Pin Control Register		40081014
GPIO	0	GPIO006 Pin Control Register		40081018
GPIO	0	GPIO007 Pin Control Register		4008101C
GPIO	0	GPIO010 Pin Control Register		40081020
GPIO	0	GPIO011 Pin Control Register		40081024
GPIO	0	GPIO012 Pin Control Register		40081028
GPIO	0	GPIO013 Pin Control Register		4008102C
GPIO	0	GPIO014 Pin Control Register		40081030
GPIO	0	GPIO015 Pin Control Register		40081034
GPIO	0	GPIO016 Pin Control Register		40081038
GPIO	0	GPIO017 Pin Control Register		4008103C
GPIO	0	GPIO020 Pin Control Register		40081040
GPIO	0	GPIO021 Pin Control Register		40081044
GPIO	0	GPIO022 Pin Control Register		40081048
GPIO	0	GPIO023 Pin Control Register		4008104C
GPIO	0	GPIO024 Pin Control Register		40081050
GPIO	0	GPIO025 Pin Control Register		40081054
GPIO	0	GPIO026 Pin Control Register		40081058
GPIO	0	GPIO027 Pin Control Register		4008105C

MEC1725

TABLE 3-5: REGISTER MAP

Block	Instance	Register	Host Type	Register Address
GPIO	0	GPIO030 Pin Control Register		40081060
GPIO	0	GPIO031 Pin Control Register		40081064
GPIO	0	GPIO032 Pin Control Register		40081068
GPIO	0	GPIO033 Pin Control Register		4008106C
GPIO	0	GPIO034 Pin Control Register		40081070
GPIO	0	GPIO035 Pin Control Register		40081074
GPIO	0	GPIO036 Pin Control Register		40081078
GPIO	0	GPIO040 Pin Control Register		40081080
GPIO	0	GPIO041 Pin Control Register		40081084
GPIO	0	GPIO042 Pin Control Register		40081088
GPIO	0	GPIO043 Pin Control Register		4008108C
GPIO	0	GPIO044 Pin Control Register		40081090
GPIO	0	GPIO045 Pin Control Register		40081094
GPIO	0	GPIO046 Pin Control Register		40081098
GPIO	0	GPIO047 Pin Control Register		4008109C
GPIO	0	GPIO050 Pin Control Register		400810A0
GPIO	0	GPIO051 Pin Control Register		400810A4
GPIO	0	GPIO052 Pin Control Register		400810A8
GPIO	0	GPIO053 Pin Control Register		400810AC
GPIO	0	GPIO054 Pin Control Register		400810B0
GPIO	0	GPIO055 Pin Control Register		400810B4
GPIO	0	GPIO056 Pin Control Register		400810B8
GPIO	0	GPIO057 Pin Control Register		400810BC
GPIO	0	GPIO060 Pin Control Register		400810C0
GPIO	0	GPIO061 Pin Control Register		400810C4
GPIO	0	GPIO063 Pin Control Register		400810CC
GPIO	0	GPIO064 Pin Control Register		400810D0
GPIO	0	GPIO065 Pin Control Register		400810D4
GPIO	0	GPIO066 Pin Control Register		400810D8
GPIO	0	GPIO067 Pin Control Register		400810DC
GPIO	0	GPIO070 Pin Control Register		400810E0
GPIO	0	GPIO071 Pin Control Register		400810E4
GPIO	0	GPIO072 Pin Control Register		400810E8
GPIO	0	GPIO073 Pin Control Register		400810EC
GPIO	0	GPIO074 Pin Control Register		400810F0
GPIO	0	GPIO075 Pin Control Register		400810F4
GPIO	0	GPIO076 Pin Control Register		400810F8
GPIO	0	GPIO100 Pin Control Register		40081100
GPIO	0	GPIO101 Pin Control Register		40081104
GPIO	0	GPIO102 Pin Control Register		40081108
GPIO	0	GPIO103 Pin Control Register		4008110C
GPIO	0	GPIO104 Pin Control Register		40081110
GPIO	0	GPIO105 Pin Control Register		40081114
GPIO	0	GPIO106 Pin Control Register		40081118

TABLE 3-5: REGISTER MAP

Block	Instance	Register	Host Type	Register Address
GPIO	0	GPIO107 Pin Control Register		4008111C
GPIO	0	GPIO110 Pin Control Register		40081120
GPIO	0	GPIO111 Pin Control Register		40081124
GPIO	0	GPIO112 Pin Control Register		40081128
GPIO	0	GPIO113 Pin Control Register		4008112C
GPIO	0	GPIO114 Pin Control Register		40081130
GPIO	0	GPIO115 Pin Control Register		40081134
GPIO	0	GPIO117 Pin Control Register		4008113C
GPIO	0	GPIO120 Pin Control Register		40081140
GPIO	0	GPIO121 Pin Control Register		40081144
GPIO	0	GPIO122 Pin Control Register		40081148
GPIO	0	GPIO123 Pin Control Register		4008114C
GPIO	0	GPIO124 Pin Control Register		40081150
GPIO	0	GPIO125 Pin Control Register		40081154
GPIO	0	GPIO126 Pin Control Register		40081158
GPIO	0	GPIO127 Pin Control Register		4008115C
GPIO	0	GPIO130 Pin Control Register		40081160
GPIO	0	GPIO131 Pin Control Register		40081164
GPIO	0	GPIO132 Pin Control Register		40081168
GPIO	0	GPIO140 Pin Control Register		40081180
GPIO	0	GPIO141 Pin Control Register		40081184
GPIO	0	GPIO142 Pin Control Register		40081188
GPIO	0	GPIO143 Pin Control Register		4008118C
GPIO	0	GPIO144 Pin Control Register		40081190
GPIO	0	GPIO145 Pin Control Register		40081194
GPIO	0	GPIO146 Pin Control Register		40081198
GPIO	0	GPIO147 Pin Control Register		4008119C
GPIO	0	GPIO150 Pin Control Register		400811A0
GPIO	0	GPIO151 Pin Control Register		400811A4
GPIO	0	GPIO152 Pin Control Register		400811A8
GPIO	0	GPIO153 Pin Control Register		400811AC
GPIO	0	GPIO154 Pin Control Register		400811B0
GPIO	0	GPIO155 Pin Control Register		400811B4
GPIO	0	GPIO156 Pin Control Register		400811B8
GPIO	0	GPIO157 Pin Control Register		400811BC
GPIO	0	GPIO160 Pin Control Register		400811C0
GPIO	0	GPIO161 Pin Control Register		400811C4
GPIO	0	GPIO162 Pin Control Register		400811C8
GPIO	0	GPIO165 Pin Control Register		400811D4
GPIO	0	GPIO166 Pin Control Register		400811D8
GPIO	0	GPIO170 Pin Control Register		400811E0
GPIO	0	GPIO171 Pin Control Register		400811E4
GPIO	0	GPIO172 Pin Control Register		400811E8
GPIO	0	GPIO175 Pin Control Register		400811F4

MEC1725

TABLE 3-5: REGISTER MAP

Block	Instance	Register	Host Type	Register Address
GPIO	0	GPIO200 Pin Control Register		40081200
GPIO	0	GPIO201 Pin Control Register		40081204
GPIO	0	GPIO202 Pin Control Register		40081208
GPIO	0	GPIO203 Pin Control Register		4008120C
GPIO	0	GPIO204 Pin Control Register		40081210
GPIO	0	GPIO205 Pin Control Register		40081214
GPIO	0	GPIO206 Pin Control Register		40081218
GPIO	0	GPIO207 Pin Control Register		4008121C
GPIO	0	GPIO210 Pin Control Register		40081220
GPIO	0	GPIO211 Pin Control Register		40081224
GPIO	0	GPIO212 Pin Control Register		40081228
GPIO	0	GPIO213 Pin Control Register		4008122C
GPIO	0	GPIO214 Pin Control Register		40081230
GPIO	0	GPIO215 Pin Control Register		40081234
GPIO	0	GPIO216 Pin Control Register		40081238
GPIO	0	GPIO217 Pin Control Register		4008123C
GPIO	0	GPIO221 Pin Control Register		40081244
GPIO	0	GPIO222 Pin Control Register		40081248
GPIO	0	GPIO223 Pin Control Register		4008124C
GPIO	0	GPIO224 Pin Control Register		40081250
GPIO	0	GPIO225 Pin Control Register		40081254
GPIO	0	GPIO226 Pin Control Register		40081258
GPIO	0	GPIO227 Pin Control Register		4008125C
GPIO	0	GPIO230 Pin Control Register		40081260
GPIO	0	GPIO231 Pin Control Register		40081264
GPIO	0	GPIO233 Pin Control Register		4008126C
GPIO	0	Input GPIO[000:036]		40081300
GPIO	0	Input GPIO[040:076]		40081304
GPIO	0	Input GPIO[100:127]		40081308
GPIO	0	Input GPIO[140:176]		4008130C
GPIO	0	Input GPIO[200:236]		40081310
GPIO	0	Input GPIO[240:276]		40081314
GPIO	0	Output GPIO[000:036]		40081380
GPIO	0	Output GPIO[040:076]		40081384
GPIO	0	Output GPIO[100:127]		40081388
GPIO	0	Output GPIO[140:176]		4008138C
GPIO	0	Output GPIO[200:236]		40081390
GPIO	0	Output GPIO[240:276]		40081394
GPIO	0	GPIO000 Pin Control2 Register		40081500
GPIO	0	GPIO001 Pin Control2 Register		40081504
GPIO	0	GPIO002 Pin Control2 Register		40081508
GPIO	0	GPIO003 Pin Control2 Register		4008150C
GPIO	0	GPIO004 Pin Control2 Register		40081510
GPIO	0	GPIO005 Pin Control2 Register		40081514

TABLE 3-5: REGISTER MAP

Block	Instance	Register	Host Type	Register Address
GPIO	0	GPIO006 Pin Control2 Register		40081518
GPIO	0	GPIO007 Pin Control2 Register		4008151C
GPIO	0	GPIO010 Pin Control2 Register		40081520
GPIO	0	GPIO011 Pin Control2 Register		40081524
GPIO	0	GPIO012 Pin Control2 Register		40081528
GPIO	0	GPIO013 Pin Control2 Register		4008152C
GPIO	0	GPIO014 Pin Control2 Register		40081530
GPIO	0	GPIO015 Pin Control2 Register		40081534
GPIO	0	GPIO016 Pin Control2 Register		40081538
GPIO	0	GPIO017 Pin Control2 Register		4008153C
GPIO	0	GPIO020 Pin Control2 Register		40081540
GPIO	0	GPIO021 Pin Control2 Register		40081544
GPIO	0	GPIO022 Pin Control2 Register		40081548
GPIO	0	GPIO023 Pin Control2 Register		4008154C
GPIO	0	GPIO024 Pin Control2 Register		40081550
GPIO	0	GPIO025 Pin Control2 Register		40081554
GPIO	0	GPIO026 Pin Control2 Register		40081558
GPIO	0	GPIO027 Pin Control2 Register		4008155C
GPIO	0	GPIO030 Pin Control2 Register		40081560
GPIO	0	GPIO031 Pin Control2 Register		40081564
GPIO	0	GPIO032 Pin Control2 Register		40081568
GPIO	0	GPIO033 Pin Control2 Register		4008156C
GPIO	0	GPIO034 Pin Control2 Register		40081570
GPIO	0	GPIO035 Pin Control2 Register		40081574
GPIO	0	GPIO036 Pin Control2 Register		40081578
GPIO	0	GPIO040 Pin Control2 Register		40081580
GPIO	0	GPIO041 Pin Control2 Register		40081584
GPIO	0	GPIO042 Pin Control2 Register		40081588
GPIO	0	GPIO043 Pin Control2 Register		4008158C
GPIO	0	GPIO044 Pin Control2 Register		40081590
GPIO	0	GPIO045 Pin Control2 Register		40081594
GPIO	0	GPIO046 Pin Control2 Register		40081598
GPIO	0	GPIO047 Pin Control2 Register		4008159C
GPIO	0	GPIO050 Pin Control2 Register		400815A0
GPIO	0	GPIO051 Pin Control2 Register		400815A4
GPIO	0	GPIO052 Pin Control2 Register		400815A8
GPIO	0	GPIO053 Pin Control2 Register		400815AC
GPIO	0	GPIO054 Pin Control2 Register		400815B0
GPIO	0	GPIO055 Pin Control2 Register		400815B4
GPIO	0	GPIO056 Pin Control2 Register		400815B8
GPIO	0	GPIO057 Pin Control2 Register		400815BC
GPIO	0	GPIO060 Pin Control2 Register		400815C0
GPIO	0	GPIO061 Pin Control2 Register		400815C4
GPIO	0	GPIO063 Pin Control2 Register		400815CC

MEC1725

TABLE 3-5: REGISTER MAP

Block	Instance	Register	Host Type	Register Address
GPIO	0	GPIO064 Pin Control2 Register		400815D0
GPIO	0	GPIO065 Pin Control2 Register		400815D4
GPIO	0	GPIO066 Pin Control2 Register		400815D8
GPIO	0	GPIO067 Pin Control2 Register		400815DC
GPIO	0	GPIO070 Pin Control2 Register		400815E0
GPIO	0	GPIO071 Pin Control2 Register		400815E4
GPIO	0	GPIO072 Pin Control2 Register		400815E8
GPIO	0	GPIO073 Pin Control2 Register		400815EC
GPIO	0	GPIO074 Pin Control2 Register		400815F0
GPIO	0	GPIO075 Pin Control2 Register		400815F4
GPIO	0	GPIO076 Pin Control2 Register		400815F8
GPIO	0	GPIO100 Pin Control2 Register		40081600
GPIO	0	GPIO101 Pin Control2 Register		40081604
GPIO	0	GPIO102 Pin Control2 Register		40081608
GPIO	0	GPIO103 Pin Control2 Register		4008160C
GPIO	0	GPIO104 Pin Control2 Register		40081610
GPIO	0	GPIO105 Pin Control2 Register		40081614
GPIO	0	GPIO106 Pin Control2 Register		40081618
GPIO	0	GPIO107 Pin Control2 Register		4008161C
GPIO	0	GPIO110 Pin Control2 Register		40081620
GPIO	0	GPIO111 Pin Control2 Register		40081624
GPIO	0	GPIO112 Pin Control2 Register		40081628
GPIO	0	GPIO113 Pin Control2 Register		4008162C
GPIO	0	GPIO114 Pin Control2 Register		40081630
GPIO	0	GPIO115 Pin Control2 Register		40081634
GPIO	0	GPIO116 Pin Control2 Register		40081638
GPIO	0	GPIO117 Pin Control2 Register		4008163C
GPIO	0	GPIO120 Pin Control2 Register		40081640
GPIO	0	GPIO121 Pin Control2 Register		40081644
GPIO	0	GPIO122 Pin Control2 Register		40081648
GPIO	0	GPIO123 Pin Control2 Register		4008164C
GPIO	0	GPIO124 Pin Control2 Register		40081650
GPIO	0	GPIO125 Pin Control2 Register		40081654
GPIO	0	GPIO126 Pin Control2 Register		40081658
GPIO	0	GPIO127 Pin Control2 Register		4008165C
GPIO	0	GPIO130 Pin Control2 Register		40081660
GPIO	0	GPIO131 Pin Control2 Register		40081664
GPIO	0	GPIO132 Pin Control2 Register		40081668
GPIO	0	GPIO133 Pin Control2 Register		4008166C
GPIO	0	GPIO134 Pin Control2 Register		40081670
GPIO	0	GPIO135 Pin Control2 Register		40081674
GPIO	0	GPIO140 Pin Control2 Register		40081680
GPIO	0	GPIO141 Pin Control2 Register		40081684
GPIO	0	GPIO142 Pin Control2 Register		40081688

TABLE 3-5: REGISTER MAP

Block	Instance	Register	Host Type	Register Address
GPIO	0	GPIO143 Pin Control2 Register		4008168C
GPIO	0	GPIO144 Pin Control2 Register		40081690
GPIO	0	GPIO145 Pin Control2 Register		40081694
GPIO	0	GPIO146 Pin Control2 Register		40081698
GPIO	0	GPIO147 Pin Control2 Register		4008169C
GPIO	0	GPIO150 Pin Control2 Register		400816A0
GPIO	0	GPIO151 Pin Control2 Register		400816A4
GPIO	0	GPIO152 Pin Control2 Register		400816A8
GPIO	0	GPIO153 Pin Control2 Register		400816AC
GPIO	0	GPIO154 Pin Control2 Register		400816B0
GPIO	0	GPIO155 Pin Control2 Register		400816B4
GPIO	0	GPIO156 Pin Control2 Register		400816B8
GPIO	0	GPIO157 Pin Control2 Register		400816BC
GPIO	0	GPIO160 Pin Control2 Register		400816C0
GPIO	0	GPIO161 Pin Control2 Register		400816C4
GPIO	0	GPIO162 Pin Control2 Register		400816C8
GPIO	0	GPIO165 Pin Control2 Register		400816D4
GPIO	0	GPIO166 Pin Control2 Register		400816D8
GPIO	0	GPIO170 Pin Control2 Register		400816E0
GPIO	0	GPIO171 Pin Control2 Register		400816E4
GPIO	0	GPIO172 Pin Control2 Register		400816E8
GPIO	0	GPIO175 Pin Control2 Register		400816F4
GPIO	0	GPIO200 Pin Control2 Register		40081700
GPIO	0	GPIO201 Pin Control2 Register		40081704
GPIO	0	GPIO202 Pin Control2 Register		40081708
GPIO	0	GPIO203 Pin Control2 Register		4008170C
GPIO	0	GPIO204 Pin Control2 Register		40081710
GPIO	0	GPIO205 Pin Control2 Register		40081714
GPIO	0	GPIO206 Pin Control2 Register		40081718
GPIO	0	GPIO207 Pin Control2 Register		4008171C
GPIO	0	GPIO210 Pin Control2 Register		40081720
GPIO	0	GPIO211 Pin Control2 Register		40081724
GPIO	0	GPIO212 Pin Control2 Register		40081728
GPIO	0	GPIO213 Pin Control2 Register		4008172C
GPIO	0	GPIO214 Pin Control2 Register		40081730
GPIO	0	GPIO215 Pin Control2 Register		40081734
GPIO	0	GPIO216 Pin Control2 Register		40081738
GPIO	0	GPIO217 Pin Control2 Register		4008173C
GPIO	0	GPIO221 Pin Control2 Register		40081744
GPIO	0	GPIO222 Pin Control2 Register		40081748
GPIO	0	GPIO223 Pin Control2 Register		4008174C
GPIO	0	GPIO224 Pin Control2 Register		40081750
GPIO	0	GPIO225 Pin Control2 Register		40081754
GPIO	0	GPIO226 Pin Control2 Register		40081758

MEC1725

TABLE 3-5: REGISTER MAP

Block	Instance	Register	Host Type	Register Address
GPIO	0	GPIO227 Pin Control2 Register		4008175C
GPIO	0	GPIO230 Pin Control2 Register		40081760
GPIO	0	GPIO231 Pin Control2 Register		40081764
GPIO	0	GPIO233 Pin Control2 Register		4008176C
OTP	0	Write Lock Register		40082044
OTP	0	Read Lock Register		40082048
OTP	0	Write Byte Lock Register		4008204C
OTP	0	Read Byte Lock Register		40082050
Mailbox	0	MBX_INDEX Register		400F0000
Mailbox	0	MBX_DATA Register		400F0001
Mailbox	0	HOST-to-EC Mailbox Register		400F0100
Mailbox	0	EC-to-Host Mailbox Register		400F0104
Mailbox	0	SMI Interrupt Source Register		400F0108
Mailbox	0	SMI Interrupt Mask Register		400F010C
Mailbox	0	Mailbox register [3:0]		400F0110
Mailbox	0	Mailbox register [7:4]		400F0114
Mailbox	0	Mailbox register [B:8]		400F0118
Mailbox	0	Mailbox register [F:C]		400F011C
Mailbox	0	Mailbox register [13:10]		400F0120
Mailbox	0	Mailbox register [17:14]		400F0124
Mailbox	0	Mailbox register [1B:18]		400F0128
Mailbox	0	Mailbox register [1F:1C]		400F012C
8042	0	EC_HOST Data / AUX Data Register	Run-time	400F0400
8042	0	Keyboard Status Read Register	Run-time	400F0404
8042	0	HOST2EC Data Register		400F0500
8042	0	EC Data Register		400F0500
8042	0	EC Keyboard Status Register		400F0504
8042	0	Keyboard Control Register		400F0508
8042	0	EC AUX Data Register		400F050C
8042	0	PCOBF Register		400F0514
8042	0	Activate Register	Config	400F0730
ACPI EC Channel	0	ACPI OS Data Register Byte 0 Register	Run-time	400F0800
ACPI EC Channel	0	ACPI OS Data Register Byte 1 Register	Run-time	400F0801
ACPI EC Channel	0	ACPI OS Data Register Byte 2 Register	Run-time	400F0802
ACPI EC Channel	0	ACPI OS Data Register Byte 3 Register	Run-time	400F0803
ACPI EC Channel	0	ACPI OS COMMAND Register	Run-time	400F0804
ACPI EC Channel	0	OS STATUS OS Register	Run-time	400F0804

TABLE 3-5: REGISTER MAP

Block	Instance	Register	Host Type	Register Address
ACPI EC Channel	0	OS Byte Control Register	Run-time	400F0805
ACPI EC Channel	0	Reserved	Run-time	400F0806
ACPI EC Channel	0	Reserved	Run-time	400F0807
ACPI EC Channel	0	EC2OS Data EC Byte 0 Register		400F0900
ACPI EC Channel	0	EC2OS Data EC Byte 1 Register		400F0901
ACPI EC Channel	0	EC2OS Data EC Byte 2 Register		400F0902
ACPI EC Channel	0	EC2OS Data EC Byte 3 Register		400F0903
ACPI EC Channel	0	EC STATUS Register		400F0904
ACPI EC Channel	0	EC Byte Control Register		400F0905
ACPI EC Channel	0	Reserved		400F0906
ACPI EC Channel	0	Reserved		400F0907
ACPI EC Channel	0	OS2EC Data EC Byte 0 Register		400F0908
ACPI EC Channel	0	OS2EC Data EC Byte 1 Register		400F0909
ACPI EC Channel	0	OS2EC Data EC Byte 2 Register		400F090A
ACPI EC Channel	0	OS2EC Data EC Byte 3 Register		400F090B
ACPI EC Channel	1	ACPI OS Data Register Byte 0 Register	Run-time	400F0C00
ACPI EC Channel	1	ACPI OS Data Register Byte 1 Register	Run-time	400F0C01
ACPI EC Channel	1	ACPI OS Data Register Byte 2 Register	Run-time	400F0C02
ACPI EC Channel	1	ACPI OS Data Register Byte 3 Register	Run-time	400F0C03
ACPI EC Channel	1	ACPI OS COMMAND Register	Run-time	400F0C04
ACPI EC Channel	1	OS STATUS OS Register	Run-time	400F0C04
ACPI EC Channel	1	OS Byte Control Register	Run-time	400F0C05
ACPI EC Channel	1	Reserved	Run-time	400F0C06
ACPI EC Channel	1	Reserved	Run-time	400F0C07
ACPI EC Channel	1	EC2OS Data EC Byte 0 Register		400F0D00
ACPI EC Channel	1	EC2OS Data EC Byte 1 Register		400F0D01
ACPI EC Channel	1	EC2OS Data EC Byte 2 Register		400F0D02
ACPI EC Channel	1	EC2OS Data EC Byte 3 Register		400F0D03
ACPI EC Channel	1	EC STATUS Register		400F0D04
ACPI EC Channel	1	EC Byte Control Register		400F0D05
ACPI EC Channel	1	Reserved		400F0D06
ACPI EC Channel	1	Reserved		400F0D07
ACPI EC Channel	1	OS2EC Data EC Byte 0 Register		400F0D08
ACPI EC Channel	1	OS2EC Data EC Byte 1 Register		400F0D09

MEC1725

TABLE 3-5: REGISTER MAP

Block	Instance	Register	Host Type	Register Address
ACPI EC Channel	1	OS2EC Data EC Byte 2 Register		400F0D0A
ACPI EC Channel	1	OS2EC Data EC Byte 3 Register		400F0D0B
ACPI EC Channel	2	ACPI OS Data Register Byte 0 Register	Run-time	400F1000
ACPI EC Channel	2	ACPI OS Data Register Byte 1 Register	Run-time	400F1001
ACPI EC Channel	2	ACPI OS Data Register Byte 2 Register	Run-time	400F1002
ACPI EC Channel	2	ACPI OS Data Register Byte 3 Register	Run-time	400F1003
ACPI EC Channel	2	ACPI OS COMMAND Register	Run-time	400F1004
ACPI EC Channel	2	OS STATUS OS Register	Run-time	400F1004
ACPI EC Channel	2	OS Byte Control Register	Run-time	400F1005
ACPI EC Channel	2	Reserved	Run-time	400F1006
ACPI EC Channel	2	Reserved	Run-time	400F1007
ACPI EC Channel	2	EC2OS Data EC Byte 0 Register		400F1100
ACPI EC Channel	2	EC2OS Data EC Byte 1 Register		400F1101
ACPI EC Channel	2	EC2OS Data EC Byte 2 Register		400F1102
ACPI EC Channel	2	EC2OS Data EC Byte 3 Register		400F1103
ACPI EC Channel	2	EC STATUS Register		400F1104
ACPI EC Channel	2	EC Byte Control Register		400F1105
ACPI EC Channel	2	Reserved		400F1106
ACPI EC Channel	2	Reserved		400F1107
ACPI EC Channel	2	OS2EC Data EC Byte 0 Register		400F1108
ACPI EC Channel	2	OS2EC Data EC Byte 1 Register		400F1109
ACPI EC Channel	2	OS2EC Data EC Byte 2 Register		400F110A
ACPI EC Channel	2	OS2EC Data EC Byte 3 Register		400F110B
ACPI EC Channel	3	ACPI OS Data Register Byte 0 Register	Run-time	400F1400
ACPI EC Channel	3	ACPI OS Data Register Byte 1 Register	Run-time	400F1401
ACPI EC Channel	3	ACPI OS Data Register Byte 2 Register	Run-time	400F1402
ACPI EC Channel	3	ACPI OS Data Register Byte 3 Register	Run-time	400F1403
ACPI EC Channel	3	ACPI OS COMMAND Register	Run-time	400F1404
ACPI EC Channel	3	OS STATUS OS Register	Run-time	400F1404
ACPI EC Channel	3	OS Byte Control Register	Run-time	400F1405

TABLE 3-5: REGISTER MAP

Block	Instance	Register	Host Type	Register Address
ACPI EC Channel	3	Reserved	Run-time	400F1406
ACPI EC Channel	3	Reserved	Run-time	400F1407
ACPI EC Channel	3	EC2OS Data EC Byte 0 Register		400F1500
ACPI EC Channel	3	EC2OS Data EC Byte 1 Register		400F1501
ACPI EC Channel	3	EC2OS Data EC Byte 2 Register		400F1502
ACPI EC Channel	3	EC2OS Data EC Byte 3 Register		400F1503
ACPI EC Channel	3	EC STATUS Register		400F1504
ACPI EC Channel	3	EC Byte Control Register		400F1505
ACPI EC Channel	3	Reserved		400F1506
ACPI EC Channel	3	Reserved		400F1507
ACPI EC Channel	3	OS2EC Data EC Byte 0 Register		400F1508
ACPI EC Channel	3	OS2EC Data EC Byte 1 Register		400F1509
ACPI EC Channel	3	OS2EC Data EC Byte 2 Register		400F150A
ACPI EC Channel	3	OS2EC Data EC Byte 3 Register		400F150B
ACPI EC Channel	4	ACPI OS Data Register Byte 0 Register	Run-time	400F1800
ACPI EC Channel	4	ACPI OS Data Register Byte 1 Register	Run-time	400F1801
ACPI EC Channel	4	ACPI OS Data Register Byte 2 Register	Run-time	400F1802
ACPI EC Channel	4	ACPI OS Data Register Byte 3 Register	Run-time	400F1803
ACPI EC Channel	4	ACPI OS COMMAND Register	Run-time	400F1804
ACPI EC Channel	4	OS STATUS OS Register	Run-time	400F1804
ACPI EC Channel	4	OS Byte Control Register	Run-time	400F1805
ACPI EC Channel	4	Reserved	Run-time	400F1806
ACPI EC Channel	4	Reserved	Run-time	400F1807
ACPI EC Channel	4	EC2OS Data EC Byte 0 Register		400F1900
ACPI EC Channel	4	EC2OS Data EC Byte 1 Register		400F1901
ACPI EC Channel	4	EC2OS Data EC Byte 2 Register		400F1902
ACPI EC Channel	4	EC2OS Data EC Byte 3 Register		400F1903
ACPI EC Channel	4	EC STATUS Register		400F1904
ACPI EC Channel	4	EC Byte Control Register		400F1905
ACPI EC Channel	4	Reserved		400F1906
ACPI EC Channel	4	Reserved		400F1907
ACPI EC Channel	4	OS2EC Data EC Byte 0 Register		400F1908
ACPI EC Channel	4	OS2EC Data EC Byte 1 Register		400F1909
ACPI EC Channel	4	OS2EC Data EC Byte 2 Register		400F190A
ACPI EC Channel	4	OS2EC Data EC Byte 3 Register		400F190B

MEC1725

TABLE 3-5: REGISTER MAP

Block	Instance	Register	Host Type	Register Address
ACPI PM1	0	Power Management 1 Status 1 Register	Run-time	400F1C00
ACPI PM1	0	Power Management 1 Status 2 Register	Run-time	400F1C01
ACPI PM1	0	Power Management 1 Enable 1 Register	Run-time	400F1C02
ACPI PM1	0	Power Management 1 Enable 2 Register	Run-time	400F1C03
ACPI PM1	0	Power Management 1 Control 1 Register	Run-time	400F1C04
ACPI PM1	0	Power Management 1 Control 2 Register	Run-time	400F1C05
ACPI PM1	0	Power Management 2 Control 1 Register	Run-time	400F1C06
ACPI PM1	0	Power Management 2 Control 2 Register	Run-time	400F1C07
ACPI PM1	0	Power Management 1 Status 1 Register		400F1D00
ACPI PM1	0	Power Management 1 Status 2 Register		400F1D01
ACPI PM1	0	Power Management 1 Enable 1 Register		400F1D02
ACPI PM1	0	Power Management 1 Enable 2 Register		400F1D03
ACPI PM1	0	Power Management 1 Control 1 Register		400F1D04
ACPI PM1	0	Power Management 1 Control 2 Register		400F1D05
ACPI PM1	0	Power Management 2 Control 1 Register		400F1D06
ACPI PM1	0	Power Management 2 Control 2 Register		400F1D07
ACPI PM1	0	EC_PM_STS Register		400F1D10
Port92-Legacy	0	Port 92 Register	Run-time	400F2000
Port92-Legacy	0	GATEA20 Control Register		400F2100
Port92-Legacy	0	SETGA20L Register		400F2108
Port92-Legacy	0	RSTGA20L Register		400F210C
Port92-Legacy	0	Port 92 Enable	Config	400F2330
UART	0	Receive Buffer Register	Run-time	400F2400
UART	0	Transmit Buffer Register	Run-time	400F2400
UART	0	Programmable Baud Rate Generator LSB Register	Run-time	400F2400
UART	0	Programmable Baud Rate Generator MSB Register	Run-time	400F2401
UART	0	Interrupt Enable Register	Run-time	400F2401
UART	0	FIFO Control Register	Run-time	400F2402
UART	0	Interrupt Identification Register	Run-time	400F2402

TABLE 3-5: REGISTER MAP

Block	Instance	Register	Host Type	Register Address
UART	0	Line Control Register	Run-time	400F2403
UART	0	Modem Control Register	Run-time	400F2404
UART	0	Line Status Register	Run-time	400F2405
UART	0	Modem Status Register	Run-time	400F2406
UART	0	Scratchpad Register	Run-time	400F2407
UART	0	Activate Register	Config	400F2730
UART	0	Configuration Select Register	Config	400F27F0
UART	1	Receive Buffer Register	Run-time	400F2800
UART	1	Transmit Buffer Register	Run-time	400F2800
UART	1	Programmable Baud Rate Generator LSB Register	Run-time	400F2800
UART	1	Programmable Baud Rate Generator MSB Register	Run-time	400F2801
UART	1	Interrupt Enable Register	Run-time	400F2801
UART	1	FIFO Control Register	Run-time	400F2802
UART	1	Interrupt Identification Register	Run-time	400F2802
UART	1	Line Control Register	Run-time	400F2803
UART	1	Modem Control Register	Run-time	400F2804
UART	1	Line Status Register	Run-time	400F2805
UART	1	Modem Status Register	Run-time	400F2806
UART	1	Scratchpad Register	Run-time	400F2807
UART	1	Activate Register	Config	400F2B30
UART	1	Configuration Select Register	Config	400F2BF0
eSPI IO Component	0	Index Register		400F3400
eSPI IO Component	0	Data Register		400F3401
eSPI IO Component	0	Peripheral Channel Last Cycle Register		400F3500
eSPI IO Component	0	Peripheral Channel Error Address Register		400F350C
eSPI IO Component	0	Peripheral Channel Status Register		400F3514
eSPI IO Component	0	Peripheral Channel Interrupt Enable Register		400F3518

MEC1725

TABLE 3-5: REGISTER MAP

Block	Instance	Register	Host Type	Register Address
eSPI IO Component	0	Reserved		400F351C
eSPI IO Component	0	BAR Inhibit Register		400F3520
eSPI IO Component	0	eSPI BAR Init Register		400F3528
eSPI IO Component	0	EC IRQ Register		400F352C
eSPI IO Component	0	TEST		400F3530
eSPI IO Component	0	eSPI IO Component BAR		400F3534
eSPI IO Component	0	eSPI Memory Component BAR		400F3538
eSPI IO Component	0	Mailbox BAR		400F353C
eSPI IO Component	0	8042 Emulated Keyboard Controller BAR		400F3540
eSPI IO Component	0	ACIP EC Channel 0 BAR		400F3544
eSPI IO Component	0	ACIP EC Channel 1 BAR		400F3548
eSPI IO Component	0	ACIP EC Channel 2 BAR		400F354C
eSPI IO Component	0	ACIP EC Channel 3 BAR		400F3550
eSPI IO Component	0	ACIP EC Channel 4 BAR		400F3554
eSPI IO Component	0	ACPI PM1 BAR		400F3558
eSPI IO Component	0	Legacy (Fast Keyboard) BAR		400F355C
eSPI IO Component	0	UART 0 BAR		400F3560
eSPI IO Component	0	UART 1 BAR		400F3564
eSPI IO Component	0	Embedded Memory Interface (EMI) 0 BAR		400F3568
eSPI IO Component	0	Embedded Memory Interface (EMI) 1 BAR		400F356C
eSPI IO Component	0	Embedded Memory Interface (EMI) 2 BAR		400F3570
eSPI IO Component	0	BIOS Debug Port (Port 80) 0 BAR		400F3574
eSPI IO Component	0	BIOS Debug Port (Port 80) 1 BAR		400F3578
eSPI IO Component	0	RTC BAR		400F357C
eSPI IO Component	0	TEST		400F3584
eSPI IO Component	0	TEST		400F358C
eSPI IO Component	0	LTR Peripheral Status Register		400F3620
eSPI IO Component	0	LTR Peripheral Enable Register		400F3624
eSPI IO Component	0	LTR Peripheral Control Register		400F3628
eSPI IO Component	0	LTR Peripheral Message Register		400F362C
eSPI IO Component	0	OOB Channel Receive Address Register		400F3640
eSPI IO Component	0	OOB Channel Transmit Address Register		400F3648
eSPI IO Component	0	OOB Channel Receive Length Register		400F3650
eSPI IO Component	0	OOB Channel Transmit Length Register		400F3654
eSPI IO Component	0	OOB Channel Receive Control Register		400F3658
eSPI IO Component	0	OOB Channel Receive Interrupt Enable Register		400F365C
eSPI IO Component	0	OOB Channel Receive Status Register		400F3660
eSPI IO Component	0	OOB Channel Transmit Control Register		400F3664
eSPI IO Component	0	OOB Channel Transmit Interrupt Enable Register		400F3668
eSPI IO Component	0	OOB Channel Transmit Status Register		400F366C
eSPI IO Component	0	Flash Access Channel Flash Address Register		400F3680
eSPI IO Component	0	Flash Access Channel Buffer Address Register		400F3688
eSPI IO Component	0	Flash Access Channel Transfer Length Register		400F3690
eSPI IO Component	0	Flash Access Channel Control Register		400F3694

TABLE 3-5: REGISTER MAP

Block	Instance	Register	Host Type	Register Address
eSPI IO Component	0	Flash Access Channel Interrupt Enable Register		400F3698
eSPI IO Component	0	Flash Access Channel Configuration Register		400F369C
eSPI IO Component	0	Flash Access Channel Status Register		400F36A0
eSPI IO Component	0	Virtual Wire Status		400F36B0
eSPI IO Component	0	eSPI Capabilities ID Register		400F36E0
eSPI IO Component	0	eSPI Capabilities Global Capabilities 0 Register		400F36E1
eSPI IO Component	0	eSPI Capabilities Global Capabilities 1 Register		400F36E2
eSPI IO Component	0	eSPI Peripheral Channel Capabilities Register		400F36E3
eSPI IO Component	0	eSPI Virtual Wire Channel Capabilities Register		400F36E4
eSPI IO Component	0	eSPI OOB Channel Capabilities Register		400F36E5
eSPI IO Component	0	eSPI Flash Channel Capabilities Register		400F36E6
eSPI IO Component	0	eSPI Peripheral Channel Ready Register		400F36E7
eSPI IO Component	0	eSPI OOB Channel Ready Register		400F36E8
eSPI IO Component	0	eSPI Flash Channel Ready Register		400F36E9
eSPI IO Component	0	eSPI Reset Interrupt Status Register		400F36EA
eSPI IO Component	0	eSPI Reset Interrupt Enable Register		400F36EB
eSPI IO Component	0	PLTRST Source Register		400F36EC
eSPI IO Component	0	eSPI Virtual Channel Ready Register		400F36ED
eSPI IO Component	0	eSPI Activate Register	Config	400F3730
eSPI IO Component	0	eSPI IO Component BAR	Config	400F3734
eSPI IO Component	0	eSPI Memory Component BAR	Config	400F3738
eSPI IO Component	0	Mailbox BAR	Config	400F373C
eSPI IO Component	0	8042 Emulated Keyboard Controller BAR	Config	400F3740
eSPI IO Component	0	ACPI EC Channel 0 BAR	Config	400F3744
eSPI IO Component	0	ACPI EC Channel 1 BAR	Config	400F3748
eSPI IO Component	0	ACPI EC Channel 2 BAR	Config	400F374C
eSPI IO Component	0	ACPI EC Channel 3 BAR	Config	400F3750
eSPI IO Component	0	ACPI EC Channel 4 BAR	Config	400F3754
eSPI IO Component	0	ACPI PM1 BAR	Config	400F3758
eSPI IO Component	0	Legacy (Fast Keyboard) BAR	Config	400F375C
eSPI IO Component	0	UART 0 BAR	Config	400F3760
eSPI IO Component	0	UART 1 BAR	Config	400F3764

MEC1725

TABLE 3-5: REGISTER MAP

Block	Instance	Register	Host Type	Register Address
eSPI IO Component	0	Embedded Memory Interface (EMI) 0 BAR	Config	400F3768
eSPI IO Component	0	Embedded Memory Interface (EMI) 1 BAR	Config	400F376C
eSPI IO Component	0	Embedded Memory Interface (EMI) 2 BAR	Config	400F3770
eSPI IO Component	0	BIOS Debug Port (Port 80) 0 BAR	Config	400F3774
eSPI IO Component	0	BIOS Debug Port (Port 80) 1 BAR	Config	400F3778
eSPI IO Component	0	RTC BAR	Config	400F377C
eSPI IO Component	0	32 Byte Test Block BAR	Config	400F3784
eSPI IO Component	0	Glue BAR	Config	400F378C
eSPI IO Component	0	Mailbox SERIRQ 0	Config	400F37AC
eSPI IO Component	0	Mailbox SERIRQ 1	Config	400F37AD
eSPI IO Component	0	8042 SERIRQ 0	Config	400F37AE
eSPI IO Component	0	8042 SERIRQ 1	Config	400F37AF
eSPI IO Component	0	ACPI EC 0 SERIRQ	Config	400F37B0
eSPI IO Component	0	ACPI EC 1 SERIRQ	Config	400F37B1
eSPI IO Component	0	ACPI EC 2 SERIRQ	Config	400F37B2
eSPI IO Component	0	ACPI EC 3 SERIRQ	Config	400F37B3
eSPI IO Component	0	ACPI EC 4 SERIRQ	Config	400F37B4
eSPI IO Component	0	UART 0 SERIRQ	Config	400F37B5
eSPI IO Component	0	UART 1 SERIRQ	Config	400F37B6
eSPI IO Component	0	EMI 0 SERIRQ 0	Config	400F37B7
eSPI IO Component	0	EMI 0 SERIRQ 1	Config	400F37B8
eSPI IO Component	0	EMI 1 SERIRQ 0	Config	400F37B9
eSPI IO Component	0	EMI 1 SERIRQ 1	Config	400F37BA
eSPI IO Component	0	RTC SERIRQ	Config	400F37BD

TABLE 3-5: REGISTER MAP

Block	Instance	Register	Host Type	Register Address
eSPI IO Component	0	EC SERIRQ	Config	400F37BE
eSPI IO Component	0	eSPI Virtual Wire Error	Config	400F37F0
eSPI Memory Component	0	Mailbox BAR		400F3930
eSPI Memory Component	0	ACIP EC Channel 0 BAR		400F393A
eSPI Memory Component	0	ACIP EC Channel 1 BAR		400F3944
eSPI Memory Component	0	ACIP EC Channel 2 BAR		400F394E
eSPI Memory Component	0	ACIP EC Channel 3 BAR		400F3958
eSPI Memory Component	0	ACIP EC Channel 4 BAR		400F3962
eSPI Memory Component	0	Embedded Memory Interface (EMI) 0 BAR		400F396C
eSPI Memory Component	0	Embedded Memory Interface (EMI) 1 BAR		400F3976
eSPI Memory Component	0	Embedded Memory Interface (EMI) 2 BAR		400F3980
eSPI Memory Component	0	TEST		400F398A
eSPI Memory Component	0	SRAM BAR 0		400F39AC
eSPI Memory Component	0	SRAM BAR 1		400F39B6
eSPI Memory Component	0	Bus Master Status Register		400F3A00
eSPI Memory Component	0	Bus Master Interrupt Enable Register		400F3A04
eSPI Memory Component	0	Bus Master Configuration Register		400F3A08
eSPI Memory Component	0	Bus Master 1 Control Register		400F3A10
eSPI Memory Component	0	Bus Master 1 Host Address Register		400F3A14
eSPI Memory Component	0	Bus Master 1 Internal Address Register		400F3A1C
eSPI Memory Component	0	Bus Master 2 Control Register		400F3A24
eSPI Memory Component	0	Bus Master 2 Host Address Register		400F3A28
eSPI Memory Component	0	Bus Master 2 Internal Address Register		400F3A30
eSPI Memory Component	0	Mailbox BAR	Config	400F3B30
eSPI Memory Component	0	ACIP EC Channel 0 BAR	Config	400F3B3A
eSPI Memory Component	0	ACIP EC Channel 1 BAR	Config	400F3B44
eSPI Memory Component	0	ACIP EC Channel 2 BAR	Config	400F3B4E
eSPI Memory Component	0	ACIP EC Channel 3 BAR	Config	400F3B58
eSPI Memory Component	0	ACIP EC Channel 3 BAR	Config	400F3B62
eSPI Memory Component	0	Embedded Memory Interface (EMI) 0 BAR	Config	400F3B6C
eSPI Memory Component	0	Embedded Memory Interface (EMI) 1 BAR	Config	400F3B76
eSPI Memory Component	0	Embedded Memory Interface (EMI) 1 BAR	Config	400F3B80
eSPI Memory Component	0	TEST	Config	400F3B8A

MEC1725

TABLE 3-5: REGISTER MAP

Block	Instance	Register	Host Type	Register Address
eSPI Memory Component	0	SRAM BAR 0	Config	400F3BAC
eSPI Memory Component	0	SRAM BAR 1	Config	400F3BB6
Glue Logic	0	S0ix State detection enable Register	Run-time	400F3C04
Glue Logic	0	PWRGD State Source Configuration Register		400F3D0C
Glue Logic	0	S0ix State Detection Configuration Register		400F3D10
Glue Logic	0	Signal Monitor State Register		400F3D28
Glue Logic	0	Signal Monitor Interrupt pending Register		400F3D2C
Glue Logic	0	Signal Monitor Interrupt enable Register		400F3D30
eSPI SAF Bridge Component	0	Test		40008000
eSPI SAF Bridge Component	0	SAF EC Portal Command Register		40008018
eSPI SAF Bridge Component	0	SAF EC Portal Flash Address Register		4000801C
eSPI SAF Bridge Component	0	SAF EC Portal Start Register		40008020
eSPI SAF Bridge Component	0	SAF EC Portal Buffer Address Register		40008024
eSPI SAF Bridge Component	0	SAF EC Portal Status Register		40008028
eSPI SAF Bridge Component	0	SAF EC Portal Interrupt Enable Register		4000802C
eSPI SAF Bridge Component	0	SAF Flash Configuration Size Limit Register		40008030
eSPI SAF Bridge Component	0	SAF Flash Configuration Threshold Register		40008034
eSPI SAF Bridge Component	0	SAF Flash Configuration Misc Register		40008038
eSPI SAF Bridge Component	0	SAF eSPI Monitor Status Register		4000803C
eSPI SAF Bridge Component	0	SAF eSPI Monitor Interrupt Enable Register		40008040
eSPI SAF Bridge Component	0	SAF EC Busy Register		40008044
eSPI SAF Bridge Component	0	TEST		40008048
eSPI SAF Bridge Component	0	CS0 Opcode:SAF Flash Configuration Opcode Register A		4000804C
eSPI SAF Bridge Component	0	CS0 Opcode:SAF Flash Configuration Opcode Register B		40008050
eSPI SAF Bridge Component	0	CS0 opcode:SAF Flash Configuration Opcode Register C		40008054
eSPI SAF Bridge Component	0	CS0 Opcode;SAF Flash Configuration Per-Flash Descriptors Register		40008058

TABLE 3-5: REGISTER MAP

Block	Instance	Register	Host Type	Register Address
eSPI SAF Bridge Component	0	CS1 Opcode:SAF Flash Configuration Opcode Register A		4000805C
eSPI SAF Bridge Component	0	CS1 Opcode:SAF Flash Configuration Opcode Register B		40008060
eSPI SAF Bridge Component	0	CS1 opcode:SAF Flash Configuration Opcode Register C		40008064
eSPI SAF Bridge Component	0	CS1 Opcode;SAF Flash Configuration Per-Flash Descriptors Register		40008068
eSPI SAF Bridge Component	0	SAF Flash Configuration General Descriptors Register		4000806C
eSPI SAF Bridge Component	0	SAF Protection Lock Bit Register		40008070
eSPI SAF Bridge Component	0	SAF Protection Dirty Bit Register		40008074
eSPI SAF Bridge Component	0	SAF Tag Map Register 0		40008078
eSPI SAF Bridge Component	0	SAF Tag Map Register 1		4000807C
eSPI SAF Bridge Component	0	SAF Tag Map Register 2		40008080
eSPI SAF Bridge Component	0	SAF Protection Region [RR] Start Register		40008084
eSPI SAF Bridge Component	0	SAF Protection Region [RR] Limit Register		40008088
eSPI SAF Bridge Component	0	SAF Write Protection Bitmap [RR] Register		4000808C
eSPI SAF Bridge Component	0	SAF Read Protection Bitmap [RR] Register		40008090
eSPI SAF Bridge Component	0	SAF Protection Region [RR] Start Register		40008094
eSPI SAF Bridge Component	0	SAF Protection Region [RR] Limit Register		40008098
eSPI SAF Bridge Component	0	SAF Write Protection Bitmap [RR] Register		4000809C
eSPI SAF Bridge Component	0	SAF Read Protection Bitmap [RR] Register		400080A0
eSPI SAF Bridge Component	0	SAF Protection Region [RR] Start Register		400080A4
eSPI SAF Bridge Component	0	SAF Protection Region [RR] Limit Register		400080A8
eSPI SAF Bridge Component	0	SAF Write Protection Bitmap [RR] Register		400080AC
eSPI SAF Bridge Component	0	SAF Read Protection Bitmap [RR] Register		400080B0
eSPI SAF Bridge Component	0	SAF Protection Region [RR] Start Register		400080B4
eSPI SAF Bridge Component	0	SAF Protection Region [RR] Limit Register		400080B8

MEC1725

TABLE 3-5: REGISTER MAP

Block	Instance	Register	Host Type	Register Address
eSPI SAF Bridge Component	0	SAF Write Protection Bitmap [RR] Register		400080BC
eSPI SAF Bridge Component	0	SAF Read Protection Bitmap [RR] Register		400080C0
eSPI SAF Bridge Component	0	SAF Protection Region [RR] Start Register		400080C4
eSPI SAF Bridge Component	0	SAF Protection Region [RR] Limit Register		400080C8
eSPI SAF Bridge Component	0	SAF Write Protection Bitmap [RR] Register		400080CC
eSPI SAF Bridge Component	0	SAF Read Protection Bitmap [RR] Register		400080D0
eSPI SAF Bridge Component	0	SAF Protection Region [RR] Start Register		400080D4
eSPI SAF Bridge Component	0	SAF Protection Region [RR] Limit Register		400080D8
eSPI SAF Bridge Component	0	SAF Write Protection Bitmap [RR] Register		400080DC
eSPI SAF Bridge Component	0	SAF Read Protection Bitmap [RR] Register		400080E0
eSPI SAF Bridge Component	0	SAF Protection Region [RR] Start Register		400080E4
eSPI SAF Bridge Component	0	SAF Protection Region [RR] Limit Register		400080E8
eSPI SAF Bridge Component	0	SAF Write Protection Bitmap [RR] Register		400080EC
eSPI SAF Bridge Component	0	SAF Read Protection Bitmap [RR] Register		400080F0
eSPI SAF Bridge Component	0	SAF Protection Region [RR] Start Register		400080F4
eSPI SAF Bridge Component	0	SAF Protection Region [RR] Limit Register		400080F8
eSPI SAF Bridge Component	0	SAF Write Protection Bitmap [RR] Register		400080FC
eSPI SAF Bridge Component	0	SAF Read Protection Bitmap [RR] Register		40008100
eSPI SAF Bridge Component	0	SAF Protection Region [RR] Start Register		40008104
eSPI SAF Bridge Component	0	SAF Protection Region [RR] Limit Register		40008108
eSPI SAF Bridge Component	0	SAF Write Protection Bitmap [RR] Register		4000810C
eSPI SAF Bridge Component	0	SAF Read Protection Bitmap [RR] Register		40008110
eSPI SAF Bridge Component	0	SAF Protection Region [RR] Start Register		40008114
eSPI SAF Bridge Component	0	SAF Protection Region [RR] Limit Register		40008118

TABLE 3-5: REGISTER MAP

Block	Instance	Register	Host Type	Register Address
eSPI SAF Bridge Component	0	SAF Write Protection Bitmap [RR] Register		4000811C
eSPI SAF Bridge Component	0	SAF Read Protection Bitmap [RR] Register		40008120
eSPI SAF Bridge Component	0	SAF Protection Region [RR] Start Register		40008124
eSPI SAF Bridge Component	0	SAF Protection Region [RR] Limit Register		40008128
eSPI SAF Bridge Component	0	SAF Write Protection Bitmap [RR] Register		4000812C
eSPI SAF Bridge Component	0	SAF Read Protection Bitmap [RR] Register		40008130
eSPI SAF Bridge Component	0	SAF Protection Region [RR] Start Register		40008134
eSPI SAF Bridge Component	0	SAF Protection Region [RR] Limit Register		40008138
eSPI SAF Bridge Component	0	SAF Write Protection Bitmap [RR] Register		4000813C
eSPI SAF Bridge Component	0	SAF Read Protection Bitmap [RR] Register		40008140
eSPI SAF Bridge Component	0	SAF Protection Region [RR] Start Register		40008144
eSPI SAF Bridge Component	0	SAF Protection Region [RR] Limit Register		40008148
eSPI SAF Bridge Component	0	SAF Write Protection Bitmap [RR] Register		4000814C
eSPI SAF Bridge Component	0	SAF Read Protection Bitmap [RR] Register		40008150
eSPI SAF Bridge Component	0	SAF Protection Region [RR] Start Register		40008154
eSPI SAF Bridge Component	0	SAF Protection Region [RR] Limit Register		40008158
eSPI SAF Bridge Component	0	SAF Write Protection Bitmap [RR] Register		4000815C
eSPI SAF Bridge Component	0	SAF Read Protection Bitmap [RR] Register		40008160
eSPI SAF Bridge Component	0	SAF Protection Region [RR] Start Register		40008164
eSPI SAF Bridge Component	0	SAF Protection Region [RR] Limit Register		40008168
eSPI SAF Bridge Component	0	SAF Write Protection Bitmap [RR] Register		4000816C
eSPI SAF Bridge Component	0	SAF Read Protection Bitmap [RR] Register		40008170
eSPI SAF Bridge Component	0	SAF Protection Region [RR] Start Register		40008174
eSPI SAF Bridge Component	0	SAF Protection Region [RR] Limit Register		40008178

MEC1725

TABLE 3-5: REGISTER MAP

Block	Instance	Register	Host Type	Register Address
eSPI SAF Bridge Component	0	SAF Write Protection Bitmap [RR] Register		4000817C
eSPI SAF Bridge Component	0	SAF Read Protection Bitmap [RR] Register		40008180
eSPI SAF Bridge Component	0	SAF Protection Region [RR] Start Register		40008184
eSPI SAF Bridge Component	0	SAF Protection Region [RR] Limit Register		40008188
eSPI SAF Bridge Component	0	SAF Write Protection Bitmap [RR] Register		4000818C
eSPI SAF Bridge Component	0	SAF Read Protection Bitmap [RR] Register		40008190
eSPI SAF Bridge Component	0	SAF Poll Timeout Register		40008194
eSPI SAF Bridge Component	0	SAF Poll Interval Register		40008198
eSPI SAF Bridge Component	0	SAF Suspend/Resume Interval Register		4000819C
eSPI SAF Bridge Component	0	SAF Consecutive Read Timeout Register		400081A0
eSPI SAF Bridge Component	0	SAF Flash Configuration Poll2 Mask Register		400081A4
eSPI SAF Bridge Component	0	SAF Flash Configuration Special Mode Register		400081A8
eSPI SAF Bridge Component	0	SAF Suspend Check Delay Register		400081AC
eSPI SAF Bridge Component	0	SAF Flash Configuration Special Mode Register		400081B0
eSPI SAF Bridge Component	0	SAF DnX Protection Bypass		400081B4
eSPI SAF Bridge Component	0	SAF Activity Count Reload Value Register		400081B8
eSPI SAF Bridge Component	0	SAF Power Down Control Register		400081BC
eSPI SAF Bridge Component	0	SAF Memory Power Status Register		400081C0
eSPI SAF Bridge Component	0	SAF Config CS0 Opcode Register		400081C4
eSPI SAF Bridge Component	0	SAF Config CS1 Opcode Register		400081C8
eSPI SAF Bridge Component	0	SAF Flash Power Down /Up Timeout Register		400081CC
eSPI SAF Bridge Component	0	Clock Divider for CS0 Register		40008200
eSPI SAF Bridge Component	0	Clock Divider for CS1 Register		40008204
eSPI SAF Bridge Component	0	SAF RPMC OP2 eSPI Result Register		40008208

TABLE 3-5: REGISTER MAP

Block	Instance	Register	Host Type	Register Address
eSPI SAF Bridge Component	0	SAF RPMC OP2 EC0 Result Register		4000820C
eSPI SAF Bridge Component	0	SAF RPMC OP2 EC1 Result Register		40008210
eSPI SAF Communication Registers	0	SAF Communication Mode Register		400712B8
EMI	0	HOST-to-EC Mailbox Register	Run-time	400F4000
EMI	0	EC-to-HOST Mailbox Register	Run-time	400F4001
EMI	0	EC Address LSB Register	Run-time	400F4002
EMI	0	EC Address MSB Register	Run-time	400F4003
EMI	0	EC Data Byte 0 Register	Run-time	400F4004
EMI	0	EC Data Byte 1 Register	Run-time	400F4005
EMI	0	EC Data Byte 2 Register	Run-time	400F4006
EMI	0	EC Data Byte 3 Register	Run-time	400F4007
EMI	0	Interrupt Source LSB Register	Run-time	400F4008
EMI	0	Interrupt Source MSB Register	Run-time	400F4009
EMI	0	Interrupt Mask LSB Register	Run-time	400F400A
EMI	0	Interrupt Mask MSB Register	Run-time	400F400B
EMI	0	Application ID Register	Run-time	400F400C
EMI	0	Application ID Assignment Register	Run-time	400F4010
EMI	0	HOST-to-EC Mailbox Register		400F4100
EMI	0	EC-to-HOST Mailbox Register		400F4101
EMI	0	Memory Base Address 0 Register		400F4104
EMI	0	Memory Read Limit 0 Register		400F4108
EMI	0	Memory Write Limit 0 Register		400F410A
EMI	0	Memory Base Address 1 Register		400F410C
EMI	0	Memory Read Limit 1 Register		400F4110
EMI	0	Memory Write Limit 1 Register		400F4112
EMI	0	Interrupt Set Register		400F4114
EMI	0	Host Clear Enable Register		400F4116
EMI	0	Application ID Status 0 Register		400F4120
EMI	0	Application ID Status 1 Register		400F4124
EMI	0	Application ID Status 2 Register		400F4128

MEC1725

TABLE 3-5: REGISTER MAP

Block	Instance	Register	Host Type	Register Address
EMI	0	Application ID Status 3 Register		400F412C
EMI	0	Application ID Status 4 Register		400F4130
EMI	0	Application ID Status 5 Register		400F4134
EMI	0	Application ID Status 6 Register		400F4138
EMI	0	Application ID Status 7 Register		400F413C
EMI	1	HOST-to-EC Mailbox Register	Run-time	400F4400
EMI	1	EC-to-HOST Mailbox Register	Run-time	400F4401
EMI	1	EC Address LSB Register	Run-time	400F4402
EMI	1	EC Address MSB Register	Run-time	400F4403
EMI	1	EC Data Byte 0 Register	Run-time	400F4404
EMI	1	EC Data Byte 1 Register	Run-time	400F4405
EMI	1	EC Data Byte 2 Register	Run-time	400F4406
EMI	1	EC Data Byte 3 Register	Run-time	400F4407
EMI	1	Interrupt Source LSB Register	Run-time	400F4408
EMI	1	Interrupt Source MSB Register	Run-time	400F4409
EMI	1	Interrupt Mask LSB Register	Run-time	400F440A
EMI	1	Interrupt Mask MSB Register	Run-time	400F440B
EMI	1	Application ID Register	Run-time	400F440C
EMI	1	Application ID Assignment Register	Run-time	400F4410
EMI	1	HOST-to-EC Mailbox Register		400F4500
EMI	1	EC-to-HOST Mailbox Register		400F4501
EMI	1	Memory Base Address 0 Register		400F4504
EMI	1	Memory Read Limit 0 Register		400F4508
EMI	1	Memory Write Limit 0 Register		400F450A
EMI	1	Memory Base Address 1 Register		400F450C
EMI	1	Memory Read Limit 1 Register		400F4510
EMI	1	Memory Write Limit 1 Register		400F4512
EMI	1	Interrupt Set Register		400F4514
EMI	1	Host Clear Enable Register		400F4516
EMI	1	Application ID Status 0 Register		400F4520
EMI	1	Application ID Status 1 Register		400F4524
EMI	1	Application ID Status 2 Register		400F4528
EMI	1	Application ID Status 3 Register		400F452C

TABLE 3-5: REGISTER MAP

Block	Instance	Register	Host Type	Register Address
EMI	1	Application ID Status 4 Register		400F4530
EMI	1	Application ID Status 5 Register		400F4534
EMI	1	Application ID Status 6 Register		400F4538
EMI	1	Application ID Status 7 Register		400F453C
EMI	2	HOST-to-EC Mailbox Register	Run-time	400F4800
EMI	2	EC-to-HOST Mailbox Register	Run-time	400F4801
EMI	2	EC Address LSB Register	Run-time	400F4802
EMI	2	EC Address MSB Register	Run-time	400F4803
EMI	2	EC Data Byte 0 Register	Run-time	400F4804
EMI	2	EC Data Byte 1 Register	Run-time	400F4805
EMI	2	EC Data Byte 2 Register	Run-time	400F4806
EMI	2	EC Data Byte 3 Register	Run-time	400F4807
EMI	2	Interrupt Source LSB Register	Run-time	400F4808
EMI	2	Interrupt Source MSB Register	Run-time	400F4809
EMI	2	Interrupt Mask LSB Register	Run-time	400F480A
EMI	2	Interrupt Mask MSB Register	Run-time	400F480B
EMI	2	Application ID Register	Run-time	400F480C
EMI	2	Application ID Assignment Register	Run-time	400F4810
EMI	2	HOST-to-EC Mailbox Register		400F4900
EMI	2	EC-to-HOST Mailbox Register		400F4901
EMI	2	Memory Base Address 0 Register		400F4904
EMI	2	Memory Read Limit 0 Register		400F4908
EMI	2	Memory Write Limit 0 Register		400F490A
EMI	2	Memory Base Address 1 Register		400F490C
EMI	2	Memory Read Limit 1 Register		400F4910
EMI	2	Memory Write Limit 1 Register		400F4912
EMI	2	Interrupt Set Register		400F4914
EMI	2	Host Clear Enable Register		400F4916
EMI	2	Application ID Status 0 Register		400F4920
EMI	2	Application ID Status 1 Register		400F4924
EMI	2	Application ID Status 2 Register		400F4928
EMI	2	Application ID Status 3 Register		400F492C
EMI	2	Application ID Status 4 Register		400F4930

MEC1725

TABLE 3-5: REGISTER MAP

Block	Instance	Register	Host Type	Register Address
EMI	2	Application ID Status 5 Register		400F4934
EMI	2	Application ID Status 6 Register		400F4938
EMI	2	Application ID Status 7 Register		400F493C
Real Time Clock	0	Seconds Register	Run-time	400F5000
Real Time Clock	0	Seconds Alarm Register	Run-time	400F5001
Real Time Clock	0	Minutes Register	Run-time	400F5002
Real Time Clock	0	Minutes Alarm Register	Run-time	400F5003
Real Time Clock	0	Hours Register	Run-time	400F5004
Real Time Clock	0	Hours Alarm Register	Run-time	400F5005
Real Time Clock	0	Day of Week Register	Run-time	400F5006
Real Time Clock	0	Day of Month Register	Run-time	400F5007
Real Time Clock	0	Month Register	Run-time	400F5008
Real Time Clock	0	Year Register	Run-time	400F5009
Real Time Clock	0	Register A	Run-time	400F500A
Real Time Clock	0	Register B	Run-time	400F500B
Real Time Clock	0	Register C	Run-time	400F500C
Real Time Clock	0	Register D	Run-time	400F500D
Real Time Clock	0	Reserved	Run-time	400F500E
Real Time Clock	0	Reserved	Run-time	400F500F
Real Time Clock	0	RTC Control Register	Run-time	400F5010
Real Time Clock	0	Week Alarm Register	Run-time	400F5014
Real Time Clock	0	Daylight Savings Forward Register	Run-time	400F5018
Real Time Clock	0	Daylight Savings Backward Register	Run-time	400F501C
Real Time Clock	0	TEST	Run-time	400F5020
32-Bit BIOS Debug Port (Port 80) Base	0	Host Data Register	Run-time	400F8000
32-Bit BIOS Debug Port (Port 80) Base	0	EC Data Register		400F8100

TABLE 3-5: REGISTER MAP

Block	Instance	Register	Host Type	Register Address
32-Bit BIOS Debug Port (Port 80) Base	0	EC Data Attribute Register		400F8101
32-Bit BIOS Debug Port (Port 80) Base	0	Configuration Register		400F8104
32-Bit BIOS Debug Port (Port 80) Base	0	Status Register		400F8108
32-Bit BIOS Debug Port (Port 80) Base	0	Interrupt Enable Register		400F8109
32-Bit BIOS Debug Port (Port 80) Base	0	Snap Short Register		400F810C
32-Bit BIOS Debug Port (Port 80) Base	0	Capture Register		400F8110
32-Bit BIOS Debug Port (Port 80) Base	0	Activate Register	Config	400F8330
32-Bit BIOS Debug Port (Port 80) Alias	0	Host Data Register	Runtime	400F8400
32-Bit BIOS Debug Port (Port 80) Alias	0	Alias Activate Register	Config	400F8730
32-Bit BIOS Debug Port (Port 80) Alias	0	Alias Byte Lane Register	Config	400F87F0
eSPI Virtual Wires	0	MSVW00 Register	Runtime	400F9C00
eSPI Virtual Wires	0	MSVW01 Register	Runtime	400F9C0C
eSPI Virtual Wires	0	MSVW02 Register	Runtime	400F9C18
eSPI Virtual Wires	0	MSVW03 Register	Runtime	400F9C24
eSPI Virtual Wires	0	MSVW04 Register	Runtime	400F9C30
eSPI Virtual Wires	0	MSVW05 Register	Runtime	400F9C3C
eSPI Virtual Wires	0	MSVW06 Register	Runtime	400F9C48
eSPI Virtual Wires	0	MSVW07 Register	Runtime	400F9C54
eSPI Virtual Wires	0	MSVW08 Register	Runtime	400F9C60
eSPI Virtual Wires	0	MSVW09 Register	Runtime	400F9C6C
eSPI Virtual Wires	0	MSVW10 Register	Runtime	400F9C78
eSPI Virtual Wires	0	SMVW00 Register		400F9E00
eSPI Virtual Wires	0	SMVW01 Register		400F9E08
eSPI Virtual Wires	0	SMVW02 Register		400F9E10
eSPI Virtual Wires	0	SMVW03 Register		400F9E18
eSPI Virtual Wires	0	SMVW04 Register		400F9E20
eSPI Virtual Wires	0	SMVW05 Register		400F9E28

MEC1725

TABLE 3-5: REGISTER MAP

Block	Instance	Register	Host Type	Register Address
eSPI Virtual Wires	0	SMVW06 Register		400F9E30
eSPI Virtual Wires	0	SMVW07 Register		400F9E38
eSPI Virtual Wires	0	SMVW08 Register		400F9E40
eSPI Virtual Wires	0	SMVW09 Register		400F9E49
eSPI Virtual Wires	0	SMVW10 Register		400F9E50
eSPI Virtual Wires	0	TEST	Config	400F9F00
eSPI Virtual Wires	0	TEST	Config	400F9F02
eSPI Virtual Wires	0	TEST	Config	400F9F08
eSPI Virtual Wires	0	TEST	Config	400F9F0A
Global Configuration	0	Global Configuration Reserved	Run-time	400FFF00
Global Configuration	0	Control	Run-time	400FFF02
Global Configuration	0	Logical Device Number	Run-time	400FFF07
Global Configuration	0	Device Revision	Run-time	400FFF1C
Global Configuration	0	Device Sub ID	Run-time	400FFF1D
Global Configuration	0	Device ID[7:0]	Run-time	400FFF1E
Global Configuration	0	Device ID[15:0]	Run-time	400FFF1F
Global Configuration	0	Legacy Device ID	Run-time	400FFF20
Global Configuration	0	OTP ID	Run-time	400FFF24
Global Configuration	0	Validation ID	Run-time	400FFF25
Global Configuration	0	Boot ROM Revision ID[15:0]	Run-time	400FFF26
Global Configuration	0	TEST	Run-time	400FFF28
Global Configuration	0	TEST	Run-time	400FFF29
Global Configuration	0	Test0	Run-time	400FFF2A
Global Configuration	0	Test1	Run-time	400FFF2B
Global Configuration	0	TEST	Run-time	400FFF2C
Global Configuration	0	TEST	Run-time	400FFF2D

TABLE 3-5: REGISTER MAP

Block	Instance	Register	Host Type	Register Address
Global Configuration	0	TEST	Run-time	400FFF2E
Global Configuration	0	TEST	Run-time	400FFF2F
ARM M4F	0	Auxiliary_Control		DFFFE008
ARM M4F	0	SystemTick_Ctrl_Status		DFFFE010
ARM M4F	0	SystemTick_Reload_Value		DFFFE014
ARM M4F	0	SystemTick_Current_Value		DFFFE018
ARM M4F	0	SystemTick_Calibration_Value		DFFFE01C
ARM M4F	0	CPU_ID		DFFFE000
ARM M4F	0	Interrupt_Ctl_and_State		DFFFE004
ARM M4F	0	Vector_Table_Offset		DFFFE008
ARM M4F	0	Application_Interrupt_and_Reset_Ctl		DFFFE00C
ARM M4F	0	System_Ctl		DFFFE010
ARM M4F	0	Config_and_Ctl		DFFFE014
ARM M4F	0	System_Handler_Priority1		DFFFE018
ARM M4F	0	System_Handler_Priority2		DFFFE01C
ARM M4F	0	System_Handler_Priority3		DFFFE020
ARM M4F	0	System_Handler_Ctl_and_State		DFFFE024
ARM M4F	0	Configurable_Fault_Status		DFFFE028
ARM M4F	0	Hard_Fault_Status		DFFFE02C
ARM M4F	0	Debug_Fault_Status		DFFFE030
ARM M4F	0	Debug_Halting_Ctl_and_Status		DFFFE0F0
ARM M4F	0	Debug_Core_Register_Selector		DFFFE0F4
ARM M4F	0	Debug_Core_Register_Data		DFFFE0F8
ARM M4F	0	Debug_Exception_and_Monitor_Ctl		DFFFE0FC
ARM M4F	0	Bus_Fault_Address		DFFFE338
ARM M4F	0	Auxiliary_Fault_Status		DFFFE33C
ARM M4F	0	Processor_Feature0		DFFFE440
ARM M4F	0	Processor_Feature1		DFFFE444
ARM M4F	0	Debug_Features0		DFFFE448
ARM M4F	0	Auxiliary_Features0		DFFFE44C
ARM M4F	0	Memory_Model_Feature0		DFFFE550
ARM M4F	0	Memory_Model_Feature1		DFFFE554
ARM M4F	0	Memory_Model_Feature2		DFFFE558
ARM M4F	0	Memory_Model_Feature3		DFFFE55C
ARM M4F	0	Instruction_Set_Attributes0		DFFFE660
ARM M4F	0	Instruction_Set_Attributes1		DFFFE664
ARM M4F	0	Instruction_Set_Attributes2		DFFFE668
ARM M4F	0	Instruction_Set_Attributes3		DFFFE66C
ARM M4F	0	Instruction_Set_Attributes4		DFFFE670
ARM M4F	0	Coprocessor_Access_Ctl		DFFFE888
ARM M4F	0	Software_Triggered_Interrupt		DFFFEF00
Environmental Monitor	0	External Diode 1 Temperature Register		40200600

MEC1725

TABLE 3-5: REGISTER MAP

Block	Instance	Register	Host Type	Register Address
Environmental Monitor	0	Internal Temperature Register		40200602
Environmental Monitor	0	External Diode 2 Temperature Register		40200604
Environmental Monitor	0	External Diode 3 Temperature Register		40200606
Environmental Monitor	0	VIN Voltage Register		4020060E
Environmental Monitor	0	External Diode 1a Temperature Register		40200612
Environmental Monitor	0	External Diode 2a Temperature Register		40200614
Environmental Monitor	0	External Diode 3a Temperature Register		40200616
Environmental Monitor	0	External Diode 4a Temperature Register		40200618
Environmental Monitor	0	VCP Voltage Reading Register		40200621
Environmental Monitor	0	VTR Voltage Reading Register		40200622
Environmental Monitor	0	VTT Voltage Reading Register		40200623
Environmental Monitor	0	Temperature Configuration Register		4020062B
Environmental Monitor	0	Voltage Configuration Register		4020062D
Environmental Monitor	0	Thermistor Configuration Register		4020062E
Environmental Monitor	0	Temperature Conversion Configuration Register		4020062F
Environmental Monitor	0	Averaging Enable Register		40200630
Environmental Monitor	0	External Diode 1 Beta Configuration Register		40200638
Environmental Monitor	0	External Diode 2 Beta Configuration Register		40200639
Environmental Monitor	0	Lock Start Register		40200640
Environmental Monitor	0	Fault Interrupt Status Register		40200641
Environmental Monitor	0	Temp Interrupt Status Register		40200642
Environmental Monitor	0	ThermTrip Pin State Register		40200643
Environmental Monitor	0	Int Temp Interrupt Status Register		40200644
Environmental Monitor	0	Volt Interrupt Status Register		40200645
Environmental Monitor	0	VCP Low Limit Register		40200646
Environmental Monitor	0	VCP High Limit Register		40200647
Environmental Monitor	0	VTR Low Limit Register		40200648
Environmental Monitor	0	VTR High Limit Register		40200649
Environmental Monitor	0	VTT Low Limit Register		4020064A
Environmental Monitor	0	VTT High Limit Register		4020064B
Environmental Monitor	0	VIN Low Limit Register		4020064C
Environmental Monitor	0	VIN High Limit Register		4020064D
Environmental Monitor	0	External Diode 1 Temp Low Limit Register		4020064E
Environmental Monitor	0	External Diode 1 Temp High Limit Register		4020064F
Environmental Monitor	0	Internal Temp Low Limit Register		40200650
Environmental Monitor	0	Internal Temp High Limit Register		40200651
Environmental Monitor	0	External Diode 2 Temp Low Limit Register		40200652
Environmental Monitor	0	External Diode 2 Temp High Limit Register		40200653
Environmental Monitor	0	External Diode 3 Temp Low Limit Register		40200654
Environmental Monitor	0	External Diode 3 Temp High Limit Register		40200655
Environmental Monitor	0	External Diode 4 Temp Low Limit Register		40200656
Environmental Monitor	0	External Diode 4 Temp High Limit Register		40200657
Environmental Monitor	0	External Diode 1a Temp Low Limit Register		40200658
Environmental Monitor	0	External Diode 1a Temp High Limit Register		40200659

TABLE 3-5: REGISTER MAP

Block	Instance	Register	Host Type	Register Address
Environmental Monitor	0	External Diode 2a Temp Low Limit Register		4020065A
Environmental Monitor	0	External Diode 2a Temp High Limit Register		4020065B
Environmental Monitor	0	External Diode 3a Temp Low Limit Register		4020065C
Environmental Monitor	0	External Diode 3a Temp High Limit Register		4020065D
Environmental Monitor	0	External Diode 4a Temp Low Limit Register		4020065E
Environmental Monitor	0	External Diode 4a Temp High Limit Register		4020065F
Environmental Monitor	0	External Diode 3 Beta Configuration Register		40200664
Environmental Monitor	0	External Diode 4 Beta Configuration Register		40200665
Environmental Monitor	0	Internal Diode Beta Setting Register		40200667
Environmental Monitor	0	Conversion Seconds Rate Register		4020066C
Environmental Monitor	0	Conversion Rate Mode Register		4020066E
Environmental Monitor	0	REC Enable Register		40200670
Environmental Monitor	0	VSET Voltage Reading Register		40200671
Environmental Monitor	0	Thermal Trip Temperature Diode 1 Register		40200675
Environmental Monitor	0	FailSafe Status Register		40200676
Environmental Monitor	0	FailSafe Config Register		40200677
Environmental Monitor	0	Shutdown Status Register		40200678
Environmental Monitor	0	Shutdown Config Register		40200679
Environmental Monitor	0	Fault Interrupt Status Enable Register		4020067A
Environmental Monitor	0	Temp Interrupt Status Enable Register		4020067B
Environmental Monitor	0	Special Function Register		4020067C
Environmental Monitor	0	Int Temp Interrupt Status Enable Register		4020067D
Environmental Monitor	0	Volt Interrupt Status Enable Register		4020067E
Environmental Monitor	0	Thermal Trip Temperature Diode 2 Register		40200680
Environmental Monitor	0	Thermal Trip Temperature Diode 3 Register		40200681
Environmental Monitor	0	Thermal Trip Temperature Diode 4 Register		40200682
Environmental Monitor	0	Thermal Trip Temperature Diode 1a Register		40200683
Environmental Monitor	0	Thermal Trip Temperature Diode 2a Register		40200684
Environmental Monitor	0	Thermal Trip Temperature Diode 3a Register		40200685
Environmental Monitor	0	Thermal Trip Temperature Diode 4a Register		40200686
Environmental Monitor	0	Trim Adjust Ch1-4 Register		40200688
Environmental Monitor	0	Trim Adjust Ch1a-4a Register		4020068C
Environmental Monitor	0	Trim Adjust Internal Register		40200690
Environmental Monitor	0	Trim Adjust VCP Register		40200694
Environmental Monitor	0	Trim Adjust VIN Register		40200695
Environmental Monitor	0	Trim Adjust VTR Register		40200696
Environmental Monitor	0	Trim Adjust VTT Register		40200697
Environmental Monitor	0	TEST		402006C0
Environmental Monitor	0	Unlock Register		402006FC

MEC1725

4.0 POWER, CLOCKS, AND RESETS

4.1 Introduction

The [Power, Clocks, and Resets](#) (PCR) chapter identifies all the power supplies, clock sources, and reset inputs to the chip and defines all the derived power, clock, and reset signals. In addition, this section identifies Power, Clock, and Reset events that may be used to generate an interrupt event, as well as, the [Chip Power Management Features](#).

4.2 References

No references have been cited for this chapter.

4.3 Interrupts

The [Power, Clocks, and Resets](#) logic generates no events

4.4 Power

TABLE 4-1: POWER SOURCE DEFINITIONS

Power Well	Nominal Voltage	Description	Source
VTR_REG	1.8V - 3.3V	This supply is used to derive the chip's core power.	Pin Interface
VTR_ANALOG	3.3V	3.3V Analog Power Supply.	Pin Interface
VTR_PLL	3.3V	3.3V Power Supply for the 48MHz PLL. This must be connected to the same supply as VTR_ANALOG.	Pin Interface
VTR1	3.3V	3.3V System Power Supply. This is typically connected to the "Always-on" or "Suspend" supply rails in system. This supply must be on prior to the system RSMRST# signal being deasserted	Pin Interface
VTR2	3.3V or 1.8V	3.3V or 1.8V System Power Supply. This supply is used to power one bank of I/O pins. See Note 1 .	Pin Interface
VTR3	1.8V	1.8V System Power Supply. This supply is used to power one bank of I/O pins. See Note 1 .	Pin Interface
VTR_CORE	1.2V	The main power well for internal logic	Internal regulator
VBAT	3.0V - 3.3V	System Battery Back-up Power Well. This is the "coin-cell" battery. GPIOs that share pins with VBAT signals are powered by this supply.	Pin Interface VBAT
VSSx	0V	Digital Ground	Pin Interface

Note 1: See [Section 4.4.1, "I/O Rail Requirements"](#) for connection requirements for VTRx.
2: The source for the Internal regulator is [VTR_REG](#).
3: VTR refers to [VTR_REG](#) and [VTR_ANALOG](#).

4.4.1 I/O RAIL REQUIREMENTS

All pins are powered by four power supply pins: VBAT, VTR1, VTR2 and VTR3. The VBAT supply must be 3V to 3.6V maximum, as shown in the following section. The VTR1 is fixed 3.3V and VTR2 pins may be connected to either a 3.3V or a 1.8V power supply as configured by the firmware and VTR3 is fixed 1.8V.

If a power rail is not powered and stable when `RESET_SYS` is de-asserted and is not required for booting, software can configure the pins on that bank appropriately by setting the corresponding bit in the , once software can determine that the power supply is up and stable. All GPIOs in the bank must be left in their default state and not modified until the Bank Power is configured properly.

4.4.2 BATTERY CIRCUIT REQUIREMENTS

VBAT must always be present if `VTR_ANALOG` is present.

Microchip recommends removing all power sources to the device defined in [Table 4-1, "Power Source Definitions"](#) and all external voltage references defined in [Table 4-2, "Voltage Reference Definitions"](#) before removing and replacing the battery. In addition, upon removing the battery, discharge the battery pin before replacing the battery.

The following external circuit is recommended to fulfill this requirement:

FIGURE 4-1: RECOMMENDED BATTERY CIRCUIT

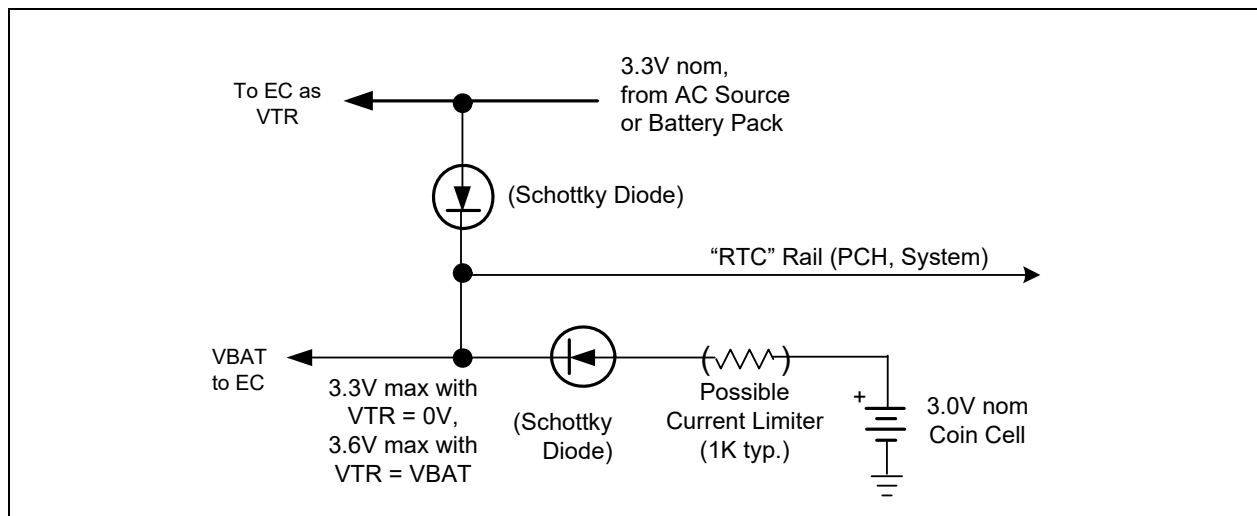

Note: During VBAT Power On Reset (VBAT POR), all VBAT IO pads are held in reset (tri-state) till the VBAT voltage inside the chip rises above 2.4V at the internal comparator. Therefore while inserting coin cell, only new coin cell that provide full 3.0V must be inserted. Once the VBAT voltage at the comparator reaches above 2.4V, the VBAT IO pads are brought out of reset and they work reliably till VBAT voltage is above 2.0V.

4.4.3 VOLTAGE REFERENCES

[Table 4-2](#) lists the External Voltage References to which the MEC1725 provides high impedance interfaces.

TABLE 4-2: VOLTAGE REFERENCE DEFINITIONS

Power Well	Nominal Input Voltage	Scaling Ratio	Nominal Monitored Voltage	Description	Source
VREF_VTT	Variable	n/a	Variable	Processor Voltage External Voltage Reference Used to scale Processor Interface signals. (See Note)	Pin Interface
VREF_ADC	Variable	n/a	Variable	ADC Reference Voltage	Pin Interface

Note: In order to achieve the lowest leakage current when both PECl and SB TSI are not used, set the [VREF_VTT Disable](#) bit to 1. This bit is defined in [PECl Disable Register](#) bit 0

MEC1725

4.4.4 POWER GOOD SIGNALS

The power good timing and thresholds are defined in the [Section 53.5, "VCC_PWRGD Timing"](#).

TABLE 4-3: POWER GOOD SIGNAL DEFINITIONS

Power Good Signal	Description	Source
VCC_PWRGD	VCC_PWRGD is an input signal used to indicate when the main system power rail voltage is on and stable.	Pin Interface
PWRGD_S0iX	PWRGD_S0iX is an input signal used to indicate when the alternate system power rail voltage is on and stable. This is used in the S0iX mode	Pin Interface
VCC_PWRGD2	VCC_PWRGD2 is an internal power good signal used to indicate whether the VCC power rail is good and stable.	Refer Power Good Function block diagram
VTR_PWRGD	VTR_PWRGD is an internal power good signal used to indicate whether the VTR_CORE rail is good and stable.	VTR_PWRGD is asserted following a delay after the VTR_CORE power well exceeds its preset voltage threshold.
PWROK	PWROK is an output signal used to indicate that the main system power rail voltage is on and the Host may access Host devices in the EC.	Refer System Reset Diagram for PWROK generation
PWRGD_STRAP	PWRGD_STRAP is an input signal that is asserted when the four Primary power rails in an Intel system (VCC_Prim 1.8V, VCC_Prim 3.3V, VCCPRIM_CORE and VCC_Prim 1.0V) are up. It is only used by Boot ROM code when booting over the eSPI Flash Channel.	GPIO227/SHD_IO2 pin. There is no special hardware associated with this signal

4.4.5 POWER GOOD EVENTS

Two input signals SLP_S0# and CPU_C10 is used to detect entry into Connected standby/S0 idle/S0ix System state. The power good input PWRGD_S0iX is added for signaling of Power good from an alternate power delivery path in S0ix mode. SLP_S0# and [PWRGD_S0iX](#) are always Physical pins. CPU_C10 may be a physical input or an eSPI virtual wire.

VCC_PWRGD2 is the internal power good signal and is function of two VCC power good inputs: [VCC_PWRGD](#) from the main power supply and [PWRGD_S0iX](#) from possible alternative power path in a low power VCC mode. The [PWROK](#) external pin is asserted high when VCC_PWRGD2 is asserted high and the [PWR_INV](#) bit in the [Power Reset Control Register](#) is deasserted low. Refer to [Section 50.0, "Glue \(VCC Power-Good Generation\) Logic"](#) for details about this functionality.

4.4.6 SYSTEM POWER SEQUENCING

The following table defines the behavior of the main power rails in each of the defined ACPI power states.

TABLE 4-4: TYPICAL POWER SUPPLIES VS. ACPI POWER STATES

Supply Name	ACPI Power State						Description
	S0 (FULL ON)	S1 (POS)	S3 (STR)	S4 (STD)	S5 (Soft Off)	G3 (MECH Off)	
VTR3	ON	ON	ON/OFF	ON/OFF	ON/OFF	OFF	1.8V Power Supply for Bank 3
VTR1	ON	ON	ON	ON	ON	OFF	"Always-on" Supply
VTR2	ON	ON	ON	ON	ON	OFF	3.3V/1.8V Power Supply for Bank 2
VBAT	ON	ON	ON	ON Note	ON Note	ON Note	Battery Back-up Supply

TABLE 4-4: TYPICAL POWER SUPPLIES VS. ACPI POWER STATES

Supply Name	ACPI Power State						Description
	S0 (FULL ON)	S1 (POS)	S3 (STR)	S4 (STD)	S5 (Soft Off)	G3 (MECH Off)	
<p>Note: This device requires that the VBAT power is on when the VTR(Note 3) power supply is on. External circuitry, a diode isolation circuit, is implemented on the motherboard to extend the battery life. This external circuitry ensures the VBAT pin will derive power from the VTR power well when it is on. Therefore, the VBAT supply will never appear to be off when the VTR rail is on.</p>							

TABLE 4-5: POWER SEQUENCING SIGNALS

Power Good Signal	Description	Source
SYSPWR_VALID	<p>SYSPWR_VALID is an input used to indicate that system power is within operational range. This signal is used to detect surprise shutdown event. This feature is disabled by default and may be enabled through OTP bit selection.</p> <p>low = system power not valid high = system power valid</p>	GPIO155 pin. There is no special hardware associated with this signal
DPWREN	<p>DSW Power Regulator Enable is an open drain output signal. This signal is driven low if a Surprise Power Down event is detected.</p> <p>low = DSW Power Regulator off high = DSW Power Regulator on</p>	There is no special hardware associated with this signal. The GPIO on which this output will be driven is configurable in the OTP. Any GPIO can be configured for this purpose.
DSW_PWRGD	<p>DSW Power Regulator Good is an input used to inform EC that the DSW Power Regulator voltage is within operational range.</p> <p>low = DSW Power Regulator output not valid high = DSW Power Regulator output valid</p>	There is no special hardware associated with this signal. The GPIO on which this output will be driven is configurable in the OTP. Any GPIO can be configured for this purpose.
DSW_PWROK	<p>DSW Power OK is an open drain output signal that indicates components on this rail can be released from reset. This signal is driven low if a Surprise Power Down event is detected.</p> <p>low = System components powered by DSW must be in reset high = System components powered by DSW may be released from reset</p>	There is no special hardware associated with this signal. The GPIO on which this output will be driven is configurable in the OTP. Any GPIO can be configured for this purpose.
SLP_SUS#	<p>SLP_SUS# is an input used to notify system when suspend power (i.e., Primary Rails) must be powered on or may be removed. This feature is disabled by default and may be enabled through OTP bit selection.</p> <p>low = Primary Rails are not ready to be powered on high = Primary Rails must be powered on</p>	There is no special hardware associated with this signal. The GPIO on which this output will be driven is configurable in the OTP. Any GPIO can be configured for this purpose.

TABLE 4-5: POWER SEQUENCING SIGNALS

Power Good Signal	Description	Source
SUS_PWR_EN	Primary Power Regulator Enable an open drain output signal that may be used to enable the Primary Power Regulator. This feature is disabled by default and may be enabled through OTP bit selection. This signal is driven low if a Surprise Power Down event is detected low = Primary Power Regulator off high = Primary Power Regulator on	There is no special hardware associated with this signal. The GPIO on which this output will be driven is configurable in the OTP. Any GPIO can be configured for this purpose.
PRIM_PWRGD	PRIM_PWRGD is an input signal that indicates that at least one primary rail is powered. For shared flash applications, it also indicates when the SPI Flash is powered and ready for EC access.	There is no special hardware associated with this signal. The GPIO on which this output will be driven is configurable in the OTP. Any GPIO can be configured for this purpose.
RSMRST#	RSMRST# is an open drain output that indicates all Primary power rails are valid and devices may be released from reset. This signal is driven low if a Surprise Power Down event is detected low = System components powered by Primary power rails must be in reset high = System components powered by Primary power rails may be released from reset	There is no special hardware associated with this signal. The GPIO on which this output will be driven is configurable in the OTP. Any GPIO can be configured for this purpose.
<p>Note: Power sequencing signals defined in this table are explained further in the Boot ROM document.</p> <p>Note: If power sequencing is enabled in OTP, the output signals require external pull-down resistors. The power sequencing output signals are: DPWREN, DSW_PWROK, SUS_PWR_EN, and RSMRST#. Please refer Boot ROM document for more details.</p>		
PWRGD_STRAP ^P	PWRGD_STRAP is an input signal that is asserted when the four Primary power rails in an Intel system (VCC_Prim 1.8V, VCC_Prim 3.3V, VCCPRIM_CORE and VCC_Prim 1.0V) are up. It is only used by Boot ROM code when booting over the eSPI Flash Channel.	GPIO227/SHD_IO2 pin. There is no special hardware associated with this signal

4.5 Clocks

The following section defines the clocks that are generated and derived.

4.5.1 RAW CLOCK SOURCES

The table defines raw clocks in the chip.

TABLE 4-6: SOURCE CLOCK DEFINITIONS

Clock Name	Frequency	Description	Source
32KHZ_IN	32.768 kHz (nominal)	Single-ended external clock input pin	32KHZ_IN pin
32.768 kHz Crystal Oscillator	32.768 kHz	A 32.768 kHz parallel resonant crystal connected between the XTAL1 and XTAL2 pins. The accuracy of the clock depends on the accuracy of the crystal and the characteristics of the analog components used as part of the oscillator The crystal oscillator source can bypass the crystal with a single-ended clock input. This option is configured with the VBAT SOURCE 32kHz Register .	Pin Interface (XTAL1 and XTAL2) When used singled-ended, pin XTAL2
32.768 kHz Silicon Oscillator	32.768 kHz	32.768 kHz low power Internal Oscillator. The frequency is 32.768KHz $\pm 2\%$.	Internal Oscillator powered by VBAT.
60 MHz Ring Oscillator	32MHz	The 60MHz Ring Oscillator is used to supply a clock for the 96MHz main clock domain while the 96MHz PLL is not locked. Its frequency can range from 32Mhz to 92MHz.	Powered by VTR_CORE .
96 MHz	96MHz	The 96 MHz Phase Locked Loop generates a 96 MHz clock locked to the 32KHz Clock Source	Powered by VTR_CORE . May be stopped by Chip Power Management Features .
48MHz	48MHz	The 48MHz clock is derived from the 96MHz	
eSPI Clock	20MHz to 50MHz	eSPI bus clock This clock is only used in the eSPI interface.	ESPI_CLK pin
SPI Clock	1MHz - 66MHz	This clock is used only in the SPI Slave interface	External SPI Master

4.5.2 CLOCK DOMAINS

TABLE 4-7: CLOCK DOMAIN DEFINITIONS

Clock Domain	Description
32KHz	The clock source used as reference for PLL lock and System Clock controls.
32KHz Core	The clock source used by internal blocks that require an always-on low speed clock
96MHz	The clock source used for system clock controls for divide down PLL or Dumb Ring Oscillator.
2MHz	Internally generated 2 MHz clock from 96MHz clock.
100KHz	A low-speed clock derived from the 48MHz clock domain. Used as a time base for PWMsand Tachs.
EC_CLK	The clock used by the EC processor. The frequency is determined by the Processor Clock Control Register .

MEC1725

TABLE 4-7: CLOCK DOMAIN DEFINITIONS (CONTINUED)

Clock Domain	Description
MCLK	The clock used by the Individual blocks. This can be 96MHz/48MHz dependent on the blocks and Turbo Clock Control register

4.5.3 SYSTEM CLOCK

The SYSTEM CLOCK referred to as MCLK widely in this document is sourced from the 96MHz PLL or Dumb Ring Oscillator.

The [MCLK](#) clock domain is primarily driven by a 96MHz PLL, which derives 96MHz from the 32KHz clock domain. In Heavy Sleep mode, the 96MHz PLL is shut off. When the PLL is started, either from waking from the Heavy Sleep mode, or after a Power On Reset, the 32MHz ring oscillator becomes the clock source for the [MCLK](#) clock domain until the PLL is stable. The PLL becomes stable after about 3ms; until that time, the 96MHz clock domain may range from 24MHz to 92MHz, as this is the accuracy range of the 60MHz ring. The 48MHz clock is derived from the 96MHz clock. [MCLK](#) can be configured to be 96MHz or 48MHz by setting Fast mode enable bit of [Turbo Clock Control](#) register

For achieving high performance the processor and PMC will run at 96MHz. The selection of 48MHz or 96MHz is done by configuring the [Fast mode enable](#) in the [Turbo Clock Control](#) register. Only the below mentioned blocks clock are controlled by the [Turbo Clock Control](#) register. All other blocks operate with 48MHz clock under normal S0 State.

- ARM
- PMC
- Memory
- QMSPI
- Crypto Blocks

All other blocks will be running using 48MHz clock.

The PLL requires its own power 3.3V power supply, VTR_PLL. This power rail must be active and stable no later than the latest of VTR_REG and VTR_ANALOG. There is no hardware detection of VTR_PLL power good in the reset generator.

4.5.4 32KHZ CLOCK SOURCE

The 32kHz Clock Domain may be sourced by a crystal oscillator, using an external crystal, by an 32kHz Internal oscillator, or from a single-ended clock input. The external single-ended clock source can itself be sourced either from the 32KHZ_IN signal that is a GPIO alternate function or from the XTAL2 crystal pin. The [VTR source 32kHz Clock Register](#) is used to configure the source for the 32 kHz clock domain. This clock source is used to drive the 96MHz PLL. Figure below represents the above information pictorially.

When [VTR_CORE](#) is off, the 32 kHz clock domain can be disabled, for lowest standby power, or it can be kept running in order to provide a clock for the Real Time Clock or the Week Timer.

An external single-ended clock input for 32KHZ_IN may be supplied by any accurate 32KHz clock source in the system. The SUSCLK output from the chipset may be used as the 32KHz source. SUSCLK must be present when VTR is on. See chipset documentation for details on the use of SUSCLK.

If firmware switches the 32KHz clock source, the 96MHz PLL will be shut off and then restarted. The [96MHz](#) clock domain will become unlocked and be sourced from the [60 MHz Ring Oscillator](#) until the [96 MHz](#) is on and locked.

4.5.5 32KHZ CORE CLOCK SOURCE

The 32KHz Core Internal Clock Source can be driven either by the [32.768 kHz Silicon Oscillator](#) or the [32.768 kHz Crystal Oscillator](#). The [VBAT SOURCE 32kHz Register](#) is used to configure the source for this 32 kHz clock domain. This clock is used by internal blocks that requires an always on low speed clock.

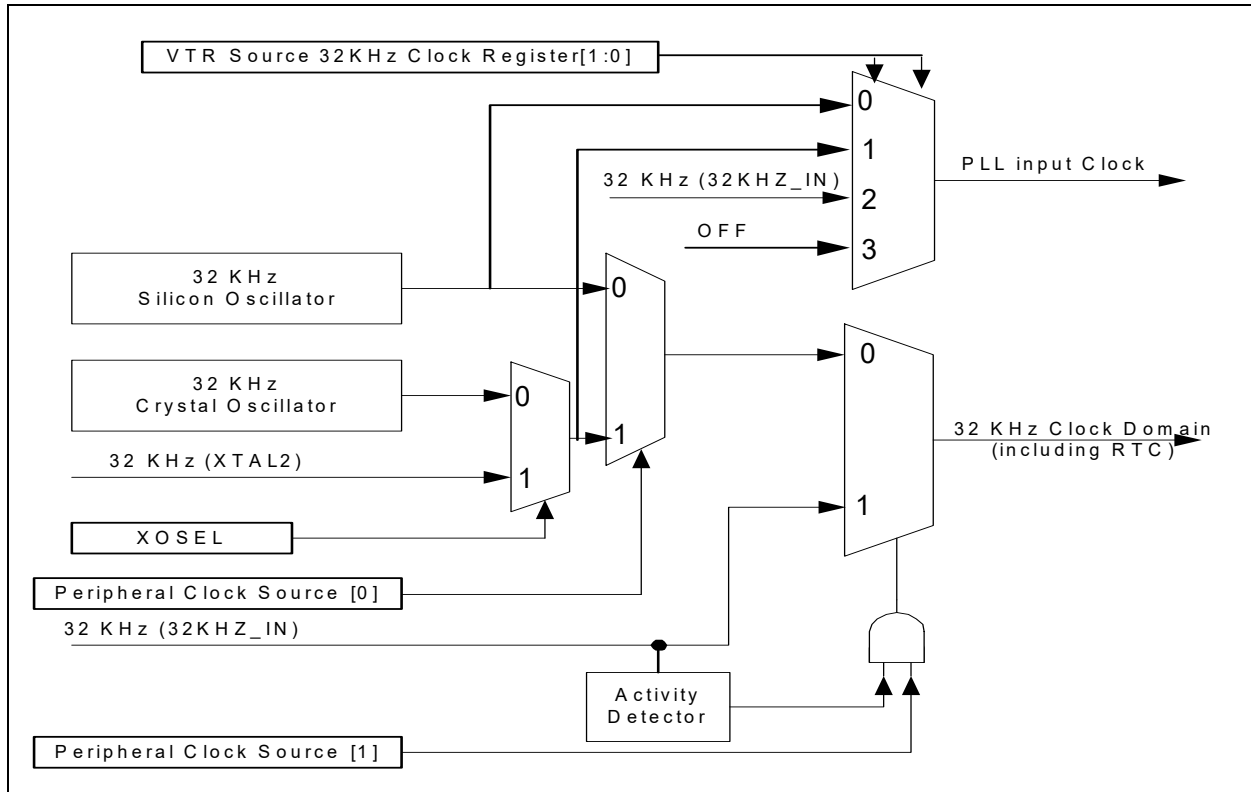

4.5.6 32KHZ CRYSTAL OSCILLATOR

An External Crystal Oscillator can be used with MEC1725 for sourcing the 32kHz clock domain. If the 32kHz source will never be the crystal oscillator, then the XTAL1 pin should be grounded. The XTAL2 pin should be left unconnected.

4.5.6.1 32KHz Crystal Oscillator Monitoring

This feature is optional and may be implemented in Application code. At power on the source for the 32kHz and 32kHz core will be the 32kHz Internal Oscillator. FW will monitor the external Crystal clock and may decide to switch the source of the 32kHz domain, if required, to the Crystal clock.

After a power on reset, the System clock source would run out of the [60 MHz Ring Oscillator](#) until the PLL is locked. The source clock for the PLL should be selected by configuring the [VTR source 32kHz Clock Register](#) to 32kHz Internal Silicon Oscillator. Using the 48MHz PLL clock locked to the internal Silicon Oscillator, measure the Crystal clock frequency and after N good pulses are detected in a row, clock monitor asserts interrupt to the EC and the status register gives the interrupt status. At this point FW can change the source to Crystal as the source for the PLL reference clock.

- On VBAT POR, everything is disabled.
 - System Clock is [60 MHz Ring Oscillator](#); all 32kHz Clock sources are OFF
- Boot ROM enables the Internal silicon oscillators 32kHz Clock and sets it as the PLL Reference
 - Once PLL is locked, System Clock is driven by the PLL; 32kHz PLL reference clock is from Internal Silicon Oscillator
- Application firmware enables XTAL
- Application firmware sets up Clock Monitor Counter limits and IRQ's
- Application firmware sets Time-out counter running in the background in case the clock is not within range.
- Application firmware enables XTAL Monitor Counter and XTAL Valid Counter
- Application firmware polls or waits for interrupt for XTAL to PASS or FAIL
- Application firmware switches PLL clock source to 32kHz XTAL clock, if it is Good.
 - Once PLL locks, System Clock is driven by PLL; 32kHz PLL reference clock is from XTAL
- Application firmware disables all Monitor Counters to save power.

MEC1725

4.6 Resets

TABLE 4-8: DEFINITION OF RESET SIGNALS

Reset	Description	Source
RESET_VBAT	Internal VBAT Reset signal. This signal is used to reset VBAT powered registers.	RESET_VBAT is a pulse that is asserted at the rising edge of VTR power if the VBAT voltage is below a nominal 1.25V. RESET_VBAT is also asserted as a level if, while VTR power is not present, the coin cell is replaced with a new cell that delivers at least a nominal 1.25V. In this latter case RESET_VBAT is de-asserted when VTR power is applied. No action is taken if the coin cell is replaced, or if the VBAT voltage falls below 1.25 V nominal, while VTR power is present.
RESET_VTR	Internal VTR Reset signal.	This internal reset signal is asserted as long as the reset generator determines that the output of the internal regulator is stable at its target voltage and that the voltage rail supplying the main clock PLL is at 3.3V. Although most VTR_CORE -powered registers are reset on RESET_SYS , some registers are only reset on this reset.
RESET_SYS	Internal Reset signal. This signal is used to reset VTR_CORE powered registers.	RESET_SYS is the main global reset signal. This reset signal will be asserted if: <ul style="list-style-type: none"> • RESET_VTR is asserted • The nRESET_IN pin asserted • A WDT Event event is asserted • A soft reset is asserted by the SOFT_SYS_RESET bit in the System Reset Register • ARM M4F SYSRESETREQ
RESET_eSPI	System reset signal connected to the eSPI ESPI_RESET# pin.	Pin Interface, ESPI_RESET# pin.
RESET_VCC	Performs a reset when Host power (VCC) is turned off	This signal is asserted if <ul style="list-style-type: none"> • RESET_SYS is asserted • VCC_PWRGD2 is low • The PWR_INV bit in the Power Reset Control Register is '1b' <p>The PWROK output pin is an inverted version of this reset; it is asserted when VCC_PWRGD2 is high and the PWR_INV bit is '0b'.</p> <p>Note: This reset is referred to as RESET_SIO in the eSPI Block Specification.</p>
RESET_HOST	Performs a reset when VCC_PWRGD2 is low or when the system host resets the Host Interface.	This signal is asserted if <ul style="list-style-type: none"> • RESET_SYS is asserted • VCC_PWRGD2 is low • The PWR_INV bit in the Power Reset Control Register is '1b' • eSPI_PLTRST# signal from the eSPI block is asserted.

TABLE 4-8: DEFINITION OF RESET SIGNALS (CONTINUED)

Reset	Description	Source
WDT Event	A WDT Event generates the RESET_SYS event. This signal resets VTR_CORE powered registers with the exception of the WDT Event Count Register register. Note that the glitch protect circuits do not activate on a WDT reset. WDT Event does not reset VBAT registers or logic.	This reset signal will be asserted if: <ul style="list-style-type: none"> A WDT Event event is asserted This event is indicated by the WDT bit in the Power-Fail and Reset Status Register
RESET_SYS_nWDT	Internal Reset signal. This signal is used to reset VTR_CORE powered registers not effected by a WDT Event A RESET_SYS_nWDT is used to reset registers that need to be preserved through a WDT Event like a WDT Event Count Register.	This reset signal will be asserted if: <ul style="list-style-type: none"> RESET_VTR is asserted The nRESET_IN pin asserted
RESET_EC	Internal reset signal to reset the processor in the EC Subsystem.	This reset is a stretched version of RESET_SYS. This reset asserts at the same time that RESET_SYS asserts and is held asserted for 1ms after RESET_SYS deasserts.
RESET_BLOCK_N	Each IP block in the device may be configured to be reset by setting the RESET_ENABLE register.	This reset signal will be asserted if Block N RESET_ENABLE is set to 1 and Peripheral Reset Enable n Register is unlocked.
Embedded Reset	Embedded reset would reset the EC if VCI_IN0# is held low for time programed in TIMEOUT register	Pin Interface, if enabled by Embedded Reset Enable register Note: Embedded reset feature if enabled will inhibit VCI_OUT getting asserted from any other logic viz. Power up events and VCI_INs

FIGURE 4-2: RESETS BLOCK DIAGRAM

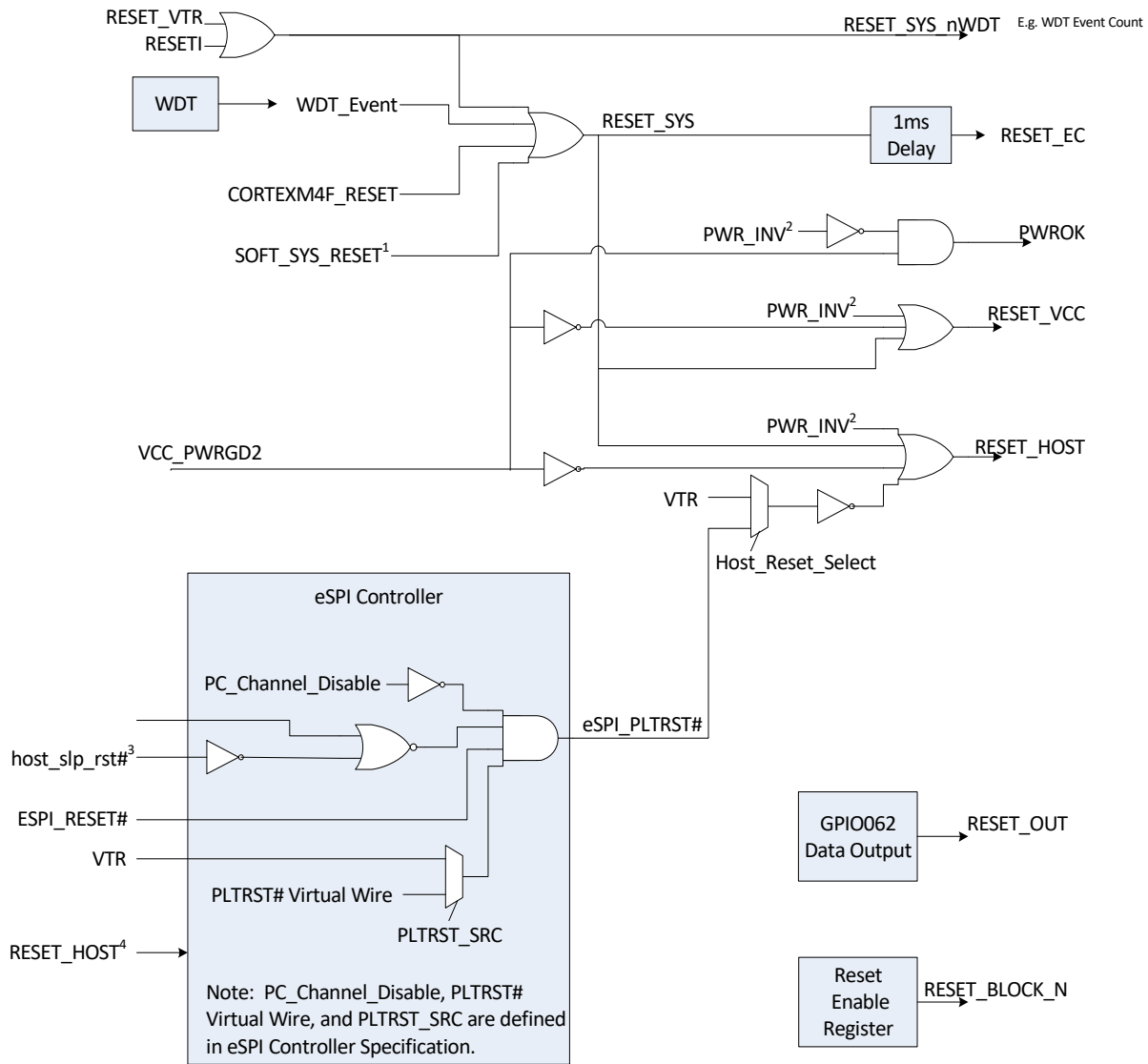

Note 1: SOFT_SYS_RESET is implemented in bit[8] of the System Reset Register

Note 2: PWR_INV is implemented in bit[0] of the Power Reset Control Register

Note 3: host_slp_rst# is asserted if the Host Sleep Enable bit and Host Reset Enable bit are set and the eSPI Controller is put to sleep

Note 4: RESET_HOST is fed back into the eSPI Controller to reset select registers/bits

4.7 Chip Power Management Features

This device is designed to always operate in its lowest power state during normal operation. In addition, this device offers additional programmable options to put individual logical blocks to sleep as defined in the following section, [Section 4.7.1](#).

4.7.1 BLOCK LOW POWER MODES

All power related control signals are generated and monitored centrally in the chip's Power, Clocks, and Resets (PCR) block. The power manager of the PCR block uses a sleep interface to communicate with all the blocks. The sleep interface consists of three signals:

- **SLEEP_ENABLE (request to sleep the block)** is generated by the PCR block. A group of SLEEP_ENABLE signals are generated for every clock segment. Each group consists of a SLEEP_ENABLE signal for every block in that clock segment.
- **CLOCK_REQUIRED (request clock on)** is generated by every block. They are grouped by blocks on the same clock segment. The PCR monitors these signals to see when it can gate off clocks.

A block can always drive CLOCK_REQUIRED low synchronously, but it *must* drive it high asynchronously since its internal clocks are gated and it has to assume that the clock input itself is gated. Therefore the block can only drive CLOCK_REQUIRED high as a result of a register access or some other input signal.

The following table defines a block's power management protocol:

TABLE 4-9: POWER MANAGEMENT PROTOCOL

Power State	SLEEP_ENABLE	CLOCK_REQUIRED	Description
Normal operation	Low	Low	Block is idle and NOT requesting clocks. The block gates its own internal clock.
Normal operation	Low	High	Block is NOT idle and requests clocks.
Request sleep	Rising Edge	Low	Block is IDLE and enters sleep mode immediately. The block gates its own internal clock. The block cannot request clocks again until SLEEP_ENABLE goes low.
Request sleep	Rising Edge	High then Low	Block is not IDLE and will stop requesting clocks and enter sleep when it finishes what it is doing. This delay is block specific, but should be less than 1 ms. The block gates its own internal clock. After driving CLOCK_REQUIRED low, the block cannot request clocks again until SLEEP_ENABLE goes low.
Register Access	X	High	Register access to a block is always available regardless of SLEEP_ENABLE. Therefore the block ungates its internal clock and drives CLOCK_REQUIRED high during the access. The block will regate its internal clock and drive CLOCK_REQUIRED low when the access is done.

A wake event clears all SLEEP_ENABLE bits momentarily, and then returns the SLEEP_ENABLE bits back to their original state. The block that needs to respond to the wake event will do so.

The Sleep Enable, Clock Required and Reset Enable Registers are defined in [Section 4.8](#).

4.7.2 CONFIGURING THE CHIP'S SLEEP STATES

The chip supports two sleep states: LIGHT SLEEP and HEAVY SLEEP. The chip will enter one of these two sleep states only when all the blocks have been commanded to sleep and none of them require a 96 MHz clock source (i.e., all CLOCK_REQUIRED status bits are 0), and the processor has executed its sleep instruction. These sleep states must be selected by firmware via the System Sleep Control bits implemented in the [System Sleep Control Register](#) prior to issuing the sleep instruction. [Table 4-11, "System Sleep Modes"](#) defines each of these sleep states.

There are two ways to command the chip blocks to enter sleep.

1. Assert the [SLEEP_ALL](#) bit located in the [System Sleep Control Register](#)
2. Assert all the individual block sleep enable bits

Blocks will only enter sleep after their sleep signal is asserted and they no longer require the 96 MHz source. Each block has a corresponding clock required status bit indicating when the block has entered sleep. The general operation is that a block will keep the 96 MHz clock source on until it completes its current transaction. Once the block has completed its work, it deasserts its clock required signal. Blocks like timers, PWMs, etc. will de-assert their clock required signals immediately. See the individual block Low Power Mode sections to determine how each individual block enters sleep.

4.7.3 DETERMINING WHEN THE CHIP IS SLEEPING

The TST_CLK_OUT pin can be used to verify the chip's clock has stopped, which indicates the device is in LIGHT SLEEP or HEAVY SLEEP, as determined by the [System Sleep Control Register](#). If the clock is toggling the chip is in the full on running state. If the clock is not toggling the chip has entered the programmed sleep state.

MEC1725

4.7.4 WAKING THE CHIP FROM SLEEPING STATE

The chip will remain in the configured sleep state until it detects either a wake event or a full [VTR_CORE](#) POR. A wake event occurs when a wake-capable interrupt is enabled and triggered. Interrupts that are not wake-capable cannot occur while the system is in LIGHT SLEEP or HEAVY SLEEP.

In LIGHT SLEEP, the [96 MHz](#) clock domain is gated off, but the [96 MHz](#) remains operational and locked to the [32KHz Core](#) clock domain. On wake, the PLL output is ungated and the [96 MHz](#) clock domain starts immediately, with the [PLL_LOCK](#) bit in the [Oscillator ID Register](#) set to '1'. Any device that requires an accurate clock, such as a UART, may be used immediately on wake.

In HEAVY SLEEP, the [96 MHz](#) is shut down. On wake, the [60 MHz Ring Oscillator](#) is used to provide a clock source for the [96 MHz](#) clock domain until the PLL locks to the [32KHz Core](#) clock domain. The ring oscillator starts immediately on wake, so there is no latency for the EC to start after a wake. However, the ring oscillator is only accurate to $\pm 50\%$, so any device that requires an accurate [96 MHz](#) clock will not operate correctly until the PLL locks. The time to lock latency for the PLL is shown in [Table 4-11, "System Sleep Modes"](#).

The [SLEEP_ALL](#) bit is automatically cleared when the processor responds to an interrupt. This applies to non-wake interrupts as well as wake interrupts, in the event an interrupt occurs between the time the processor issued a WAIT FOR INTERRUPT instruction and the time the system completely enters the sleep state.

4.7.4.1 Wake-Only Events

Some devices which respond to an external master require the [96 MHz](#) clock domain to operate but do not necessarily require and immediate processing by the EC. Wake-only events provide the means to start the [96 MHz](#) clock domain without triggering an EC interrupt service routine. This events are grouped into a single GIRQ, GIRQ22. Events that are enabled in that GIRQ will start the clock domain when the event occurs, but will not invoke an EC interrupt. The [SLEEP_ENABLE](#) flags all remain asserted. If the activity for the event does not in turn trigger another EC interrupt, the [CLOCK_REQUIRED](#) for the block will re-assert and the configured sleep state will be re-entered.

Note: For example, when RSMRST is high and there is a desire to wake from an ESPI cycle, GIRQ22[9] is the correct wake source to use. When Chip is asleep and there is a ESPI cycle, the falling edge of the CS will cause the chips clock to turn on the ESPI block, but not the processor itself. Upon conclusion of the ESPI cycle, if no ESPI interrupt was generated (i.e. most cycles), then the clock to the ESPI block will go off, and the chip will go back to sleep. If the ESPI cycle creates an interrupt to the processor (i.e. downstream wire or downstream OOB packet for example), then an processor interrupt will be generated if enabled and the clock will remain on and the processor can service the interrupt and the processor can put the chip back to sleep when it has completed its work.

4.8 EC Registers

Registers for this block are shown in the following summary table. Addresses for each register are determined by adding the offset to the Base Address for the [Power, Clocks, and Resets](#) Block in the Block Overview and Base Address Table in [Section 3.0, "Device Inventory"](#).

TABLE 4-10: REGISTER SUMMARY

Offset	Name
0h	System Sleep Control Register
4h	Processor Clock Control Register
8h	Slow Clock Control Register
Ch	Oscillator ID Register
10h	PCR Power Reset Status Register
14h	Power Reset Control Register
18h	System Reset Register
1Ch	Turbo Clock Control
20h	TEST
30h	Sleep Enable 0 Register
34h	Sleep Enable 1 Register
38h	Sleep Enable 2 Register

TABLE 4-10: REGISTER SUMMARY (CONTINUED)

Offset	Name
3Ch	Sleep Enable 3 Register
40h	Sleep Enable 4 Register
50h	Clock Required 0 Register
54h	Clock Required 1 Register
58h	Clock Required 2 Register
5Ch	Clock Required 3 Register
60h	Clock Required 4 Register
70h	Reset Enable 0 Register
74h	Reset Enable 1 Register
78h	Reset Enable 2 Register
7Ch	Reset Enable 3 Register
80h	Reset Enable 4 Register
84h	Peripheral Reset Lock Register
88h	VBAT Soft Reset Register
8Ch	VTR source 32kHz Clock Register
C0h	32kHz Period count Register
C4h	32kHz High pulse count Register
C8h	32kHz Period MIN count Register
CCh	32kHz Period MAX count Register
D0h	32kHz Duty Cycle variation Register
D4h	32kHz Duty Cycle variation Max Register
D8h	32kHz Valid Count Register
DCh	32kHz Valid Count MIN Register
E0h	32kHz Control Register
E4h	32kHz Source Interrupt Register
E8h	32kHz Source Interrupt ENABLE Register

All register addresses are naturally aligned on 32-bit boundaries. Offsets for registers that are smaller than 32 bits are reserved and must not be used for any other purpose.

The bit definitions for the Sleep Enable, Clock Required and Reset Enable Registers are defined in the Sleep Enable Register Assignments Table in [Table 3-2, "Sleep Allocation"](#).

MEC1725

4.9 Sleep Enable *n* Registers

4.9.1 SLEEP ENABLE *N* REGISTER

Offset	See Sleep Enable Register Assignments Table in Section 3.0, "Device Inventory"			
Bits	Description	Type	Default	Reset Event
31:0	<p>SLEEP_ENABLE</p> <p>1=Block is commanded to sleep at next available moment 0=Block is free to use clocks as necessary</p> <p>Unassigned bits are reserved. They must be set to '1b' when written. When read, unassigned bits return the last value written.</p>	R/W	0h	RESET_SYS

4.9.2 CLOCK REQUIRED *N* REGISTER

Offset	See Sleep Enable Register Assignments Table in Section 3.0, "Device Inventory"			
Bits	Description	Type	Default	Reset Event
31:0	<p>CLOCK_REQUIRED</p> <p>1=Block requires clocks 0=Block does not require clocks</p> <p>Unassigned bits are reserved and always return 0 when read.</p>	R	0h	RESET_SYS

4.9.3 PERIPHERAL RESET ENABLE *N* REGISTER

Offset	See Sleep Enable Register Assignments Table in Section 3.0, "Device Inventory"			
Bits	Description	Type	Default	Reset Event
31:0	<p>PERIPHERAL_RESET_ENABLE</p> <p>1= Will allow issue parallel reset to the peripherals. This is self clearing bit.</p>	W	0h	RESET_SYS

4.9.4 SYSTEM SLEEP CONTROL REGISTER

Offset	0h			
Bits	Description	Type	Default	Reset Event
31:9	Reserved	RES	-	-
8	<p>SLEEP_IMMEDIATE</p> <p>0 = System will only allow entry into sleep after PLL locks. 1 = System will allow entry into Heavy Sleep before PLL locks.</p> <p>Heavy Sleep : Any sleep state where the PLL is OFF. Light Sleep : Any sleep state where the PLL is ON.</p>	R/W	0h	RESET_SYS
7:4	Reserved	RES	-	-
3	<p>SLEEP_ALL</p> <p>By setting this bit to '1b' and then issuing a WAIT FOR INTERRUPT instruction, the EC can initiate the System Sleep mode. When no device requires the main system clock, the system enters the sleep mode defined by the field SLEEP_MODE.</p> <p>This bit is automatically cleared when the processor vectors to an interrupt.</p> <p>1=Assert all sleep enables 0=Do not sleep all</p>	R/W	0h	RESET_SYS
2	<p>TEST</p> <p>Test bit. Should always be written with a '0b'.</p>	R/W	0h	RESET_SYS
1	Reserved	RES	-	-
0	<p>SLEEP_MODE</p> <p>Sleep modes differ only in the time it takes for the 96 MHz clock domain to lock to 96 MHz. The wake latency in all sleep modes is 0ms. Table 4-11 shows the time to lock latency for the different sleep modes.</p> <p>1=Heavy Sleep 0=Light Sleep</p>	R/W	0h	RESET_SYS

TABLE 4-11: SYSTEM SLEEP MODES

SLEEP_MODE	Sleep State	Latency to Lock	Description
0	LIGHT SLEEP	0	Output of the PLL is gated in sleep. The PLL remains on.
1	HEAVY SLEEP	3ms	The PLL is shut down while in sleep.

MEC1725

4.9.5 PROCESSOR CLOCK CONTROL REGISTER

Offset	04h			
Bits	Description	Type	Default	Reset Event
31:8	Reserved	RES	-	-
7:0	<p>PROCESSOR_CLOCK_DIVIDE</p> <p>The following list shows examples of settings for this field and the resulting EC clock rate.</p> <p>48=divide the 96 MHz clock by 48(2MHz processor clock) 16=divide the 96 MHz clock by 16 (6MHz processor clock) 4=divide the 96 MHz clock by 4 (24MHz processor clock) 2=divide the 96 MHz clock by 2(48MHz processor clock) 1=divide the 96 MHz clock by 1 (96MHz processor clock) No other values are supported.</p>	R/W	4h	RESET_SYS

4.9.6 SLOW CLOCK CONTROL REGISTER

Offset	08h			
Bits	Description	Type	Default	Reset Event
31:10	Reserved	RES	-	-
9:0	<p>SLOW_CLOCK_DIVIDE</p> <p>Configures the 100KHz clock domain.</p> <p>n=Divide by n 0=Clock off</p> <p>The default setting is for 100KHz.</p>	R/W	1E0h	RESET_SYS

4.9.7 OSCILLATOR ID REGISTER

Offset	0Ch			
Bits	Description	Type	Default	Reset Event
31:9	Reserved	RES	-	-
8	<p>PLL_LOCK</p> <p>Phase Lock Loop Lock Status</p>	R	0h	RESET_SYS
7:0	TEST	R	N/A	RESET_SYS

4.9.8 PCR POWER RESET STATUS REGISTER

Offset	10h			
Bits	Description	Type	Default	Reset Event
31:13	Reserved	RES	-	-
11	<p>ESPI_CLK_ACTIVE</p> <p>This bit monitors the state of the eSPI clock input. This status bit detects edges on the clock input but does not validate the frequency.</p> <p>1=The eSPI clock is present. 0=The eSPI clock input is not present.</p>	R	-	RESET_SYS
10	<p>32K_ACTIVE</p> <p>1=The 32K clock input is present. 0=The 32K clock input is not present.</p>	R	-	RESET_SYS
9	Reserved	RES	-	-
8	<p>WDT_EVENT</p> <p>This bit allows the application code to determine WDT_EVENT against RESET_VTR</p>	R/W1C	0h	RESET_SYS-nWDT
7	<p>JTAG_RST#</p> <p>Indicates the JTAG_TRST# pin status.</p> <p>The JTAG TRST# input is gated off low when Boundary scan mode is enabled and will not be set in this mode.</p>	R	-	RESET_SYS
6	<p>RESET_SYS_STATUS</p> <p>Indicates the status of RESET_SYS.</p> <p>The bit will not clear if a write 1 is attempted at the same time that a RESET_VTR occurs; this way a reset event is never missed.</p> <p>1=A reset occurred 0=No reset occurred since the last time this bit was cleared</p>	R/WC	1h	RESET_SYS
5	<p>VBAT_RESET_STATUS</p> <p>Indicates the status of RESET_VBAT.</p> <p>The bit will not clear if a write of '1'b is attempted at the same time that a VBAT_RST_N occurs, this way a reset event is never missed.</p> <p>1=A reset occurred 0=No reset occurred while VTR_CORE was off or since the last time this bit was cleared</p>	R/WC	-	RESET_SYS
4	<p>RESET_VTR_STATUS</p> <p>Indicates the status of RESET_VTR event.</p>	R/W1C	1h	RESET_VTR
<p>Note 1: This read-only status bit always reflects the current status of the event and is not affected by any Reset events.</p>				

MEC1725

Offset	10h			
Bits	Description	Type	Default	Reset Event
3	RESET_HOST_STATUS Indicates the status of RESET_VCC . 1=Reset not active 0=Reset active	R	-	Note 1
2	VCC_PWRGD_STATUS Indicates the status of VCC_PWRGD . 1= VCC_PWRGD asserted 0= VCC_PWRGD not asserted	R	xh	Note 1
1:0	Reserved	RES	-	-
Note 1: This read-only status bit always reflects the current status of the event and is not affected by any Reset events.				

4.9.9 POWER RESET CONTROL REGISTER

Offset	14h			
Bits	Description	Type	Default	Reset Event
31:9	Reserved	RES	-	-
8	HOST_RESET_SELECT This bit determines the platform reset signal. It should be set to '0b' if the eSPI interface is in use. 1= Logic 1 0=The eSPI_PLTRST# signal from the eSPI block is used to generate the internal Platform Reset	R/W	1h	RESET_SYS
7:1	Reserved	RES	-	-
0	PWR_INV This bit allows firmware to control when the Host receives an indication that the VCC power is valid, by controlling the state of the PWROK pin. This bit is used by firmware to control the internal RESET_VCC signal function and the external PWROK pin. This bit is read-only when VCC_PWRGD is de-asserted low. The internal RESET_VCC signal is asserted when this bit is asserted even if the PWROK pin is configured as an alternate function.	R / R/W	1h	RESET_SYS

4.9.10 SYSTEM RESET REGISTER

Offset	18h			
Bits	Description	Type	Default	Reset Event
31:9	Reserved	RES	-	-
8	SOFT_SYS_RESET A write of a '1' to this bit will force an assertion of the RESET_SYS reset signal, resetting the device. A write of a '0' has no effect. Reads always return '0'.	W	-	-
7:0	Reserved	RES	-	-

4.9.11 TURBO CLOCK CONTROL

Offset	1Ch			
Bits	Description	Type	Default	Reset Event
31:3	Reserved	RES	-	-
2	Fast mode enable 0=48MHz Clock Operation 1=96MHz Clock Operation Only clock to QMSPi, ARM Processor, Memory, Crypto and PMC blocks are changed by this bit. All other peripherals run off the 48MHz clock.	R/W	0b	RESET_SYS
1:0	Reserved	RES	-	-

4.9.12 PERIPHERAL RESET LOCK REGISTER

Offset	84h			
Bits	Description	Type	Default	Reset Event
31:0	PCR_RST_EN_LOCK If the lock is enabled, the peripherals cannot be reset by writing to the Reset enable register. Once Unlocked the Registers remain in the unlocked state until FW re-locks it with the Lock pattern 0xA6382D4Dh = Lock Pattern 0xA6382D4Ch = Unlock Pattern	RW	A6382D4Dh	RESET_SYS

MEC1725

4.9.13 VBAT SOFT RESET REGISTER

Offset	88h			
Bits	Description	Type	Default	Reset Event
31:1	RESERVED	-	-	-
0	SOFT VBAT POR 0=Normal Operation 1=Soft VBAT Reset. This bit is self clearing.	RW	0h	RESET_VTR

4.9.14 VTR SOURCE 32KHZ CLOCK REGISTER

Offset	8Ch			
Bits	Description	Type	Default	Reset Event
31:2	RESERVED	-	-	-
1:0	PLL Reference Source 0=Internal Oscillator 1=XTAL 2=32kHz_IN VTR Pin 3=None (OFF) If set to 0x3, the PLL will not receive a reference clock and will be held in Reset	R/W	3h	RESET_SYS

4.9.15 32KHZ PERIOD COUNT REGISTER

Offset	C0h			
Bits	Description	Type	Default	Reset Event
15:0	32kHz Period Counter Counts System clock between 2 positive edges of a 32kHz Clock	RO	-	RESET_SYS

4.9.16 32KHZ HIGH PULSE COUNT REGISTER

Offset	C4h			
Bits	Description	Type	Default	Reset Event
15:0	32kHz High Counter Counts how many System clock cycles the 32kHz clock remains High	RO	-	RESET_SYS

4.9.17 32KHZ PERIOD MIN COUNT REGISTER

Offset	C8h			
Bits	Description	Type	Default	Reset Event
15:0	32kHz Period Minimum Counter This is the minimum period count that is acceptable for the 32kHz counter to flag a PASS status	R/W	0h	RESET_SYS

4.9.18 32KHZ PERIOD MAX COUNT REGISTER

Offset	CCh			
Bits	Description	Type	Default	Reset Event
15:0	32kHz Period Maximum Counter This is the maximum period count that is acceptable for the 32kHz counter to flag a PASS status	R/W	0h	RESET_SYS

4.9.19 32KHZ DUTY CYCLE VARIATION REGISTER

Offset	CCh			
Bits	Description	Type	Default	Reset Event
15:0	32kHz Duty Variation Counter This is the difference in system clocks between the 32kHz clocks High Pulse Width and its Low Pulse Width.	RO	-	RESET_SYS

MEC1725

4.9.20 32KHZ DUTY CYCLE VARIATION MAX REGISTER

Offset	D4h			
Bits	Description	Type	Default	Reset Event
15:0	32kHz Duty Variation Maximum This is the maximum variation allowed to generate a PASS condition for the 32kHz clock.	R/W	0h	RESET_SYS

4.9.21 32KHZ VALID COUNT REGISTER

Offset	D8h			
Bits	Description	Type	Default	Reset Event
7:0	32kHz Valid Count This counts the number of valid 32kHz periods and pulse width variations measured in a row. This count increments on a PASS and will reset on a FAIL.	RO	-	RESET_SYS

4.9.22 32KHZ VALID COUNT MIN REGISTER

Offset	DCh			
Bits	Description	Type	Default	Reset Event
7:0	32kHz Valid Count Minimum This is the minimum value of Counter 32kHz Valid Count that will flag the status Counter Valid.	R/W	0h	RESET_SYS

4.9.23 32KHZ CONTROL REGISTER

Offset	E0h			
Bits	Description	Type	Default	Reset Event
31:25	RESERVED	-	-	-
24	32kHz Clear Counters Clears the Counters	WO	0h	RESET_SYS
23:5	RESERVED	-	-	-
4	32kHz Source Selects the 32kHz Clock source that is to be measured 0=XTAL 1=Internal Oscillator	R/W	0h	RESET_SYS

Offset	E0h			
Bits	Description	Type	Default	Reset Event
3	RESERVED	-	-	-
2	32kHz Valid Enable Enables the 32kHz valid counter	R/W	0h	RESET_SYS
1	32kHz Duty Cycle Counter Enable Enables the Duty Counter and checks for the 32kHz off of the system clock.	R/W	0h	RESET_SYS
0	32kHz Period Counter Enable Enables the Period Counter and checks for the 32kHz off of the system clock.	R/W	0h	RESET_SYS

4.9.24 32KHZ SOURCE INTERRUPT REGISTER

Offset	E4h			
Bits	Description	Type	Default	Reset Event
31:7	RESERVED	-	-	-
6	32kHz Unwell Interrupt This interrupt is set if there is any type of failure on the counters while monitoring the 32kHz clock (period or duty variation) after the Counter 32kHz Valid has been set. This interrupt is disabled if the counters are disabled or cleared, and will only be re-enabled after the next Counter 32kHz Valid is set.	R/W1C	-	RESET_SYS
5	32kHz Valid Interrupt This interrupt is set after the Valid Count check passes.	R/W1C	-	RESET_SYS
4	32kHz Stall Interrupt This interrupt is set when the 32kHz clock period counter overflows.	R/W1C	-	RESET_SYS
3	32kHz Fail Interrupt This interrupt is set when either the period or duty variation checks fail on a 32kHz clock positive edge.	R/W1C	-	RESET_SYS
2	32kHz Pass Duty Interrupt This interrupt is set when the Duty Cycle Variation check passes on every 32kHz positive edge.	R/W1C	-	RESET_SYS
1	32kHz Pass Period Interrupt This interrupt is set when the period check passes on every 32kHz positive clock edge (passes Max/Min Period Check).	R/W1C	-	RESET_SYS
0	32kHz Pulse Ready Interrupt This interrupt is set on every positive edge of an 32kHz clock (after the 1st). This interrupt indicates that the status of the counters has been updated.	R/W1C	-	RESET_SYS

MEC1725

4.9.25 32KHZ SOURCE INTERRUPT ENABLE REGISTER

Offset	E8h			
Bits	Description	Type	Default	Reset Event
31:7	RESERVED	-	-	-
6	32kHz Unwell Interrupt Enable	R/W	0h	RESET_SYS
5	32kHz Valid Interrupt Enable	R/W	0h	RESET_SYS
4	32kHz Stall Interrupt Enable	R/W	0h	RESET_SYS
3	32kHz Fail Interrupt Enable	R/W	0h	RESET_SYS
2	32kHz Pass Duty Interrupt Enable	R/W	0h	RESET_SYS
1	32kHz Pass Period Interrupt Enable	R/W	0h	RESET_SYS
0	Counter 32kHz Pulse Ready Interrupt Enable	R/W	0h	RESET_SYS

5.0 ARM M4 BASED EMBEDDED CONTROLLER

5.1 Introduction

This chapter contains a description of the ARM M4 Embedded Controller (EC).

The EC is built around an ARM® Cortex®-M4F Processor provided by Arm Ltd. (the “ARM M4 IP”). The ARM Cortex® M4F is a full-featured 32-bit embedded processor, implementing the ARMv7-M THUMB instruction set and FPU instruction set in hardware.

The ARM M4 IP is configured as a Von Neumann, Byte-Addressable, Little-Endian architecture. It provides a single unified 32-bit byte-level address, for a total direct addressing space of 4GByte. It has multiple bus interfaces, but these express priorities of access to the chip-level resources (Instruction Fetch vs. Data RAM vs. others), and they do not represent separate addressing spaces.

The ARM M4 is configured as follows.

- **Little-Endian** byte ordering is selected at all times
- **Bit Banding** is included for efficient bit-level access
- **Floating-Point Unit (FPU)** is included, to implement the Floating-Point instruction set in hardware
- **Debug** features are included at “Ex+” level, defined as follows:
 - **DWT** Unit provides 4 Data Watchpoint comparators and Execution Monitoring
- **Trace** features are included at “Full” level, defined as follows:
 - **DWT** for reporting breakpoints and watchpoints
 - **ITM** for profiling and to timestamp and output messages from instrumented firmware builds
 - **ETM** for instruction tracing, and for enhanced reporting of Core and DWT events
 - The ARM-defined **HTM** trace feature is **not included**
- **NVIC** Interrupt controller with 8 priority levels and up to 240 individually-vectorized interrupt inputs
 - A Microchip-defined Interrupt Aggregator function (at chip level) may be used to group multiple interrupts onto single NVIC inputs
 - The ARM-defined **WIC** feature is **not included**. The Microchip Interrupt Aggregator function (at chip level) provides Wake control
- **MPU** (Memory Protection Unit) is included for memory access control Single entry **Write Buffer** is incorporated

5.2 References

1. ARM Limited: Cortex®-M4F Technical Reference Manual, DDI0439C, 29 June 2010
2. ARM Limited: ARM®v7-M Architecture Reference Manual, DDI0403D, November 2010
3. NOTE: Filename DDI0403D_arm_architecture_v7m_reference_manual_errata_markup_1_0.pdf
4. ARM® Generic Interrupt Controller Architecture version 1.0 Architecture Specification, IHI0048A, September 2008
5. ARM Limited: AMBA® Specification (Rev 2.0), IHI0011A, 13 May 1999
6. ARM Limited: AMBA® 3 AHB-Lite Protocol Specification, IHI0033A, 6 June 2006
7. ARM Limited: AMBA® 3 ATB Protocol Specification, IHI0032A, 19 June 2006
8. ARM Limited: Cortex-M™ System Design Kit Technical Reference Manual, DDI0479B, 16 June 2011
9. ARM Limited: CoreSight™ v1.0 Architecture Specification, IHI0029B, 24 March 2005
10. ARM Limited: CoreSight™ Components Technical Reference Manual, DDI0314H, 10 July 2009
11. ARM Limited: ARM® Debug Interface v5 Architecture Specification, IHI0031A, 8 February 2006
12. ARM Limited: ARM® Debug Interface v5 Architecture Specification ADIV5.1 Supplement, DSA09-PRDC-008772, 17 August 2009
13. ARM Limited: Embedded Trace Macrocell™ (ETMv1.0 to ETMv3.5) Architecture Specification, IHI0014Q, 23 September 2011
14. ARM Limited: CoreSight™ ETM™-M4F Technical Reference Manual, DDI0440C, 29 June 2010

5.3 Terminology

5.3.1 ARM IP TERMS AND ACRONYMS

- **AHB**

Advanced High-Performance Bus, a system-level on-chip **AMBA 2** bus standard. See Reference[5], [ARM Limited: AMBA® Specification \(Rev 2.0\), IHI0011A, 13 May 1999](#).
- **AHB-AP**

AHB Access Port, the **AP** option selected by Microchip for the **DAP**
- **AHB-Lite**

A Single-Master subset of the **AHB** bus standard: defined in the **AMBA 3** bus standard. See Reference[6], [ARM Limited: AMBA® 3 AHB-Lite Protocol Specification, IHI0033A, 6 June 2006](#).
- **AMBA**

The collective term for bus standards originated by ARM Limited.
AMBA 3 defines the IP's **AHB-Lite** and **ATB** bus interfaces.
AMBA 2 (AMBA Rev. 2.0) defines the EC's **AHB** bus interface.
- **AP**

Any of the ports on the **DAP** subblock for accessing on-chip resources on behalf of the Debugger, independent of processor operations. A single **AHB-AP** option is currently selected for this function.
- **APB**

Advanced Peripheral Bus, a limited 32-bit-only bus defined in **AMBA 2** for I/O register accesses. This term is relevant only to describe the **PPB** bus internal to the EC core. See Reference [5], [ARM Limited: AMBA® Specification \(Rev 2.0\), IHI0011A, 13 May 1999](#).
- **ARMv7**

The identifying name for the general architecture implemented by the **Cortex-M** family of IP products.
The **ARMv7** architecture has no relationship to the older “ARM 7” product line, which is classified as an “ARMv3” architecture, and is very different.
- **ATB**

Interface standard for Trace data to the **TPIU** from **ETM** and/or **ITM** blocks, Defined in **AMBA 3**. See Reference[7], [ARM Limited: AMBA® 3 ATB Protocol Specification, IHI0032A, 19 June 2006](#).
- **Cortex-M4F**

The ARM designation for the specific IP selected for this product: a Cortex M4F processor core containing a hardware Floating Point Unit (FPU)
- **DAP**

Debug Access Port, a subblock consisting of **DP** and **AP** subblocks.
- **DP**

Any of the ports in the **DAP** subblock for connection to an off-chip Debugger. A single **SWJ-DP** option is currently selected for this function, providing **JTAG** connectivity.
- **DWT**

Data Watchdog and Trace subblock. This contains comparators and counters used for data watchpoints and Core activity tracing.
- **ETM**

Embedded Trace Macrocell subblock. Provides enhancements for Trace output reporting, mostly from the **DWT** subblock. It adds enhanced instruction tracing, filtering, triggering and timestamping.
- **FPB**

FLASH Patch Breakpoint subblock. Provides either Remapping (Address substitution) or Breakpointing (Exception or Halt) for a set of Instruction addresses and Data addresses. See Section 8.3 of Reference [1], [ARM Limited: Cortex®-M4F Technical Reference Manual, DDI0439C, 29 June 2010](#).

- FPU
Floating-Point Unit: a subblock included in the Core for implementing the Floating Point instruction set in hardware.
- HTM
AHB Trace Macrocell. This is an optional subblock that is **not included**.
- ITM
Instrumentation Trace Macrocell subblock. Provides a HW Trace interface for "printf"-style reports from instrumented firmware builds, with timestamping also provided.
- MEM-AP
A generic term for an **AP** that connects to a memory-mapped bus on-chip. For this product, this term is synonymous with the AHB Access Port, **AHB-AP**.
- MPU
Memory Protection Unit.
- NVIC
Nested Vectored Interrupt Controller subblock. Accepts external interrupt inputs. See References [2], [ARM Limited: ARM@v7-M Architecture Reference Manual, DDI0403D, November 2010](#) and [4], [ARM@ Generic Interrupt Controller Architecture version 1.0 Architecture Specification, IHI0048A, September 2008](#).
- PPB
Private Peripheral Bus: A specific **APB** bus with local connectivity within the EC.
- ROM Table
A ROM-based data structure in the Debug section that allows an external Debugger and/or a FW monitor to determine which of the Debug features are present.
- SWJ-DP
Serial Wire / **JTAG** Debug Port, the **DP** option selected by Microchip for the **DAP**.
- TPA
Trace Port Analyzer: any off-chip device that uses the TPIU output.
- TPIU
Trace Port Interface Unit subblock. Multiplexes and buffers Trace reports from the ETM and ITM subblocks.
- WIC
Wake-Up Interrupt Controller. This is an optional subblock that is **not included**.

5.3.2 MICROCHIP TERMS AND ACRONYMS

- Interrupt Aggregator
This is a module that may be present at the chip level, which can combine multiple interrupt sources onto single interrupt inputs at the EC, causing them to share a vector.
- PMU
Processor Memory Unit, this is a module that may be present at the chip level containing any memory resources that are closely-coupled to the MEC1725 EC. It manages accesses from both the EC processor and chip-level bus masters.

5.4 ARM M4 IP Interfaces

This section defines only the interfaces to the ARM IP itself. For the interfaces of the entire block, see [Section 5.5, "Block External Interfaces"](#).

The MEC1725 IP has the following major external interfaces, as shown in [Figure 5-1, "ARM M4 Based Embedded Controller I/O Block Diagram"](#):

- ICode AHB-Lite Interface
- DCode AHB-Lite Interface
- System AHB-Lite Interface

MEC1725

- Debug (JTAG) Interface
- Trace Port Interface
- Interrupt Interface

The EC operates on the model of a single 32-bit addressing space of byte addresses (4Gbytes, Von Neumann architecture) with Little-Endian byte ordering. On the basis of an internal decoder (part of the Bus Matrix shown in [Figure 5-1](#)), it routes Read/Write/Fetch accesses to one of three external interfaces, or in some cases internally (shown as the PPB interface).

The EC executes instructions out of closely-coupled memory via the ICode Interface. Data accesses to closely-coupled memory are handled via the DCode Interface. The EC accesses the rest of the on-chip address space via the System AHB-Lite interface. The Debugger program in the host can probe the EC and all EC addressable memory via the JTAG debug interface.

Aliased addressing spaces are provided at the chip level so that specific bus interfaces can be selected explicitly where needed. For example, the EC's Bit Banding feature uses the System AHB-Lite bus to access resources normally accessed via the DCode or ICode interface.

<p>Note: The EC executes most instructions in one clock cycle. If an instruction accesses code and data that are in different RAM blocks, then it takes one clock cycle to access both code and data (done in parallel). However, if the code and data blocks are in the same RAM block, then it takes two clock cycles (one clock for code access and one clock for data access) since it must do it sequentially.</p>

5.5 Block External Interfaces

FIGURE 5-1: ARM M4F BASED EMBEDDED CONTROLLER I/O BLOCK DIAGRAM

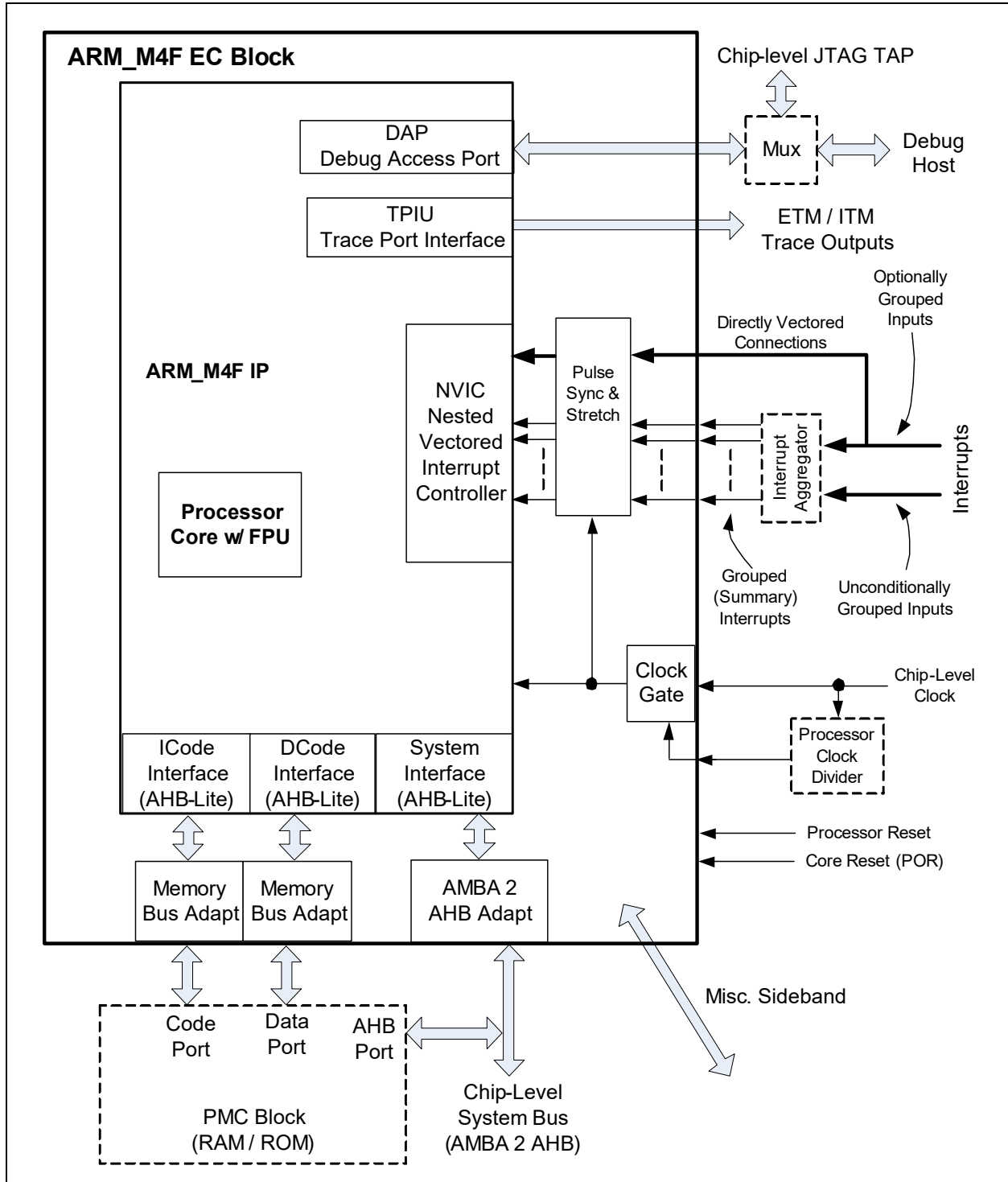

MEC1725

5.6 Power, Clocks and Reset

This section defines the Power, Clock, and Reset parameters of the block.

5.6.1 POWER DOMAINS

TABLE 5-1: POWER SOURCES

Name	Description
VTR_CORE	The ARM M4 Based Embedded Controller is powered by VTR_CORE.

5.6.2 CLOCK INPUTS

5.6.2.1 Basic Clocking

The basic clocking comes from a free-running Clock signal provided from the chip level.

TABLE 5-2: CLOCK INPUTS

Name	Description
96 MHz	The clock source to the EC. Division of the clock rate is determined by the PROCESSOR_CLOCK_DIVIDE field in the Processor Clock Control Register .

5.6.2.2 System Tick Clocking

The System Tick clocking is controlled by a signal from chip-level logic. It is the 96 MHz divided by the following:

$$- ((\text{PROCESSOR_CLOCK_DIVIDE}) \times 2) + 1$$

5.6.2.3 Debug JTAG Clocking

The Debug JTAG clocking comes from chip-level logic, which may multiplex or gate this clock. See [Section 5.10, "Debugger Access Support"](#).

5.6.2.4 Trace Clocking

The Clock for the Trace interface is identical to the 96 MHz input.

5.6.3 RESETS

The reset interface from the chip level is given below.

TABLE 5-3: RESET SIGNALS

Name	Description
RESET_EC	The ARM M4 Based Embedded Controller is reset by RESET_EC.

5.7 Interrupts

The [ARM M4 Based Embedded Controller](#) is equipped with an Interrupt Interface to respond to interrupts. These inputs go to the IP's NVIC block after a small amount of hardware processing to ensure their detection at varying clock rates. See [Figure 5-1, "ARM M4 Based Embedded Controller I/O Block Diagram"](#).

As shown in [Figure 5-1](#), an Interrupt Aggregator block may exist at the chip level, to allow multiple related interrupts to be grouped onto the same NVIC input, and so allowing them to be serviced using the same vector. This may allow the same interrupt handler to be invoked for a group of related interrupt inputs. It may also be used to expand the total number of interrupt inputs that can be serviced.

The NMI (Non-Maskable Interrupt) connection is tied off and not used.

5.7.1 NVIC INTERRUPT INTERFACE

The NVIC interrupt unit can be wired to up to 240 interrupt inputs from the chip level. The interrupts that are actually connected from the chip level are defined in the Interrupt section.

All NVIC interrupt inputs can be programmed as either pulse or level triggered. They can also be individually masked, and individually assigned to their own hardware-managed priority level.

5.7.2 NVIC RELATIONSHIP TO EXCEPTION VECTOR TABLE ENTRIES

The Vector Table consists of 4-byte entries, one per vector. Entry 0 is not a vector, but provides an initial Reset value for the Main Stack Pointer. Vectors start with the Reset vector, at Entry #1. Entries up through #15 are dedicated for internal exceptions, and do not involve the NVIC.

NVIC entries in the Vector Table start with Entry #16, so that NVIC Interrupt #0 is at Entry #16, and all NVIC interrupt numbers are incremented by 16 before accessing the Vector Table.

The number of connections to the NVIC determines the necessary minimum size of the Vector Table, as shown below. It can extend as far as 256 entries (255 vectors, plus the non-vector entry #0).

A Vector entry is used to load the Program Counter (PC) and the EPSR.T bit. Since the Program Counter only expresses code addresses in units of two-byte Halfwords, bit[0] of the vector location is used to load the EPSR.T bit instead, selecting THUMB mode for exception handling. Bit[0] must be '1' in all vectors, otherwise a UsageFault exception will be posted (INVSTATE, unimplemented instruction set). If the Reset vector is at fault, the exception posted will be HardFault instead.

TABLE 5-4: EXCEPTION AND INTERRUPT VECTOR TABLE LAYOUT

Table Entry	Exception Number	Exception
Special Entry for Reset Stack Pointer		
0	(none)	Holds Reset Value for the Main Stack Pointer. Not a Vector.
Core Internal Exception Vectors start here		
1	1	Reset Vector (PC + EPSR.T bit)
2	2	NMI (Non-Maskable Interrupt) Vector
3	3	HardFault Vector
4	4	MemManage Vector
5	5	BusFault Vector
6	6	UsageFault Vector
7	(none)	(Reserved by ARM Ltd.)
8	(none)	(Reserved by ARM Ltd.)
9	(none)	(Reserved by ARM Ltd.)
10	(none)	(Reserved by ARM Ltd.)
11	11	SVCall Vector
12	12	Debug Monitor Vector
13	(none)	(Reserved by ARM Ltd.)
14	14	PendSV Vector
15	15	SysTick Vector
NVIC Interrupt Vectors start here		
16	16	NVIC Interrupt #0 Vector
.	.	.
.	.	.
.	.	.
n + 16	n + 16	NVIC Interrupt #n Vector
.	.	.
.	.	.
.	.	.
max + 16	max + 16	NVIC Interrupt #max Vector (Highest-numbered NVIC connection.)
.	.	. Table size may (but need not) extend further.
.	.	.
.	.	.
255	255	NVIC Interrupt #239 (Architectural Limit of Exception Table)

5.8 Low Power Modes

The ARM processor can enter Sleep or Deep Sleep modes internally. This action will cause an output signal Clock Required to be turned off, allowing clocks to be stopped from the chip level. However, Clock Required will still be held active, or set to active, unless all of the following conditions exist:

- No interrupt is pending.
- An input signal Sleep Enable from the chip level is active.
- The Debug JTAG port is inactive (reset or configured not present).

In addition, regardless of the above conditions, a chip-level input signal [Force Halt](#) may halt the processor and remove Clock Required.

5.9 Description

5.9.1 BUS CONNECTIONS

There are three bus connections used from MEC1725 EC block, which are directly related to the IP bus ports. See [Figure 5-1, "ARM M4 Based Embedded Controller I/O Block Diagram"](#).

For the mapping of addresses at the chip level, see [Section 3.0, "Device Inventory"](#).

5.9.1.1 Closely Coupled Instruction Fetch Bus

As shown in [Figure 5-1](#), the AHB-Lite ICode port from the IP is converted to a more conventional SRAM memory-style bus and connected to the on-chip memory resources with routing priority appropriate to Instruction Fetches.

5.9.1.2 Closely Coupled Data Bus

As shown in [Figure 5-1](#), the AHB-Lite DCode port from the IP is converted to a more conventional SRAM memory-style bus and connected to the on-chip memory resources with routing priority appropriate to fast Data Read/Write accesses.

5.9.1.3 Chip-Level System Bus

As shown in [Figure 5-1](#), the AHB-Lite System port from the IP is converted from AHB-Lite to fully arbitrated multi-master capability (the AMBA 2 defined AHB bus: see Reference [5], [ARM Limited: AMBA® Specification \(Rev 2.0\), IHI0011A, 13 May 1999](#)). Using this bus, all addressable on-chip resources are available. The multi-mastering capability supports the Microchip DMA and EMI features if present, as well as the Bit-Banding feature of the IP itself.

As also shown in [Figure 5-1](#), the Closely-Coupled memory resources are also available through this bus connection using aliased addresses. This is required in order to allow Bit Banding to be used in these regions, but it also allows them to be accessed by DMA and other bus masters at the chip level.

<p>Note: Registers with properties such as Write-1-to-Clear (W1C), Read-to-Clear and FIFOs need to be handled with appropriate care when being used with the bit band alias addressing scheme. Accessing such a register through a bit band alias address will cause the hardware to perform a read-modify-write, and if a W1C-type bit is set, it will get cleared with such an access. For example, using a bit band access to the Interrupt Aggregator, including the Interrupt Enables and Block Interrupt Status to clear an IRQ will clear all active IRQs.</p>
--

5.9.2 INSTRUCTION PIPELINING

There are no special considerations except as defined by ARM documentation.

5.10 Debugger Access Support

An external Debugger accesses the chip through a JTAG standard interface. The ARM Debug Access Port supports both the 2-pin SWD (Serial Wire Debug) interface and the 4-pin JTAG interface.

As shown in [Figure 5-1, "ARM M4 Based Embedded Controller I/O Block Diagram"](#), other resources at the chip level that share the JTAG port pins; for example chip-level Boundary Scan.

By default, debug access is disabled when the EC begins executing code. EC code enables debugging by writing the [Debug Enable Register](#) in the [EC Subsystem Registers](#) block.

TABLE 5-5: ARM JTAG ID

ARM Debug Mode	JTAG ID
SW-DP (2-wire)	0x2BA01477
JTAG (4-wire)	0x4BA00477

5.10.1 DEBUG AND ACCESS PORTS (SWJ-DP AND AHB-AP SUBBLOCKS)

These two subblocks work together to provide access to the chip for the Debugger using the Debug JTAG connection, as described in Chapter 4 of the [ARM Limited: ARM® Debug Interface v5 Architecture Specification, IHI0031A, 8 February 2006](#).

5.10.2 BREAKPOINT, WATCHPOINT AND TRACE SUPPORT

See References [11], [ARM Limited: ARM® Debug Interface v5 Architecture Specification, IHI0031A, 8 February 2006](#) and [12], [ARM Limited: ARM® Debug Interface v5 Architecture Specification ADiv5.1 Supplement, DSA09-PRDC-008772, 17 August 2009](#). A summary of functionality follows.

Breakpoint and Watchpoint facilities can be programmed to do one of the following:

- Halt the processor. This means that the external Debugger will detect the event by periodically polling the state of the EC.
- Transfer control to an internal Debug Monitor firmware routine, by triggering the Debug Monitor exception (see [Table 5-4, "Exception and Interrupt Vector Table Layout"](#)).

5.10.2.1 Instrumentation Support (ITM Subblock)

The Instrumentation Trace Macrocell (ITM) is for profiling software. This uses non-blocking register accesses, with a fixed low-intrusion overhead, and can be added to a Real-Time Operating System (RTOS), application, or exception handler. If necessary, product code can retain the register access instructions, avoiding probe effects.

5.10.2.2 HW Breakpoints and ROM Patching (FPB Subblock)

The Flash Patch and Breakpoint (FPB) block. This block can remap sections of ROM, typically Flash memory, to regions of RAM, and can set breakpoints on code in ROM. This block can be used for debug, and to provide a code or data patch to an application that requires field updates to a product in ROM.

5.10.2.3 Data Watchpoints and Trace (DWT Subblock)

The Debug Watchpoint and Trace (DWT) block provides watchpoint support, program counter sampling for performance monitoring, and embedded trace trigger control.

5.10.2.4 Trace Interface (ETM and TPIU)

The Embedded Trace Macrocell (ETM) provides instruction tracing capability. For details of functionality and usage, see References [13], [ARM Limited: Embedded Trace Macrocell™ \(ETMv1.0 to ETMv3.5\) Architecture Specification, IHI0014Q, 23 September 2011](#) and [14], [ARM Limited: CoreSight™ ETM™-M4F Technical Reference Manual, DDI0440C, 29 June 2010](#).

The Trace Port Interface Unit (TPIU) provides the external interface for the ITM, DWT and ETM.

MEC1725

5.11 Delay Register

5.11.1 DELAY REGISTER

Offset	0800_0000h			
Bits	Description	Type	Default	Reset Event
31:5	Reserved	RES	-	-
4:0	<p>DELAY</p> <p>Writing a value n, from 0h to 31h, to this register will cause the ARM processor to stall for $(n+1)$ microseconds (that is, from 1μS to 32μS).</p> <p>Reads will return the last value read immediately. There is no delay.</p>	R/W	0h	RESET_ SYS

6.0 RAM AND ROM

6.1 SRAM

The MEC1725 contains two blocks of SRAM. Both SRAM blocks can be used for either program or data accesses. Performance is enhanced when program fetches and data accesses are to different SRAM blocks, but a program will operate correctly even if both program and data accesses are targeting the same block simultaneously.

Depending on the device, the first SRAM, which is optimized for code access, is

- 320kB

The second SRAM, which is optimized for data access, is

- 64KB

6.2 ROM

The MEC1725 contains a 128KB block of ROM, located at address 00000000h in the ARM address space. The ROM contains boot code that is executed after the de-assertion of [RESET_SYS](#). The boot code loads an executable code image into SRAM. The ROM also includes a set of API functions that can be used for cryptographic functions, as well as loading SRAM with programs or data.

6.3 Additional Memory Regions

6.3.1 ALIAS RAM

The Alias RAM region, starting at address 20000000h, is an alias of the SRAM located at 118000h, and is the same size as that SRAM block. EC software can access memory in either the primary address or in the alias region; however, access is considerably slower to the alias region. The alias region exists in order to enable the ARM bit-band region located at address 20000000h.

6.3.2 RAM BIT-BAND REGION

The RAM bit-band region is an alias of the SRAM located at 2200_0000h, except that each bit is aliased to bit 0 of a 32-bit doubleword in the bit-band region. The upper 31 bits in each doubleword of the bit-band region are always 0. The bit-band region is therefore 32 times the size of the SRAM region. It can be used for atomic updates of individual bits of the SRAM, and is a feature of the ARM architecture.

The bit-band region can only be accessed by the ARM processor. Accesses by any other bus master will cause a memory fault.

6.3.3 CRYPTOGRAPHIC RAM

The cryptographic RAM is used by the cryptographic API functions in the ROM

6.3.4 REGISTER BIT-BAND REGION

The Register bit-band region is an 32-to-1 alias of the device register space starting at address 40000000h and ending with the Host register space at 400FFFFFF. Every bit in the register space is aliased to a byte in the Register bit-band region, and like the RAM bit-band region, can be used by EC software to read and write individual register bits. Only the EC Device Registers and the GPIO Registers can be accessed via the bit-band region.

A one bit write operation to a register bit in the bit-band region is implemented by the ARM processor by performing a read, a bit modification, followed by a write back to the same register. Software must be careful when using bit-banding if a register contains bits have side effects triggered by a read.

The bit-band region can only be accessed by the ARM processor. Accesses by any other bus master will cause a memory fault.

MEC1725

6.4 Memory Map

The memory map of the RAM and ROM is represented as follows:

FIGURE 6-1: MEMORY LAYOUT

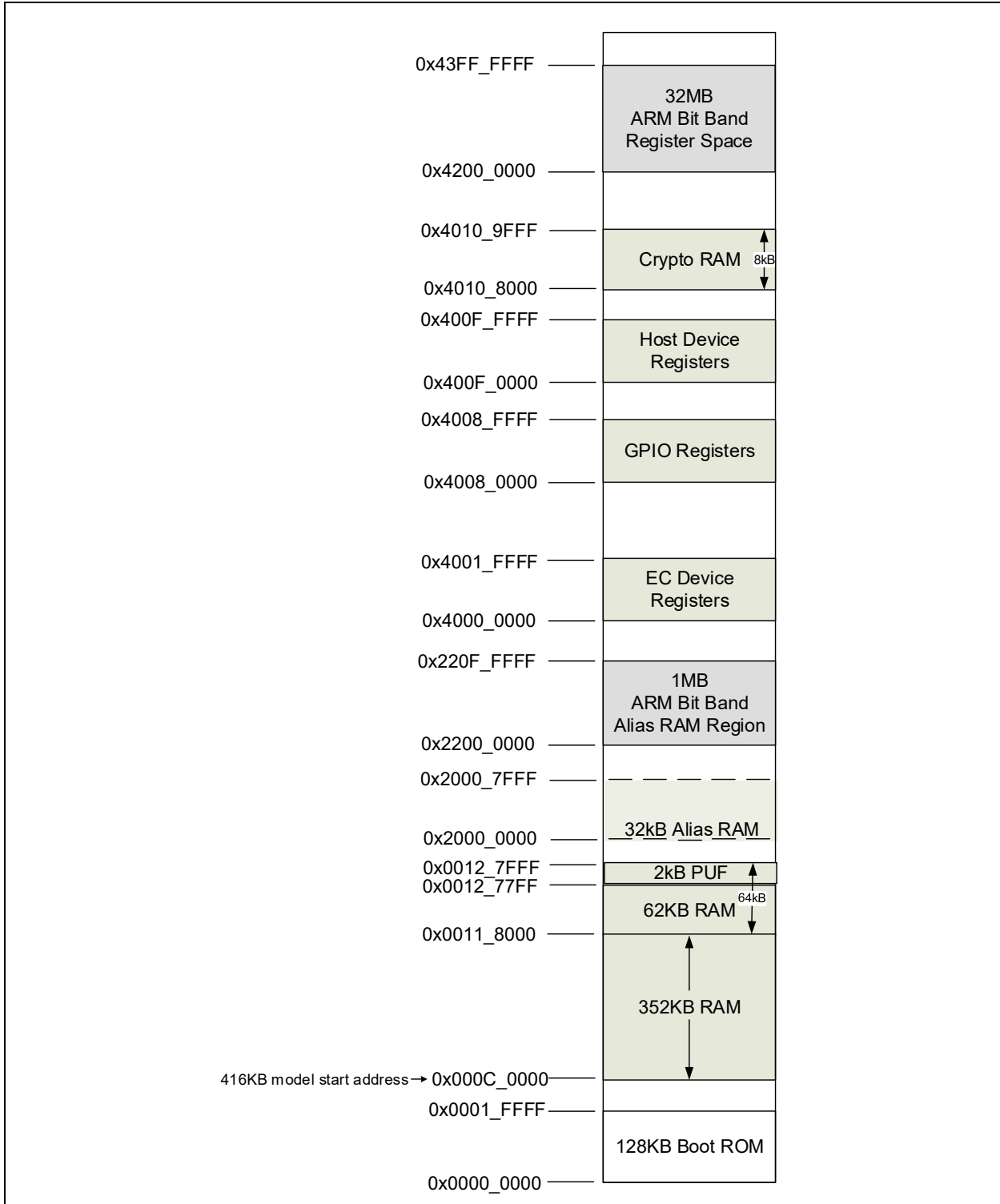

7.0 INTERNAL DMA CONTROLLER

7.1 Introduction

The [Internal DMA Controller](#) transfers data to/from the source from/to the destination. The firmware is responsible for setting up each channel. Afterwards either the firmware or the hardware may perform the flow control. The hardware flow control exists entirely inside the source device. Each transfer may be 1, 2, or 4 bytes in size, so long as the device supports a transfer of that size. Every device must be on the internal 32-bit address space.

7.2 References

No references have been cited for this chapter.

7.3 Terminology

TABLE 7-1: TERMINOLOGY

Term	Definition
DMA Transfer	This is a complete DMA Transfer which is done after the Master Device terminates the transfer, the Firmware Aborts the transfer or the DMA reaches its transfer limit. A DMA Transfer may consist of one or more data packets.
Data Packet	Each data packet may be composed of 1, 2, or 4 bytes. The size of the data packet is limited by the max size supported by both the source and the destination. Both source and destination will transfer the same number of bytes per packet.
Channel	The Channel is responsible for end-to-end (source-to-destination) Data Packet delivery.
Device	A Device may refer to a Master or Slave connected to the DMA Channel. Each DMA Channel may be assigned one or more devices.
Master Device	This is the master of the DMA, which determines when it is active. The Firmware is the master while operating in Firmware Flow Control. The Hardware is the master while operating in Hardware Flow Control. The Master Device in Hardware Mode is selected by DMA Channel Control:Hardware Flow Control Device . It is the index of the Flow Control Port .
Slave Device	The Slave Device is defined as the device associated with the targeted Memory Address.
Source	The DMA Controller moves data from the Source to the Destination. The Source provides the data. The Source may be either the Master or Slave Controller.
Destination	The DMA Controller moves data from the Source to the Destination. The Destination receives the data. The Destination may be either the Master or Slave Controller.

MEC1725

7.4 Interface

This block is designed to be accessed internally via a registered host interface.

FIGURE 7-1: INTERNAL DMA CONTROLLER I/O DIAGRAM

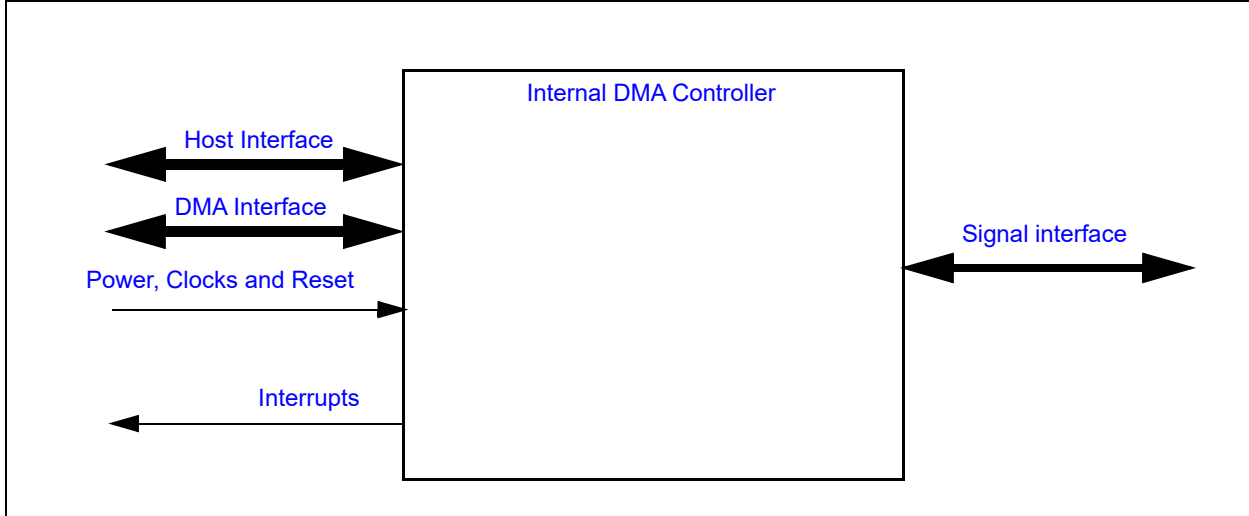

7.5 Signal interface

This block doesn't have any external signals that may be routed to the pin interface. This DMA Controller is intended to be used internally to transfer large amounts of data without the embedded controller being actively involved in the transfer.

7.6 Host Interface

The registers defined for the [Internal DMA Controller](#) are accessible by the various hosts as indicated in [Section 3.2, "Block Overview and Base Addresses"](#).

7.7 DMA Interface

Each DMA Master Device that may engage in a DMA transfer must have a compliant DMA interface. The following table lists the DMA Devices in the MEC1725.

TABLE 7-2: DMA CONTROLLER DEVICE SELECTION

Device Name	Device Number (Note 1)	Controller Source
SMB-I2C 0 Controller	0	Slave
	1	Master
SMB-I2C 1 Controller	2	Slave
	3	Master
SMB-I2C 2 Controller	4	Slave
	5	Master
SMB-I2C 3 Controller	6	Slave
	7	Master
SMB-I2C 4 Controller	8	Transmit
	9	Receive

Note 1: The Device Number is programmed into field [HARDWARE_FLOW_CONTROL_DEVICE](#) of the [DMA Channel N Control Register](#) register.

TABLE 7-2: DMA CONTROLLER DEVICE SELECTION

Device Name	Device Number (Note 1)	Controller Source
QMSPI Controller	10	Transmit
	11	Receive
GP-SPI0 Controller	12	Transmit
	13	Receive
GP-SPI1 Controller	14	Transmit
	15	Receive

Note 1: The Device Number is programmed into field `HARDWARE_FLOW_CONTROL_DEVICE` of the `DMA Channel N Control Register` register.

TABLE 7-3: DMA CONTROLLER MASTER DEVICES SIGNAL LIST

Device Name	Dev Num	Device Signal Name	Direction	Description
SMB-I2C 0 Controller	0	SMB-I2C_SD-MA_Req	INPUT	DMA request control from SMB-I2C Slave channel.
		SMB-I2C_SD-MA_Term	INPUT	DMA termination control from SMB-I2C Slave channel.
		SMB-I2C_SDMA_-Done	OUTPUT	DMA termination control from DMA Controller to Slave channel.
	1	SMB-I2C_MD-MA_Req	INPUT	DMA request control from SMB-I2C Master channel.
		SMB-I2C_MD-MA_Term	INPUT	DMA termination control from SMB-I2C Master channel.
		SMB-I2C_MDMA_-Done	OUTPUT	DMA termination control from DMA Controller to Master channel.
SMB-I2C 1 Controller	2	SMB-I2C_SD-MA_Req	INPUT	DMA request control from SMB-I2C Slave channel.
		SMB-I2C_SD-MA_Term	INPUT	DMA termination control from SMB-I2C Slave channel.
		SMB-I2C_SDMA_-Done	OUTPUT	DMA termination control from DMA Controller to Slave channel.
	3	SMB-I2C_MD-MA_Req	INPUT	DMA request control from SMB-I2C Master channel.
		SMB-I2C_MD-MA_Term	INPUT	DMA termination control from SMB-I2C Master channel.
		SMB-I2C_MDMA_-Done	OUTPUT	DMA termination control from DMA Controller to Master channel.

TABLE 7-3: DMA CONTROLLER MASTER DEVICES SIGNAL LIST (CONTINUED)

Device Name	Dev Num	Device Signal Name	Direction	Description
SMB-I2C 2 Controller	4	SMB-I2C_SD-MA_Req	INPUT	DMA request control from SMB-I2C Slave channel.
		SMB-I2C_SD-MA_Term	INPUT	DMA termination control from SMB-I2C Slave channel.
		SMB-I2C_SDMA_-Done	OUTPUT	DMA termination control from DMA Controller to Slave channel.
	5	SMB-I2C_MD-MA_Req	INPUT	DMA request control from SMB-I2C Master channel.
		SMB-I2C_MD-MA_Term	INPUT	DMA termination control from SMB-I2C Master channel.
		SMB-I2C_MDMA_-Done	OUTPUT	DMA termination control from DMA Controller to Master channel.
SMB-I2C 3 Controller	6	SMB-I2C_SD-MA_Req	INPUT	DMA request control from SMB-I2C Slave channel.
		SMB-I2C_SD-MA_Term	INPUT	DMA termination control from SMB-I2C Slave channel.
		SMB-I2C_SDMA_-Done	OUTPUT	DMA termination control from DMA Controller to Slave channel.
	7	SMB-I2C_MD-MA_Req	INPUT	DMA request control from SMB-I2C Master channel.
		SMB-I2C_MD-MA_Term	INPUT	DMA termination control from SMB-I2C Master channel.
		SMB-I2C_MDMA_-Done	OUTPUT	DMA termination control from DMA Controller to Master channel.
SMB-I2C 4 Controller	8	SMB-I2C_SD-MA_Req	INPUT	DMA request control from SMB-I2C Slave channel.
		SMB-I2C_SD-MA_Term	INPUT	DMA termination control from SMB-I2C Slave channel.
		SMB-I2C_SDMA_-Done	OUTPUT	DMA termination control from DMA Controller to Slave channel.
	9	SMB-I2C_MD-MA_Req	INPUT	DMA request control from SMB-I2C Master channel.
		SMB-I2C_MD-MA_Term	INPUT	DMA termination control from SMB-I2C Master channel.
		SMB-I2C_MDMA_-Done	OUTPUT	DMA termination control from DMA Controller to Master channel.
Quad SPI Controller	10	QSPI_TDMA_Req	INPUT	DMA request control from Quad SPI TX channel.
		QSPI_TDMA_Term	INPUT	DMA termination control from Quad SPI TX channel.
		QMSPi_TDMA_-Done	OUTPUT	DMA termination control from DMA Controller to Quad SPI TDMA Channel.
	11	QSPI_RDMA_Req	INPUT	DMA request control from Quad SPI RX channel.
		QSPI_RDMA_Term	INPUT	DMA termination control from Quad SPI RX channel.
		QMSPi_RDMA_-Done	OUTPUT	DMA termination control from DMA Controller to Quad SPI RDMA Channel.

TABLE 7-3: DMA CONTROLLER MASTER DEVICES SIGNAL LIST (CONTINUED)

Device Name	Dev Num	Device Signal Name	Direction	Description
GP-SPI0 Controller	12	SPI_TDMA_Req	INPUT	DMA request control from Quad SPI TX channel.
	13	SPI_RDMA_Req	INPUT	DMA request control from Quad SPI RX channel.
GP-SPI1 Controller	14	SPI_TDMA_Req	INPUT	DMA request control from Quad SPI TX channel.
	15	SPI_RDMA_Req	INPUT	DMA request control from Quad SPI RX channel.

7.8 Power, Clocks and Reset

This section defines the Power, Clock, and Reset parameters of the block.

7.8.1 POWER DOMAINS

TABLE 7-4: POWER SOURCES

Name	Description
VTR_CORE	This power well sources the registers and logic in this block.

7.8.2 CLOCK INPUTS

TABLE 7-5: CLOCK INPUTS

Name	Description
96 MHz	This clock signal drives selected logic (e.g., counters).

7.8.3 RESETS

TABLE 7-6: RESET SIGNALS

Name	Description
RESET_SYS	This reset signal resets all of the registers and logic in this block.
RESET	This reset is generated if either the RESET_SYS is asserted or the SOFT_RESET bit is asserted.

7.9 Interrupts

This section defines the Interrupt Sources generated from this block.

TABLE 7-7: INTERRUPTS

Source	Description
DMAx	Direct Memory Access Channel x This signal is generated by the STATUS_DONE bit.

7.10 Low Power Modes

The [Internal DMA Controller](#) may be put into a low power state by the chip's Power, Clocks, and Reset (PCR) circuitry.

When the block is commanded to go to sleep it will place the DMA block into sleep mode only after all transactions on the DMA have been completed. For Firmware Flow Controlled transactions, the DMA will wait until it hits its terminal count and clears the Go control bit. For Hardware Flow Control, the DMA will go to sleep after either the terminal count is hit, or the Master device flags the terminate signal.

7.11 Description

The MEC1725 features a 16 channel DMA controller. The DMA controller can autonomously move data from/to any DMA capable master device to/from any populated memory location. This mechanism allows hardware IP blocks to transfer large amounts of data into or out of memory without EC intervention.

The DMA has the following characteristics:

- Data is only moved 1 [Data Packet](#) at a time
- Data only moves between devices that are accessible via the internal 32-bit address space
- The DMA Controller has 16 DMA Channels
- Each DMA Channel may be configured to communicate with any DMA capable device on the 32-bit internal address space. Each device has been assigned a device number. See [Section 7.7, "DMA Interface"](#).

The controller will access SRAM buffers only with incrementing addresses (that is, it cannot start at the top of a buffer, nor does it handle circular buffers automatically). The controller does not handle chaining (that is, automatically starting a new DMA transfer when one finishes).

7.11.1 CONFIGURATION

The DMA Controller is enabled via the [ACTIVATE](#) bit in [DMA Main Control Register](#) register.

Each DMA Channel must also be individually enabled via the [CHANNEL_ACTIVATE](#) bit in the [DMA Channel N Activate Register](#) to be operational.

Before starting a DMA transaction on a DMA Channel the host must assign a DMA Master to the channel via [HARDWARE_FLOW_CONTROL_DEVICE](#). The host must not configure two different channels to the same DMA Master at the same time.

Data will be transferred between the DMA Master, starting at the programmed [DEVICE_ADDRESS](#), and the targeted memory location, starting at the [MEMORY_START_ADDRESS](#). The address for either the DMA Master or the targeted memory location may remain static or it may increment. To enable the DMA Master to increment its address set the [INCREMENT_DEVICE_ADDRESS](#) bit. To enable the targeted memory location to increment its addresses set the [INCREMENT_MEMORY_ADDRESS](#). The DMA transfer will continue as long as the target memory address being accessed is less than the [MEMORY_END_ADDRESS](#). If the DMA Controller detects that the memory location it is attempting to access on the Target is equal to the [MEMORY_END_ADDRESS](#) it will notify the DMA Master that the transaction is done. Otherwise the Data will be transferred in packets. The size of the packet is determined by the [TRANSFER_SIZE](#).

7.11.2 OPERATION

The DMA Controller is designed to move data from one memory location to another.

7.11.2.1 Establishing a Connection

A DMA Master will initiate a DMA Transaction by requesting access to a channel. The DMA arbiter, which evaluates each channel request using a basic round robin algorithm, will grant access to the DMA master. Once granted, the channel will hold the grant until it decides to release it, by notifying the DMA Controller that it is done.

If Firmware wants to prevent any other channels from being granted while it is active it can set the [LOCK_CHANNEL](#) bit.

7.11.2.2 Initiating a Transfer

Once a connection is established the DMA Master will issue a DMA request to start a DMA transfer. If Firmware wants to have a transfer request serviced it must set the [RUN](#) bit to have its transfer requests serviced.

Firmware can initiate a transaction by setting the [TRANSFER_GO](#) bit. The DMA transfer will remain active until either the Master issues a Terminate or the DMA Controller signals that the transfer is [DONE](#). Firmware may terminate a transaction by setting the [TRANSFER_ABORT](#) bit.

Note: Before initiating a DMA transaction via firmware the hardware flow control must be disabled via the DISABLE_HARDWARE_FLOW_CONTROL bit.

Data may be moved from the DMA Master to the targeted Memory address or from the targeted Memory Address to the DMA Master. The direction of the transfer is determined by the [TRANSFER_DIRECTION](#) bit.

Once a transaction has been initiated firmware can use the [STATUS_DONE](#) bit to determine when the transaction is completed. This status bit is routed to the interrupt interface. In the same register there are additional status bits that indicate if the transaction completed successfully or with errors. These bits are OR'd together with the [STATUS_DONE](#) bit to generate the interrupt event. Each status bit may be individually enabled/disabled from generating this event.

7.11.2.3 Reusing a DMA Channel

After a DMA Channel controller has completed, firmware **must** clear both the [DMA Channel N Control Register](#) and the [DMA Channel N Interrupt Status Register](#). After both have been cleared to 0, the Channel Control Register can then be configured for the next transaction.

7.11.2.4 CRC Generation

A CRC generator can be attached to a DMA channel in order to generate a CRC on the data as it is transferred from the source to the destination. The CRC used is the CRC-32 algorithm used in IEEE 802.3 and many other protocols, using the polynomial $x^{32} + x^{26} + x^{23} + x^{22} + x^{16} + x^{12} + x^{11} + x^{10} + x^8 + x^7 + x^5 + x^4 + x^2 + x + 1$. The CRC generation takes place in parallel with the data transfer; enabling CRC will not increase the time to complete a DMA transaction. The CRC generator has the optional ability to automatically transfer the generated CRC to the destination after the data transfer has completed.

CRC generation is subject to a number of restrictions:

- The CRC is only generated on channels that have the CRC hardware. See [Table 7-10, "Channel Register Summary"](#) for a definition of which channels have the ability to generate a CRC
- The DMA transfer must be 32-bits
- If CRC is enabled, DMA interrupts are inhibited until the CRC is completed, including the optional post-transfer copy of it is enabled
- The CRC must be initialized by firmware. The value FFFFFFFFh must be written to the Data Register in order to initialize the generator for the standard CRC-32-IEEE algorithm
- The CRC will be bit-order reversed and inverted as required by the CRC algorithm

7.11.2.5 Block Fill Option

A Fill engine can be attached to a DMA channel in order to provide a fast mechanism to set a block of memory to a fixed value (for example, clearing a block of memory to zero). The block fill operation runs approximately twice as fast as a memory-to-memory copy.

In order to fill memory with a constant value, firmware **must** configure the channel in the following order:

1. Set the [DMA Channel N Fill Data Register](#) to the desired fill value
2. Set the [DMA Channel N Fill Enable Register](#) to '1b', enabling the Fill engine
3. Set the [DMA Channel N Control Register](#) to the following values:
 - [RUN](#) = 0
 - [TRANSFER_DIRECTION](#) = 0 (memory destination)
 - [INCREMENT_MEMORY_ADDRESS](#) = 1 (increment memory address after each transfer)
 - [INCREMENT_DEVICE_ADDRESS](#) = 1
 - [DISABLE_HARDWARE_FLOW_CONTROL](#) = 1 (no hardware flow control)
 - [TRANSFER_SIZE](#) = 1, 2 or 4 (as required)
 - [TRANSFER_ABORT](#) = 0
 - [TRANSFER_GO](#) = 1 (this starts the transfer)

7.12 EC Registers

The DMA Controller consists of a Main Block and a number of Channels. [Table 7-9, "Main Register Summary"](#) lists the registers in the Main Block and [Table 7-10, "Channel Register Summary"](#) lists the registers in each channel. Addresses for each register are determined by adding the offset to the Base Address for the DMA Controller Block in the Block Overview and Base Address Table in [Section 3.0, "Device Inventory"](#).

Registers are listed separately for the Main Block of the DMA Controller and for a DMA Channel. Each Channel has the same set of registers. The absolute register address for registers in each channel are defined by adding the Base Address for the DMA Controller Block, the Offset for the Channel shown in [Table 7-8, "DMA Channel Offsets"](#) to the offsets listed in [Table 7-9, "Main Register Summary"](#) or [Table 7-10, "Channel Register Summary"](#).

MEC1725

TABLE 7-8: DMA CHANNEL OFFSETS

Instance Name	Channel Number	Offset
DMA Controller	Main Block	000h
DMA Controller	0	040h
DMA Controller	1	080h
DMA Controller	2	0C0h
DMA Controller	3	100h
DMA Controller	4	140h
DMA Controller	5	180h
DMA Controller	6	1C0h
DMA Controller	7	200h
DMA Controller	8	240h
DMA Controller	9	280h
DMA Controller	10	2C0h
DMA Controller	11	300h
DMA Controller	12	340h
DMA Controller	13	380h
DMA Controller	14	3C0h
DMA Controller	15	400h

TABLE 7-9: MAIN REGISTER SUMMARY

Offset	Register Name
00h	DMA Main Control Register
04h	DMA Data Packet Register

7.12.1 DMA MAIN CONTROL REGISTER

Offset	00h			
Bits	Description	Type	Default	Reset Event
7:2	Reserved	RES	-	-
1	SOFT_RESET Soft reset the entire module. This bit is self-clearing.	W	0b	-
0	ACTIVATE Enable the blocks operation. 1=Enable block. Each individual channel must be enabled separately. 0=Disable all channels.	R/WS	0b	RESET

7.12.2 DMA DATA PACKET REGISTER

Offset	04h			
Bits	Description	Type	Default	Reset Event
31:0	DATA_PACKET Debug register that has the data that is stored in the Data Packet. This data is read data from the currently active transfer source.	R	0000h	-

TABLE 7-10: CHANNEL REGISTER SUMMARY

Offset	Register Name (Note 1)
00h	DMA Channel N Activate Register
04h	DMA Channel N Memory Start Address Register
08h	DMA Channel N Memory End Address Register
0Ch	DMA Channel N Device Address
10h	DMA Channel N Control Register
14h	DMA Channel N Interrupt Status Register
18h	DMA Channel N Interrupt Enable Register
1Ch	TEST
20h (Note 2)	DMA Channel N CRC Enable Register
24h (Note 2)	DMA Channel N CRC Data Register
28h (Note 2)	DMA Channel N CRC Post Status Register
2Ch (Note 2)	TEST
20h (Note 3)	DMA Channel N Fill Enable Register
24h (Note 3)	DMA Channel N Fill Data Register
28h (Note 3)	DMA Channel N Fill Status Register
2Ch (Note 3)	TEST
<p>Note 1: The letter 'N' following DMA Channel indicates the Channel Number. Each Channel implemented will have these registers to determine that channel's operation.</p> <p>2: These registers are only present on DMA Channel 0. They are reserved on all other channels.</p> <p>3: These registers are only present on DMA Channel 1. They are reserved on all other channels.</p>	

7.12.3 DMA CHANNEL N ACTIVATE REGISTER

Offset	00h			
Bits	Description	Type	Default	Reset Event
7:1	Reserved	RES	-	-
0	CHANNEL_ACTIVATE Enable this channel for operation. The DMA Main Control:Activate must also be enabled for this channel to be operational.	R/W	0h	RESET

MEC1725

7.12.4 DMA CHANNEL N MEMORY START ADDRESS REGISTER

Offset	04h			
Bits	Description	Type	Default	Reset Event
31:0	<p>MEMORY_START_ADDRESS</p> <p>This is the starting address for the Memory device.</p> <p>This field is updated by Hardware after every packet transfer by the size of the transfer, as defined by DMA Channel Control:Channel Transfer Size while the DMA Channel Control:Increment Memory Address is Enabled.</p> <p>The Memory device is defined as the device that is the slave device in the transfer. With Hardware Flow Control, the Memory device is the device that is not connected to the Hardware Flow Controlling device.</p>	R/W	0000h	RESET

7.12.5 DMA CHANNEL N MEMORY END ADDRESS REGISTER

Offset	08h			
Bits	Description	Type	Default	Reset Event
31:0	<p>MEMORY_END_ADDRESS</p> <p>This is the ending address for the Memory device.</p> <p>This will define the limit of the transfer, so long as DMA Channel Control:Increment Memory Address is Enabled. When the Memory Start Address is equal to this value, the DMA will terminate the transfer and flag the status DMA Channel Interrupt:Status Done.</p> <p>Note: If the TRANSFER_SIZE field in the DMA Channel N Control Register is set to 2 (for 2-byte transfers, this address must be evenly divisible by 2 or the transfer will not terminate properly. If the TRANSFER_SIZE field is set to 4 (for 4-byte transfers, this address must be evenly divisible by 4 or the transfer will not terminate properly.</p>	R/W	0000h	RESET

7.12.6 DMA CHANNEL N DEVICE ADDRESS

Offset	0Ch			
Bits	Description	Type	Default	Reset Event
31:0	<p>DEVICE_ADDRESS</p> <p>This is the Master Device address.</p> <p>This is used as the address that will access the Device on the DMA. The Device is defined as the Master of the DMA transfer; as in the device that is controlling the Hardware Flow Control.</p> <p>This field is updated by Hardware after every Data Packet transfer by the size of the transfer, as defined by DMA Channel Control:Transfer Size while the DMA Channel Control:Increment Device Address is Enabled.</p>	R/W	0000h	RESET

7.12.7 DMA CHANNEL N CONTROL REGISTER

Offset	10h			
Bits	Description	Type	Default	Reset Event
31:26	Reserved	RES	-	-
25	TRANSFER_ABORT This is used to abort the current transfer on this DMA Channel. The aborted transfer will be forced to terminate immediately.	R/W	0h	RESET
24	TRANSFER_GO This is used for the Firmware Flow Control DMA transfer. This is used to start a transfer under the Firmware Flow Control . Do not use this in conjunction with the Hardware Flow Control ; DISABLE_HARDWARE_FLOW_CONTROL must be set in order for this field to function correctly.	R/W	0h	RESET
23	Reserved	RES	-	-
22:20	TRANSFER_SIZE This is the transfer size in Bytes of each Data Packet transfer. The transfer size must be a legal transfer size. Valid sizes are 1, 2 and 4 Bytes.	R/W	0h	RESET
19	DISABLE_HARDWARE_FLOW_CONTROL Setting this bit to '1'b will Disable Hardware Flow Control . When disabled, any DMA Master device attempting to communicate to the DMA over the DMA Flow Control Interface will be ignored. This should be set before using the DMA channel in Firmware Flow Control mode.	R/W	0h	RESET
18	LOCK_CHANNEL This is used to lock the arbitration of the Channel Arbiter on this channel once this channel is granted. Once this is locked, it will remain on the arbiter until it has completed its transfer (either the Transfer Aborted, Transfer Done or Transfer Terminated conditions). Note: This setting may starve other channels if the locked channel takes an excessive period of time to complete.	R/W	0h	RESET
17	INCREMENT_DEVICE_ADDRESS If this bit is '1'b, the DEVICE_ADDRESS will be incremented by TRANSFER_SIZE after every Data Packet transfer	R/W	0h	RESET
16	INCREMENT_MEMORY_ADDRESS If this bit is '1'b, the MEMORY_START_ADDRESS will be incremented by TRANSFER_SIZE after every Data Packet transfer Note: If this is not set, the DMA will never terminate the transfer on its own. It will have to be terminated through the Hardware Flow Control or through a DMA Channel Control:Transfer Abort.	R/W	0h	RESET

MEC1725

Offset	10h	Bits	Description	Type	Default	Reset Event
15:9	HARDWARE_FLOW_CONTROL_DEVICE This is the device that is connected to this channel as its Hardware Flow Control master. The Flow Control Interface is a bus with each master concatenated onto it. This selects which bus index of the concatenated Flow Control Interface bus is targeted towards this channel.	R/W	0h	RESET		
8	TRANSFER_DIRECTION This determines the direction of the DMA Transfer. 1=Data Packet Read from MEMORY_START_ADDRESS followed by Data Packet Write to DEVICE_ADDRESS 0=Data Packet Read from DEVICE_ADDRESS followed by Data Packet Write to MEMORY_START_ADDRESS	R/W	0h	RESET		
7:6	Reserved	RES	-	-		
5	BUSY This is a status signal. 1=The DMA Channel is busy (FSM is not IDLE) 0=The DMA Channel is not busy (FSM is IDLE)	R	0h	RESET		
4:3	TEST	R	0h	RESET		
2	DONE This is a status signal. It is only valid while RUN is Enabled. This is the inverse of the DMA Channel Control:Busy field, except this is qualified with the DMA Channel Control:Run field. 1=Channel is done 0=Channel is not done or it is OFF	R	0h	RESET		
1	REQUEST This is a status field. 1=There is a transfer request from the Master Device 0=There is no transfer request from the Master Device	R	0h	RESET		
0	RUN This is a control field. It only applies to Hardware Flow Control mode. 1=This channel is enabled and will service transfer requests 0=This channel is disabled. All transfer requests are ignored	R/W	0h	RESET		

7.12.8 DMA CHANNEL N INTERRUPT STATUS REGISTER

Offset	14h			
Bits	Description	Type	Default	Reset Event
7:3	Reserved	RES	-	-
2	<p>STATUS_DONE</p> <p>This is an interrupt source register. This flags when the DMA Channel has completed a transfer successfully on its side. A completed transfer is defined as when the DMA Channel reaches its limit; Memory Start Address equals Memory End Address. A completion due to a Hardware Flow Control Terminate will not flag this interrupt.</p> <p>1=MEMORY_START_ADDRESS equals MEMORY_END_ADDRESS 0=MEMORY_START_ADDRESS does not equal MEMORY_END_ADDRESS</p>	R/WC	0h	RESET
1	<p>STATUS_ENABLE_FLOW_CONTROL</p> <p>This is an interrupt source register. This flags when the DMA Channel has encountered a Hardware Flow Control Request after the DMA Channel has completed the transfer. This means the Master Device is attempting to overflow the DMA.</p> <p>1=Hardware Flow Control is requesting after the transfer has completed 0=No Hardware Flow Control event</p>	R/WC	0h	RESET
0	<p>STATUS_BUS_ERROR</p> <p>This is an interrupt source register. This flags when there is an Error detected over the internal 32-bit Bus.</p> <p>1=Error detected.</p>	R/WC	0h	RESET

7.12.9 DMA CHANNEL N INTERRUPT ENABLE REGISTER

Offset	18h			
Bits	Description	Type	Default	Reset Event
7:3	Reserved	RES	-	-
2	<p>STATUS_ENABLE_DONE</p> <p>This is an interrupt enable for STATUS_DONE.</p> <p>1=Enable Interrupt 0=Disable Interrupt</p>	R/W	0h	RESET
1	<p>STATUS_ENABLE_FLOW_CONTROL_ERROR</p> <p>This is an interrupt enable for STATUS_ENABLE_FLOW_CONTROL.</p> <p>1=Enable Interrupt 0=Disable Interrupt</p>	R/W	0h	RESET

MEC1725

Offset	18h			
Bits	Description	Type	Default	Reset Event
0	STATUS_ENABLE_BUS_ERROR This is an interrupt enable for STATUS_BUS_ERROR . 1=Enable Interrupt 0=Disable Interrupt	R/W	0h	RESET

7.12.10 DMA CHANNEL N CRC ENABLE REGISTER

Offset	20h			
Bits	Description	Type	Default	Reset Event
31:2	Reserved	RES	-	-
1	CRC_POST_TRANSFER_ENABLE The bit enables the transfer of the calculated CRC-32 after the completion of the DMA transaction. If the DMA transaction is aborted by either firmware or an internal bus error, the transfer will not occur. If the target of the DMA transfer is a device and the device signaled the termination of the DMA transaction, the CRC post transfer will not occur. 1=Enable the transfer of CRC-32 for DMA Channel N after the DMA transaction completes 0=Disable the automatic transfer of the CRC	R/W	0h	RESET
0	CRC_MODE_ENABLE 1=Enable the calculation of CRC-32 for DMA Channel N 0=Disable the calculation of CRC-32 for DMA Channel N	R/W	0h	RESET

7.12.11 DMA CHANNEL N CRC DATA REGISTER

Offset	24h			
Bits	Description	Type	Default	Reset Event
31:0	<p>CRC</p> <p>Writes to this register initialize the CRC generator. Reads from this register return the output of the CRC that is calculated from the data transferred by DMA Channel N. The output of the CRC generator is bit-reversed and inverted on reads, as required by the CRC-32-IEEE definition.</p> <p>A CRC can be accumulated across multiple DMA transactions on Channel N. If it is necessary to save the intermediate CRC value, the result of the read of this register must be bit-reversed and inverted before being written back to this register.</p>	R/W	0h	RESET

7.12.12 DMA CHANNEL N CRC POST STATUS REGISTER

Offset	28h			
Bits	Description	Type	Default	Reset Event
31:4	Reserved	RES	-	-
3	<p>CRC_DATA_READY</p> <p>This bit is set to '1b' when the DMA controller is processing the post-transfer of the CRC data. This bit is cleared to '0b' when the post-transfer completes.</p>	R	0h	RESET
2	<p>CRC_DATA_DONE</p> <p>This bit is set to '1b' when the DMA controller has completed the post-transfer of the CRC data. This bit is cleared to '0b' when the a new DMA transfer starts.</p>	R	0h	RESET
1	<p>CRC_RUNNING</p> <p>This bit is set to '1b' when the DMA controller starts the post-transfer transmission of the CRC. It is only set when the post-transfer is enabled by the CRC_POST_TRANSFER_ENABLE field. This bit is cleared to '0b' when the post-transfer completes.</p>	R	0h	RESET
0	<p>CRC_DONE</p> <p>This bit is set to '1b' when the CRC calculation has completed from either normal or forced termination. It is cleared to '0b' when the DMA controller starts a new transfer on the channel.</p>	R	0h	RESET

MEC1725

7.12.13 DMA CHANNEL N FILL ENABLE REGISTER

Offset	20h			
Bits	Description	Type	Default	Reset Event
31:1	Reserved	RES	-	-
0	FILL_MODE_ENABLE 1=Enable the Fill Engine for DMA Channel N 0=Disable the Fill Engine for DMA Channel N	R/W	0h	RESET

7.12.14 DMA CHANNEL N FILL DATA REGISTER

Offset	24h			
Bits	Description	Type	Default	Reset Event
31:0	DATA This is the data pattern used to fill memory.	R/W	0h	RESET

7.12.15 DMA CHANNEL N FILL STATUS REGISTER

Offset	28h			
Bits	Description	Type	Default	Reset Event
31:2	Reserved	RES	-	-
1	FILL_RUNNING This bit is '1b' when the Fill operation starts and is cleared to '0b' when the Fill operation completes.	R	0h	RESET
0	FILL_DONE This bit is set to '1b' when the Fill operation has completed from either normal or forced termination. It is cleared to '0b' when the DMA controller starts a new transfer on the channel.	R	0h	RESET

8.0 EC INTERRUPT AGGREGATOR

8.1 Introduction

The [EC Interrupt Aggregator](#) works in conjunction with the processor's interrupt interface to handle hardware interrupts and exceptions.

Exceptions are synchronous to instructions, are not maskable, and have higher priority than interrupts. All three exceptions - reset, memory error, and instruction error - are hardwired directly to the processor. Interrupts are typically asynchronous and are maskable.

Interrupts classified as wake events can be recognized without a running clock, e.g., while the MEC1725 is in sleep state.

This chapter focuses on the [EC Interrupt Aggregator](#). Please refer to embedded controller's documentation for more information on interrupt and exception handling.

8.2 Interface

This block is designed to be accessed internally via a registered host interface. The following diagram illustrates the various interfaces to the block.

FIGURE 8-1: EC INTERRUPT AGGREGATOR INTERFACE DIAGRAM

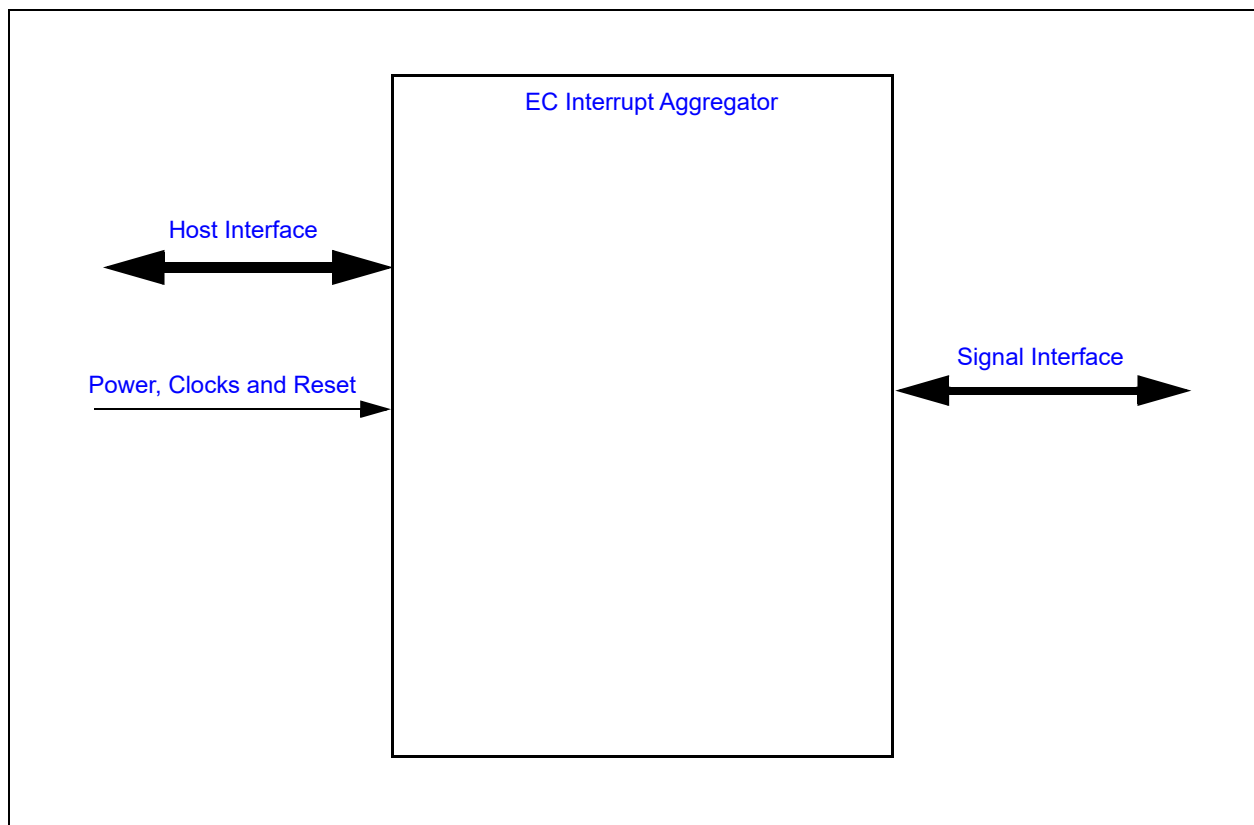

8.3 Signal Description

8.3.1 SIGNAL INTERFACE

There are no external signals for this block.

MEC1725

8.4 Host Interface

The registers defined for the [EC Interrupt Aggregator](#) are only accessible by the various hosts as indicated in [Section 3.2, "Block Overview and Base Addresses"](#).

8.5 Power, Clocks and Reset

8.5.1 BLOCK POWER DOMAIN

TABLE 8-1: BLOCK POWER

Power Well Source	Effect on Block
VTR_CORE	The EC Interrupt Aggregator block and registers operate on this single power well.

8.5.2 BLOCK CLOCKS

TABLE 8-2: CLOCK INPUTS

Name	Description
48MHz	This clock signal drives selected logic (e.g., counters).

8.5.3 BLOCK RESET

TABLE 8-3: BLOCK RESETS

Reset Name	Reset Description
RESET_SYS	This signal is used to indicate when the VTR_CORE logic and registers in this block are reset.

8.6 Interrupts

This block aggregates all the interrupts targeted for the embedded controller into the Source Registers defined in [Section 8.9, "EC Registers"](#). The unmasked bits of each source register are then OR'd together and routed to the embedded controller's interrupt interface. The name of each Source Register identifies the IRQ number of the interrupt port on the embedded controller.

8.7 Low Power Modes

This block always automatically adjusts to operate in the lowest power mode by gating its clock when not required.

8.8 Description

The interrupt generation logic is made of groups of signals, each of which consist of a Status register, a Enable Set register, and Enable Clear register and a Result register.

The Status and Enable are latched registers. There is one set of Enable register bits; both the Enable Set and Enable Clear registers return the same result when read. The Enable Set interface is used to set individual bits in the Enable register, and the Enable Clear is used to clear individual bits. The Result register is a bit by bit AND function of the Source and Enable registers. All the bits of the Result register are OR'ed together and AND'ed with the corresponding bit in the Block Select register to form the interrupt signal that is routed to the ARM interrupt controller.

The Result register bits may also be enabled to the NVIC block via the [NVIC_EN](#) bit in the [Interrupt Control Register](#) register. See [Chapter 47.0, "EC Subsystem Registers"](#)

[Section 8.8.1](#) shows a representation of the interrupt structure.

FIGURE 8-2: INTERRUPT STRUCTURE

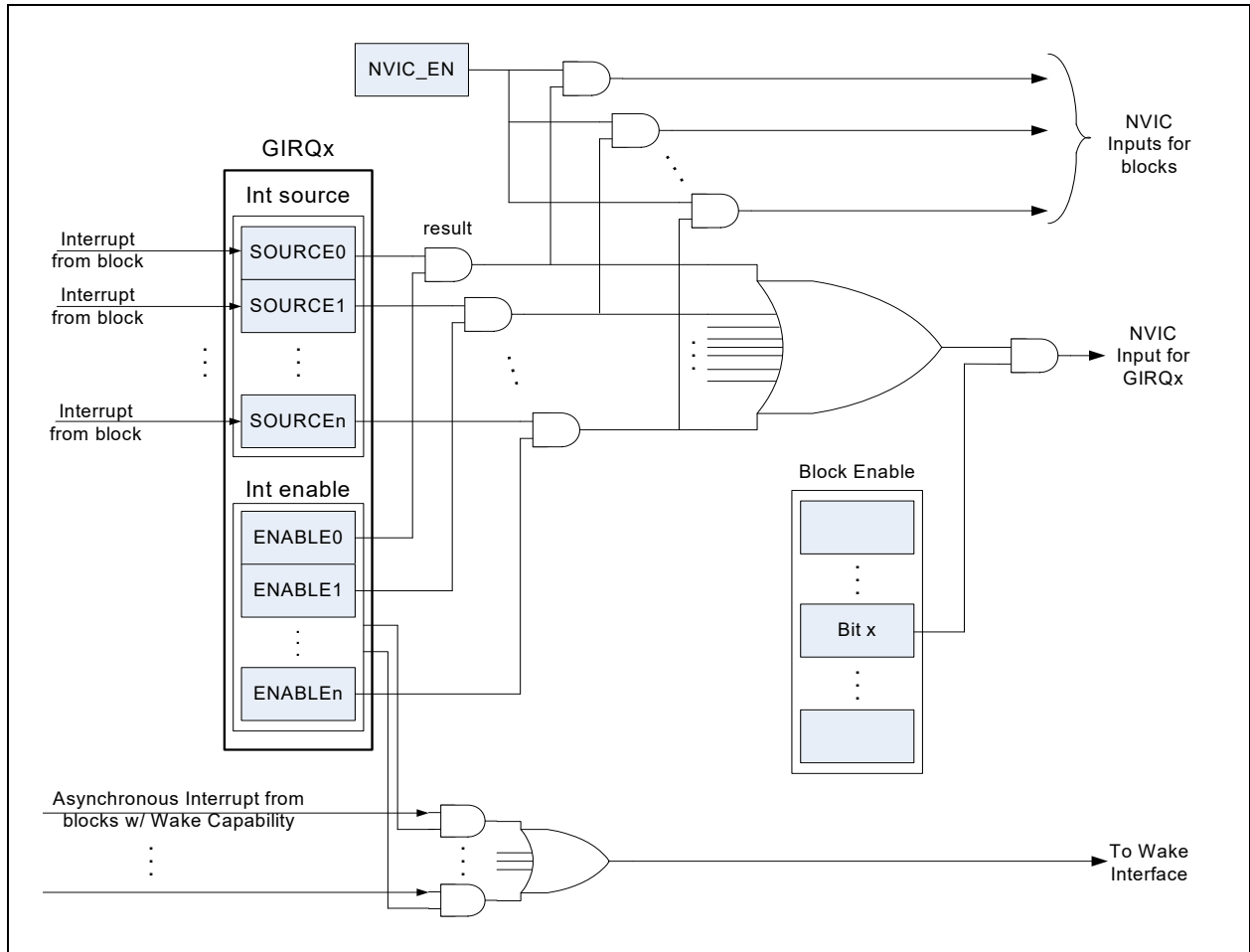

8.8.1 AGGREGATED INTERRUPTS

All interrupts are routed to the ARM processor through the ARM Nested Vectored Interrupt Controller (NVIC). As shown in [Figure 8-2, "Interrupt Structure"](#), all interrupt sources are aggregated into the GIRQx Source registers. In many cases, the Result bit for an individual interrupt source is tied directly to the NVIC. These interrupts are shown in the “Direct NVIC” column in the Interrupt Bit Assignments table. In addition, all GIRQx can also generate an interrupt to the NVIC when any of the enabled interrupts in its group is asserted. The NVIC vectors for the aggregated GIRQ interrupts are shown in the “Agg NVIC” column.

Firmware should not enable the group GIRQ NVIC interrupt at the same time individual direct interrupts for members of the group are enabled. If both are enabled, the processor will receive two interrupts for an event, one from the GIRQ and one from the direct interrupt.

Note: The four Soft Interrupts that are defined by the RTOS Timer do not have individual NVIC vectors. If the use of the SWI interrupts is required, then all interrupts in the GIRQ must disable the individual NVIC vectors.

Note: These four Soft Interrupts are only available in aggregate mode

MEC1725

8.8.2 WAKE GENERATION

Wake-capable interrupts are listed in [Table 3-3, "GPIO Mapping"](#) with a designation of 'Yes' in the Wake Event column. All interrupts, except GIRQ22, generate an EC Interrupt event. They are routed to source bits that are synchronized to the [60 MHz Ring Oscillator](#). If enabled, the Interrupt Result is fed into the Priority Encoder/Decision Logic, which generates the interrupt vector to the [NVIC Interrupt Interface](#).

Some Interrupts, which are labeled Wake-Capable, are also routed as Wake Events to the Chip's Wake Logic. These are asynchronous events that are used to resume the [60 MHz Ring Oscillator](#) operation from a sleep state and wake the processor.

8.8.2.1 Wake Capable Interrupts

All GPIO inputs are wake-capable. In order for a GPIO input to wake the MEC1725 from a sleep state, the Interrupt Detection field of the GPIO Pin Control Register must be set to Rising Edge Triggered, Falling Edge Triggered, or Either Edge Triggered. If the Interrupt Detection field is set to any other value, a GPIO input will not trigger a wake interrupt.

Some of the Wake Capable Interrupts are triggered by activity on pins that are shared with a GPIO. These interrupts will only trigger a wake if the Interrupt Detection field of the corresponding GPIO Pin Control Register is set to Rising Edge Triggered, Falling Edge Triggered, or Either Edge Triggered.

8.8.2.2 Wake-Only Events

Some devices which respond to an external master require the [96 MHz](#) clock domain to operate but do not necessarily require and immediate processing by the EC. Wake-only events provide the means to start the [96 MHz](#) clock domain without triggering an EC interrupt service routine. This events are grouped into a single GIRQ, GIRQ22. Events that are enabled in that GIRQ will start the clock domain when the event occurs, but will not invoke an EC interrupt. The SLEEP_ENABLE flags all remain asserted. If the activity for the event does not in turn trigger another EC interrupt, the CLOCK_REQUIRED for the block will re-assert and the configured sleep state will be re-entered.

8.8.3 INTERRUPT SUMMARY

Interrupt bit assignments, including wake capabilities and NVIC vector locations, are shown in the Interrupt Aggregator Bit Assignments Table in [Section 3.0, "Device Inventory"](#). The table lists all possible interrupt sources; the register bits for any interrupt source, such as a GPIO, that is not implemented in a particular part are reserved.

8.8.4 DISABLING INTERRUPTS

The [Block Enable Clear Register](#) and [Block Enable Set Register](#) should not be used for disabling and enabling interrupts for software operations i.e., critical sections. The ARM enable disable mechanisms should be used.

8.9 EC Registers

Registers for this block are shown in the following summary table. Addresses for each register are determined by adding the offset to the Base Address for of the [EC Interrupt Aggregator](#) Block in the Block Overview and Base Address Table in [Section 3.0, "Device Inventory"](#).

TABLE 8-4: REGISTER SUMMARY

Offset	Register Name
00h	GIRQ8 Source Register
04h	GIRQ8 Enable Set Register
08h	GIRQ8 Result Register
0Ch	GIRQ8 Enable Clear Register
10h	Reserved
14h	GIRQ9 Source Register
18h	GIRQ9 Enable Set Register
1Ch	GIRQ9 Result Register
20h	GIRQ9 Enable Clear Register
24h	Reserved

TABLE 8-4: REGISTER SUMMARY (CONTINUED)

Offset	Register Name
28h	GIRQ10 Source Register
2Ch	GIRQ10 Enable Set Register
30h	GIRQ10 Result Register
34h	GIRQ10 Enable Clear Register
38h	Reserved
3Ch	GIRQ11 Source Register
40h	GIRQ11 Enable Set Register
44h	GIRQ11 Result Register
48h	GIRQ11 Enable Clear Register
4Ch	Reserved
50h	GIRQ12 Source Register
54h	GIRQ12 Enable Set Register
58h	GIRQ12 Result Register
5Ch	GIRQ12 Enable Clear Register
60h	Reserved
64h	GIRQ13 Source Register
68h	GIRQ13 Enable Set Register
6Ch	GIRQ13 Result Register
70h	GIRQ13 Enable Clear Register
74h	Reserved
78h	GIRQ14 Source Register
7Ch	GIRQ14 Enable Set Register
80h	GIRQ14 Result Register
84h	GIRQ14 Enable Clear Register
88h	Reserved
8Ch	GIRQ15 Source Register
90h	GIRQ15 Enable Set Register
94h	GIRQ15 Result Register
98h	GIRQ15 Enable Clear Register
9Ch	Reserved
A0h	GIRQ16 Source Register
A4h	GIRQ16 Enable Set Register
A8h	GIRQ16 Result Register
ACH	GIRQ16 Enable Clear Register
B0h	Reserved
B4h	GIRQ17 Source Register
B8h	GIRQ17 Enable Set Register
BCh	GIRQ17 Result Register
C0h	GIRQ17 Enable Clear Register
C4h	Reserved
C8h	GIRQ18 Source Register
CCh	GIRQ18 Enable Set Register
D0h	GIRQ18 Result Register
D4h	GIRQ18 Enable Clear Register

TABLE 8-4: REGISTER SUMMARY (CONTINUED)

Offset	Register Name
D8h	Reserved
DCh	GIRQ19 Source Register
E0h	GIRQ19 Enable Set Register
E4h	GIRQ19 Result Register
E8h	GIRQ19 Enable Clear Register
ECh	Reserved
F0h	GIRQ20 Source Register
F4h	GIRQ20 Enable Set Register
F8h	GIRQ20 Result Register
FCh	GIRQ20 Enable Clear Register
100h	Reserved
104h	GIRQ21 Source Register
108h	GIRQ21 Enable Set Register
10Ch	GIRQ21 Result Register
110h	GIRQ21 Enable Clear Register
114h	Reserved
118h	GIRQ22 Source Register
11Ch	GIRQ22 Enable Set Register
120h	GIRQ22 Result Register
124h	GIRQ22 Enable Clear Register
128h	Reserved
12Ch	GIRQ23 Source Register
130h	GIRQ23 Enable Set Register
134h	GIRQ23 Result Register
138h	GIRQ23 Enable Clear Register
13Ch	Reserved
140h	GIRQ24 Source Register
144h	GIRQ24 Enable Set Register
148h	GIRQ24 Result Register
14Ch	GIRQ24 Enable Clear Register
150h	Reserved
154h	GIRQ25 Source Register
158h	GIRQ25 Enable Set Register
15Ch	GIRQ25 Result Register
160h	GIRQ25 Enable Clear Register
164h	Reserved
168h	GIRQ26 Source Register
16Ch	GIRQ26 Enable Set Register
170h	GIRQ26 Result Register
174h	GIRQ26 Enable Clear Register
200h	Block Enable Set Register
204h	Block Enable Clear Register
208h	Block IRQ Vector Register

All of the GIRQx Source, Enable Set, Enable Clear and Result registers have the same format. The following tables define the generic format for each of these registers. The bit definitions are defined in the sections that follow.

The behavior of the enable bit controlled by the GIRQx Enable Set and GIRQx Enable Clear Registers, the GIRQx Source bit, and the GIRQx Result bit is illustrated in [Section 8.8.1, "Aggregated Interrupts"](#).

8.9.1 GIRQ SOURCE REGISTERS

All of the GIRQx Source registers have the same format. The following table defines the generic format for each of these registers. The bit definitions are defined in the Interrupt Aggregator Bit Assignments Table in [Section 3.0, "Device Inventory"](#). Unassigned bits are Reserved and return 0.

Note: If a GPIO listed in the tables does not appear in the pin list of a particular device, then the bits for that GPIO in the GIRQx Source, GIRQx Enable Clear, GIRQx Enable Set and GIRQx Result are reserved.

Offset	See Section 3.0, "Device Inventory"			
Bits	Description	Type	Default	Reset Event
31	Reserved	RES	-	-
30:0	GIRQX_SOURCE The GIRQx Source bits are R/WC sticky status bits indicating the state of interrupt before the interrupt enable bit.	R/WC	0h	RESET_SYS

8.9.2 GIRQ ENABLE SET REGISTERS

All of the GIRQx Enable Set registers have the same format. The following table defines the generic format for each of these registers. Unassigned bits are Reserved and return 0.

Offset	See Section 3.0, "Device Inventory"			
Bits	Description	Type	Default	Reset Event
31	Reserved	RES	-	-
30:0	GIRQX_ENABLE_SET Each GIRQx bit can be individually enabled to assert an interrupt event. Reads always return the current value of the internal GIRQX_ENABLE bit. The state of the GIRQX_ENABLE bit is determined by the corresponding GIRQX_ENABLE_SET bit and the GIRQX_ENABLE_CLEAR bit. (0=disabled, 1-enabled) 1=The corresponding interrupt in the GIRQx Source Register is enabled 0=No effect	R/WS	0h	RESET_SYS

MEC1725

8.9.3 GIRQ ENABLE CLEAR REGISTERS

All of the GIRQx Enable Clear registers have the same format. The following table defines the generic format for each of these registers. Unassigned bits are Reserved and return 0.

Offset	See Section 3.0, "Device Inventory"			
Bits	Description	Type	Default	Reset Event
31	Reserved	RES	-	-
30:0	<p>GIRQX_ENABLE_CLEAR</p> <p>Each GIRQx bit can be individually enabled to assert an interrupt event.</p> <p>Reads always return the current value of the internal GIRQX_ENABLE bit. The state of the GIRQX_ENABLE bit is determined by the corresponding GIRQX_ENABLE_SET bit and the GIRQX_ENABLE_CLEAR bit. (0=disabled, 1-enabled)</p> <p>1=The corresponding interrupt in the GIRQx Source Register is disabled 0=No effect</p>	R/WC	0h	RESET_SYS

8.9.4 GIRQ RESULT REGISTERS

Offset	See Section 3.0, "Device Inventory"			
Bits	Description	Type	Default	Reset Event
31	Reserved	RES	1h	-
30:0	<p>GIRQX_RESULT</p> <p>The GIRQX_RESULT bits are Read-Only status bits indicating the state of an interrupt. The RESULT is asserted '1'b when both the GIRQX_SOURCE bit and the corresponding GIRQX_ENABLE bit are '1'b.</p>	R	0h	RESET_SYS

8.9.5 BLOCK ENABLE SET REGISTER

Offset	200h			
Bits	Description	Type	Default	Reset Event
31:27	Reserved	RES	-	-

Offset	200h			
Bits	Description	Type	Default	Reset Event
26:8	IRQ_VECTOR_ENABLE_SET Each bit in this field enables the group GIRQ interrupt assertion to the NVIC. 1=Interrupts in the GIRQx Source Register may be enabled 0=No effect	R/WS	0h	RESET_SYS
7:0	Reserved	RES	-	-

8.9.6 BLOCK ENABLE CLEAR REGISTER

Offset	204h			
Bits	Description	Type	Default	Reset Event
31:27	Reserved	RES	-	-
26:8	IRQ_VECTOR_ENABLE_CLEAR Each bit in this field disables the group GIRQ interrupt assertion to the NVIC. 1=Interrupts in the GIRQx Source Register are disabled 0=No effect	R/WC	0h	RESET_SYS
7:0	Reserved	RES	-	-

8.9.7 BLOCK IRQ VECTOR REGISTER

Offset	208h			
Bits	Description	Type	Default	Reset Event
31:27	Reserved	RES	0h	-
26:8	IRQ_VECTOR Each bit in this field reports the status of the group GIRQ interrupt assertion to the NVIC. If the GIRQx interrupt is disabled as a group, by the Block Enable Clear Register , then the corresponding bit will be '0'b and no interrupt will be asserted.	R	0h	RESET_SYS
7:0	Reserved	RES	0h	-

MEC1725

9.0 CHIP CONFIGURATION

9.1 Introduction

This chapter defines the mechanism to configure the device. Each logical device or block in the design has their own set of configuration registers. The Global Configuration Registers are used for chip-level configuration. The chip's Device ID and Revision are located in the Global Configuration space and may be used to uniquely identify this chip.

9.2 Terminology

This section documents terms used locally in this chapter. Common terminology that is used in the chip specification is captured in the Chip-Level Terminology section.

TABLE 9-1: TERMINOLOGY

Term	Definition
Global Configuration Registers	Registers used to configure the chip that are always accessible via the Configuration Port
Logical Device Configuration Registers	Registers used to configure a logical device in the chip. These registers are only accessible via the Configuration Port when enabled via the Global Configuration registers.

9.3 Interface

This block is designed to be accessed via the Host accessible Configuration Port.

FIGURE 9-1: BLOCK DIAGRAM OF CONFIGURATION PORT

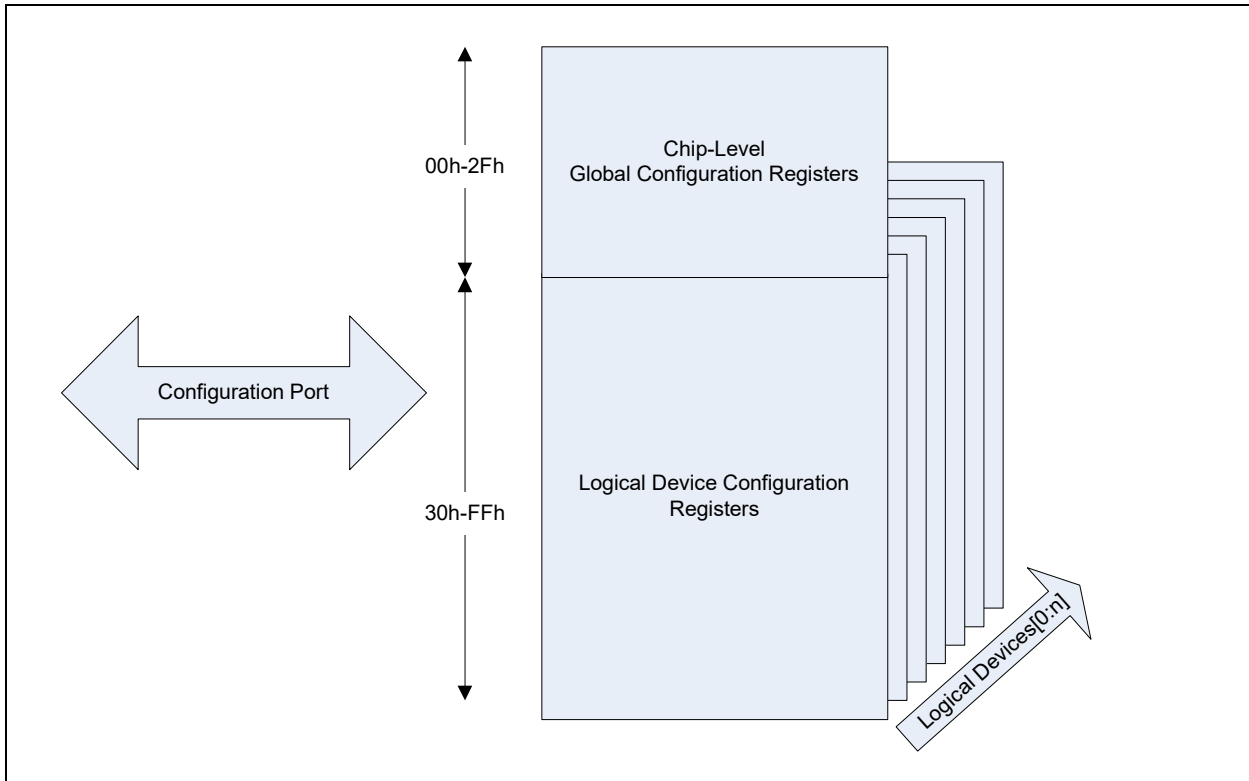

Note: Each logical device has a bank of Configuration registers that are accessible at offsets 30h to FFh via the Configuration Port. The Logical Device number programmed in offset 07h determines which bank of configuration registers is currently accessible.

9.4 Power, Clocks and Reset

This section defines the Power, Clock, and Reset input parameters to this block.

9.4.1 POWER DOMAINS

TABLE 9-2: POWER SOURCES

Name	Description
VTR_CORE	The logic and registers implemented in this block reside on this single power well.

9.4.2 CLOCK INPUTS

This block does not require any special clock inputs.

9.4.3 RESETS

TABLE 9-3: RESET SIGNALS

Name	Description
RESET_SYS	Power on Reset to the entire device. This signal resets all the register and logic in this block to its default state.
RESET_HOST	A reset that occurs when VCC is turned off or when the system host resets the Host Interface.
RESET_eSPI	For systems with eSPI, a general reset signal for the eSPI block.

9.5 Interrupts

This block does not generate any interrupts.

9.6 Low Power Modes

This block always automatically adjusts to operate in the lowest power mode.

9.7 Description

The Chip Configuration Registers are divided into two groups: Global Configuration Registers and Logical Device Configuration registers.

9.7.1 CONFIGURATION PORT

The eSPI Host can access the Chip's Configuration Registers through the Configuration Port when CONFIG MODE is enabled.

Note: The data read from the Configuration Port Data register is undefined when CONFIG MODE is not enabled.

The Configuration Port is composed of an INDEX and DATA Register. The INDEX register is used as an address pointer to an 8-bit configuration register and the DATA register is used to read or write the data value from the indexed configuration register. Once CONFIG MODE is enabled, reading the Configuration Port Data register will return the data value that is in the indexed Configuration Register.

MEC1725

If no value was written to the INDEX register, reading the Data Register in the Configuration Port will return the value in Configuration Address location 00h (default).

TABLE 9-4: CONFIGURATION PORT

Default I/O Address	Type	Register Name	Relative Address	Default Value	Notes
002Eh	Read / Write	INDEX	Configuration Port's Base Address + 0	00h	Note 1
002Fh	Read / Write	DATA	Configuration Port's Base Address + 1	00h	

Note 1: The default Base I/O Address of the Configuration Port can be relocated by programming the BAR register for Logical Device Ch (eSPI, I/O Configuration Port). The Relative Address shows the general case for determining the I/O address for each register.

9.7.2 ENABLE CONFIG MODE

The INDEX and DATA registers are effective only when the chip is in CONFIG MODE. CONFIG MODE is enabled when the Config Entry Key is successfully written to the I/O address of the INDEX register of the CONFIG PORT while the CONFIG MODE is disabled (see following section).

Config Entry Key = < 55h>

9.7.3 DISABLE CONFIG MODE

CONFIG MODE defaults to disabled on a [RESET_SYS](#), [RESET_HOST](#), and, for systems using eSPI, when [RESET_HOST](#) is asserted. CONFIG MODE is also disabled when the following Config Exit Key is successfully written to the I/O address of the INDEX PORT of the CONFIG PORT while CONFIG MODE is enabled.

Config Exit Key = < AAh>

9.7.4 CONFIGURATION SEQUENCE EXAMPLE

To program the configuration registers, the following sequence must be followed:

1. Enable Configuration State
2. Program the Configuration Registers
3. Disable Configuration State.

The following is an example of a configuration program in Intel 8086 assembly language.

```
;-----  
; ENABLE CONFIGURATION STATE  
;-----  
MOV     DX,CONFIG_PORT_BASE_ADDRESS  
MOV     AX,055H; Config Entry Key  
OUT     DX,AL  
;-----  
; CONFIGURE BASE ADDRESS, |  
; LOGICAL DEVICE 8      |  
;-----  
MOV     DX,CONFIG_PORT_BASE_ADDRESS  
MOV     AL,07H  
OUT     DX,AL; Point to LD# Config Reg  
MOV     DX,CONFIG_PORT_BASE_ADDRESS+1  
MOV     AL, 08H  
OUT DX,AL; Point to Logical Device 8  
;  
MOV     DX,CONFIG_PORT_BASE_ADDRESS  
MOV     AL,34H  
OUT     DX,AL ; Point to BASE ADDRESS REGISTER  
MOV     DX,CONFIG_PORT_BASE_ADDRESS+1  
MOV     AL,02H  
OUT     DX,AL ; Update BASE ADDRESS REGISTER
```



```

;----- .
; DISABLE CONFIGURATION STATE
;----- '
MOV    DX,CONFIG_PORT_BASE_ADDRESS
MOV    AX,0AAH; Config Exit Key
OUT    DX,AL.

```

9.7.5 GLOBAL CONFIGURATION

There are 48 8-bit Global Configuration Registers (at offsets 00h through 2Fh), plus up to 208 8-bit registers associated with each Logical Device. The Logical Device is selected with the [Logical Device Number](#) Register (Global Configuration Register 07h).

Sequence to Access Logical Device Configuration Register:

- a) Write the number of the Logical Device being accessed in the [Logical Device Number](#) Configuration Register by writing 07h into the INDEX PORT and the [Logical Device Number](#) into the DATA PORT.
- b) Write the address of the desired logical device configuration register to the INDEX PORT and then write or read the value of the configuration register through the DATA PORT.

Note: If accessing the Global Configuration Registers, step (a) is not required.
Any write to an undefined or reserved Configuration register is terminated normally on the eSPI bus without any modification of state in the MEC1725. Any read to an undefined or reserved Configuration register returns FFh

The following sections define the Global Configuration registers and the Logical Configuration registers.

9.7.6 GLOBAL CONTROL/CONFIGURATION REGISTERS

As with all Configuration Registers, the INDEX PORT is used to select a Global Configuration Register in the chip. The DATA PORT is then used to access the selected register. The INDEX and DATA PORTs are defined in the eSPI Interface description.

9.8 Configuration Registers

Host access to Global Configuration Registers is through the Configuration Port (the INDEX PORT and the DATA PORT) using the Logical Device Number 3Fh and the Index shown in the "Offset" column of the following table. The EC can access Configuration Registers directly. The EC address for each register is formed by adding the Base Address for Global Configuration block shown in the Block Overview and Base Address Table in [Section 3.0, "Device Inventory"](#) to the offset shown in the "Offset" column.

All Global Configuration registers are accessible to the Host through the Configuration Port for all Logical Devices. at offsets 00h through 2Fh.

TABLE 9-5: CHIP-LEVEL (GLOBAL) CONTROL/CONFIGURATION REGISTERS

Register	Host Offset	Description
Chip (Global) Control Registers		
Reserved	00h - 01h	Reserved - Writes are ignored, reads return 0.
TEST	02h	TEST. This register location is reserved for Microchip use. Modifying this location may cause unwanted results.
Reserved	03h - 06h	Reserved - Writes are ignored, reads return 0.
Logical Device Number	07h	A write to this register selects the current logical device. This allows access to the control and configuration registers for each logical device. Note: The Activate command operates only on the selected logical device.

MEC1725

TABLE 9-5: CHIP-LEVEL (GLOBAL) CONTROL/CONFIGURATION REGISTERS (CONTINUED)

Register	Host Offset	Description
Reserved	08h - 18h	Reserved - Writes are ignored, reads return 0.
Device Revision	1Ch	A read-only register which provides device revision information.
Device Sub ID	1Dh	Read-Only register which provides the device sub-identification.
Device ID[7:0]	1Eh	Read-Only register which provides Device ID LSB.
Device ID[15:8]	1Fh	Read-Only register which provides Device ID MSB.
Legacy Device ID	20h	A read-only register which provides Legacy device identification. The value of this register is FEh
TEST	22h - 23h	TEST. This register locations are reserved for Microchip use. Modifying these locations may cause unwanted results.
OTP ID	24h	This register contains the OTP ID.
Validation ID	25h	This register contains the Validation ID
Boot ROM Revision ID	26-27h	This register contains the Boot ROM revision ID
TEST	28h - 2Fh	TEST. This register locations are reserved for Microchip use. Modifying these locations may cause unwanted results.

Note: [Device Revision](#) reports Current Revision and is Read-Only.

10.0 ENHANCED SERIAL PERIPHERAL INTERFACE (ESPI)

10.1 Introduction

The Intel® Enhanced Serial Peripheral Interface (eSPI) is Intel's successor to the Low Pin Count (LPC) bus, used in previous devices to provide System Host access to devices internal to the Embedded Controller. In addition, multiplexed on the same physical pins, there are separate eSPI Channels: one transferring Host IRQs and other discrete pin inputs and outputs; another substituting for one or more SMBus channels; and another providing shared access to the BIOS Flash memory, attached either to the Chipset or to the EC device.

The Peripheral Channel is the LPC replacement capability, which provides for I/O-Mapped and Memory-Mapped access to on-chip peripheral devices, with Plug-and-Play Configuration capability preserved. In addition, regions of the EC's internal memory space may be made available to the Host CPU directly, and Legacy DMA is replaced with Mastering capability so that the EC firmware may communicate with System DRAM.

The Virtual Wire Channel propagates IRQs to the Host system, replacing the Serial IRQ mechanism. It also provides a transport mechanism for other sideband signals such as SLP_Sx#, SMI#, SCI# and PLTRST#/PCI_RESET#.

The Out-of-Band (OOB) Channel provides a replacement for serial connections to the Chipset, replacing the SMLink1 port for PCH temperature and RTC readings, the PECEI port for CPU temperature reading, and communication with the PCH's Management Engine for other purposes previously performed over SMBus.

The Flash Channel performs BIOS Flash Memory sharing. In Master-Attached (MAFS) configuration, the Chipset still connects to the Flash and shares with the EC over eSPI, also allowing the EC to load its firmware from it. In Slave-Attached (SAFS) configuration, the Flash is connected to the EC, which shares with the Chipset over eSPI, providing all information including low-level data such as Soft Straps and Management Engine firmware. Intel's Descriptor Mode protection mechanism is preserved in both configurations.

This chapter documents those registers whose offsets may change from product to product; especially those associated with Plug-and-Play configuration. For full details of the eSPI Block register set, see the Microchip document "eSPI Controller with SAFS Support, Version 1.4" [1].

10.2 References

1. Microchip "eSPI Controller with SAFS Support, Version 1.4" Specification
2. Intel, *Enhanced Serial Peripheral Interface (eSPI): Interface Base Specification*
3. Intel, *eSPI Compatibility Specification for the specific Chipset*
4. Intel, *SPI Programming Guide for the specific Chipset*
5. The ROM Description Addendum document MEC1725

10.3 Terminology

This table defines specialized terms localized to this feature.

TABLE 10-1: TERMINOLOGY

Term	Definition
System Host	Refers to the external CPU that communicates with this device via the eSPI Interface.
Logical Devices	Logical Devices are System Host-accessible features that are allocated a Base Address and range in the System Host I/O address space

MEC1725

TABLE 10-1: TERMINOLOGY

Term	Definition
Runtime Register	Runtime Registers are registers that are directly I/O accessible by the System Host via the eSPI interface.
Configuration Registers	Registers that are only accessible in CONFIG_MODE.
EC_Only Registers	Registers that are not accessible by the System Host. They are only accessible by an internal embedded controller.

10.4 Interface

FIGURE 10-1: Enhanced Serial Peripheral Interface (eSPI) INTERFACE DIAGRAM

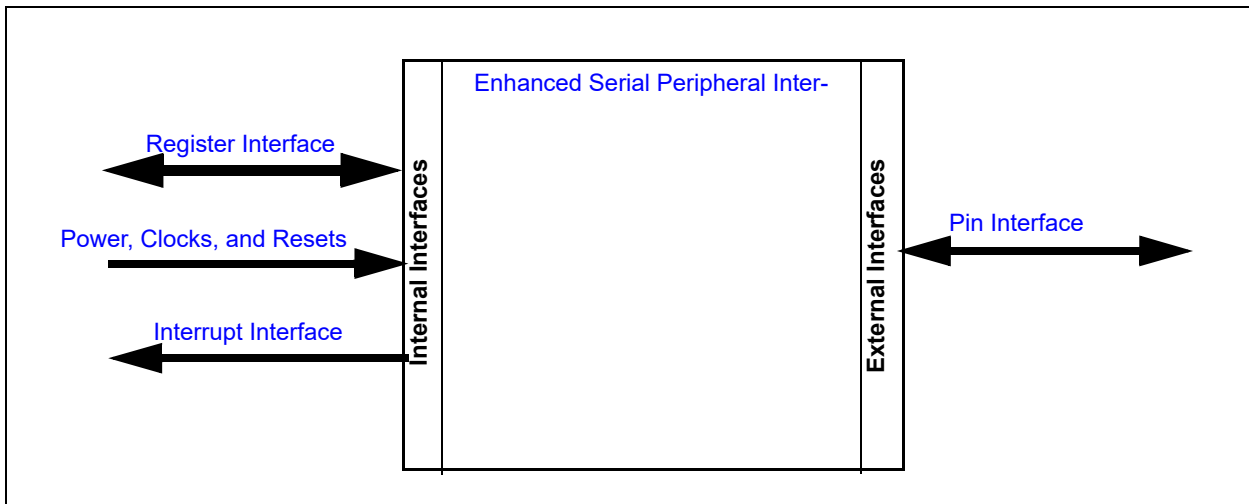

10.4.1 PIN INTERFACE

Table 10-2, "Signal Description Table" lists the signals that are typically routed to the pin interface.

TABLE 10-2: SIGNAL DESCRIPTION TABLE

Signal Name	Direction	Description
eSPI_CS#	Input	eSPI Chip Select, Low-Active
eSPI_CLOCK	Input	eSPI Clock
eSPI_ALERT#	Output	eSPI Alert signal, Low-Active. Exercised only if ALERT# is configured to be presented separately from the IO1 pin.
eSPI_RESET#	Input	POR for eSPI bus power domain, and a Reset for serious errors. Low-Active.
eSPI_IO0	Input/Output	eSPI Data Bus, bit 0. Input (MOSI) in x1 Bus Mode. Else, it holds the LS data bit.
eSPI_IO1	Input/Output	eSPI Data Bus, bit 1. Output (MISO) in x1 Bus Mode. Also, by default, presents ALERT# state between frames.
eSPI_IO2	Input/Output	eSPI Data Bus, bit 2. Used only in x4 mode.
eSPI_IO3	Input/Output	eSPI Data Bus, bit 3. Used only in x4 mode, as MS bit.

10.4.2 REGISTER INTERFACE

Each of the four channels contains registers that may be accessed by both the Host and the EC, as well as a set of registers that can only be accessed by the EC.

10.4.3 POWER, CLOCKS, AND RESETS

This section defines the Power, Clock, and Reset parameters associated with this IP block.

10.4.3.1 Power

Name	Description
VTR_CORE	The Enhanced Serial Peripheral Interface (eSPI) block and registers are powered by VTR_CORE. This power rail may be present to the block while external power to the eSPI pins is not present. Therefore, this block remains passive on the eSPI bus pins whenever eSPI_RESET# is low.

10.4.3.2 Clocks

This section describes all the clocks in the block, including those that are derived from the I/O Interface as well as the ones that are derived or generated internally.

Name	Description
96 MHz	The main internal clock
eSPI_CLOCK	The eSPI clock provided by the System Host core logic Note: Max frequency supported is 66MHz for 1 Load.

10.4.3.3 Resets

This section describes all the resets associated with this IP block, including those that are derived from the I/O Interface as well as the ones that are derived or generated internally.

Name	Description
RESET_SYS	This is the power-on-reset signal, which is asserted when VTR_CORE power is applied. Asserting this reset signal resets the eSPI IP block, including all registers, FIFOs, and state machines to their initial POR state.

MEC1725

Name	Description
RESET_eSPI	<p>A general reset signal for the eSPI block. This reset is asserted with the eSPI_RESET# pin is asserted by the System Host core logic.</p> <p>When this reset is asserted all eSPI Output signals and Input/Output signals are tri-stated. Any transaction in progress is terminated and all FIFOs are flushed. All interrupt status flags are reset and all interrupts to the EC except RESET_eSPI are suppressed.</p> <p>When this reset is asserted, all eSPI Configuration Registers in the slave device are set to the default values, as per the Intel eSPI Specification. Fields in the eSPI Configuration Registers that are set from the eSPI Capabilities registers (see Section 10.7, "eSPI Register Summary") are not modified.</p> <p>This reset is also asserted in the following cases: RESET_SYS is asserted</p>
RESET_VCC	Performs a reset when the system main power rail is turned off.
RESET_HOST	Performs a reset when the system main power rail is turned off or when the system host resets the Host Interface.
eSPI_PLTRST#	<p>This is a reset that affects the Peripheral Channel. It is received by the Slave as a Virtual Wire (PLTRST#) or through PCI_RESET# pin.</p> <p>This reset is also asserted in the following cases:</p> <ul style="list-style-type: none"> RESET_SYS is asserted RESET_eSPI is asserted The Peripheral Channel is disabled

Note: Once the PCH asserts the HOST_RST_WARN Virtual Wire and once the EC firmware asserts HOST_RST_ACK virtual wire, it must not send any upstream peripheral channel traffic nor virtual wire traffic that is on the PLTRST reset domain once ACK is sent.

6.

10.4.4 INTERRUPT INTERFACE

This section defines the interrupt Interface signals routed to the chip interrupt aggregator.

Source	Description
Wake Only Event	
ESPI_WAKE_ONLY	This signal is asserted when the eSPI interface detects eSPI traffic. If enabled, it may be used to wake the main clock domain when the chip is in a sleep state.
Peripheral Channel	
INTR_PC	Peripheral Channel Interrupt
INTR_BM1	Bus Mastering Channel 1 Interrupt
INTR_BM2	Bus Mastering Channel 2 Interrupt

Source	Description
INTR_LTR	Peripheral Message (LTR) Interrupt
OOB Channel	
INTR_OOB_UP	Out of Band Channel Up Interrupt
INTR_OOB_DOWN	Out of Band Channel Down Interrupt
Flash Channel	
INTR_FLASH	Flash Channel Interrupt
EC_CMLPTN	EC Completion Event Interrupt-SAF mode
ESPI_ERROR	ESPI Error Event Interrupt-SAF mode
Virtual Wires Channel	
MSVW[00:10]_SRC[3:0]	Master-to-Slave Virtual Wire Interrupts
eSPI Global	
eSPI_RESET	eSPI Reset Interrupt This interrupt is generated whenever the external eSPI_RESET# pin changes state.

10.5 Low Power Modes

The eSPI block can enter a low power state when it is not in operation. When the eSPI block is operational it will keep the main system clock from shutting down and entering its sleep state. When the eSPI_CS# pin is asserted the eSPI block will wake the main system clock, if it is in a sleep state, and keep the system clock in its active state until the transaction started by the Master has completed.

The low power behavior of the block is controlled by the [BAR Inhibit Register](#). The block is not affected by a SLEEP_ENABLE signal from the chip's Power, Clocks and Resets unit.

10.6 Description

The eSPI interface consists of four channels:

- [eSPI Peripheral Channel Interface](#)
- [eSPI Out Of Band Channel Interface](#)
- [eSPI Flash Channel Interface](#)
- [eSPI Virtual Wires Interface](#)

These four channels are multiplexed onto the eSPI physical interface that connects the Embedded Controller device with the core logic of the Host. The following figure illustrates this multiplexing:

FIGURE 10-2: ESPI BLOCK DIAGRAM

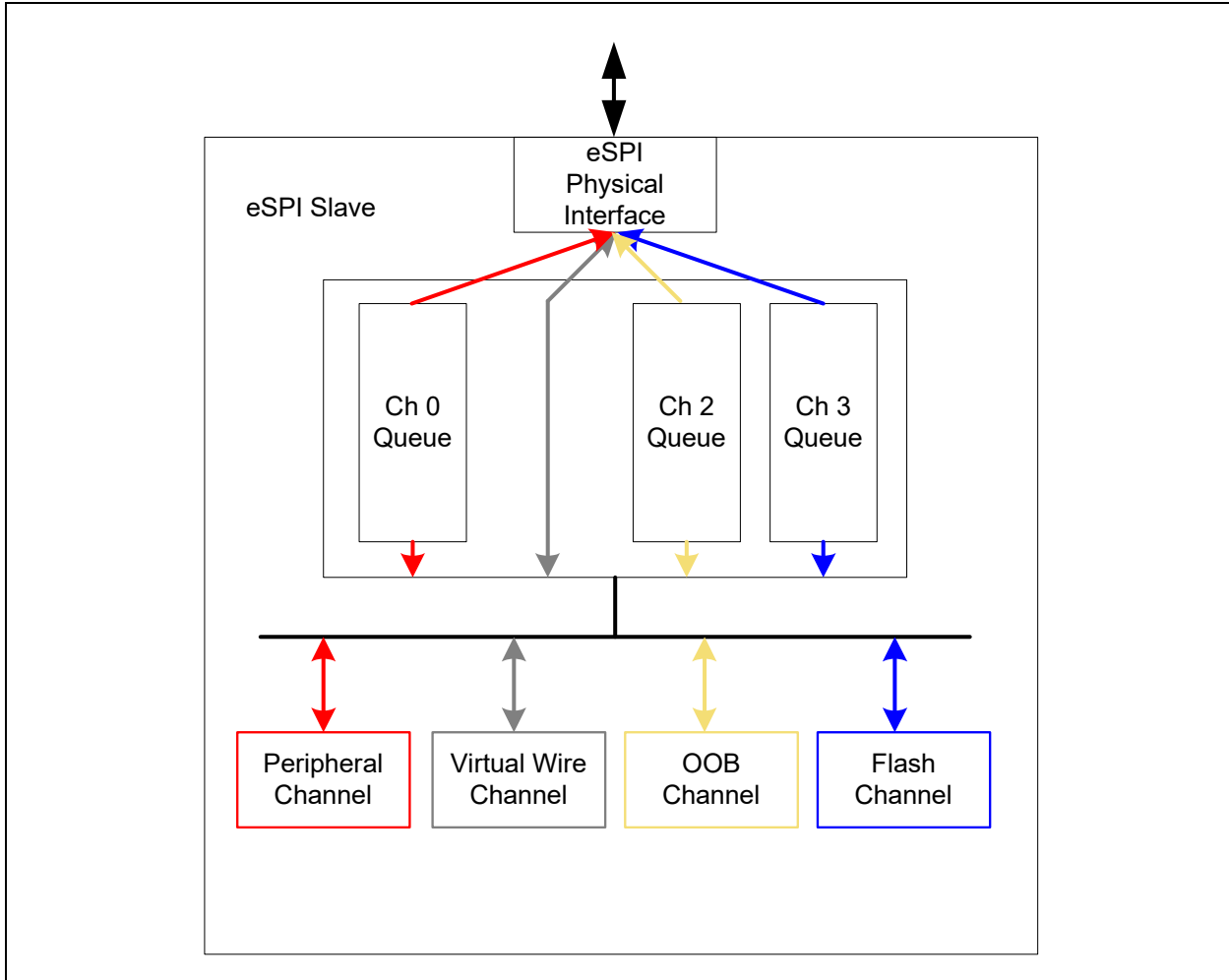

The Peripheral Channel (PC) enables the system Host to read and write locations inside the EC. The PC encapsulates legacy I/O and Memory-Mapped I/O operation as well as generic memory read and write operations in both directions. EC can take control of Peripheral Channel and become the Bus Master. In this mode EC can transmit bulk data of size up to 4K to host memory directly. eSPI peripheral channel Interface chapter in eSPI block spec describes the settings for this mode.

The Virtual Wire Channel provides in-band emulation of sideband pin signals between the system Core Logic and the EC, including the legacy SERIRQ interrupt link to the system Host.

The Out of Band (OOB) Channel enables messaging between the Out-Of-Band Processor in the system chipset and the EC. This messaging is implemented by tunneling SMBus packets over the eSPI port.

The Flash Channel allows sharing of a Flash memory between the system Host and the EC. The Flash may be connected to either side (Host or EC), and is shared over eSPI with the other. A strap pin on the Chipset defines which direction the Flash traffic follows.

Note: If prefetch feature in eSPI block is enabled and if master wishes to write and then read the same address in the Flash in the exact sequence, then, either reading another location from the Flash first after Writing, or reading the 64 bytes back twice, or reading them back as anything other than exactly 64 aligned bytes (such as 32 bytes twice) is required.

Note: It is recommended to have a termination resistor on the PCB for the eSPI pins. Please refer to PCB layout guide for the recommended values of the termination resistor.

10.7 eSPI Register Summary

The following sections list the registers associated with the eSPI logic that may vary among products. The eSPI logic requires two Logical Devices in order to provide access to all the required registers. These Logical Devices are called the I/O Component and the Memory Component. The Base Addresses for these blocks are shown in the Block Overview and Base Address Table in [Section 3.0, "Device Inventory"](#).

The EC may access all registers in both Logical Devices. Host access is restricted to three ranges: Runtime Registers, located at offsets 00h through FFh from the Logical Device Base Address of the I/O Component, and Configuration Registers, located at offsets 330h through 3FFh in both the I/O Component and the Memory Component. The Runtime Registers may be mapped into the Hosts address space, either I/O or Memory, by setting the associated BAR for the Logical Device. The Configuration Registers are accessed through the Configuration Port. Registers located at offsets 330h through 3FFh are mapped to Configuration Port offsets 30h through FFh. Configuration Port offsets 00h through 2Fh, for all Host Logical Devices, are mapped to the Global Configuration Registers.

10.7.1 REGISTER SPACES

Each of the register spaces (eSPI I/O Component, eSPI Memory Component, Virtual Wire Component, SAF Communication and SAF Bridge Component) are assigned base addresses.

The base address of each of the eSPI components is shown in [Table 3-1, "Base Address"](#).

10.7.2 ESPI I/O COMPONENT

TABLE 10-3: ESPI I/O COMPONENT REGISTER SUMMARY

INDEX 2	Host Offset 3	EC Offset 1	Register Name
RUNTIME REGISTERS			
Peripheral Channel			
-	00h	00h	INDEX Register
-	01h	01h	DATA Register
EC PRIVATE REGISTERS			
Peripheral Channel			
	-	120h	BAR Inhibit Register
	-	128h	eSPI Bar Init Register
	-	134h - 1A7h	I/O Base Address Register Format, Internal Component See Table 10-6, "ESPI I/O Base Address Register Default Values" Note
Note: Please refer to Microchip "eSPI Controller with SAFS Support, Version 1.3" Specification [1.] for the complete register set			
CONFIGURATION REGISTERS			
Peripheral Channel			
30h	-	330h	eSPI Activate Register
34h - 8Ch	-	334h - 38Ch	I/O Space Base Address Registers (BARs) See Table 10-6, "ESPI I/O Base Address Register Default Values"
Virtual Wire Channel			
ACh - BFh	-	3ACh - 3BFh	IRQ Selection. See Table 10-11, "IRQ Assignment Table"
C0h-EFh	-	3C0h-3EFh	Reserved
F0h	-	3F0h	eSPI Virtual Wire Errors

MEC1725

Note 1: eSPI Interface IO Component Base Address is defined in [Device Inventory](#) chapter.

2: Value is written to the INDEX Register.

3: Value offset from eSPI I/O Component. See [Table 10-6, "ESPI I/O Base Address Register Default Values"](#) for details.

10.7.3 ESPI, MEMORY COMPONENT REGISTERS

TABLE 10-4: ESPI MEMORY COMPONENT REGISTER SUMMARY

INDEX 2	EC Offset 1	Host Offset
EC PRIVATE REGISTERS		
Peripheral Channel		
-	130h-164h	Memory Base Address Register, Internal Component See Table 10-7, "ESPI Memory Base Address Register Default Values"
-	1ACh-1FFh	SRAM Base Address Register Format, Internal Component See Table 10-8, "SRAM Base Address Register Default Values, Host Config" Note
CONFIGURATION REGISTERS		
30h-A7h	330h-3A7h	Memory Base Address Configuration Register See Table 10-7, "ESPI Memory Base Address Register Default Values"
A8h	3A8	Host MEM BAR Extend Register (16 bits)
ACh-BFh	3ACh-3BFh	SRAM Base Address Configuration Register See Table 10-10, "SRAM Base Address Register Default Values, EC-Only"
C0h - F7h	3C0h - 3F7h	Reserved
FCh	3FCh	SRAM BAR Extend Register (16 bits)

Note 1: eSPI Interface IO Component Base Address is defined in [Device Inventory](#) chapter.

2: Value is written to the Configuration Port INDEX Register.

10.7.4 VIRTUAL WIRE REGISTERS

The following registers are allocated in the Virtual Wire Component space. The MSVWxx registers hold Master-to-Slave Virtual Wires transmitted from the Chipset to the EC. The SMVWxx registers hold Slave-to-Master Virtual Wires transmitted from the EC to the Chipset.

Their offsets may differ from product to product. Their formats, and the assignments of the Virtual Wires to register bits, are defined in the Microchip document "eSPI Controller with SAFS Support, Version 1.3". Refer to the registers by name there, which will match the names defined here.

TABLE 10-5: VIRTUAL WIRES REGISTER SUMMARY

EC Offset	Register Name
0h	MSVW00 Register
Ch	MSVW01 Register
18h	MSVW02 Register
24h	MSVW03 Register
30h	MSVW04 Register
3Ch	MSVW05 Register
48h	MSVW06 Register
54h	MSVW07 Register

TABLE 10-5: VIRTUAL WIRES REGISTER SUMMARY (CONTINUED)

EC Offset	Register Name
60h	MSVW08 Register
6Ch	MSVW09 Register
78h	MSVW10 Register
84h - 1FFh	Reserved
200h	SMVW00 Register
208h	SMVW01 Register
210h	SMVW02 Register
218h	SMVW03 Register
220h	SMVW04 Register
228h	SMVW05 Register
230h	SMVW06 Register
238h	SMVW07 Register
240h	SMVW08 Register
248h	SMVW09 Register
250h	SMVW10 Register
242h - 3FFh	Reserved

10.8 Base Address Register Tables

TABLE 10-6: ESPI I/O BASE ADDRESS REGISTER DEFAULT VALUES

Host Config Index	EC Offset	Logical Device	Reset Default	EC-Only Offset	Reset Default	LDN	MASK
34h	334h	eSPI I/O Component (Configuration Port)	XXXX_0000h 1	134h	0000_0D01h	Dh	1h
38h	338h	eSPI Memory Component	0000_0000h	138h	0000_0E00h	Eh	0h
3Ch	33Ch	Mailbox	0000_0000h	13Ch	0000_0001h	0h	1h
40h	340h	8042 Emulated Keyboard Controller	0060_0000h	140h	0000_0104h	1h	4h
44h	344h	ACPI EC Channel 0	0062_0000h	144h	0000_0204h	2h	4h
48h	348h	ACPI EC Channel 1	0000_0000h	148h	0000_0307h	3h	7h
4Ch	34Ch	ACPI EC Channel 2	0000_0000h	14Ch	0000_0407h	4h	7h
50h	350h	ACPI EC Channel 3	0000_0000h	150h	0000_0507h	5h	7h
54h	354h	ACPI EC Channel 4	0000_0000h	154h	0000_0607h	6h	7h
58h	358h	ACPI PM1	0000_0000h	158h	0000_0707h	7h	7h
5Ch	35Ch	Legacy (Fast Keyboard)	0092_0000h	15Ch	0000_0800h	8h	
60h	360h	UART 0	0000_0000h	160h	0000_0907h	9h	7h
64h	364h	UART 1	0000_0000h	164h	000_0A07h	Ah	7h
68h	368h	Embedded Memory Interface (EMI) 0	0000_0000h	168h	0000_101Fh	10h	1Fh
6Ch	36Ch	Embedded Memory Interface (EMI) 1	0000_0000h	16Ch	0000_111Fh	11h	1Fh
70h	370h	Embedded Memory Interface (EMI) 2	0000_0000h	170h	0000_121Fh	12h	1Fh

MEC1725

TABLE 10-6: ESPI I/O BASE ADDRESS REGISTER DEFAULT VALUES

Host Config Index	EC Offset	Logical Device	Reset Default	EC-Only Offset	Reset Default	LDN	MASK
74h	374h	BIOS Debug Port (Port 80)	0000_0000h	174h	0000_2003h	20h	3h
78h	378h	BIOS Debug Port Alias	0000_0000h	178h	0000_2100h	21h	0h
7Ch	37Ch	RTC	0000_0000h	17Ch	0000_141Fh	14h	1Fh
84h	384h	32 Byte Test Block	0000_0000h	184h	0000_2F1Fh	2Fh	1Fh
8Ch	38Ch	Glue	0000_0000h	18Ch	0000_0F07h	Fh	7h

Note 1: The higher 16bits (XXXX) come from the BAR INIT Register. See Microchip “eSPI Controller with SAFS Support, Version 1.4” Specification for details.

TABLE 10-7: ESPI MEMORY BASE ADDRESS REGISTER DEFAULT VALUES

Host Config Index	EC Offset	Logical Device	Reset Default	EC-Only Offset	Reset Default	LDN	MASK
30h	330h	Mailbox	00_0000h	130h	0000_0001h	0h	1h
3Ah	33Ah	ACPI EC Channel 0	62_0000h	13Ah	0000_0204h	2h	4h
44h	344h	ACPI EC Channel 1	00_0000h	144h	0000_0307h	3h	7h
4Eh	34Eh	ACPI EC Channel 2	00_0000h	14Eh	0000_0407h	4h	7h
58h	358h	ACPI EC Channel 3	00_0000h	158h	0000_0507h	5h	7h
62h	362h	ACPI EC Channel 4	00_0000h	162h	0000_0607h	6h	7h
6Ch	36Ch	Embedded Memory Interface (EMI) 0	00_0000h	16Ch	0000_101Fh	10h	1Fh
76h	376h	Embedded Memory Interface (EMI) 1	00_0000h	176h	0000_111Fh	11h	1Fh
80h	380h	Embedded Memory Interface (EMI) 2	00_0000h	180h	0000_121Fh	12h	1Fh
8Ah	38Ah	32 Byte Test Block	00_0000h	164h	0000_2F1Fh	2Fh	1Fh

TABLE 10-8: SRAM BASE ADDRESS REGISTER DEFAULT VALUES, HOST CONFIG

Host Config Index	Logical Device	Reset Default	Host Address [47:16]	Size [7:4]	Access [2:1]
ACh	SRAM BAR 0	0h	0h	0h	0h
B6h	SRAM BAR 1	0h	0h	0h	0h

Note: The Host Address field will be zero by default until the Host writes something there, but the Size and Access fields (and therefore the Reset Default) may be re-initialized by Firmware and seen as non-zero values (read-only) by the Host.

TABLE 10-9: HOST ADDRESS EXTEND REGISTER DEFAULT VALUES, HOST CONFIG

Host Config Index	Memory / SRAM BAR Extend	Reset Default
3A8h	HOST MEM BAR	0h
3FCh	SRAM BAR	0h

TABLE 10-10: SRAM BASE ADDRESS REGISTER DEFAULT VALUES, EC-ONLY

EC Offset	Logical Device	Reset Default	Base Address [47:16]	Size [7:4]	Access [2:1]	Valid [0]
1ACh	SRAM BAR 0	00h	0h	0h	0h	0h
1B6h	SRAM BAR 1	00h	0h	0h	0h	0h

10.9 IRQ Table

TABLE 10-11: IRQ ASSIGNMENT TABLE

HOST CONFIG INDEX	EC OFFSET	INSTANCE NAME	INSTANCE NUMBER	INTERRUPT SOURCE	DEFAULT VALUE
ACh	3ACh	Mailbox	0	MBX_Host_SIRQ	FFh
ADh	3ADh	Mailbox	0	MBX_Host_SMI	FFh
ACh	3AEh	8042	0	KIRQ	FFh
AFh	3AFh	8042	0	MIRQ	FFh
B0h	3B0h	ACPI EC	0	EC_OBF	FFh
B1h	3B1h	ACPI EC	1	EC_OBF	FFh
B2h	3B2h	ACPI EC	2	EC_OBF	FFh
B3h	3B3h	ACPI EC	3	EC_OBF	FFh
B4h	3B4h	ACPI EC	4	EC_OBF	FFh
B5h	3B5h	UART	0	UART	FFh
B6h	3B6	UART	1	UART	FFh
B7h	3B7h	EMI	0	Host Event	FFh
B8h	3B8h	EMI	0	EC-to-Host	FFh
B9h	3B9h	EMI	1	Host Event	FFh
BAh	3BAh	EMI	1	EC-to-Host	FFh
BBh	3BBh	EMI	2	Host Event	FFh
BCh	3BCh	EMI	2	EC-to-Host	FFh
BDh	3BDh	RTC	0	RTC	FFh
BEh	3BEh	EC	0	EC_IRQ	FFh

MEC1725

10.10 Virtual Wires Table

TABLE 10-12: MASTER-TO-SLAVE VIRTUAL WIRE REGISTERS

Offset	Instance Name	Default Value
0h	MSVW00	00000000_04040404_00000002h
Ch	MSVW01	00000000_04040404_00000003h
18h	MSVW02	00000000_04040404_00000307h
24h	MSVW03	00000000_04040404_00000041h
30h	MSVW04	00000000_04040404_00000042h
3Ch	MSVW05	00000000_04040404_00000043h
48h	MSVW06	00000000_04040404_00000044h
54h	MSVW07	00000000_04040404_00000347h
60h	MSVW08	00000000_04040404_0000004Ah
6Ch	MSVW09	00000000_04040404_00000000h
78h	MSVW10	00000000_04040404_00000000h

TABLE 10-13: SLAVE-TO-MASTER VIRTUAL WIRE REGISTERS

Offset	Instance Name	Default Value
200h	SMVW00	01010000_0000C004h
208h	SMVW01	00000000_00000005h
210h	SMVW02	00010101_00007306h
218h	SMVW03	00000000_00000040h
220h	SMVW04	00000000_00000045h
228h	SMVW05	00000000_00000046h
230h	SMVW06	00000000_00000000h
238h	SMVW07	00000000_00000000h
240h	SMVW08	00000000_00000000h
248h	SMVW09	00000000_00000000h
250h	SMVW10	00000000_00000000h

11.0 I2C/SMBUS INTERFACE

11.1 Introduction

This section describes the Power Domain, Resets, Clocks, Interrupts, Registers and the Physical Interface of the I2C/SMBus interface. In I2C mode, this block supports Promiscuous mode when configured as I2C slave. For a General Description, Features, Block Diagram, Functional Description, Registers Interface and other core-specific details, see Ref [1] (note: in this chapter, *italicized text* typically refers to SMB-I2C Controller core interface elements as described in Ref [1]).

11.2 References

1. "I2C_SMB Controller Core with Network Layer Support (SMB2) - 16MHz I2C Baud Clock", Revision 3.7, Core-Level Architecture Specification, Microchip, date 13 May 2020

11.3 Terminology

There is no terminology defined for this chapter.

11.4 Interface

This block is designed to be accessed externally via the pin interface and internally via a registered host interface. In addition, this block is equipped with:

FIGURE 11-1: I/O DIAGRAM OF BLOCK

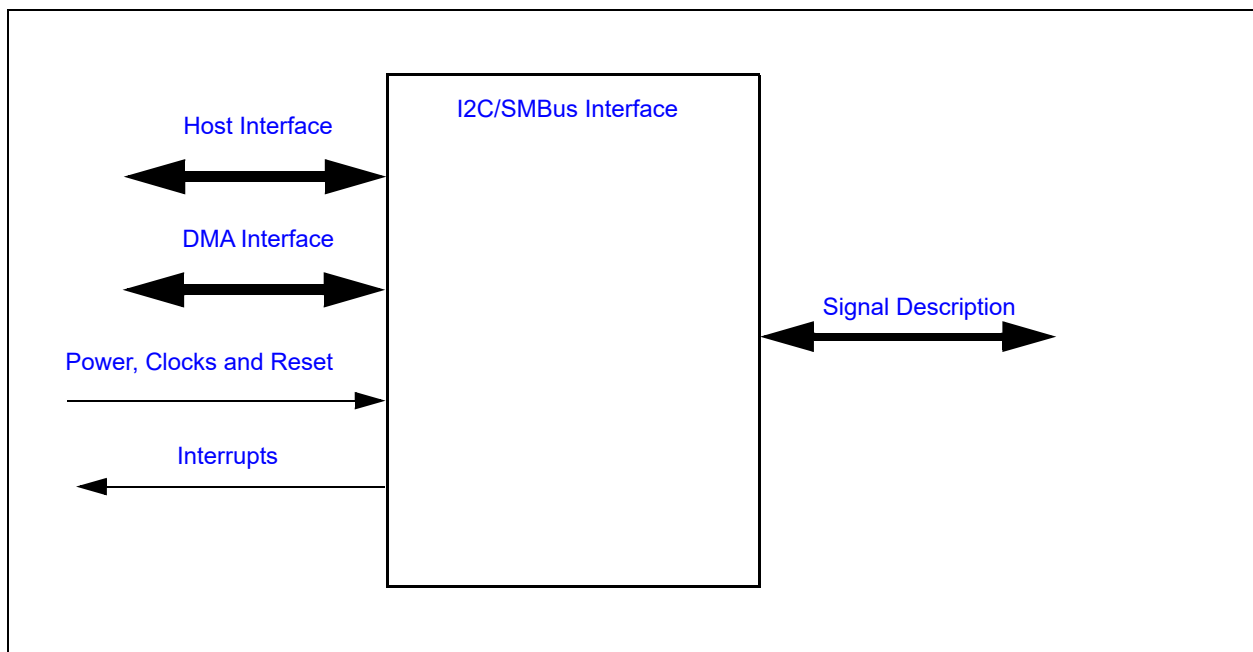

11.5 Signal Description

see the Pin Configuration section for a description of the SMB-I2C pin configuration.

11.6 Host Interface

The registers defined for the [I2C/SMBus Interface](#) are accessible by the various hosts as indicated in [Section 3.2, "Block Overview and Base Addresses"](#).

MEC1725

11.7 DMA Interface

This block is designed to communicate with the Internal DMA Controller. This feature is defined in the SMB-I2C Controller Core Interface specification (See Ref [1]).

Note: For a description of the Internal DMA Controller implemented in this design see [Section 7.0, "Internal DMA Controller"](#).

11.8 Power, Clocks and Reset

This section defines the Power, Clock, and Reset parameters of the block.

11.8.1 POWER DOMAINS

Name	Description
VTR_CORE	This power well sources all of the registers and logic in this block, except where noted.

11.8.2 CLOCK INPUTS

Name	Description
16MHz	This is the clock signal drives the SMB-I2C Controller core. The core also uses this clock to generate the SMB-I2C_CLK on the pin interface. It is derived from the main system clock

11.8.3 RESETS

Name	Description
RESET_SYS	This reset signal resets all of the registers and logic in the SMB-I2C Controller core.

11.9 Interrupts

Source	Description
SMB-I2C	I ² C Activity Interrupt Event
SMB-I2C_WAKE	This interrupt event is triggered when an SMB/I2C Master initiates a transaction by issuing a START bit (a high-to-low transition on the SDA line while the SCL line is high) on the bus currently connected to the SMB-I2C Controller. The EC interrupt handler for this event only needs to clear the interrupt SOURCE bit and return; if the transaction results in an action that requires EC processing, that action will trigger the SMB-I2C interrupt event.

11.10 Low Power Modes

The SMB-I2C Controller may be put into a low power state by the chip's Power, Clocks, and Reset (PCR) circuitry.

11.11 Description

11.11.1 SMB-I2C CONTROLLER CORE

The SMB-I2C Controller behavior is defined in the SMB-I2C Controller Core Interface specification (See Ref [1]).

11.11.2 PHYSICAL INTERFACE

The Physical Interface for the SMB-I2C Controller core is configurable for up to 106 ports. Each I2C_WAKE Controller can be connected to any of the ports defined in [Table 11-1, "SMB-I2C Port Selection"](#). The *PORT_SEL [3:0]* bit field in each controller independently sets the port for the controller. The default for each field is Fh, Reserved, which means that the SMB-I2C Controller is not connected to a port.

An I²C port should be connected to a single controller. An attempt to configure the *PORT_SEL [3:0]* bits in one controller to a value already assigned to another controller may result in unexpected results.

The port signal-function names and pin numbers are defined in Pin Configuration section. The I²C port selection is made using the *PORT_SEL [3:0]* bits in the *Configuration Register* as described in Ref [1]. In the Pin section, the SDA (Data) pins are listed as *asi2Cxx_SDA* and the SCL (Clock) pins are listed as *I2Cxx_SCL*, where *xx* represents the port number 00 through 15. The CPU-voltage-level port *SB_TSI* is also listed in the pin section with the *SD-TSI_DAT* and *SD-TSI_CLK*.

For I²C port signal functions that are alternate functions of GPIO pins, the buffer type for these pins must be configured as open-drain outputs when the port is selected as an I²C port.

For more information regarding the SMB-I2C Controller core see [Section 2.2, "Physical Interface"](#) in Ref[1].

TABLE 11-1: SMB-I2C PORT SELECTION

PORT_SEL[3:0]				Port
3	2	1	0	
0	0	0	0	I2C00
0	0	0	1	I2C01
0	0	1	0	I2C02
0	0	1	1	I2C03
0	1	0	0	I2C04
0	1	0	1	I2C05
0	1	1	0	I2C06
0	1	1	1	I2C07
1	0	0	0	I2C08
1	0	0	1	I2C09
1	0	1	0	I2C10
1	0	1	1	I2C11
1	1	0	0	I2C12
1	1	0	1	I2C13
1	1	1	0	I2C14
1	1	1	1	I2C15

Note: Refer to [Section 2.4.10](#) for the pin mapping

FIGURE 11-2: SMB-I2C PORT CONNECTIVITY

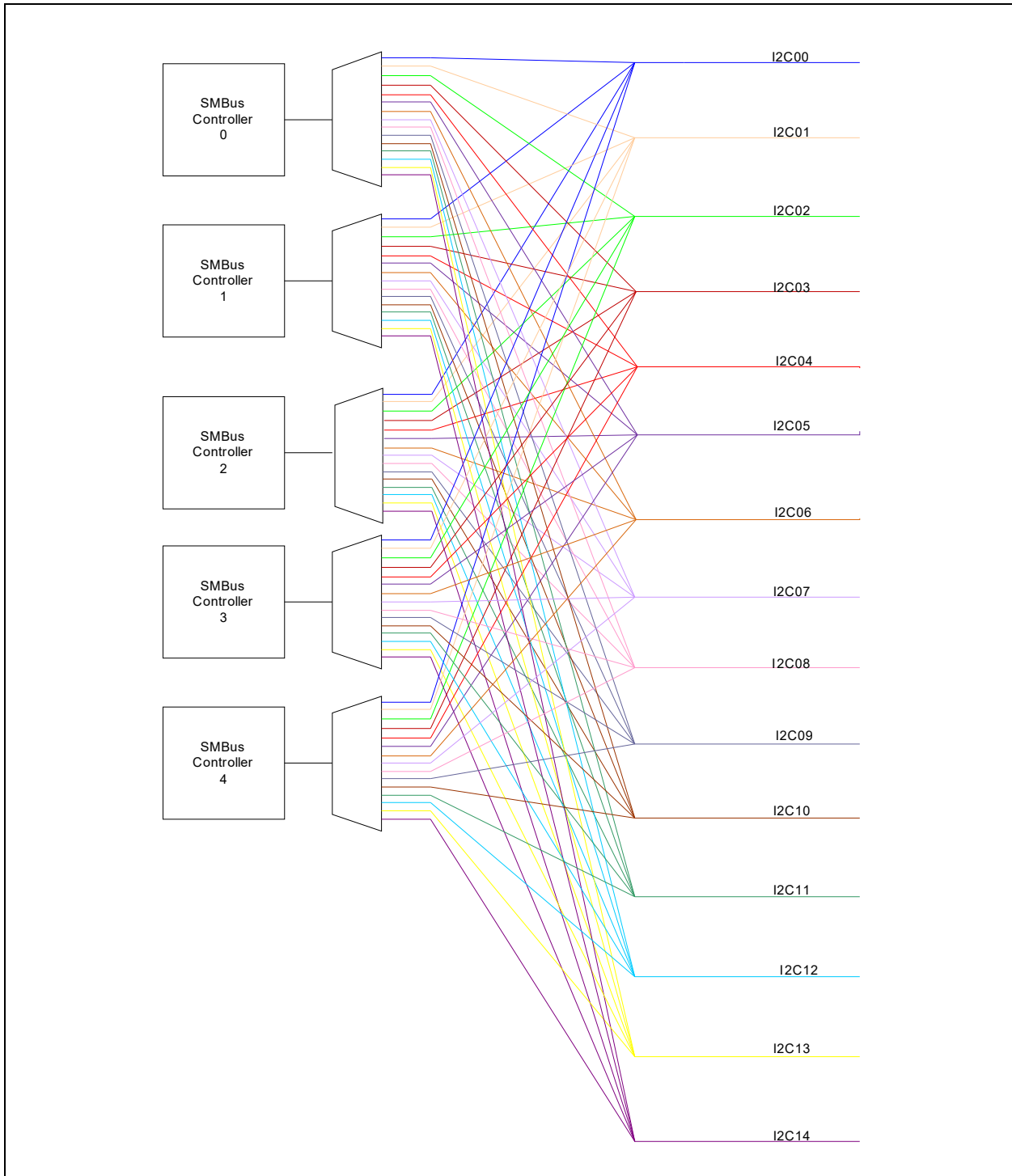

11.12 EC Registers

Registers for this block are shown in the following summary table. Addresses for each register are determined by adding the offset to the Base Address for each instance of the SMB-I2C Controller Block in the Block Overview and Base Address Table in [Section 3.0, "Device Inventory"](#).

Registers for the SMB-I2C Controllers are listed in Reference[1].

11.13 Application Note

Port number and Filter Enable (FEN) should be written before setting the enable bit in the Configuration register. Though a single write can perform the enable as well as configuration simultaneously, it may lead the controller to treat the bus as busy due to noise incurred in configuring the port and Filtering.

For example:

Enable the block after the ports have been set-up.

Config write 0xc0000101 //Set up the port number and Filter enable

Config write 0xc0000501 // Enable the I2C operation

MEC1725

12.0 8042 EMULATED KEYBOARD CONTROLLER

12.1 Introduction

The MEC1725 keyboard controller uses the EC to produce a superset of the features provided by the industry-standard 8042 keyboard controller. The [8042 Emulated Keyboard Controller](#) is a Host/EC Message Interface with hardware assists to emulate 8042 behavior and provide Legacy GATEA20 support.

12.2 Interface

This block is designed to be accessed externally via the pin interface and internally via a registered host interface.

FIGURE 12-1: I/O DIAGRAM OF BLOCK

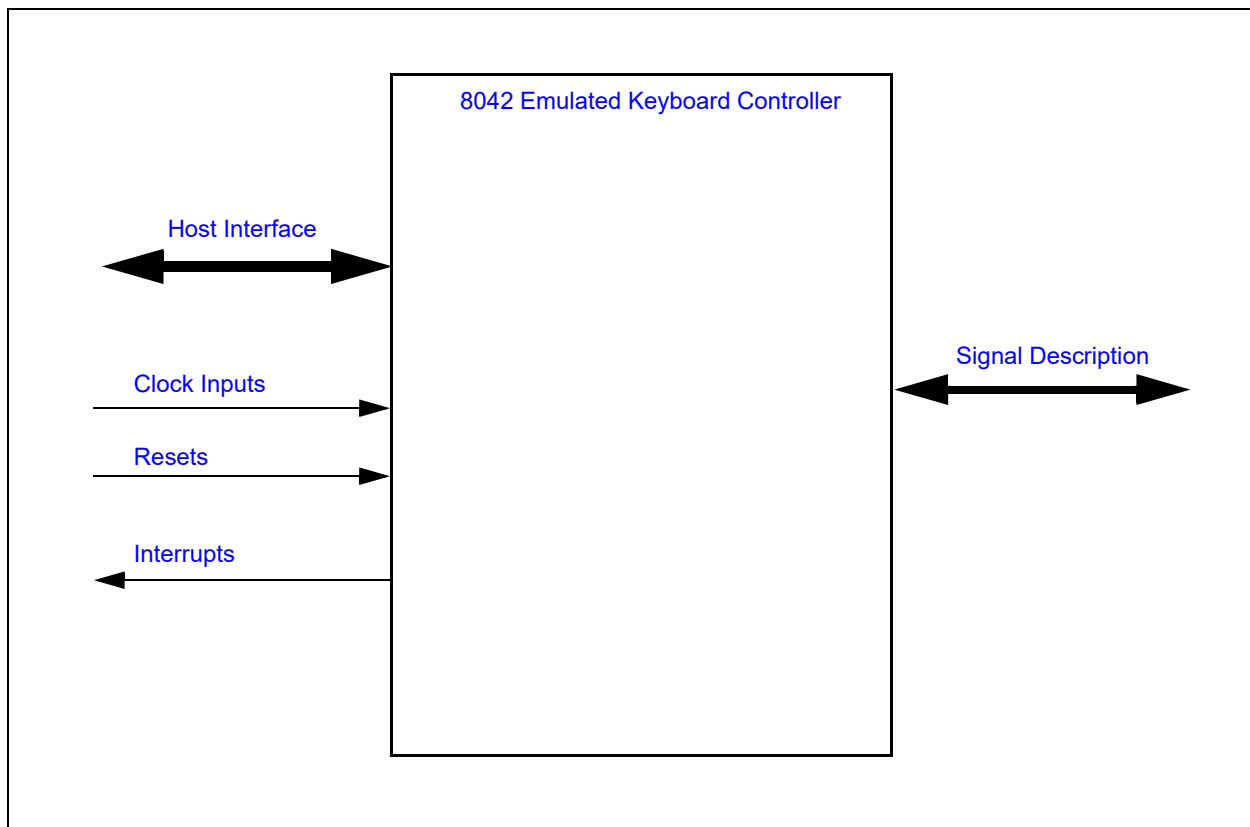

12.3 Signal Description

TABLE 12-1: SIGNAL DESCRIPTION TABLE

Name	Direction	Description
KBRST	Output	Keyboard Reset, routed to pin
A20M	Output	Keyboard gate A20 output pin

12.4 Host Interface

The registers defined for 8042 interface is accessed by the various hosts as indicated in [Section 3.2, "Block Overview and Base Addresses"](#).

12.5 Power, Clocks and Reset

This section defines the Power, Clock, and Reset parameters of the block.

12.5.1 POWER DOMAINS

TABLE 12-2: POWER SOURCES

Name	Description
VTR_CORE	This Power Well is used to power the registers and logic in this block.

12.5.2 CLOCK INPUTS

TABLE 12-3: CLOCK INPUTS

Name	Description
1MHz	Clock used for the counter in the CPU_RESET circuitry.

12.5.3 RESETS

TABLE 12-4: RESET SIGNALS

Name	Description
RESET_SYS	This reset is asserted when VTR_CORE is applied.
RESET_VCC	This signal is asserted when the main power rail is off or held off by the PWR_INV bit in the Power Reset Control Register.
RESET_HOST	This signal is asserted when the main power rail is off or held off by the PWR_INV bit in the Power Reset Control Register, and also when the Host resets the Host-EC link via PCI_RESET# or PLTRST#.

12.6 Interrupts

This section defines the Interrupt Sources generated from this block.

TABLE 12-5: SYSTEM INTERRUPTS

Source	Description
KIRQ	This interrupt source for the SIRQ logic, representing a Keyboard interrupt, is generated when the PCOBF status bit is '1'.
MIRQ	This interrupt source for the SIRQ logic, representing a Mouse interrupt, is generated when the AUXOBF status bit is '1'.

MEC1725

TABLE 12-6: EC INTERRUPTS

Source	Description
IBF	Interrupt generated by the host writing either data or command to the data register. This interrupt is asserted when the input buffer becomes not empty (i.e., when the IBF flag goes to 1).
OBE	Interrupt generated by the host reading either data or aux data from the data register. This interrupt is asserted when the output buffer becomes empty (i.e., when the OBF flag goes to 0).

12.7 Low Power Modes

The 8042 Interface may be put into a low power state by the chip's Power, Clocks, and Reset (PCR) circuitry.

12.8 Description

12.8.1 BLOCK DIAGRAM

FIGURE 12-2: BLOCK DIAGRAM OF 8042 Emulated Keyboard Controller

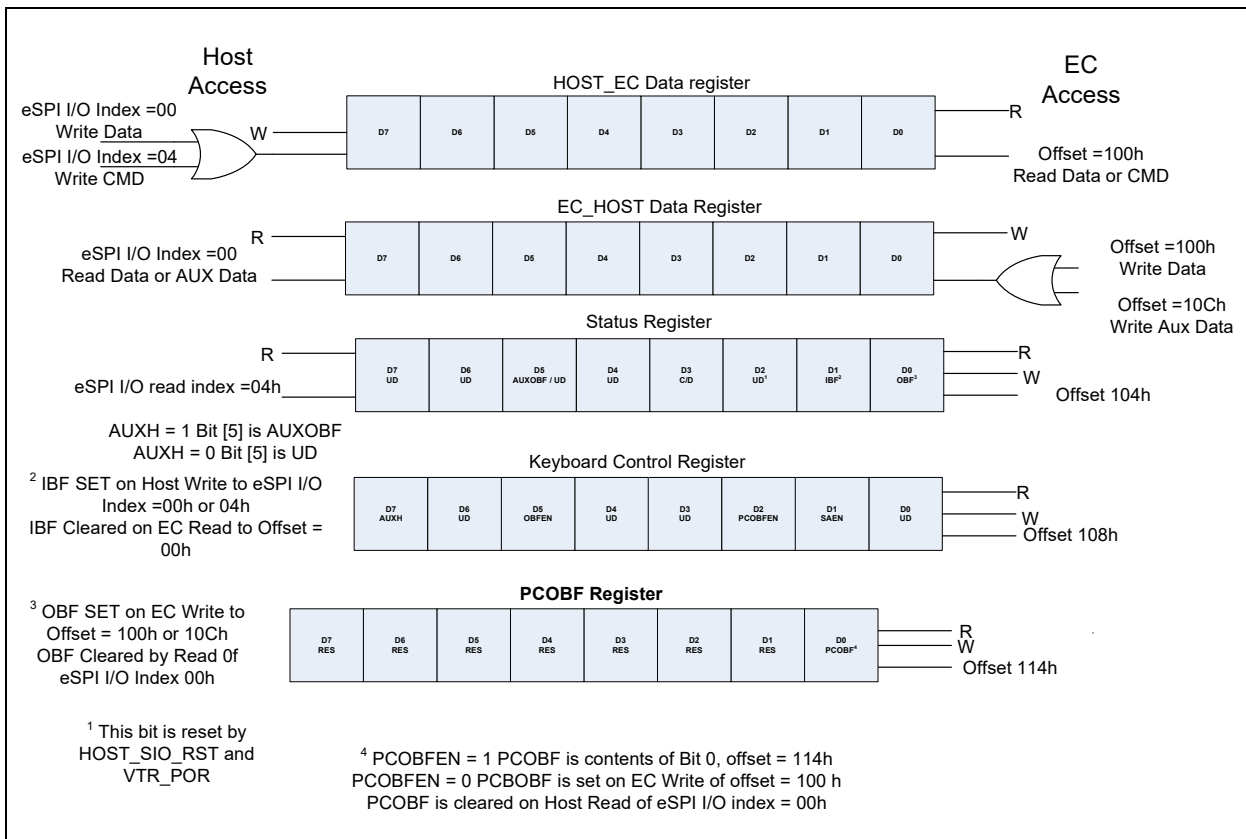

12.9 EC-to-Host Keyboard Communication

The EC can write to the **EC_HOST Data / AUX Data Register** by writing to the **HOST2EC Data Register** at EC-Only offset 0h or the **EC AUX Data Register** at EC-Only offset Ch. A write to either of these addresses automatically sets bit 0 (**OBF**) in the Status register. A write to the **HOST2EC Data Register** may also set **PCOBF**. A write to the **EC AUX Data Register** may also set **AUXOBF**.

12.9.1 PCOBF DESCRIPTION

If enabled by the bit OBFEN, the bit PCOBF is gated onto KIRQ. The KIRQ signal is a system interrupt which signifies that the EC has written to the [HOST2EC Data Register](#) (EC-Only offset 0h). On power-up, PCOBF is reset to 0. PCOBF will normally reflect the status of writes to HOST2EC register, if [PCOBFEN](#) is "0". PCOBF is cleared by hardware on a HOST read of the [EC_HOST Data / AUX Data Register](#).

KIRQ is normally selected as IRQ1 for keyboard support.

Additional flexibility has been added which allows firmware to directly control the PCOBF output signal, independent of data transfers to the host-interface data output register. This feature allows the MEC1725 to be operated via the host "polled" mode. Firmware control is active when PCOBFEN is '1'. Firmware sets PCOBF high by writing a "1" to the [PCOBF](#) field of the [PCOBF Register](#). Firmware must also clear PCOBF by writing a "0" to the [PCOBF](#) field.

The PCOBF register is also readable; the value read back on bit 0 of the register always reflects the present value of the PCOBF output. If PCOBFEN = 1, then this value reflects the output of the firmware latch in the [PCOBF Register](#). If PCOBFEN = 0, then the value read back reflects the in-process status of write cycles to the [HOST2EC Data Register](#) (i.e., if the value read back is high, the host interface output data register has just been written to). If OBFEN=0, then KIRQ is driven inactive (low).

12.9.2 AUXOBF DESCRIPTION

If enabled by the bit OBFEN, the bit AUXOBF is multiplexed onto MIRQ. The AUXOBF/MIRQ signal is a system interrupt which signifies that the EC has written to the [EC_HOST Data / AUX Data Register](#). On power-up, after [RESET_SYS](#), AUXOBF is reset to 0. AUXOBF will normally reflect the status of writes to EC [EC AUX Data Register](#) (EC-Only offset Ch). AUXOBF is cleared by hardware on a read of the Host Data Register. If OBFEN=0, then MIRQ is driven inactive (low).

MIRQ is normally selected as IRQ15 for mouse support.

Firmware can also directly control the AUXOBF output signal, similar to the mechanism it can use to control PCOBF. Firmware control is active when [AUXH](#) is '0'. Firmware sets AUXOBF high by writing a "1" to the [AUXOBF](#) field of the [EC Keyboard Status Register](#). Firmware must also clear AUXOBF by writing a "0" to the [AUXOBF](#) field.

TABLE 12-7: OBFEN AND PCOBFEN EFFECTS ON KIRQ

OBFEN	PCOBFEN	
0	X	KIRQ is inactive and driven low
1	0	KIRQ = PCOBF (status of writes to HOST2EC Data Register)
1	1	KIRQ = PCOBF (status of writes to PCOBF Register)

TABLE 12-8: OBFEN AND AUXH EFFECTS ON MIRQ

OBFEN	AUXH	
0	X	MIRQ is inactive and driven low
1	0	MIRQ = AUXOBF (status of writes to EC AUX Data Register)
1	1	MIRQ = AUXOBF (status of writes to AUXOBF in EC Keyboard Status Register)

12.10 Legacy Port92/GATEA20 Support

The MEC1725 supports I/O writes to port HOST I/O address 92h as a quick alternate mechanism for generating a CPU_RESET pulse or controlling the state of GATEA20. The Port92/GateA20 logic has a separate Logical Device Number and Base Address register (see [Section 12.15, "Legacy Port92/GATEA20 Configuration Registers"](#) and [Section 12.16, "Legacy Port92/GATEA20 Runtime Registers"](#)). The Base Address Register for the Port92/GateA20 Logical Device has only one writable bit, the Valid Bit, since the only I/O accessible Register has a fixed address.

MEC1725

The [Port 92 Register](#) resides at HOST I/O address 92h and is used to support the alternate reset (ALT_RST#) and alternate GATEA20 (ALT_A20) functions. This register defaults to 00h on assertion of [RESET_VCC](#).

Setting the Port92 Enable bit ([Port 92 Enable Register](#)) enables the Port92h Register. When Port92 is disabled, by clearing the Port92 Enable bit, then access to this register is completely disabled (I/O writes to host 92h are ignored and I/O reads float the system data bus SD[7:0]).

12.10.1 GATE A20 SPEEDUP

The MEC1725 contains on-chip logic support for the GATEA20 hardware speed-up feature. GATEA20 is part of the control required to mask address line A20 to emulate 8086 addressing.

In addition to the ability for the host to control the GATEA20 output signal directly, a configuration bit called [SAEN](#) in the [Keyboard Control Register](#) is provided; when set, SAEN allows firmware to control the GATEA20 output. When SAEN is set, a 1 bit register ([GATEA20 Control Register](#)) controls the GATEA20 output.

Host control and firmware control of GATEA20 affect two separate register elements. Read back of GATEA20 through the use of EC OFFSET 100h reflects the present state of the GATEA20 output signal: if SAEN is set, the value read back corresponds to the last firmware-initiated control of GATEA20; if SAEN is reset, the value read back corresponds to the last host-initiated control of GATEA20.

Host control of the GATEA20 output is provided by the hardware interpretation of the “GATEA20 sequence” (see [Table 12-9, "GATEA20 Command/Data Sequence Examples"](#)). The foregoing description assumes that the SAEN configuration bit is reset.

When the MEC1725 receives a “D1” command followed by data (via the host interface), the on-chip hardware copies the value of data bit 1 in the received data field to the GATEA20 host latch. At no time during this host-interface transaction will [PCOBF](#) or the [IBF](#) flag (bit 1) in the [EC Keyboard Status Register](#) be activated; for example, this host control of GATEA20 is transparent to firmware, with no consequent degradation of overall system performance. [Table 12-9](#) details the possible GATEA20 sequences and the MEC1725 responses.

An additional level of control flexibility is offered via a memory-mapped synchronous set and reset capability. Any data written to the [SETGA20L Register](#) causes the GATEA20 host latch to be set; any data written to the [RSTGA20L Register](#) causes it to be reset. This control mechanism should be used with caution. It was added to augment the “normal” control flow as described above, not to replace it. Since the host and the firmware have asynchronous control capability of the host latch via this mechanism, a potential conflict could arise. Therefore, after using the SETGA20L and RSTGA20L registers, firmware should read back the GATEA20 status via the GATEA20 Control Register (with SAEN = 0) to confirm the actual GATEA20 response.

TABLE 12-9: GATEA20 COMMAND/DATA SEQUENCE EXAMPLES

Data Byte	R/W	D[0:7]	IBF Flag	GATEA20	Comments
1 0 1	W W W	D1 DF FF	0 0 0	Q 1 1	GATEA20 Turn-on Sequence
1 0 1	W W W	D1 DD FF	0 0 0	Q 0 0	GATEA20 Turn-off Sequence
1 1 0 1	W W W W	D1 D1 DF FF	0 0 0 0	Q Q 1 1	GATEA20 Turn-on Sequence(*)
1 1 0 1	W W W W	D1 D1 DD FF	0 0 0 0	Q Q 0 0	GATEA20 Turn-off Sequence(*)

TABLE 12-9: GATEA20 COMMAND/DATA SEQUENCE EXAMPLES (CONTINUED)

Data Byte	R/W	D[0:7]	IBF Flag	GATEA20	Comments
1	W	D1	0	Q	Invalid Sequence
1	W	XX**	1	Q	
1	W	FF	1	Q	

Note: The following notes apply:

- All examples assume that the SAEN configuration bit is 0.
- “Q” indicates the bit remains set at the previous state.
- *Not a standard sequence.
- **XX = Anything except D1.
- If multiple data bytes, set IBF and wait at state 0. Let the software know something unusual happened.
- For data bytes, only D[1] is used; all other bits are don't care.
- Host Commands (FF, FE, and D1) do not cause IBF. The method of blocking IBF in [Figure 12-4](#) is the nIOW not being asserted when FF, FE, and D1 Host commands are written”.

MEC1725

The hardware GATEA20 state machine returns to state S1 from state S2 when CMD = D1, as shown in the following figures:.

FIGURE 12-3: GATEA20 STATE MACHINE

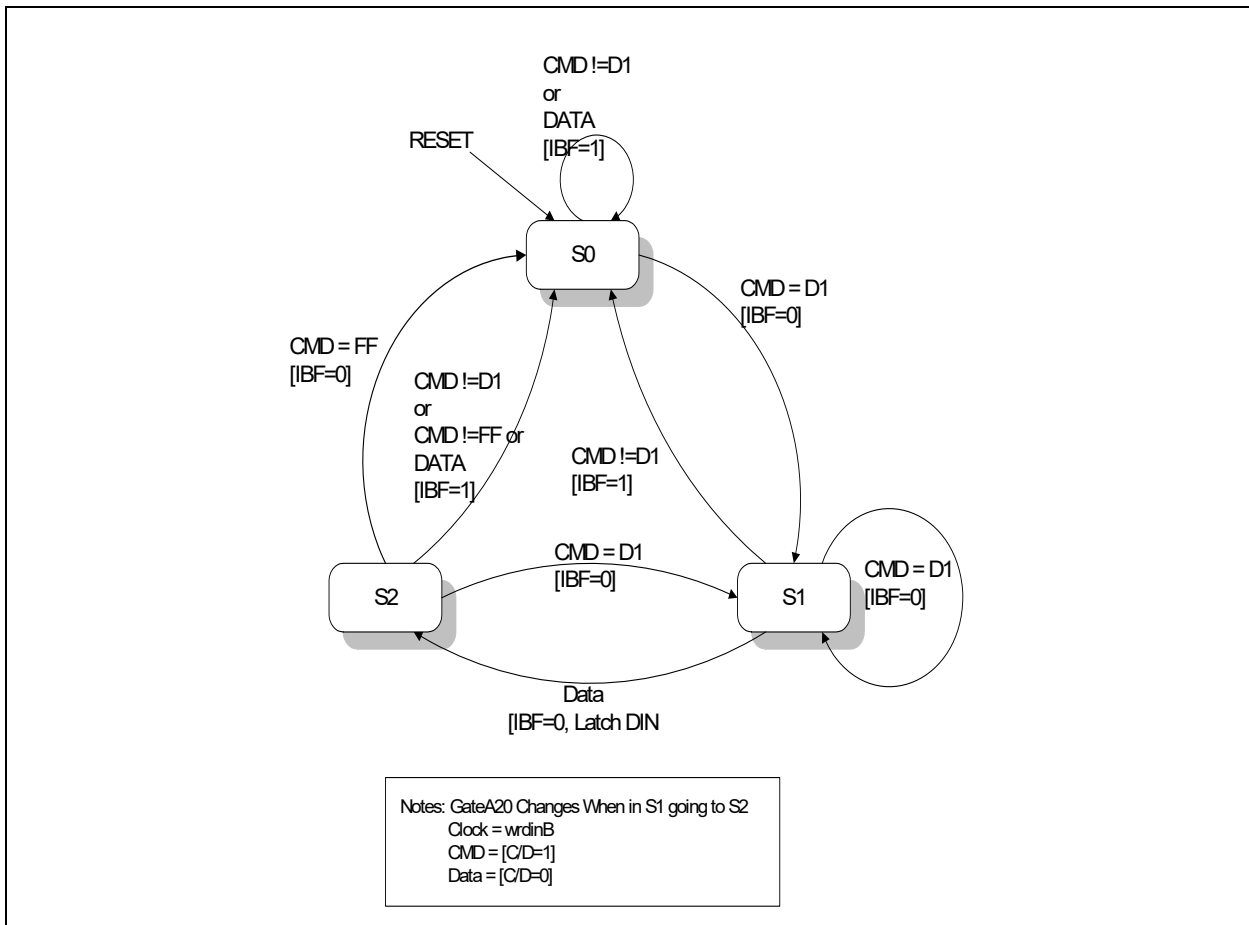
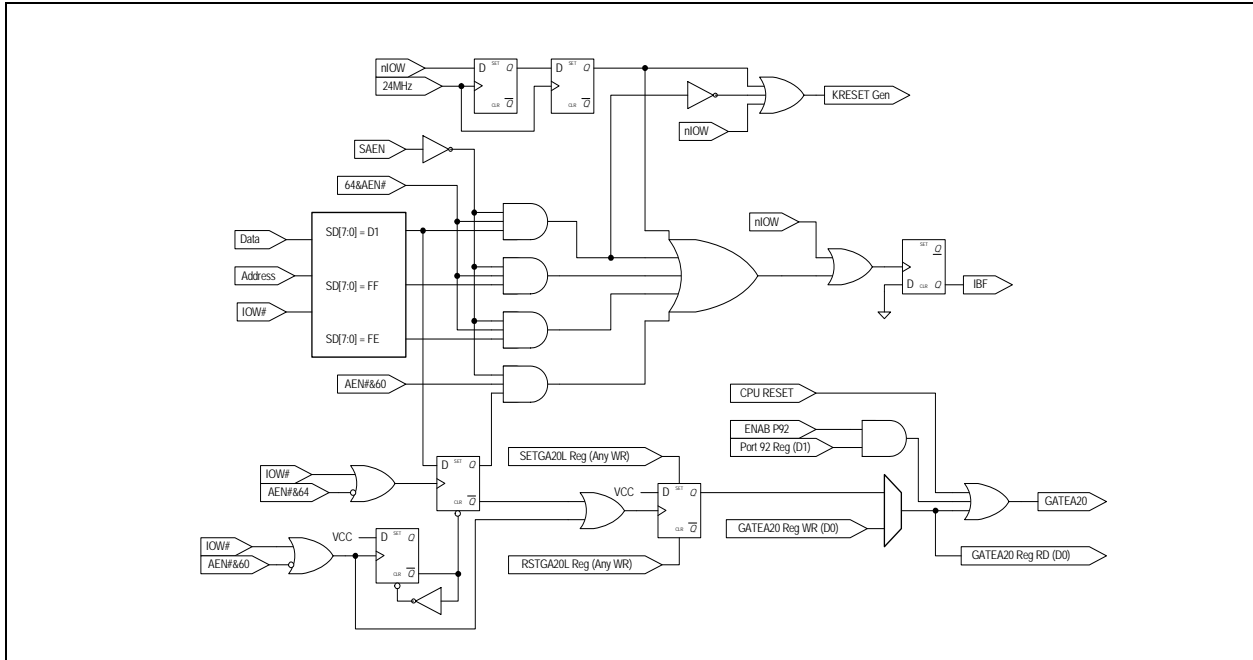

FIGURE 12-4: GATEA20 IMPLEMENTATION DIAGRAM



12.10.2 CPU_RESET HARDWARE SPEED-UP

The [ALT_CPU_RESET](#) bit generates, under program control, the [ALT_RST#](#) signal, which provides an alternate, means to drive the MEC1725 [CPU_RESET](#) pin which in turn is used to reset the Host CPU. The [ALT_RST#](#) signal is internally Nanded together with the [KBDRESET#](#) pulse from the [KRESET](#) Speed up logic to provide an alternate software means of resetting the host CPU.

Before another [ALT_RST#](#) pulse can be generated, [ALT_CPU_RESET](#) must be cleared to '0' either by an [RESET_VCC](#) or by a write to the [Port 92 Register](#) with bit 0 = '0'. An [ALT_RST#](#) pulse is not generated in the event that the [ALT_CPU_RESET](#) bit is cleared and set before the prior [ALT_RST#](#) pulse has completed.

If the 8042EM Sleep Enable is asserted, or the 8042 EM [ACTIVATE](#) bit is de-asserted, the 1MHz clocks source is disabled.

MEC1725

FIGURE 12-5: CPU_RESET IMPLEMENTATION DIAGRAM

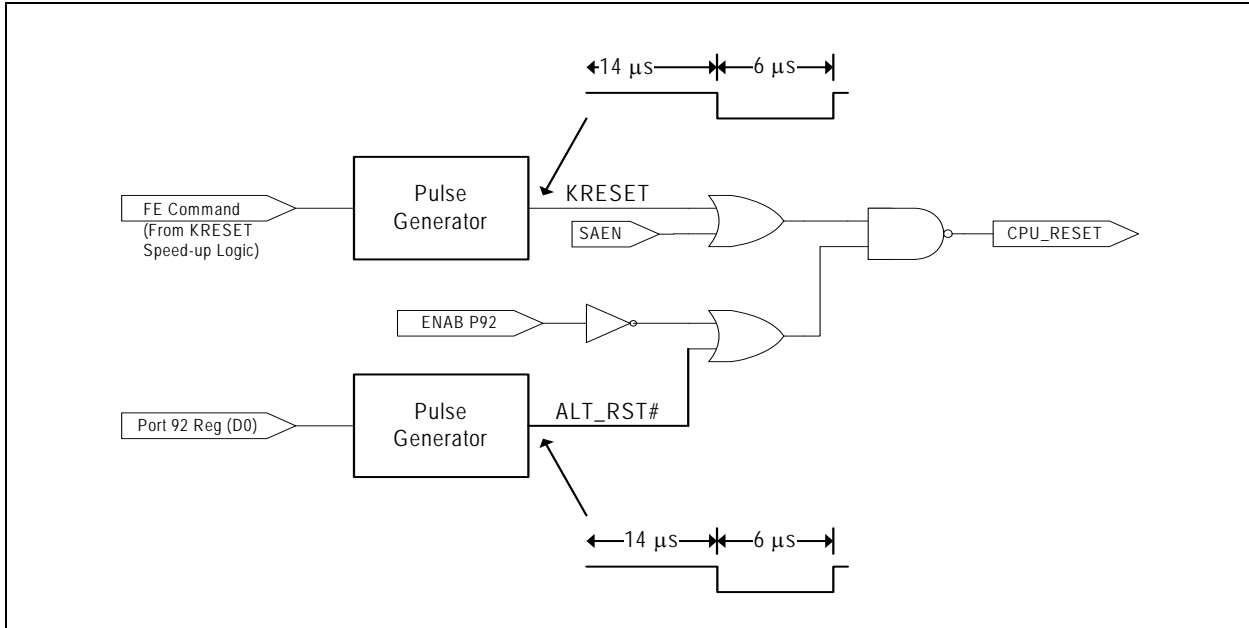

12.11 Instance Description

There are two blocks defined in this chapter: Emulated 8042 Interface and the Port 92-Legacy Interface. The MEC1725 has one instance of each block.

12.12 Configuration Registers

Configuration Registers for an instance of the [8042 Emulated Keyboard Controller](#) are listed in the following table. Host access to Configuration Registers is through the Configuration Port using the Logical Device Number of the [8042 Emulated Keyboard Controller](#) instance and the Index shown in the “Host Index” column of the table. The EC can access Configuration Registers directly. The EC address for each register is formed by adding the Base Address for each instance of the [8042 Emulated Keyboard Controller](#) shown in the Block Overview and Base Address Table in [Section 3.0, “Device Inventory”](#) to the offset shown in the “EC Offset” column.

TABLE 12-10: CONFIGURATION REGISTER SUMMARY

EC Offset	Host Index	Register Name
330h	30h	Activate Register

12.12.1 ACTIVATE REGISTER

Offset	30h			
Bits	Description	Type	Default	Reset Event
7:1	Reserved	RES	-	-
0	ACTIVATE 1=The 8042 Interface is powered and functional. 0=The 8042 Interface is powered down and inactive.	R/W	0b	RESET_VCC

12.13 Runtime Registers

The registers listed in the Runtime Register Summary table are for a single instance of the [8042 Emulated Keyboard Controller](#). Host access for each register listed in this table is defined as an offset in the Host address space to the Block's Base Address, as defined by the instance's Base Address Register.

The EC address for each register is formed by adding the Base Address for the [8042 Emulated Keyboard Controller](#) shown in the Block Overview and Base Address Table in [Section 3.0, "Device Inventory"](#) to the offset shown in the "Offset" column.

TABLE 12-11: RUNTIME REGISTER SUMMARY

Offset	Register Name
0h/04h	HOST_EC Data / CMD Register
0h	EC_HOST Data / AUX Data Register
4h	Keyboard Status Read Register

12.13.1 HOST_EC DATA / CMD REGISTER

Offset	0h			
Bits	Description	Type	Default	Reset Event
7:0	<p>WRITE_DATA</p> <p>This 8-bit register is write-only. When written, the C/D bit in the Keyboard Status Read Register is cleared to '0', signifying data, and the IBF in the same register is set to '1'.</p> <p>When the Runtime Register at offset 0h is read by the Host, it functions as the EC_HOST Data / AUX Data Register.</p>	W	0h	RESET_SYS

Offset	04h			
Bits	Description	Type	Default	Reset Event
7:0	<p>WRITE_CMD</p> <p>.This 8-bit register is write-only and is an alias of the register at offset 0h. When written, the C/D bit in the Keyboard Status Read Register is set to '1', signifying a command, and the IBF in the same register is set to '1'.</p> <p>When the Runtime Register at offset 4h is read by the Host, it functions as the Keyboard Status Read Register.</p>	W	0h	RESET_SYS

MEC1725

12.13.2 EC_HOST DATA / AUX DATA REGISTER

Offset	0h			
Bits	Description	Type	Default	Reset Event
7:0	READ_DATA This 8-bit register is read-only. When read by the Host, the PCOBF and/or AUXOBF interrupts are cleared and the OBF flag in the status register is cleared.	R	0h	RESET_SYS

12.13.3 KEYBOARD STATUS READ REGISTER

This register is a read-only alias of the [EC Keyboard Status Register](#).

Offset	04h			
Bits	Description	Type	Default	Reset Event
7:6	UD2 User-defined data. Readable and writable by the EC when written by the EC at its EC-only alias.	R	0h	RESET_SYS
5	AUXOBF Auxiliary Output Buffer Full. This bit is set to "1" whenever the EC writes the EC AUX Data Register . This flag is reset to "0" whenever the EC writes the EC Data Register .	R	0h	RESET_SYS
4	UD1 User-defined data. Readable and writable by the EC when written by the EC at its EC-only alias.	R	0h	RESET_SYS
3	C/D Command Data. This bit specifies whether the input data register contains data or a command ("0" = data, "1" = command). During a Host command write operation (when the Host writes the HOST_EC Data / CMD Register at offset 04h), this bit is set to "1". During a Host data write operation (when the Host writes the HOST_EC Data / CMD Register at offset 0h), this bit is set to "0".	R	0h	RESET_SYS
2	UD0 User-defined data. Readable and writable by the EC when written by the EC at its EC-only alias.	R	0h	RESET_HOST
1	IBF Input Buffer Full. This bit is set to "1" whenever the Host writes data or a command into the HOST_EC Data / CMD Register . When this bit is set, the EC's IBF interrupt is asserted, if enabled. When the EC reads the HOST_EC Data / CMD Register , this bit is automatically reset and the interrupt is cleared. This bit is not reset on RESET_VCC . To clear this bit, firmware must read the HOST2EC Data Register in the EC-Only address space.	R	0h	RESET_SYS

Offset	04h			
Bits	Description	Type	Default	Reset Event
0	<p>OBF</p> <p>Output Buffer Full. This bit is set when the EC writes a byte of Data or AUX Data into the EC_HOST Data / AUX Data Register. When the Host reads the HOST_EC Data / CMD Register, this bit is automatically cleared by hardware and an OBE interrupt is generated.</p> <p>This bit is not reset on RESET_VCC. To clear this bit, firmware must read the HOST2EC Data Register in the EC-Only address space.</p>	R	0h	RESET_SYS

12.14 EC Registers

Registers for this block are shown in the following summary table. Addresses for each register are determined by adding the offset to the Base Address for each instance of the [8042 Emulated Keyboard Controller](#) Block in the Block Overview and Base Address Table in [Section 3.0, "Device Inventory"](#).

TABLE 12-12: EC-ONLY REGISTER SUMMARY

Offset	Register Name
100h	HOST2EC Data Register
100h	EC Data Register
104h	EC Keyboard Status Register
108h	Keyboard Control Register
10Ch	EC AUX Data Register
114h	PCOBF Register

12.14.1 HOST2EC DATA REGISTER

Offset	100h			
Bits	Description	Type	Default	Reset Event
7:0	<p>HOST2EC_DATA</p> <p>This register is an alias of the HOST_EC Data / CMD Register. When read at the EC-Only offset of 0h, it returns the data written by the Host to either Runtime Register offset 0h or Runtime Register offset 04h.</p>	R	0h	RESET_SYS

12.14.2 EC DATA REGISTER

Offset	100h			
Bits	Description	Type	Default	Reset Event
7:0	EC_DATA	W	0h	RESET_SYS

MEC1725

12.14.3 EC KEYBOARD STATUS REGISTER

This register is an alias of the [Keyboard Status Read Register](#). The fields [C/D](#), [IBF](#), and [OBF](#) remain read-only.

Offset	104h			
Bits	Description	Type	Default	Reset Event
7:6	UD2 User-defined data. Readable and writable by the EC.	R/W	0h	RESET_SYS
5	AUXOBF Auxiliary Output Buffer Full. This bit is set to '1' whenever the EC writes the EC AUX Data Register . This flag is reset to '0' whenever the EC writes the EC Data Register .	R/W	0h	RESET_SYS
4	UD1 User-defined data. Readable and writable by the EC when written by the EC at its EC-only alias.	R/W	0h	RESET_SYS
3	C/D Command Data. This bit specifies whether the input data register contains data or a command. During a Host command write operation (when the Host writes the HOST_EC Data / CMD Register at offset 04h), this bit is set to '1'. During a Host data write operation (when the Host writes the HOST_EC Data / CMD Register at offset 0h), this bit is set to '0'. 1=Command 0=Data	R	0h	RESET_SYS
2	UD0 User-defined data. Readable and writable by the EC when written by the EC at its EC-only alias.	R/W	0h	RESET_HOST
1	IBF Input Buffer Full. This bit is set to "1" whenever the Host writes data or a command into the HOST_EC Data / CMD Register . When this bit is set, the EC's IBF interrupt is asserted, if enabled. When the EC reads the Data/CMD Register, this bit is automatically reset and the interrupt is cleared. This bit is not reset on RESET_VCC . To clear this bit, firmware must read the HOST2EC Data Register in the EC-Only address space.	R	0h	RESET_SYS
0	OBF Output Buffer Full. This bit is set when the EC writes a byte of Data or AUX Data into the EC_HOST Data / AUX Data Register . When the Host reads the HOST_EC Data / CMD Register , this bit is automatically cleared by hardware and a OBE interrupt is generated. This bit is not reset on RESET_VCC . To clear this bit, firmware must read the HOST2EC Data Register in the EC-Only address space.	R	0h	RESET_SYS

12.14.4 KEYBOARD CONTROL REGISTER

Offset	108h			
Bits	Description	Type	Default	Reset Event
7	<p>AUXH AUX in Hardware.</p> <p>1=AUXOBF of the Keyboard Status Read Register is set in hardware by a write to the EC AUX Data Register 0=AUXOBF is not modified in hardware, but can be read and written by the EC using the EC-Only alias of the EC Keyboard Status Register</p>	R/W	0h	RESET_SYS
6	<p>UD5 User-defined data. Readable and writable by the EC when written by the EC at its EC-only alias.</p>	R/W	0h	RESET_SYS
5	<p>OBFEN When this bit is '1', the system interrupt signal KIRQ is driven by the bit PCOBF and MIRQ is driven by AUXOBF. When this bit is '0', KIRQ and MIRQ are driven low. This bit must not be changed when OBF of the status register is equal to '1'.</p>	R/W	0h	RESET_SYS
4:3	<p>UD4 User-defined data. Readable and writable by the EC when written by the EC at its EC-only alias.</p>	R/W	0h	RESET_SYS
2	<p>PCOBFEN 1=reflects the value written to the PCOBF Register 0=PCOBF reflects the status of writes to the EC Data Register</p>	R/W	0h	RESET_SYS
1	<p>SAEN Software-assist enable.</p> <p>1=This bit allows control of the GATEA20 signal via firmware 0=GATEA20 corresponds to either the last Host-initiated control of GATEA20 or the firmware write to the Keyboard Control Register or the EC AUX Data Register.</p>	R/W	0h	RESET_SYS
0	<p>UD3 User-defined data. Readable and writable by the EC when written by the EC at its EC-only alias.</p>	R/W	0h	RESET_SYS

MEC1725

12.14.5 EC AUX DATA REGISTER

Offset	10Ch			
Bits	Description	Type	Default	Reset Event
7:0	<p>EC_AUX_DATA</p> <p>This 8-bit register is write-only. When written, the C/D in the Keyboard Status Read Register is cleared to '0', signifying data, and the IBF in the same register is set to '1'.</p> <p>When the Runtime Register at offset 0h is read by the Host, it functions as the EC_HOST Data / AUX Data Register.</p>	W	0h	RESET_SYS

12.14.6 PCOBF REGISTER

Offset	114h			
Bits	Description	Type	Default	Reset Event
7:1	Reserved	RES	-	-
0	<p>PCOBF</p> <p>For a description of this bit, see Section 12.9.1, "PCOBF Description".</p>	R/W	0h	RESET_SYS

12.15 Legacy Port92/GATEA20 Configuration Registers

Configuration Registers for an instance of the Port92-Legacy block are listed in the following table. Host access to Configuration Registers is through the Configuration Port using the Logical Device Number of the Port 92 instance and the Index shown in the "Host Index" column of the table. The EC can access Configuration Registers directly. The EC address for each register is formed by adding the Base Address for each instance of the Port 92 block shown in the Block Overview and Base Address Table in [Section 3.0, "Device Inventory"](#) to the offset shown in the "EC Offset" column.

TABLE 12-13: CONFIGURATION REGISTER SUMMARY

EC Offset	Host Index	Register Name
330h	30h	Port 92 Enable Register

12.15.1 PORT 92 ENABLE REGISTER

Offset	30h			
Bits	Description	Type	Default	Reset Event
7:1	Reserved	RES	-	-
0	P92_EN When this bit is '1', the Port92h Register is enabled. When this bit is '0', the Port92h Register is disabled, and Host writes to address 92h are ignored.	R/W	0h	RESET_VCC

12.16 Legacy Port92/GATEA20 Runtime Registers

The registers listed in the Runtime Register Summary table are for a single instance of the Legacy Port92/GATEA20 logic. The addresses of each register listed in this table are defined as a relative offset to the host "Base Address" defined in the Runtime Register Base Address Table.

TABLE 12-14: RUNTIME REGISTER BASE ADDRESS TABLE

Block Instance	Instance Number	Host	Address Space	Base Address
Port92-Legacy	0	eSPI	I/O	0092h
		EC	32-bit address space	400F_2000h

The Base Address indicates where the first register can be accessed in a particular address space for a block instance.

TABLE 12-15: RUNTIME REGISTER SUMMARY

Offset	Register Namer
0h	Port 92 Register

MEC1725

12.16.1 PORT 92 REGISTER

Offset	0h			
Bits	Description	Type	Default	Reset Event
7:2	Reserved	RES	-	-
1	ALT_GATE_A20 This bit provides an alternate means for system control of the GATEA20 pin. ALT_A20 low drives GATEA20 low, if A20 from the keyboard controller is also low. When Port 92 is enabled, writing a 1 to this bit forces ALT_A20 high. ALT_A20 high drives GATEA20 high regardless of the state of A20 from the keyboard controller. 0=ALT_A20 is driven low 1=ALT_A20 is driven high	R/W	0h	RESET_HOST
0	ALT_CPU_RESET	R/W	0h	RESET_HOST

12.17 EC Registers

Registers for this block are shown in the following summary table. Addresses for each register are determined by adding the offset to the Base Address for each instance of the Port92-Legacy Block in the Block Overview and Base Address Table in [Section 3.0, "Device Inventory"](#).

TABLE 12-16: REGISTER SUMMARY

Offset	Register Name
100h	GATEA20 Control Register
108h	SETGA20L Register
10Ch	RSTGA20L Register

12.17.1 GATEA20 CONTROL REGISTER

Offset	100h			
Bits	Description	Type	Default	Reset Event
7:1	Reserved	RES	-	-
0	GATEA20 See Section 12.10.1, "GATE A20 Speedup" for information on this register. 0=The GATEA20 output is driven low 1=The GATEA20 output is driven high	R/W	1h	RESET_HOST

12.17.2 SETGA20L REGISTER

Offset	108h			
Bits	Description	Type	Default	Reset Event
7:0	SETGA20L See Section 12.10.1, "GATE A20 Speedup" for information on this register. A write to this register sets GATEA20 in the GATEA20 Control Register.	W	-	-

12.17.3 RSTGA20L REGISTER

Offset	10Ch			
Bits	Description	Type	Default	Reset Event
7:0	RSTGA20L See Section 12.10.1, "GATE A20 Speedup" for information on this register. A write to this register sets GATEA20 in the GATEA20 Control Register.	W	-	-

MEC1725

13.0 ACPI EMBEDDED CONTROLLER INTERFACE (ACPI-ECI)

13.1 Introduction

The [ACPI Embedded Controller Interface \(ACPI-ECI\)](#) is a Host/EC Message Interface. The ACPI specification defines the standard hardware and software communications interface between the OS and an embedded controller. This interface allows the OS to support a standard driver that can directly communicate with the embedded controller, allowing other drivers within the system to communicate with and use the EC resources; for example, Smart Battery and AML code.

The [ACPI Embedded Controller Interface \(ACPI-ECI\)](#) provides a four byte full duplex data interface which is a superset of the standard [ACPI Embedded Controller Interface \(ACPI-ECI\)](#) one byte data interface. The [ACPI Embedded Controller Interface \(ACPI-ECI\)](#) defaults to the standard one byte interface.

The MEC1725 has two instances of the ACPI Embedded Controller Interface.

1. The EC host in [Section 13.12, "Runtime Registers"](#) and [Section 13.13, "EC Registers"](#) corresponds to the EC in the ACPI specification. This interface is referred to elsewhere in this chapter as [ACPI_EC](#).
2. The eSPI host in [Section 13.12, "Runtime Registers"](#) and [Section 13.13, "EC Registers"](#) corresponds to the "System Host Interface to OS" in the ACPI specification. This interface is referred to elsewhere in this chapter as [ACPI_OS](#).

13.2 References

- Advanced Configuration and Power Interface Specification, Revision 4.0 June 16, 2009, Hewlett-Packard Corporation Intel Corporation Microsoft Corporation Phoenix Technologies Ltd. Toshiba Corporation

13.3 Terminology

TABLE 13-1: TERMINOLOGY

Term	Definition
ACPI_EC	The EC host corresponding to the ACPI specification interface to the EC.
ACPI_OS	The eSPI host corresponding to the ACPI specification interface to the "System Host Interface to OS". ACPI_OS terminology is not meant to distinguish the ACPI System Management from Operating System but merely the hardware path upstream towards the CPU.

13.4 Interface

This block is designed to be accessed internally via a register interface.

FIGURE 13-1: I/O DIAGRAM OF BLOCK

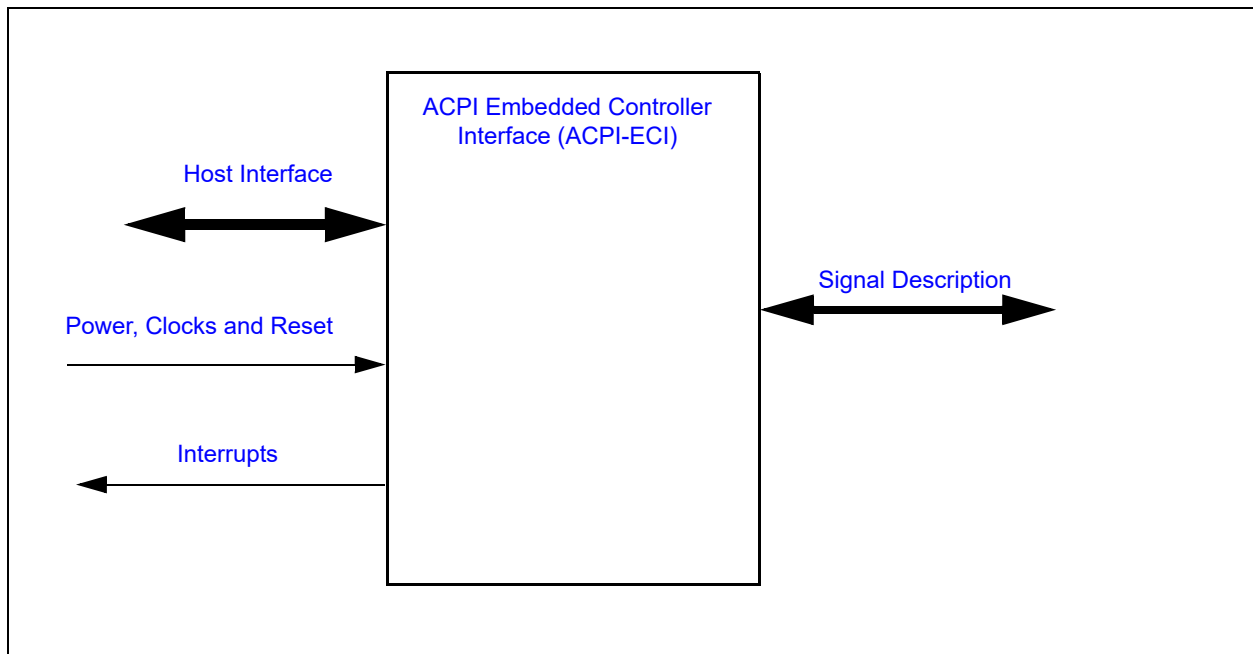

13.5 Signal Description

There are no external signals.

13.6 Host Interface

The registers defined for the [ACPI Embedded Controller Interface \(ACPI-ECI\)](#) are accessible by the various hosts as indicated in [Section 3.2, "Block Overview and Base Addresses"](#).

13.7 Power, Clocks and Reset

This section defines the Power, Clock, and Reset parameters of the block.

13.7.1 POWER DOMAINS

TABLE 13-3: POWER SOURCES

Name	Description
VTR_CORE	The logic and registers implemented in this block reside on this single power well.

13.7.2 CLOCK INPUTS

This block only requires the Host interface clocks to synchronize registers access.

MEC1725

13.7.3 RESETS

TABLE 13-4: RESET SIGNALS

Name	Description
RESET_SYS	This signal resets all the logic and registers in this interface.

13.8 Interrupts

This section defines the Interrupt Sources generated from this block.

TABLE 13-5: SYSTEM INTERRUPTS

Source	Description
EC_OBE	This host interrupt is asserted when the OBF bit in the EC STATUS Register is cleared to '0'.

TABLE 13-6: EC INTERRUPTS

Source	Description
IBF	Interrupt generated by the host writing either data or command to the data register. This interrupt is asserted when the input buffer becomes not empty (i.e., when the IBF flag goes to 1).
OBE	Interrupt generated by the host reading either data or aux data from the data register. This interrupt is asserted when the output buffer becomes empty (i.e., when the OBF flag goes to 0).
ACPIEC_INT	This is the combined OR interrupt of the above interrupts

Note: The usage model from the ACPI specification requires both SMI's and SCI's. The ACPI_OS SMI and SCI interrupts are not implemented in the ACPI Embedded Controller Interface (ACPI-ECI). The SMI_EVT and SCI_EVT bits in the OS STATUS OS Register are software flags and this block do not initiate SMI or SCI events.

13.9 Low Power Modes

The ACPI Embedded Controller Interface (ACPI-ECI) automatically enters low power mode when no transaction targets it.

13.10 Description

The [ACPI Embedded Controller Interface \(ACPI-ECI\)](#) provides an APCI-EC interface that adheres to the ACPI specification. The ACPI Embedded Controller Interface (ACPI-ECI) includes two modes of operation: [Legacy Mode](#) and [Four-byte Mode](#).

The ACPI Embedded Controller Interface (ACPI-ECI) defaults to [Legacy Mode](#) which provides single byte Full Duplex operation. [Legacy Mode](#) corresponds to the ACPI specification functionality as illustrated in [Figure 13-2, "Block Diagram corresponding to the ACPI specification"](#). The EC interrupts in [Figure 13-2](#) are implemented as OBE and IBF. See [Section 13.8, "Interrupts"](#).

In **Four-byte Mode**, the ACPI Embedded Controller Interface (ACPI-ECI) provides four byte Full Duplex operation. **Four-byte Mode** is a superset of the ACPI specification functionality as illustrated in [Figure 13-2, "Block Diagram corresponding to the ACPI specification"](#).

Both **Legacy Mode** and **Four-byte Mode** provide Full Duplex Communications which allows data/command transfers in one direction while maintaining data from the other direction; communications can flow both ways simultaneously.

In **Legacy Mode**, **ACPI Embedded Controller Interface (ACPI-ECI)** contains three registers: **ACPI OS COMMAND Register**, **OS STATUS OS Register**, and **OS2EC Data EC Byte 0 Register**. The standard **ACPI Embedded Controller Interface (ACPI-ECI)** registers occupy two addresses in the **ACPI_OS** space ([Table 13-9](#)).

The **OS2EC Data EC Byte 0 Register** and **ACPI OS COMMAND Register** registers appear as a single 8-bit data register in the **ACPI_EC**. The **CMD** bit in the **OS STATUS OS Register** is used by the **ACPI_EC** to discriminate commands from data written by the **ACPI_OS** to the **ACPI_EC**. **CMD** bit is controlled by hardware: **ACPI_OS** writes to the **OS2EC Data EC Byte 0 Register** register clear the **CMD** bit; **ACPI_OS** writes to the **ACPI OS COMMAND Register** set the **CMD** bit.

FIGURE 13-2: BLOCK DIAGRAM CORRESPONDING TO THE ACPI SPECIFICATION

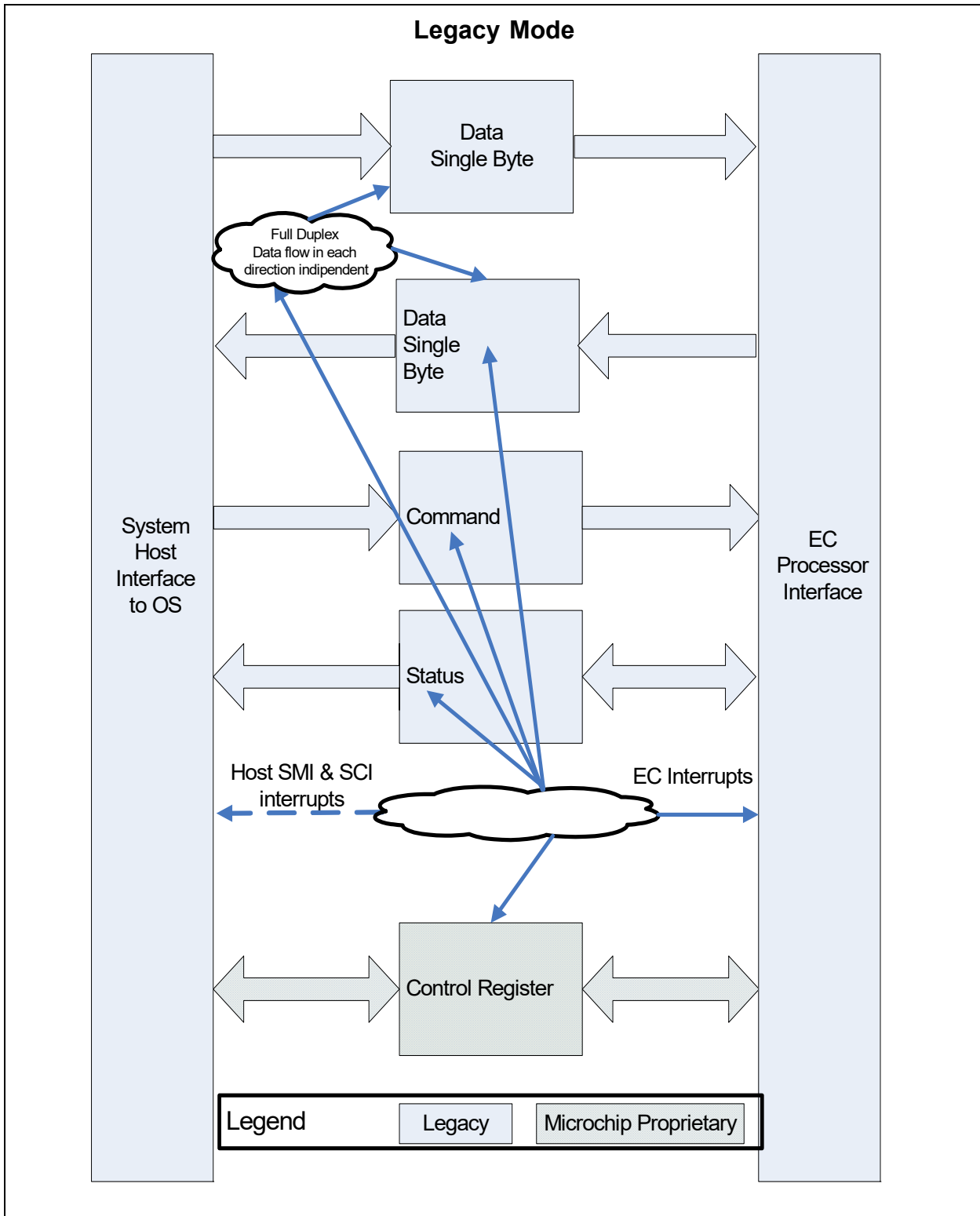
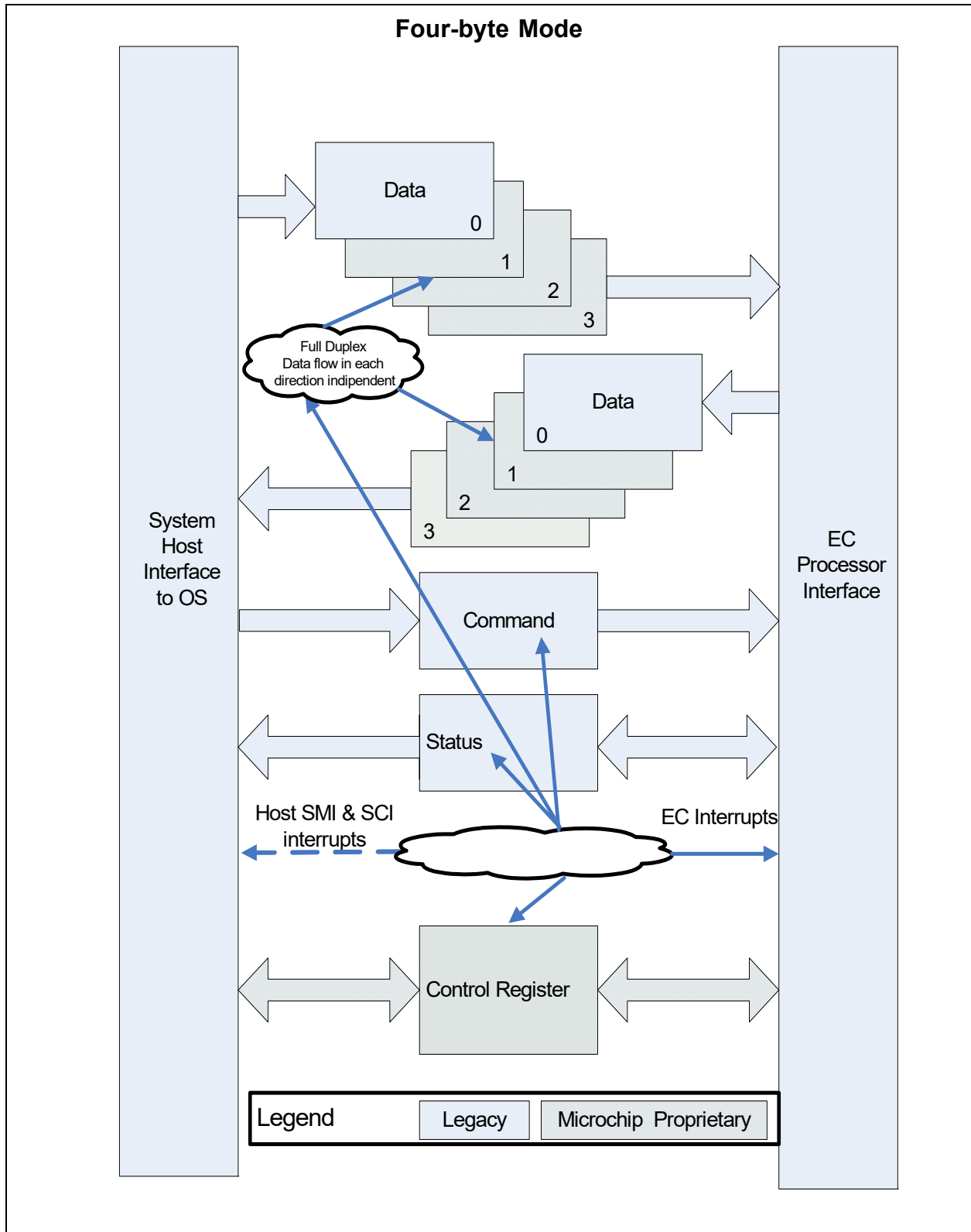

FIGURE 13-2: BLOCK DIAGRAM CORRESPONDING TO THE ACPI SPECIFICATION



MEC1725

13.11 Register Aliasing between Runtime and EC-Only Registers

Table 13-7, "Runtime Register Aliasing into EC-Only Registers" indicates the aliasing from Runtime registers to EC-Only registers. The "Host/EC Access" column distinguishes the aliasing based on access type. See individual register descriptions for more details.

TABLE 13-7: RUNTIME REGISTER ALIASING INTO EC-ONLY REGISTERS

Host Offset	Runtime Register Register Name	Host Access	EC Offset	Aliased EC-Only Register Register Name	EC Access
00h	ACPI OS Data Register Byte 0 Register	W	108h	OS2EC Data EC Byte 0 Register	R
00h	ACPI OS Data Register Byte 0 Register	R	100h	EC2OS Data EC Byte 0 Register	W
01h	ACPI OS Data Register Byte 1 Register	W	109h	OS2EC Data EC Byte 1 Register	R
01h	ACPI OS Data Register Byte 1 Register	R	101h	EC2OS Data EC Byte 1 Register	W
02h	ACPI OS Data Register Byte 2 Register	W	10Ah	OS2EC Data EC Byte 2 Register	R
02h	ACPI OS Data Register Byte 2 Register	R	102h	EC2OS Data EC Byte 2 Register	W
03h	ACPI OS Data Register Byte 3 Register	W	10Bh	OS2EC Data EC Byte 3 Register	R
03h	ACPI OS Data Register Byte 3 Register	R	103h	EC2OS Data EC Byte 3 Register	W
04h	ACPI OS COMMAND Register	W	108h	OS2EC Data EC Byte 0 Register	R
04h	OS STATUS OS Register	R	104h	EC STATUS Register	W
05h	OS Byte Control Register	R	105h	EC Byte Control Register	R/W
06h	Reserved		106h	Reserved	
07h	Reserved		107h	Reserved	

Table 13-8, "EC-Only Registers Summary" indicates the aliasing from EC-Only to Runtime registers. The "Host/EC Access" column distinguishes the aliasing based on access type. See individual register descriptions for more details.

TABLE 13-8: EC-ONLY REGISTERS SUMMARY

EC Offset	EC-Only Registers Register Name	EC Access	Host Offset	Aliased Runtime Register Register Name	Host Access
108h	OS2EC Data EC Byte 0 Register	R	00h	ACPI OS Data Register Byte 0 Register	W
108h	OS2EC Data EC Byte 0 Register	R	04h	ACPI OS COMMAND Register	W
109h	OS2EC Data EC Byte 1 Register	R	01h	ACPI OS Data Register Byte 1 Register	W
10Ah	OS2EC Data EC Byte 2 Register	R	02h	ACPI OS Data Register Byte 2 Register	W
10Bh	OS2EC Data EC Byte 3 Register	R	03h	ACPI OS Data Register Byte 3 Register	W
104h	EC STATUS Register	W	04h	OS STATUS OS Register	W
105h	EC Byte Control Register	R/W	05h	OS Byte Control Register	R
106h	Reserved	R		Reserved	R
107h	Reserved	R		Reserved	R
100h	EC2OS Data EC Byte 0 Register	W	00h	ACPI OS Data Register Byte 0 Register	R
101h	EC2OS Data EC Byte 1 Register	W	01h	ACPI OS Data Register Byte 1 Register	R
102h	EC2OS Data EC Byte 2 Register	W	02h	ACPI OS Data Register Byte 2 Register	R
103h	EC2OS Data EC Byte 3 Register	W	03h	ACPI OS Data Register Byte 3 Register	R

13.12 Runtime Registers

Note: The Runtime registers may be accessed by the EC but typically the Host will access the Runtime Registers and the EC will access just the EC-Only registers.

The registers listed in the Runtime Register Summary table are for a single instance of the [ACPI Embedded Controller Interface \(ACPI-ECI\)](#). Host access for each register listed in this table is defined as an offset in the Host address space to the Block's Base Address, as defined by the instance's Base Address Register.

The EC address for each register is formed by adding the Base Address for each instance of the [ACPI Embedded Controller Interface \(ACPI-ECI\)](#) shown in the Block Overview and Base Address Table in [Section 3.0, "Device Inventory"](#) to the offset shown in the "Offset" column.

TABLE 13-9: RUNTIME REGISTER SUMMARY

Offset	Register Name
00h	ACPI OS Data Register Byte 0 Register
01h	ACPI OS Data Register Byte 1 Register
02h	ACPI OS Data Register Byte 2 Register
03h	ACPI OS Data Register Byte 3 Register
04h	ACPI OS COMMAND Register

MEC1725

TABLE 13-9: RUNTIME REGISTER SUMMARY (CONTINUED)

Offset	Register Name
04h	OS STATUS OS Register
05h	OS Byte Control Register
06h	Reserved
07h	Reserved

13.12.1 ACPI OS DATA REGISTER BYTE 0 REGISTER

This register is aliased; see [Section 13.12.1.1, "ACPI-OS DATA BYTES\[3:0\]"](#), [Section 13.13.1.1, "OS2EC DATA BYTES\[3:0\]"](#), and [Section 13.13.5.1, "EC2OS DATA BYTES\[3:0\]"](#) for detailed descriptions of access rules.

Offset	00h			
Bits	Description	Type	Default	Reset Event
7:0	ACPI_OS_DATA_BYTE_0 This is byte 0 of the 32-bit ACPI-OS DATA BYTES[3:0] .	R/W	0h	RESET_SYS

13.12.1.1 ACPI-OS DATA BYTES[3:0]

Writes by the [ACPI_OS](#) to the [ACPI-OS DATA BYTES\[3:0\]](#) are aliased to the [OS2EC DATA BYTES\[3:0\]](#). Reads by the [ACPI_OS](#) from the [ACPI-OS DATA BYTES\[3:0\]](#) are aliased to the [EC2OS DATA BYTES\[3:0\]](#).

All access to the [ACPI-OS DATA BYTES\[3:0\]](#) registers should be orderly: Least Significant Byte to Most Significant Byte when byte access is used.

Writes to any of the four [ACPI-OS DATA BYTES\[3:0\]](#) registers clears the [CMD](#) bit in the [OS STATUS OS Register](#) (the state of the [FOUR_BYTE_ACCESS](#) bit in the [OS Byte Control Register](#) has no impact.)

When the [FOUR_BYTE_ACCESS](#) bit in the [OS Byte Control Register](#) is cleared to '0', the following access rules apply:

- Writes to the [ACPI OS Data Register Byte 0 Register](#) sets the [IBF](#) bit in the [OS STATUS OS Register](#).
- Reads from the [ACPI OS Data Register Byte 0 Register](#) clears the [OBF](#) bit in the [OS STATUS OS Register](#).
- All writes to [ACPI-OS DATA BYTES\[3:1\]](#) complete without error but the data are not registered.
- All reads from [ACPI-OS DATA BYTES\[3:1\]](#) return 00h without error.
- Access to [ACPI-OS DATA BYTES\[3:1\]](#) has no effect on the [IBF](#) and [OBF](#) bits in the [OS STATUS OS Register](#).

When the [Four Byte Access](#) bit in the [OS Byte Control Register](#) is set to '1', the following access rules apply:

- Writes to the [ACPI OS Data Register Byte 3 Register](#) sets the [IBF](#) bit in the [OS STATUS OS Register](#).
- Reads from the [ACPI OS Data Register Byte 3 Register](#) clears the [OBF](#) bit in the [OS STATUS OS Register](#).

13.12.2 ACPI OS DATA REGISTER BYTE 1 REGISTER

This register is aliased; see [Section 13.12.1.1, "ACPI-OS DATA BYTES\[3:0\]"](#), [Section 13.13.1.1, "OS2EC DATA BYTES\[3:0\]"](#), and [Section 13.13.5.1, "EC2OS DATA BYTES\[3:0\]"](#) for detailed descriptions of access rules.

Offset	01h			
Bits	Description	Type	Default	Reset Event
7:0	ACPI_OS_DATA_BYTE_1 This is byte 1 of the 32-bit ACPI-OS DATA BYTES[3:0] .	R/W	0h	RESET_SYS

13.12.3 ACPI OS DATA REGISTER BYTE 2 REGISTER

This register is aliased; see [Section 13.12.1.1, "ACPI-OS DATA BYTES\[3:0\]"](#), [Section 13.13.1.1, "OS2EC DATA BYTES\[3:0\]"](#), and [Section 13.13.5.1, "EC2OS DATA BYTES\[3:0\]"](#) for detailed descriptions of access rules.

Offset	02h			
Bits	Description	Type	Default	Reset Event
7:0	ACPI_OS_DATA_BYTE_2 This is byte 2 of the 32-bit ACPI-OS DATA BYTES[3:0] .	R/W	0h	RESET_SYS

13.12.4 ACPI OS DATA REGISTER BYTE 3 REGISTER

This register is aliased; see [Section 13.12.1.1, "ACPI-OS DATA BYTES\[3:0\]"](#), [Section 13.13.1.1, "OS2EC DATA BYTES\[3:0\]"](#), and [Section 13.13.5.1, "EC2OS DATA BYTES\[3:0\]"](#) for detailed descriptions of access rules.

Offset	03h			
Bits	Description	Type	Default	Reset Event
7:0	ACPI_OS_DATA_BYTE_3 This is byte 3 of the 32-bit ACPI-OS DATA BYTES[3:0] .	R/W	0h	RESET_SYS

13.12.5 ACPI OS COMMAND REGISTER

Offset	04h			
Bits	Description	Type	Default	Reset Event
7:0	ACPI_OSS_COMMAND Writes to the this register are aliased in the OS2EC Data EC Byte 0 Register . Writes to the this register also set the CMD and IBF bits in the OS STATUS OS Register	W	0h	RESET_SYS

13.12.6 OS STATUS OS REGISTER

This read-only register is aliased to the [EC STATUS Register](#). The [EC STATUS Register](#) has read write access.

Offset	04h			
Bits	Description	Type	Default	Reset Event
7	UD0B User Defined	R	0b	RESET_SYS

MEC1725

Offset	04h			
Bits	Description	Type	Default	Reset Event
6	<p>SMI_EVT</p> <p>This bit is set when an SMI event is pending; i.e., the ACPI_EC is requesting an SMI query; This bit is cleared when no SMI events are pending.</p> <p>This bit is an ACPI_EC-maintained software flag that is set when the ACPI_EC has detected an internal event that requires system management interrupt handler attention. The ACPI_EC sets this bit before generating an SMI.</p> <p>Note: The usage model from the ACPI specification requires both SMI's and SCI's. The ACPI_OS SMI and SCI interrupts are not implemented in the ACPI Embedded Controller Interface (ACPI-ECI). The SMI_EVT and SCI_EVT bits in the OS STATUS OS Register are software flags and this block do not initiate SMI or SCI events.</p>	R	0b	RESET_SYS
5	<p>SCI_EVT</p> <p>This bit is set by software when an SCI event is pending; i.e., the ACPI_EC is requesting an SCI query; SCI Event flag is clear when no SCI events are pending.</p> <p>This bit is an ACPI_EC-maintained software flag that is set when the embedded controller has detected an internal event that requires operating system attention. The ACPI_EC sets this bit before generating an SCI to the OS.</p> <p>Note: The usage model from the ACPI specification requires both SMI's and SCI's. The ACPI_OS SMI and SCI interrupts are not implemented in the ACPI Embedded Controller Interface (ACPI-ECI). The SMI_EVT and SCI_EVT bits in the OS STATUS OS Register are software flags and this block do not initiate SMI or SCI events.</p>	R	0b	RESET_SYS
4	<p>BURST</p> <p>The BURST bit is set when the ACPI_EC is in Burst Mode for polled command processing; the BURST bit is cleared when the ACPI_EC is in Normal mode for interrupt-driven command processing.</p> <p>The BURST bit is an ACPI_EC-maintained software flag that indicates the embedded controller has received the Burst Enable command from the host, has halted normal processing, and is waiting for a series of commands to be sent from the host. Burst Mode allows the OS or system management handler to quickly read and write several bytes of data at a time without the overhead of SCIs between commands.</p> <p>The BURST bit is maintained by ACPI_EC software, only.</p>	R	0b	RESET_SYS

Offset	04h			
Bits	Description	Type	Default	Reset Event
3	<p>CMD</p> <p>This bit is set when the OS2EC Data EC Byte 0 Register contains a command byte written into ACPI OS COMMAND Register; this bit is cleared when the OS2EC DATA BYTES[3:0] contains a data byte written into the ACPI-OS DATA BYTES[3:0].</p> <p>This bit is hardware controlled:</p> <ul style="list-style-type: none"> • ACPI_OS writes to any of the four ACPI-OS DATA BYTES[3:0] bytes clears this bit • ACPI_OS writes to the ACPI OS COMMAND Register sets this bit. <p>Note: This bit allows the embedded controller to differentiate the start of a command sequence from a data byte write operation.</p>	R	0b	RESET_SYS
2	<p>UD1B</p> <p>User Defined</p>	R	0b	RESET_SYS

MEC1725

Offset	04h			
Bits	Description	Type	Default	Reset Event
1	<p>IBF</p> <p>The Input Buffer Full bit is set to indicate that a the ACPI_OS has written a command or data to the ACPI_EC and that data is ready. This bit is automatically cleared when data has been read by the ACPI_EC.</p> <p>Note: The setting and clearing of this IBF varies depending on the setting of the following bits: CMD bit in this register and FOUR_BYTE_ACCESS bit in the OS Byte Control Register. Three scenarios follow:</p> <ol style="list-style-type: none"> 1. The IBF is set when the ACPI_OS writes to the ACPI OS COMMAND Register. This same write autonomously sets the CMD bit in this register. <p>The IBF is cleared if the CMD bit in this register is set and the ACPI_EC reads from the OS2EC Data EC Byte 0 Register.</p> <p>Note: When CMD bit in this register is set the FOUR_BYTE_ACCESS bit in the OS Byte Control Register has no impact on the IBF bit behavior.</p> <ol style="list-style-type: none"> 2. A write by the to the ACPI_OS to the ACPI OS Data Register Byte 0 Register sets the IBF bit if the FOUR_BYTE_ACCESS bit in the OS Byte Control Register is in the cleared to '0' state prior to this write. This same write autonomously clears the CMD bit in this register. <p>A read of the OS2EC Data EC Byte 0 Register clears the IBF bit if the FOUR_BYTE_ACCESS bit in the OS Byte Control Register is in the cleared to '0' state prior to this read.</p> <ol style="list-style-type: none"> 3. A write by the to the ACPI_OS to the ACPI OS Data Register Byte 3 Register sets the IBF bit if the FOUR_BYTE_ACCESS bit in the OS Byte Control Register is in the set to '1' state prior to this write. This same write autonomously clears the CMD bit in this register. <p>A read of the OS2EC Data EC Byte 3 Register clears the IBF bit if the FOUR_BYTE_ACCESS bit in the OS Byte Control Register is in the set to '1' state prior to this read.</p> <p>An IBF interrupt signals the ACPI_EC that there is data available. The ACPI Specification usage model is as follows:</p> <ol style="list-style-type: none"> 1. The ACPI_EC reads the EC STATUS Register and sees the IBF flag set, 2. The ACPI_EC reads all the data available in the OS2EC DATA BYTES[3:0]. This causes the IBF bit to be automatically cleared by hardware. 3. The ACPI_EC must then generate a software interrupt to alert the ACPI_OS that the data has been read and that the host is free to write more data to the ACPI_EC as needed. 	R	0h	RESET_SYS

Offset	04h			
Bits	Description	Type	Default	Reset Event
0	<p>OBF</p> <p>The Output Buffer Full bit is set to indicate that a the ACPI_EC has written a data to the ACPI_OS and that data is ready. This bit is automatically cleared when all the data has been read by the ACPI_OS.</p> <p>Note: The setting and clearing of this OBF varies depending on the setting FOUR_BYTE_ACCESS bit in the OS Byte Control Register. Two scenarios follow:</p> <ol style="list-style-type: none"> 1. The OBF bit is set if the Four Byte Access bit in the OS Byte Control Register is '0' when the ACPI_EC writes to the EC2OS Data EC Byte 0 Register. <p>The OBF is cleared if the Four Byte Access bit in the OS Byte Control Register is cleared to '0' when the ACPI_OS reads from the ACPI OS Data Register Byte 0 Register.</p> <ol style="list-style-type: none"> 2. The OBF is set if the Four Byte Access bit in the OS Byte Control Register is set to '1' when the ACPI_EC writes to the EC2OS Data EC Byte 3 Register. <p>The OBF is cleared if the Four Byte Access bit in the OS Byte Control Register is set to '1' when the ACPI_OS reads from the ACPI OS Data Register Byte 3 Register.</p> <p>The ACPI Specification usage model is as follows:</p> <ol style="list-style-type: none"> 1. The ACPI_EC must generate a software interrupt (See the note in Section 13.8, "Interrupts") to alert the ACPI_OS that the data is available. 2. The ACPI_OS reads the OS STATUS OS Register and sees the OBF flag set, the ACPI_OS reads all the data available in the ACPI-OS DATA BYTES[3:0]. 3. The ACPI_OS reads all the data available in the ACPI-OS DATA BYTES[3:0]. This causes the OBF bit to be automatically cleared by hardware and the associated OBE interrupt to be asserted. 	R	0h	RESET_SYS

MEC1725

13.12.7 OS BYTE CONTROL REGISTER

This register is aliased to the [EC Byte Control Register](#). No behavioral differences occur due to address aliasing.

Offset	05			
Bits	Description	Type	Default	Reset Event
7:1	Reserved	RES	-	-
0	FOUR_BYTE_ACCESS When this bit is set to '1', the ACPI Embedded Controller Interface (ACPI-ECI) accesses four bytes through the ACPI-OS DATA BYTES[3:0] . When this bit is cleared to '0', the ACPI Embedded Controller Interface (ACPI-ECI) accesses one byte through the ACPI OS Data Register Byte 0 Register . The corresponds to Legacy Mode described in Section 13.10, "Description" . This bit effects the behavior of the IBF and OBF bits in the OS STATUS OS Register . See also Section 13.12.1.1, "ACPI-OS DATA BYTES[3:0]" , Section 13.13.1.1, "OS2EC DATA BYTES[3:0]" , and Section 13.13.5.1, "EC2OS DATA BYTES[3:0]" for detailed description of access rules.	R	0b	RESET_SYS

Note: The ACPI_OS access Base Address Register (BAR) should be configured to match the access width selected by the Four Byte Access bit in the OS Byte Control Register. This BAR is not described in this chapter.

13.13 EC Registers

Registers for this block are shown in the following summary table. Addresses for each register are determined by adding the offset to the Base Address for each instance of the [ACPI Embedded Controller Interface \(ACPI-ECI\)](#) Block in the Block Overview and Base Address Table in [Section 3.0, "Device Inventory"](#).

TABLE 13-10: REGISTER SUMMARY

Offset	Register Name
100h	EC2OS Data EC Byte 0 Register
101h	EC2OS Data EC Byte 1 Register
102h	EC2OS Data EC Byte 2 Register
103h	EC2OS Data EC Byte 3 Register
104h	EC STATUS Register
105h	EC Byte Control Register
106h	Reserved
107h	Reserved
108h	OS2EC Data EC Byte 0 Register
109h	OS2EC Data EC Byte 1 Register
10Ah	OS2EC Data EC Byte 2 Register
10Bh	OS2EC Data EC Byte 3 Register

13.13.1 OS2EC DATA EC BYTE 0 REGISTER

This register is aliased; see [Section 13.12.1.1, "ACPI-OS DATA BYTES\[3:0\]"](#), [Section 13.13.1.1, "OS2EC DATA BYTES\[3:0\]"](#), and [Section 13.13.5.1, "EC2OS DATA BYTES\[3:0\]"](#) for detailed descriptions of access rules.

Offset	108h			
Bits	Description	Type	Default	Reset Event
7:0	OS_TO_EC_DATA_BYTE_0 This is byte 0 of the 32-bit OS2EC DATA BYTES[3:0] .	R/W	0h	RESET_SYS

13.13.1.1 OS2EC DATA BYTES[3:0]

When the [CMD](#) bit in the [OS STATUS OS Register](#) is cleared to '0', reads by the [ACPI_EC](#) from the [OS2EC DATA BYTES\[3:0\]](#) are aliased to the [ACPI-OS DATA BYTES\[3:0\]](#).

All access to the [OS2EC DATA BYTES\[3:0\]](#) registers should be orderly: Least Significant Byte to Most Significant Byte when byte access is used.

When the [FOUR_BYTE_ACCESS](#) bit in the [OS Byte Control Register](#) is cleared to '0', the following access rules apply:

- Writes to the [OS2EC DATA BYTES\[3:0\]](#) have no effect on the [OBF](#) bit in the [OS STATUS OS Register](#).
- Reads from the [OS2EC Data EC Byte 0 Register](#) clears the [IBF](#) bit in the [OS STATUS OS Register](#).
- All reads from [OS2EC DATA BYTES\[3:1\]](#) return 00h without error.
- Access to [OS2EC DATA BYTES\[3:1\]](#) has no effect on the [IBF](#) and [OBF](#) bits in the [OS STATUS OS Register](#).

When the [FOUR_BYTE_ACCESS](#) bit in the [OS Byte Control Register](#) is set to '1', the following access rules apply:

- Writes to the [OS2EC DATA BYTES\[3:0\]](#) have no effect on the [OBF](#) bit in the [OS STATUS OS Register](#).
- Reads from the [OS2EC Data EC Byte 3 Register](#) clears the [IBF](#) bit in the [OS STATUS OS Register](#).

13.13.2 OS2EC DATA EC BYTE 1 REGISTER

This register is aliased; see [Section 13.12.1.1, "ACPI-OS DATA BYTES\[3:0\]"](#), [Section 13.13.1.1, "OS2EC DATA BYTES\[3:0\]"](#), and [Section 13.13.5.1, "EC2OS DATA BYTES\[3:0\]"](#) for detailed descriptions of access rules.

Offset	109h			
Bits	Description	Type	Default	Reset Event
7:0	OS2EC_DATA_BYTE_1 This is byte 1 of the 32-bit OS2EC DATA BYTES[3:0] .	R/W	0h	RESET_SYS

13.13.3 OS2EC DATA EC BYTE 2 REGISTER

This register is aliased; see [Section 13.12.1.1, "ACPI-OS DATA BYTES\[3:0\]"](#), [Section 13.13.1.1, "OS2EC DATA BYTES\[3:0\]"](#), and [Section 13.13.5.1, "EC2OS DATA BYTES\[3:0\]"](#) for detailed descriptions of access rules.

MEC1725

Offset	10Ah			
Bits	Description	Type	Default	Reset Event
7:0	OS2EC_DATA_BYTE_2 This is byte 2 of the 32-bit OS2EC DATA BYTES[3:0] .	R/W	0h	RESET_SYS

13.13.4 OS2EC DATA EC BYTE 3 REGISTER

This register is aliased; see [Section 13.12.1.1, "ACPI-OS DATA BYTES\[3:0\]"](#), [Section 13.13.1.1, "OS2EC DATA BYTES\[3:0\]"](#), and [Section 13.13.5.1, "EC2OS DATA BYTES\[3:0\]"](#) for detailed descriptions of access rules.

Offset	10Bh			
Bits	Description	Type	Default	Reset Event
7:0	OS2EC_DATA_BYTE_3 This is byte 3 of the 32-bit OS2EC DATA BYTES[3:0] .	R/W	0h	RESET_SYS

13.13.5 EC2OS DATA EC BYTE 0 REGISTER

This register is aliased; see [Section 13.12.1.1, "ACPI-OS DATA BYTES\[3:0\]"](#), [Section 13.13.1.1, "OS2EC DATA BYTES\[3:0\]"](#), and [Section 13.13.5.1, "EC2OS DATA BYTES\[3:0\]"](#) for detailed descriptions of access rules.

Offset	100h			
Bits	Description	Type	Default	Reset Event
7:0	EC2OS_DATA_BYTE_0 This is byte 0 of the 32-bit EC2OS DATA BYTES[3:0] .	R/W	0h	RESET_SYS

13.13.5.1 EC2OS DATA BYTES[3:0]

Writes by the [ACPI_EC](#) to the [EC2OS DATA BYTES\[3:0\]](#) are aliased to the [ACPI-OS DATA BYTES\[3:0\]](#)

All access to the [EC2OS DATA BYTES\[3:0\]](#) registers should be orderly: Least Significant Byte to Most Significant Byte when byte access is used.

When the [FOUR_BYTE_ACCESS](#) bit in the [OS Byte Control Register](#) is cleared to '0', the following access rules apply:

1. Writes to the [EC2OS Data EC Byte 0 Register](#) set the [OBF](#) bit in the [OS STATUS OS Register](#).
2. Reads from the [EC2OS DATA BYTES\[3:0\]](#) have no effect on the [IBF](#) bit in the [OS STATUS OS Register](#).
3. All reads from [EC2OS DATA BYTES\[3:1\]](#) return 00h without error.
4. All writes to [EC2OS DATA BYTES\[3:1\]](#) complete without error but the data are not registered.
5. Access to [EC2OS DATA BYTES\[3:1\]](#) have no effect on the [IBF](#) and [OBF](#) bits in the [OS STATUS OS Register](#).

When the [FOUR_BYTE_ACCESS](#) bit in the [OS Byte Control Register](#) is set to '1', the following access rules apply:

1. Writes to the [EC2OS Data EC Byte 3 Register](#) set the [OBF](#) bit in the [OS STATUS OS Register](#).
2. Reads from the [EC2OS DATA BYTES\[3:0\]](#) have no effect on the [IBF](#) bit in the [OS STATUS OS Register](#).

13.13.6 EC2OS DATA EC BYTE 1 REGISTER

This register is aliased; see [Section 13.12.1.1, "ACPI-OS DATA BYTES\[3:0\]"](#), [Section 13.13.1.1, "OS2EC DATA BYTES\[3:0\]"](#), and [Section 13.13.5.1, "EC2OS DATA BYTES\[3:0\]"](#) for detailed descriptions of access rules.

Offset	101h			
Bits	Description	Type	Default	Reset Event
7:0	EC2OS_DATA_BYTE_1 This is byte 1 of the 32-bit EC2OS DATA BYTES[3:0] .	R/W	0h	RESET_SYS

13.13.7 EC2OS DATA EC BYTE 2 REGISTER

This register is aliased; see [Section 13.12.1.1, "ACPI-OS DATA BYTES\[3:0\]"](#), [Section 13.13.1.1, "OS2EC DATA BYTES\[3:0\]"](#), and [Section 13.13.5.1, "EC2OS DATA BYTES\[3:0\]"](#) for detailed descriptions of access rules.

Offset	102h			
Bits	Description	Type	Default	Reset Event
7:0	EC2OS_DATA_BYTE_2 This is byte 2 of the 32-bit EC2OS DATA BYTES[3:0] .	R/W	0h	RESET_SYS

13.13.8 EC2OS DATA EC BYTE 3 REGISTER

This register is aliased; see [Section 13.12.1.1, "ACPI-OS DATA BYTES\[3:0\]"](#), [Section 13.13.1.1, "OS2EC DATA BYTES\[3:0\]"](#), and [Section 13.13.5.1, "EC2OS DATA BYTES\[3:0\]"](#) for detailed descriptions of access rules.

Offset	103h			
Bits	Description	Type	Default	Reset Event
7:0	EC2OS_DATA_BYTE_3 This is byte 3 of the 32-bit EC2OS DATA BYTES[3:0] .	R/W	0h	RESET_SYS

MEC1725

13.13.9 EC STATUS REGISTER

This register is aliased to the [OS STATUS OS Register](#). The [OS STATUS OS Register](#) is a read only version of this register.

Offset	104h			
Bits	Description	Type	Default	Reset Event
7	UD0A User Defined	R/W	0b	RESET _SYS
6	SMI_EVT See the SMI_EVT bit in the OS STATUS OS Register for the bit description.	R/W	0b	RESET _SYS
5	SCI_EVT See the SMI_EVT bit in the OS STATUS OS Register for the bit description.	R/W	0b	RESET _SYS
4	BURST See the BURST bit in the OS STATUS OS Register for the bit description.	R/W	0b	RESET _SYS
3	CMD See the CMD bit in the OS STATUS OS Register for the bit description.	R	0b	RESET _SYS
2	UD1A User Defined	R/W	0b	RESET _SYS
1	IBF See the IBF bit in the OS STATUS OS Register for the bit description.	R	0h	RESET _SYS
0	OBF See the OBF bit in the OS STATUS OS Register for the bit description.	R	0h	RESET _SYS

Note: The [IBF](#) and [OBF](#) bits are not de-asserted by hardware when the host is powered off, or the eSPI interface powers down; for example, following system state changes S3->S0, S5->S0, G3-> S0. For further information on how these bits are cleared, refer to [IBF](#) and [OBF](#) bit descriptions in the STATUS OS-Register definition.

13.13.10 EC BYTE CONTROL REGISTER

This register is aliased to the [OS Byte Control Register](#). The [OS Byte Control Register](#) is a read only version of this register.

Offset	105h			
Bits	Description	Type	Default	Reset Event
7:1	Reserved	RES	-	-
0	FOUR_BYTE_ACCESS See the FOUR_BYTE_ACCESS bit in the OS Byte Control Register for the bit description.	R/W	0b	RESET_SYS

MEC1725

14.0 ACPI PM1 BLOCK

14.1 Introduction

The MEC1725 supports ACPI as described in this section. These features comply with the ACPI Specification through a combination of hardware and EC software.

14.2 References

ACPI Specification, Revision 1.0

14.3 Terminology

None

14.4 Interface

This block is an IP block designed to be incorporated into a chip. It is designed to be accessed externally via the pin interface and internally via a registered host interface. The following diagram illustrates the various interfaces to the block.

FIGURE 14-1: I/O DIAGRAM OF BLOCK

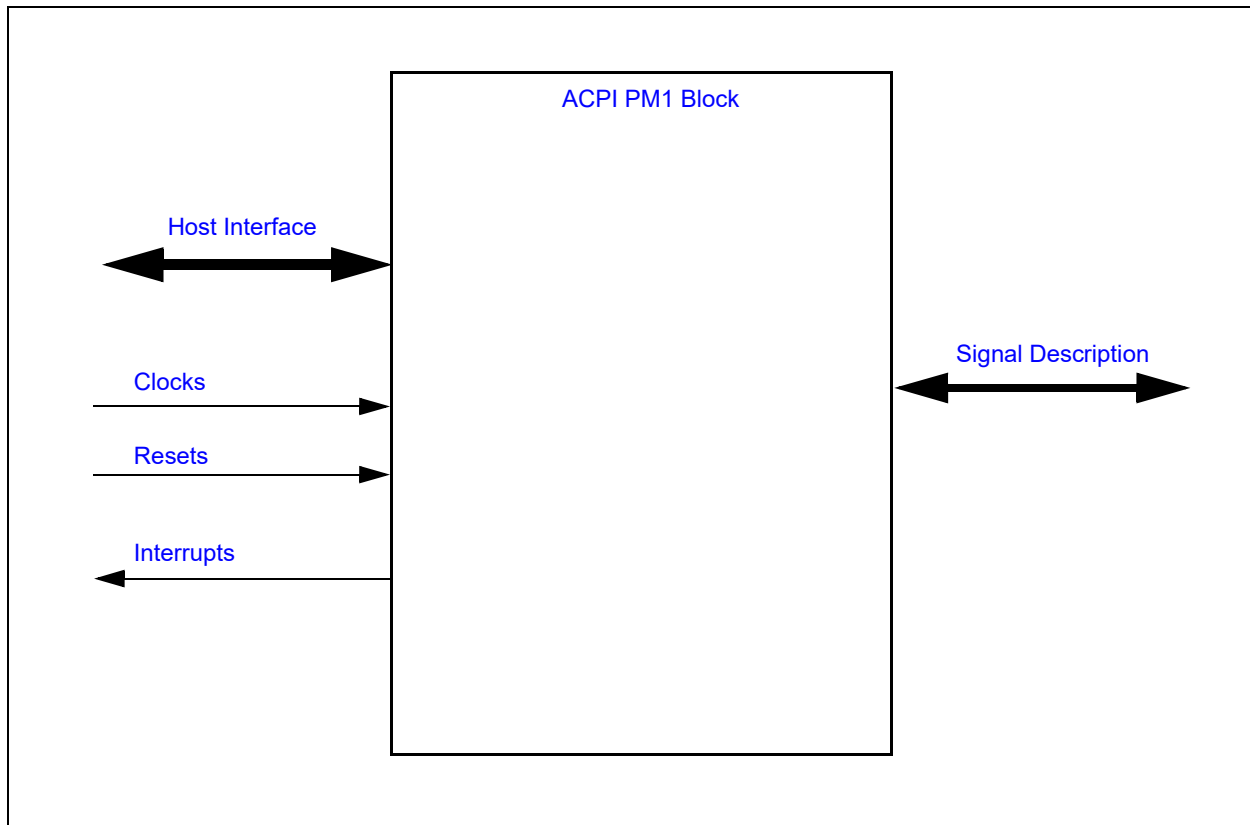

14.5 Signal Description

Table 14-1, "ACPI PM1 Signal Description Table" lists the signals that are typically routed to the pin interface.

TABLE 14-1: ACPI PM1 SIGNAL DESCRIPTION TABLE

Name	Direction	Description
nEC_SCI	Output	Any or all of the PWRBTN_STS , SLPBTN_STS , and RTC_STS bits in the Power Management 1 Status 2 Register can assert the nEC_SCI pin if enabled by the associated bits in the Power Management 1 Enable 2 Register register. The EC_SCI_STS bit in the EC_PM_STS Register register can also be used to generate an SCI on the nEC_SCI pin.

14.6 Host Interface

The registers defined for the [ACPI PM1 Block](#) are accessible by the various hosts as indicated in [Section 3.2, "Block Overview and Base Addresses"](#).

14.7 Power, Clocks and Resets

This section defines the Power, Clock, and Reset parameters of the block.

14.7.1 POWER DOMAINS

TABLE 14-2: POWER SOURCES

Name	Description
VTR_CORE	This power well sources the registers and logic in this block.

14.7.2 CLOCKS

This section describes all the clocks in the block, including those that are derived from the I/O Interface as well as the ones that are derived or generated internally.

TABLE 14-3: CLOCKS

Name	Description
48MHz	This clock signal drives selected logic (e.g., counters).

14.7.3 RESETS

TABLE 14-4: RESET SIGNALS

Name	Description
RESET_SYS	This reset signal resets all of the registers and logic in this block.

14.8 Interrupts

This section defines the Interrupt Sources generated from this block.

TABLE 14-5: EC INTERRUPTS

Source	Description
PM1_CTL	This Interrupt is generated to the EC by the Host writing to the Power Management 1 Control 2 Register register
PM1_EN	This Interrupt is generated to the EC by the Host writing to the Power Management 1 Enable 2 Register register
PM1_STS	This Interrupt is generated to the EC by the Host writing to the Power Management 1 Status 2 Register register

MEC1725

14.9 Low Power Modes

The [ACPI PM1 Block](#) may be put into a low power state by the chip's Power, Clocks, and Reset (PCR) circuitry.

14.10 Description

This section describes the functions of the [ACPI PM1 Block](#) in more detail.

The MEC1725 implements the ACPI fixed registers but includes only those bits that apply to the power button sleep button and RTC alarm events. The ACPI [WAK_STS](#), [SLP_TYP](#), and [SLP_EN](#) bits are also supported.

The MEC1725 can generate SCI Interrupts to the Host. The functions described in the following sub-sections can generate a SCI event on the [nEC_SCI](#) pin. In the MEC1725, an SCI event is considered the same as an ACPI wakeup or runtime event.

14.10.1 SCI EVENT-GENERATING FUNCTIONS

Event	Event Bit	Definition
Power Button with Override	PWRBTN_STS	<p>The power button has a status and an enable bit in the PM1_BLK of registers to provide an SCI upon the button press. The status bit is software Read/Writable by the EC; the enable bit is Read-only by the EC. It also has a status and enable bit in the PM1_BLK of registers to indicate and control the power button override (fail-safe) event. These bits are not required by ACPI.</p> <p>The PWRBTN_STS bit is set by the Host to enable the generation of an SCI due to the power button event. The status bit is set by the EC when it generates a power button event and is cleared by the Host writing a '1' to this bit (writing a '0' has no effect); it can also be cleared by the EC. If the enable bit is set, the EC generates an SCI power management event.</p>
	PWRBTNOR_STS	<p>The power button has a status and an enable bit in the PM1_BLK of registers to provide an SCI upon the power button override. The power button override event status bit is software Read/Writable by the EC; the enable bit is software read-only by the EC. The enable bit for the override event is located at bit 1 in the Power Management 1 Control Register 2 (PM1_CNTRL 2). The power button bit has a status and enable bit in the Runtime Registers to provide an SCI power management event on a button press</p> <p>The PWRBTNOR_STS bit is set by the Host to enable the generation of an SCI due to the power button override event. The status bit is set by the EC when it generates a power button event and is cleared by the Host writing a '1' to this bit (writing a '0' has no effect); it can also be cleared by the EC. If the enable bit is set, the EC generates an SCI power management event.</p>
Sleep Button	SLPBTN_STS	<p>The sleep button that has a status and an enable bit in the Runtime Registers to provide an SCI power management event on a button press. The status bit is software Read/Writable by the EC; the enable bit is Read-only by the EC.</p> <p>The SLPBTN_STS bit is set by the Host to enable the generation of an SCI due to the sleep button event. The status bit is set by the EC when it generates a sleep button event and is cleared by the Host writing a '1' to this bit (writing a '0' has no effect); it can also be cleared by the EC. If the enable bit is set, the EC will generate an SCI power management event.</p>

Event	Event Bit	Definition
RTC Alarm	RTC_STS	<p>The ACPI specification requires that the RTC alarm generate a hardware wake-up event from the sleeping state. The RTC alarm can be enabled as an SCI event and its status can be determined through bits in the Runtime Registers. The status bit is software Read/Writable by the EC; the enable bit is Read-only by the EC.</p> <p>The RTC_STS bit is set by the Host to enable the generation of an SCI due to the RTC alarm event. The status bit is set by the EC when the RTC generates an alarm event and is cleared by the Host writing a '1' to this bit (writing a '0' has no effect); it can also be cleared by the EC. If the enable bit is set, the EC will generate an SCI power management event.</p>

Figure 14-2 describes the relationship of PM1 Status and Enable bits to the [nEC_SCI](#) pin.

FIGURE 14-2: EC_SCI# INTERFACE

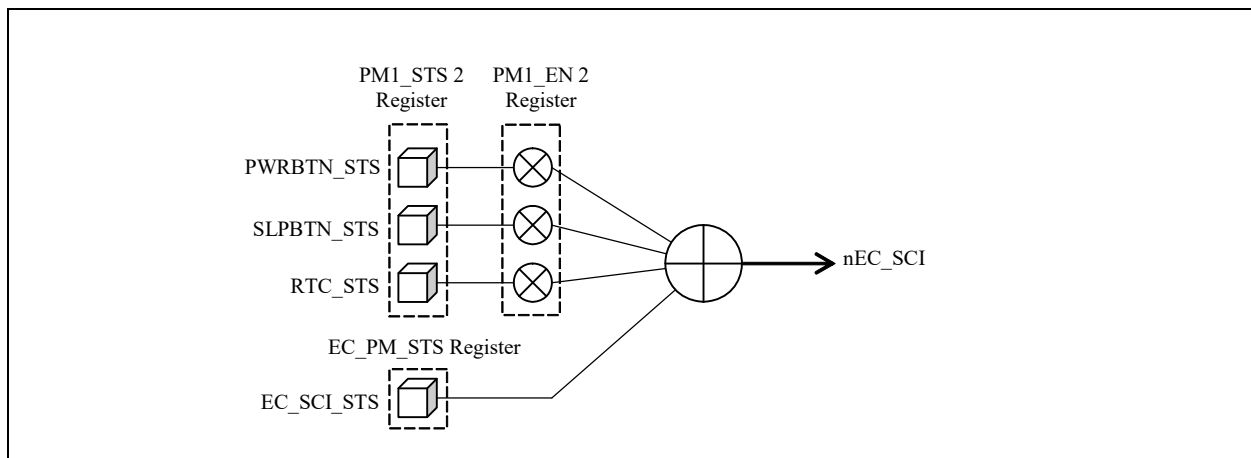

14.11 Runtime Registers

The registers listed in the Runtime Register Summary table are for a single instance of the [ACPI PM1 Block](#). Host access for each register listed in this table is defined as an offset in the Host address space to the Block's Base Address, as defined by the instance's Base Address Register.

The EC address for each register is formed by adding the Base Address for the [ACPI PM1 Block](#) shown in the Block Overview and Base Address Table in [Section 3.0, "Device Inventory"](#) to the offset shown in the "Offset" column.

TABLE 14-6: RUNTIME REGISTER SUMMARY

Offset	Register Name
00h	Power Management 1 Status 1 Register
01h	Power Management 1 Status 2 Register
02h	Power Management 1 Enable 1 Register
03h	Power Management 1 Enable 2 Register
04h	Power Management 1 Control 1 Register
05h	Power Management 1 Control 2 Register
06h	Power Management 2 Control 1 Register
07h	Power Management 2 Control 2 Register

MEC1725

14.11.1 POWER MANAGEMENT 1 STATUS 1 REGISTER

Offset	00h	Bits	Description	Type	Default	Reset Event
7:0	Reserved			RES	-	-

14.11.2 POWER MANAGEMENT 1 STATUS 2 REGISTER

Offset	01h	Bits	Description	Type	Default	Reset Event
7	WAK_STS This bit can be set or cleared by the EC. The Host writing a one to this bit can also clear this bit.	R/WC (Note 1)	00h	RESET_SYS		
6:4	Reserved	RES	-	-		
3	PWRBTNOR_STS This bit can be set or cleared by the EC to simulate a Power button override event status if the power is controlled by the EC. The Host writing a one to this bit can also clear this bit. The EC must generate the associated hardware event under software control.	R/WC (Note 1)	00h	RESET_SYS		
2	RTC_STS This bit can be set or cleared by the EC to simulate a RTC status. The Host writing a one to this bit can also clear this bit. The EC must generate the associated SCI interrupt under software control.	R/WC (Note 1)	00h	RESET_SYS		
1	SLPBTN_STS This bit can be set or cleared by the EC to simulate a Sleep button status if the sleep state is controlled by the EC. The Host writing a one to this bit can also clear this bit. The EC must generate the associated SCI interrupt under software control.	R/WC (Note 1)	00h	RESET_SYS		
0	PWRBTN_STS This bit can be set or cleared by the EC to simulate a Power button status if the power is controlled by the EC. The Host writing a one to this bit can also clear this bit. The EC must generate the associated SCI interrupt under software control.	R/WC (Note 1)	00h	RESET_SYS		

Note 1: These bits are set/cleared by the EC directly i.e., writing '1' sets the bit and writing '0' clears it. These bits can also be cleared by the Host software writing a one to this bit position and by [RESET_SYS](#). Writing a 0 by the Host has no effect.

14.11.3 POWER MANAGEMENT 1 ENABLE 1 REGISTER

Offset	02h	Bits	Description	Type	Default	Reset Event
7:0	Reserved			RES	-	-

14.11.4 POWER MANAGEMENT 1 ENABLE 2 REGISTER

Offset	03h			
Bits	Description	Type	Default	Reset Event
7:3	Reserved	RES	-	-
2	RTC_EN This bit can be read or written by the Host. It can be read by the EC.	R/W (Note 1)	00h	RESET_SYS
1	SLPBTN_EN This bit can be read or written by the Host. It can be read by the EC.	R/W (Note 1)	00h	RESET_SYS
0	PWRBTN_EN This bit can be read or written by the Host. It can be read by the EC.	R/W (Note 1)	00h	RESET_SYS

Note 1: These bits are read-only by the EC.

14.11.5 POWER MANAGEMENT 1 CONTROL 1 REGISTER

Offset	04h			
Bits	Description	Type	Default	Reset Event
7:0	Reserved	RES	0h	RESET_SYS

14.11.6 POWER MANAGEMENT 1 CONTROL 2 REGISTER

Offset	05h			
Bits	Description	Type	Default	Reset Event
7:6	Reserved	RES	-	-
5	SLP_EN See Table 14-7 .	See Table 14-7 .	00h	RESET_SYS
4:2	SLP_TYP These bits can be set or cleared by the Host, read by the EC.	R/W (Note 1)	00h	RESET_SYS
1	PWRBTNOR_EN This bit can be set or cleared by the Host, read by the EC.	R/W (Note 1)	00h	RESET_SYS
0	Reserved	RES	-	-

Note 1: These bits are read-only by the EC.

TABLE 14-7: SLP_EN DEFINITION

Host / EC	R/W	Description
Host	Read	Always reads 0
	Write	Writing a 0 has no effect, Writing a 1 sets this bit
EC	Read	Reads the value of the bit
	Write	Writing a 0 has no effect, Writing a 1 clears this bit

MEC1725

14.11.7 POWER MANAGEMENT 2 CONTROL 1 REGISTER

Offset	06h			
Bits	Description	Type	Default	Reset Event
7:0	Reserved	RES	-	-

14.11.8 POWER MANAGEMENT 2 CONTROL 2 REGISTER

Offset	07h			
Bits	Description	Type	Default	Reset Event
7:0	Reserved	RES	-	-

14.12 EC Registers

Registers for this block are shown in the following summary table. Addresses for each register are determined by adding the offset to the Base Address for each instance of the [ACPI PM1 Block](#) Block in the Block Overview and Base Address Table in [Section 3.0, "Device Inventory"](#).

TABLE 14-8: REGISTER SUMMARY

Offset	Register Name
100h	Power Management 1 Status 1 Register
101h	Power Management 1 Status 2 Register
102h	Power Management 1 Enable 1 Register
103h	Power Management 1 Enable 2 Register
104h	Power Management 1 Control 1 Register
105h	Power Management 1 Control 2 Register
106h	Power Management 2 Control 1 Register
107h	Power Management 2 Control 2 Register
110h	EC_PM_STS Register

Note: The Power Management Status, Enable and Control registers in [Table 14-8, "Register Summary"](#) are described in [Section 14.11, "Runtime Registers"](#).

14.12.1 EC_PM_STS REGISTER

Offset	110h			
Bits	Description	Type	Default	Reset Event
7:1	UD	R/W	00h	RESET_SYS
0	EC_SCI_STS If the EC_SCI_STS bit is "1", an interrupt is generated on the nEC_SCI pin.	R/W	00h	RESET_SYS

Note: This register is only accessed by the EC. There is no host access to this register.

15.0 EMBEDDED MEMORY INTERFACE (EMI)

15.1 Introduction

The [Embedded Memory Interface \(EMI\)](#) provides a standard run-time mechanism for the system host to communicate with the Embedded Controller (EC) and other logical components. The Embedded Memory Interface includes 13 byte-addressable registers in the Host's address space, as well as 22 bytes of registers that are accessible only by the EC. The Embedded Memory Interface can be used by the Host to access bytes of memory designated by the EC without requiring any assistance from the EC. The EC may configure these regions of memory as read-only, write-only, or read/write capable.

15.2 Interface

This block is designed to be accessed externally via pin interface and internally via a register interface.

FIGURE 15-1: I/O DIAGRAM OF BLOCK

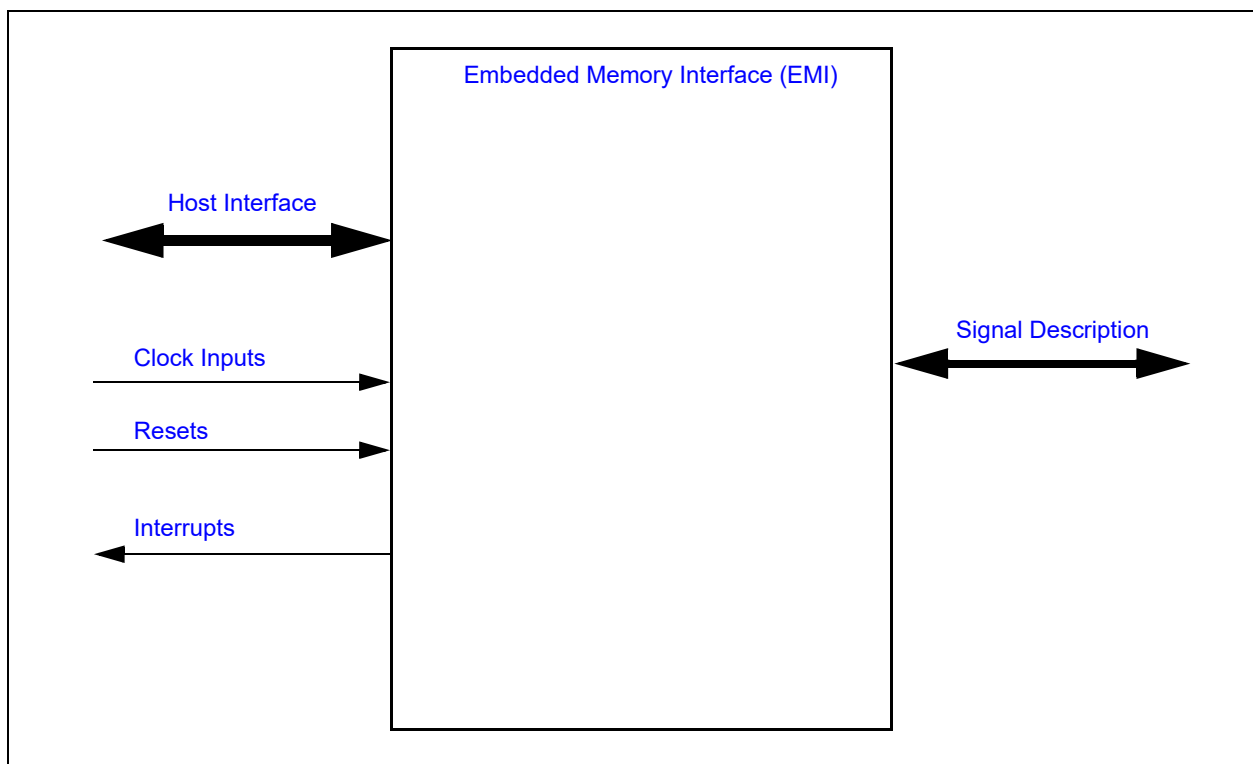

15.3 Signal Description

Name	Name	Description
nEMI_INT	OUTPUT	Active-low signal asserted when either the EC-to-Host or the Host_SWI_Event is asserted. This signal can be routed to nSMI and nPME inputs in the system as required.

15.4 Host Interface

The registers defined for the [Embedded Memory Interface \(EMI\)](#) are accessible by the various hosts as indicated in [Section 3.2, "Block Overview and Base Addresses"](#).

MEC1725

15.5 Power, Clocks and Reset

This section defines the Power, Clock, and Reset parameters of the block.

15.5.1 POWER DOMAINS

TABLE 15-1: POWER SOURCES

Name	Description
VTR_CORE	The logic and registers implemented in this block reside on this single power well.

15.5.2 CLOCK INPUTS

This block has no special clocking requirements. Host register accesses are synchronized to the host bus clock and EC register accesses are synchronized to the EC bus clock, thereby allowing the transactions to complete in one bus clock.

15.5.3 RESETS

TABLE 15-2: RESET SIGNALS

Name	Description
RESET_SYS	This reset signal resets all the logic and register in this block.

15.6 Interrupts

This section defines the Interrupt Sources generated from this block.

TABLE 15-3: SYSTEM INTERRUPTS

Source	Description
Host_SWI_Event	This interrupt source for the SERIRQ logic is generated when any of the EC_SWI bits are asserted and the corresponding EC_SWI_EN bits are asserted as well. This event is also asserted if the embedded controller (EC) writes the EC-to-HOST Mailbox Register .
EC-to-Host	This interrupt source for the SERIRQ logic is generated by the embedded controller (EC) writing the EC-to-HOST Mailbox Register .

TABLE 15-4: EC INTERRUPTS

Source	Description
Host-to-EC	Interrupt source for the Interrupt Aggregator, generated by the host writing the HOST-to-EC Mailbox Register .

15.7 Low Power Modes

The [Embedded Memory Interface \(EMI\)](#) automatically enters low power mode when no transaction target it.

15.8 Description

FIGURE 15-2: EMBEDDED MEMORY INTERFACE BLOCK DIAGRAM

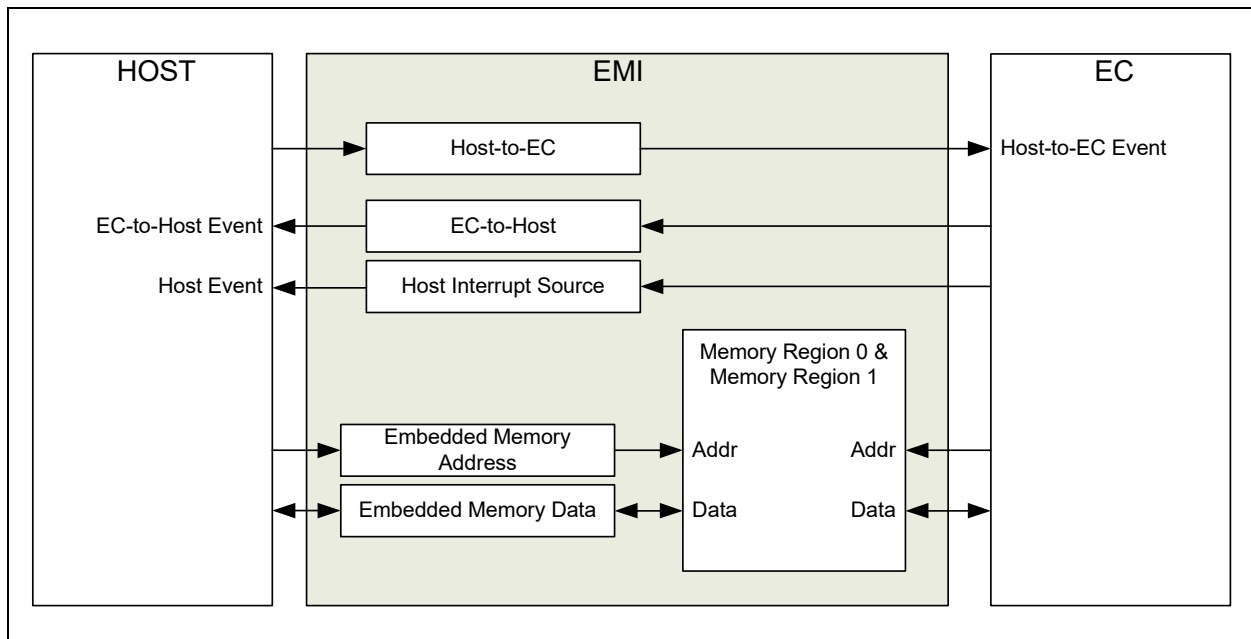

The Embedded Memory Interface (EMI) is composed of a mailbox, a direct memory interface, and an Application ID register.

The mailbox contains two registers, the [HOST-to-EC Mailbox Register](#) and the [EC-to-HOST Mailbox Register](#), that act as a communication portal between the system host and the embedded controller. When the [HOST-to-EC Mailbox Register](#) is written an interrupt is generated to the embedded controller. Similarly, when the [EC-to-HOST Mailbox Register](#) is written an interrupt is generated to the system host. The source of the system host interrupt may be read in the Interrupt Source Register. These interrupt events may be individually prevented from generating a Host Event via the Interrupt Mask Register.

The direct memory interface, which is composed of a byte addressable 16-bit EC Address Register and a 32-bit EC Data Register, permits the Host to read or write a portion of the EC's internal address space. The embedded controller may enable up to two regions of the EC's internal address space to be exposed to the system host. The system host may access these memory locations without intervention or assistance from the EC.

The Embedded Memory Interface can be configured so that data transfers between the Embedded Memory Interface data bytes and the 32-bit internal address space may be multiple bytes, while Host I/O is always executed a byte at a time.

When the Host reads one of the four bytes in the Embedded Memory Interface data register, data from the internal 32-bit address space, at the address defined by the Embedded Memory Interface address register, is returned to the Host. This read access will load 1, 2, or 4 bytes into the Data register depending on the configuration of the [ACCESS_TYPE](#) bits. Similarly, writing one of the four bytes in the data register will write the corresponding byte(s) from the data register into the internal 32-bit address space as indicated by the [ACCESS_TYPE](#) bits. This configuration option is done to ensure that data the EC treats as 16-bit or 32-bit will be consistent in the Host, even though one byte of the data may change between two or more 8-bit accesses by the Host.

In addition, there is an auto-increment function for the Embedded Memory Interface address register. When enabled, the Host can read or write blocks of memory in the 32-bit internal address space by repeatedly accessing the Embedded Memory Interface data register, without requiring Host updates to the Embedded Memory Interface address register.

Finally, the [Application ID Register](#) may be used by the host to provide an arbitration mechanism if more than one software thread requires access through the EMI interface. See [Section 15.8.4, "Embedded Memory Interface Usage"](#) for more details.

MEC1725

15.8.1 EMBEDDED MEMORY MAP

Each Embedded Memory interface provides direct access for the Host into two windows in the EC 32-bit internal address space. This mapping is shown in Figure 15-3, "Embedded Memory Addressing":

FIGURE 15-3: EMBEDDED MEMORY ADDRESSING

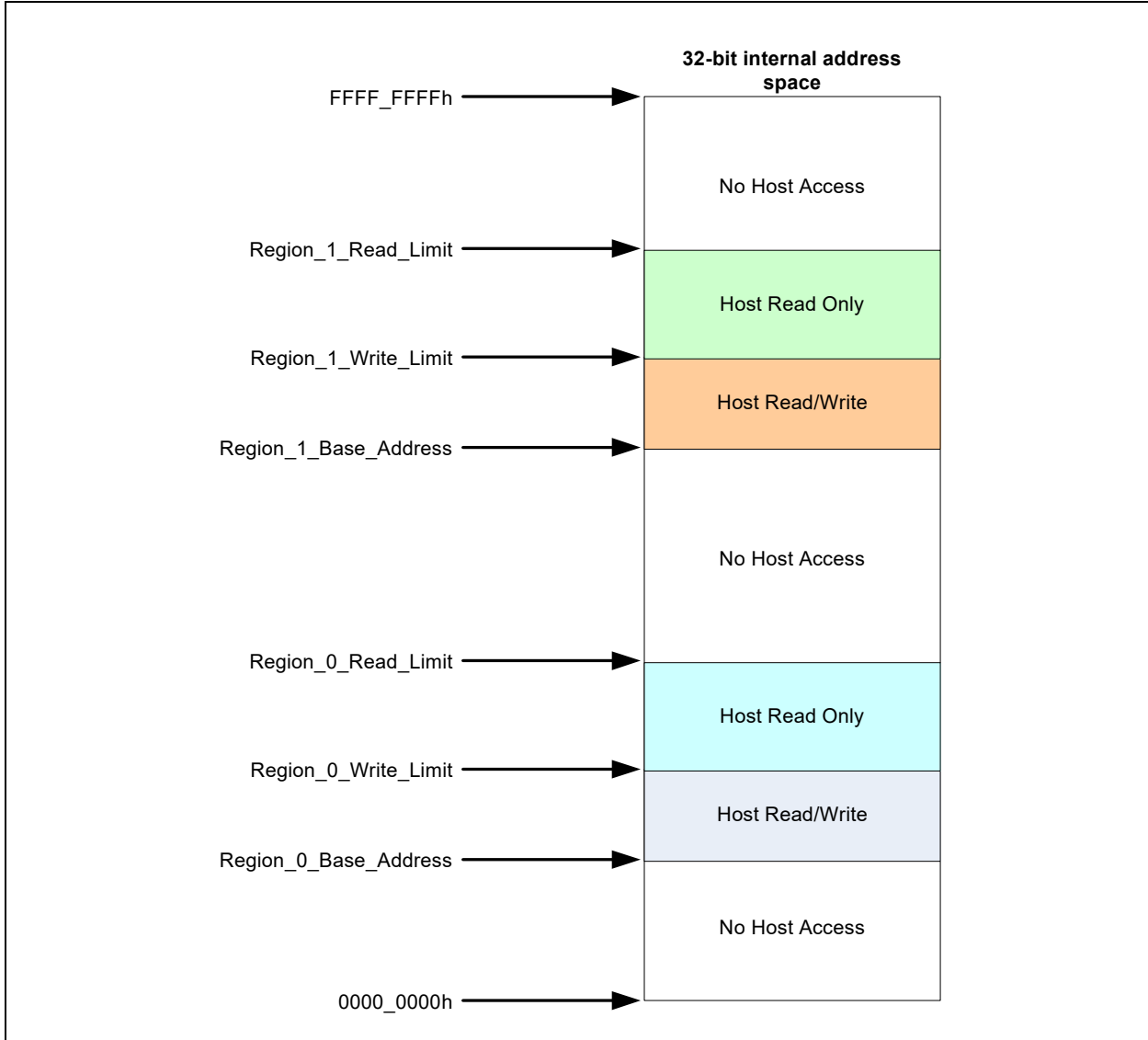

The Base addresses, the Read limits and the Write limits are defined by registers that are in the EC address space and cannot be accessed by the Host. In each region, the Read limit need not be greater than the Write limit. The regions can be contiguous or overlapping. For example, if the Region 0 Read limit is set to 0 and the Write limit is set to a positive number, then the Embedded Memory interface defines a region in the EC memory that the EC can read and write but is write-only for the host. This might be useful for storage of security data, which the Host might wish to send to the EC but should not be readable in the event a virus invades the Host.

Each window into the EC memory can be as large as 32k bytes in the 32-bit internal address space.

15.8.2 EC DATA REGISTER

The 4 1-byte EC Data Byte registers function as a 32-bit register, which creates a 4 byte window into the Memory REGION being accessed. The 4-byte window is always aligned on a 4-byte boundary. Depending on the read/write configuration of the memory region being accessed, the bytes may be extracted from or loaded into memory as a byte, word, or a DWORD. The ACCESS_TYPE determines the size of the memory access. The address accessed is determined by the two EC_Address byte registers, which together function as a 15-bit EC Address Register.

- A write to the EC Data Register when the EC Address is in a read-only or a no-access region, as defined by the Memory Base and Limit registers, will update the EC Data Register but memory will not be modified.
- A read to the EC Data Register when the EC Address is in a no-access region, as defined by the Memory Base and Limit registers, will not trigger a memory read and will not modify the EC Data Register. In auto-increment mode (ACCESS_TYPE=11b), reads of Byte 3 of the EC Data Register will still trigger increments of the EC Address Register when the address is out of bounds, while writes of Byte 3 will not.

15.8.3 ACCESS TYPES

The access type field (ACCESS_TYPE in the EC Address LSB Register) defines the type of host access that occurs when the EC Data Register is read or written.

- 11: Auto-increment 32-bit access. This defines a 32-bit access, as in the 10 case. In addition, any read or write of Byte 3 in the EC Data Register causes the EC Data Register to be incremented by 1. That is, the EC_Address field will point to the next 32-bit double word in the 32-bit internal address space.
- 10: 32-bit access. A read of Byte 0 in the EC Data Register causes the 32 bits in the 32-bit internal address space at an offset of EC_Address to be loaded into the entire EC Data Register. The read then returns the contents of Byte 0. A read of Byte 1, Byte 2 or Byte 3 in the EC Data Register returns the contents of the register, without any update from the 32-bit internal address space.

A write of Byte 3 in the EC Data Register causes the EC Data Register to be written into the 32 bits in the 32-bit internal address space at an offset of EC_Address. A write of Byte 0, Byte 1 or Byte 2 in the EC Data Register updates the contents of the register, without any change to the 32-bit internal address space.

- 01: 16-bit access. A read of Byte 0 in the EC Data Register causes the 16 bits in the 32-bit internal address space at an offset of EC_Address to be loaded into Byte 0 and Byte 1 of the EC Data Register. The read then returns the contents of Byte 0. A read of Byte 2 in the EC Data Register causes the 16 bits in the 32-bit internal address space at an offset of EC_Address+2 to be loaded into Byte 2 and Byte 3 of the EC Data Register. The read then returns the contents of Byte 2. A read of Byte 1 or Byte 3 in the EC Data Register return the contents of the register, without any update from the 32-bit internal address space.

A write of Byte 1 in the EC Data Register causes Bytes 1 and 0 of the EC Data Register to be written into the 16 bits in the 32-bit internal address space at an offset of EC_Address. A write of Byte 3 in the EC Data Register causes Bytes 3 and 2 of the EC Data Register to be written into the 16 bits in the 32-bit internal address space at an offset of EC_Address+2. A write of Byte 0 or Byte 2 in the EC Data Register updates the contents of the register, without any change to the 32-bit internal address space.

- 00: 8-bit access. Any byte read of Byte 0 through Byte 3 in the EC Data Register causes the corresponding byte within the 32-bit double word addressed by EC_Address to be loaded into the byte of EC Data Register and returned by the read. Any byte write to Byte 0 through Byte 3 in the EC Data Register writes the corresponding byte within the 32-bit double word addressed by EC_Address, as well as the byte of the EC Data Register.

15.8.4 EMBEDDED MEMORY INTERFACE USAGE

The Embedded Memory Interface provides a generic facility for communication between the Host and the EC and can be used for many functions. Some examples are:

- Virtual registers. A block of memory in the 32-bit internal address space can be used to implement a set of virtual registers. The Host is given direct read-only access to this address space, referred to as peek mode. The EC may read or write this memory as needed.
- Program downloading. Because the Instruction Closely Coupled Memory is implemented in the same 32-bit internal address space, the Embedded Memory Interface can be used by the Host to download new program segments for the EC in the upper 32KB SRAM. The Read/Write window would be configured by the Host to point to the beginning of the loadable program region, which could then be loaded by the Host.
- Data exchange. The Read/Write portion of the memory window can be used to contain a communication packet. The Host, by default, "owns" the packet, and can write it at any time. When the Host wishes to communicate with the EC, it sends the EC a command, through the Host-to-EC message facility, to read the packet and perform

some operations as a result. When it is completed processing the packet, the EC can inform the Host, either through a message in the EC-to-Host channel or by triggering an event such as an SMI directly. If return results are required, the EC can write the results into the Read/Write region, which the Host can read directly when it is informed that the EC has completed processing. Depending on the command, the operations could entail update of virtual registers in the 32-bit internal address space, reads of any register in the EC address space, or writes of any register in the EC address space. Because there are two regions that are defined by the base registers, the memory used for the communication packet does not have to be contiguous with a set of virtual registers.

Because there are two Embedded Memory Interface memory regions, the Embedded Memory Interface cannot be used for more than two of these functions at a time. The Host can request that the EC switch from one function to another through the use of the Host-to-EC mailbox register.

The [Application ID Register](#) is provided to help software applications track ownership of an Embedded Memory Interface. An application can write the register with its Application ID, then immediately read it back. If the read value is not the same as the value written, then another application has ownership of the interface.

Note: The protocol used to pass commands back and forth through the Embedded Memory Interface Registers Interface is left to the System designer. Microchip can provide an application example of working code in which the host uses the Embedded Memory Interface registers to gain access to all of the EC registers.

15.9 Application ID Assignment and Status register

The Application ID assignment mechanism described in this section is used for dynamically allocating Application ID. The status register available to the host allows the EC to monitor/manage the application ID usage of the system. Application ID "0x0" is not used. So a maximum of 255 Application ID's are available to the users. As the host applications request for Application ID by reading the Application ID Assignment register, hardware keep allocating the Application ID in incremental manner and keep toggling the respective Application ID status registers status bit to "1". As each application finishes its execution, it writes back its application ID into the Application ID assignment register and this frees the corresponding application ID resulting in the corresponding Application ID Status value becoming "0".

New application may now use the freed up Application ID values. The EMI block checks for the free application ID status bit and allocates this application ID value to the requesting application and toggles the corresponding Application ID status bit to "1". If the Application ID is not available the value of "0x0" will be returned to the application reading the "Application ID Assignment" register. The requesting application may read the "Application ID" register (retry application ID allocation) after some time.

Accidental register address sweep will create an unused Application ID. EC may monitor the Semaphores using the "8", 32 bit Application ID status registers and find the semaphores that are accidentally created and terminate them and reset the appropriate bits in the "8", 32 bit [Application ID Status Register](#). A time based Application ID monitoring scheme may also be used by application FW to figure out stuck threads.

15.10 Runtime Registers

The registers listed in the Runtime Register Summary table are for a single instance of the [Embedded Memory Interface \(EMI\)](#). Host access for each register listed in this table is defined as an offset in the Host address space to the EMI Block's Base Address, as defined by the instance's Base Address Register.

The EC address for each register is formed by adding the Base Address for each instance of the [Embedded Memory Interface \(EMI\)](#) shown in the Block Overview and Base Address Table in [Section 3.0, "Device Inventory"](#) to the offset shown in the "Offset" column.

The [Embedded Memory Interface \(EMI\)](#) can be accessed from the eSPI Host Interface, the ESPI Host Interface, or the internal embedded controller (EC). The following table summarizes the host access types supported for each interface.

TABLE 15-5: RUNTIME REGISTER SUMMARY

Offset	Register Name
00h	HOST-to-EC Mailbox Register
01h	EC-to-HOST Mailbox Register

TABLE 15-5: RUNTIME REGISTER SUMMARY

Offset	Register Name
02h	EC Address LSB Register
03h	EC Address MSB Register
04h	EC Data Byte 0 Register
05h	EC Data Byte 1 Register
06h	EC Data Byte 2 Register
07h	EC Data Byte 3 Register
08h	Interrupt Source LSB Register
09h	Interrupt Source MSB Register
0Ah	Interrupt Mask LSB Register
0Bh	Interrupt Mask MSB Register
0Ch	Application ID Register
10h	Application ID Assignment Register

15.10.1 HOST-TO-EC MAILBOX REGISTER

Offset	00h			
Bits	Description	Type	Default	Reset Event
7:0	<p>HOST_EC_MBOX 8-bit mailbox used communicate information from the system host to the embedded controller. Writing this register generates an event to notify the embedded controller.</p> <p>The embedded controller has the option of clearing some or all of the bits in this register. This is dependent on the protocol layer implemented using the EMI Mailbox. The host must know this protocol to determine the meaning of the value that will be reported on a read.</p> <p>This bit field is aliased to the HOST_EC_MBOX bit field in the HOST-to-EC Mailbox Register</p>	R/W	0h	RESET_SYS

15.10.2 EC-TO-HOST MAILBOX REGISTER

Offset	01h			
Bits	Description	Type	Default	Reset Event
7:0	<p>EC_HOST_MBOX 8-bit mailbox used communicate information from the embedded controller to the system host. Writing this register generates an event to notify the system host.</p> <p>The system host has the option of clearing some or all of the bits in this register. This is dependent on the protocol layer implemented using the EMI Mailbox. The embedded controller must know this protocol to determine the meaning of the value that will be reported on a read.</p> <p>This bit field is aliased to the EC_HOST_MBOX bit field in the EC-to-HOST Mailbox Register</p>	R/WC	0h	RESET_SYS

MEC1725

15.10.3 EC ADDRESS LSB REGISTER

Offset	02h			
Bits	Description	Type	Default	Reset Event
7:2	<p>EC_ADDRESS_LSB This field defines bits[7:2] of EC_Address [15:0]. Bits[1:0] of the EC_Address are always forced to 00b.</p> <p>The EC_Address is aligned on a DWord boundary. It is the address of the memory being accessed by EC Data Byte 0 Register, which is an offset from the programmed base address of the selected REGION.</p>	R/W	0h	RESET_SYS
1:0	<p>ACCESS_TYPE This field defines the type of access that occurs when the EC Data Register is read or written.</p> <p>11b=Auto-increment 32-bit access. 10b=32-bit access. 01b=16-bit access. 00b=8-bit access.</p> <p>Each of these access types are defined in detail in Section 15.8.3, "Access Types".</p>	R/W	0h	RESET_SYS

15.10.4 EC ADDRESS MSB REGISTER

Offset	03h			
Bits	Description	Type	Default	Reset Event
7	<p>REGION The field specifies which of two segments in the 32-bit internal address space is to be accessed by the EC_Address[14:2] to generate accesses to the memory.</p> <p>1=The address defined by EC_Address[14:2] is relative to the base address specified by the Memory Base Address 1 Register. 0=The address defined by EC_Address[14:2] is relative to the base address specified by the Memory Base Address 0 Register.</p>	R/W	0h	RESET_SYS
6:0	<p>EC_ADDRESS_MSB This field defines bits[14:8] of EC_Address. Bits[1:0] of the EC_Address are always forced to 00b.</p> <p>The EC_Address is aligned on a DWord boundary. It is the address of the memory being accessed by EC Data Byte 0 Register, which is an offset from the programmed base address of the selected REGION.</p>	R/W	0h	RESET_SYS

15.10.5 EC DATA BYTE 0 REGISTER

Offset	04h			
Bits	Description	Type	Default	Reset Event
7:0	<p>EC_DATA_BYTE_0</p> <p>This is byte 0 (Least Significant Byte) of the 32-bit EC Data Register.</p> <p>Use of the Data Byte registers to access EC memory is defined in detail in Section 15.8.2, "EC Data Register".</p>	R/W	0h	RESET_SYS

15.10.6 EC DATA BYTE 1 REGISTER

Offset	05h			
Bits	Description	Type	Default	Reset Event
7:0	<p>EC_DATA_BYTE_1</p> <p>This is byte 1 of the 32-bit EC Data Register.</p> <p>Use of the Data Byte registers to access EC memory is defined in detail in Section 15.8.2, "EC Data Register".</p>	R/W	0h	RESET_SYS

15.10.7 EC DATA BYTE 2 REGISTER

Offset	06h			
Bits	Description	Type	Default	Reset Event
7:0	<p>EC_DATA_BYTE_2</p> <p>This is byte 2 of the 32-bit EC Data Register.</p> <p>Use of the Data Byte registers to access EC memory is defined in detail in Section 15.8.2, "EC Data Register".</p>	R/W	0h	RESET_SYS

15.10.8 EC DATA BYTE 3 REGISTER

Offset	07h			
Bits	Description	Type	Default	Reset Event
7:0	<p>EC_DATA_BYTE_3</p> <p>This is byte 3 (Most Significant Byte) of the 32-bit EC Data Register.</p> <p>Use of the Data Byte registers to access EC memory is defined in detail in Section 15.8.2, "EC Data Register".</p>	R/W	0h	RESET_SYS

MEC1725

15.10.9 INTERRUPT SOURCE LSB REGISTER

Offset	08h			
Bits	Description	Type	Default	Reset Event
7:1	<p>EC_SWI_LSB</p> <p>EC Software Interrupt Least Significant Bits. These bits are software interrupt bits that may be set by the EC to notify the host of an event. The meaning of these bits is dependent on the firmware implementation.</p> <p>Each bit in this field is cleared when written with a '1b'. The ability to clear the bit can be disabled by the EC if the corresponding bit in the Host Clear Enable Register is set to '0b'. This may be used by firmware for events that cannot be cleared while the event is still active.</p>	R/WC	0h	RESET_SYS
0	<p>EC_WR</p> <p>EC Mailbox Write. This bit is set when the EC-to-HOST Mailbox Register has been written by the EC at offset 01h of the EC-Only registers.</p> <p>Note: there is no corresponding mask bit in the Interrupt Mask LSB Register.</p>	R	0h	RESET_SYS

15.10.10 INTERRUPT SOURCE MSB REGISTER

Offset	09h			
Bits	Description	Type	Default	Reset Event
7:0	<p>EC_SWI_MSB</p> <p>EC Software Interrupt Most Significant Bits. These bits are software interrupt bits that may be set by the EC to notify the host of an event. The meaning of these bits is dependent on the firmware implementation.</p> <p>Each bit in this field is cleared when written with a '1b'. The ability to clear the bit can be disabled by the EC. if the corresponding bit in the Host Clear Enable Register is set to '0b'. This may be used by firmware for events that cannot be cleared while the event is still active.</p>	R/WC	0h	RESET_SYS

15.10.11 INTERRUPT MASK LSB REGISTER

Offset	0Ah			
Bits	Description	Type	Default	Reset Event
7:1	<p>EC_SWI_EN_LSB</p> <p>EC Software Interrupt Enable Least Significant Bits. Each bit that is set to '1b' in this field enables the generation of a Host Event interrupt by the corresponding bit in the EC_SWI field in the Interrupt Source LSB Register.</p>	R/W	0h	RESET_SYS
0	TEST	R/W	0h	RESET_SYS

15.10.12 INTERRUPT MASK MSB REGISTER

Offset	0Bh			
Bits	Description	Type	Default	Reset Event
7:0	EC_SWI_EN_MSB EC Software Interrupt Enable Most Significant Bits. Each bit that is set to '1b' in this field enables the generation of a Host Event interrupt by the corresponding bit in the EC_SWI field in the Interrupt Source MSB Register .	R/W	0h	RESET_SYS

15.10.13 APPLICATION ID REGISTER

Offset	0Ch			
Bits	Description	Type	Default	Reset Event
7:0	APPLICATION_ID When this field is 00h it can be written with any value. When set to a non-zero value, writing that value will clear this register to 00h. When set to a non-zero value, writing any value other than the current contents will have no effect.	R/W	0h	RESET_SYS

15.10.14 APPLICATION ID ASSIGNMENT REGISTER

Offset	10h			
Bits	Description	Type	Default	Reset Event
7:0	APPLICATION_ID_ASSIGNMENT Reading the Application ID Assignment register, allocates the next available Application ID. The application ID of 0x0 is not used and signifies free application ID's are not available. The Host/EC should try after some time	R/W	0h	RESET_SYS

15.11 EC Registers

Registers for this block are shown in the following summary table. Addresses for each register are determined by adding the offset to the Base Address for each instance of the [Embedded Memory Interface \(EMI\)](#) Block in the Block Overview and Base Address Table in [Section 3.0, "Device Inventory"](#).

TABLE 15-6: EC-ONLY REGISTER SUMMARY

Offset	Register Name
100h	HOST-to-EC Mailbox Register
101h	EC-to-HOST Mailbox Register
104h	Memory Base Address 0 Register
108h	Memory Read Limit 0 Register
10Ah	Memory Write Limit 0 Register
10Ch	Memory Base Address 1 Register
110h	Memory Read Limit 1 Register
112h	Memory Write Limit 1 Register
114h	Interrupt Set Register

MEC1725

TABLE 15-6: EC-ONLY REGISTER SUMMARY

Offset	Register Name
116h	Host Clear Enable Register
120h	Host Clear Enable Register

15.11.1 HOST-TO-EC MAILBOX REGISTER

Offset	100h			
Bits	Description	Type	Default	Reset Event
7:0	<p>HOST_EC_MBOX</p> <p>8-bit mailbox used communicate information from the system host to the embedded controller. Writing this register generates an event to notify the embedded controller.</p> <p>The embedded controller has the option of clearing some or all of the bits in this register. This is dependent on the protocol layer implemented using the EMI Mailbox. The host must know this protocol to determine the meaning of the value that will be reported on a read.</p> <p>This bit field is aliased to the HOST_EC_MBOX bit field in the HOST-to-EC Mailbox Register.</p>	R/WC	0h	RESET_SYS

15.11.2 EC-TO-HOST MAILBOX REGISTER

Offset	01h			
Bits	Description	Type	Default	Reset Event
7:0	<p>EC_HOST_MBOX</p> <p>8-bit mailbox used communicate information from the embedded controller to the system host. Writing this register generates an event to notify the system host.</p> <p>The system host has the option of clearing some or all of the bits in this register. This is dependent on the protocol layer implemented using the EMI Mailbox. The embedded controller must know this protocol to determine the meaning of the value that will be reported on a read.</p> <p>This bit field is aliased to EC_HOST_MBOX bit field in the EC-to-HOST Mailbox Register.</p>	R/W	0h	RESET_SYS

15.11.3 MEMORY BASE ADDRESS 0 REGISTER

Offset	104h			
Bits	Description	Type	Default	Reset Event
31:2	MEMORY_BASE_ADDRESS_0 This memory base address defines the beginning of region 0 in the Embedded Controller's 32-bit internal address space. Memory allocated to region 0 is intended to be shared between the Host and the EC. The region defined by this base register is used when bit 15 of the EC Address Register is 0. The access will be to a memory location at an offset defined by the EC_Address relative to the beginning of the region defined by this register. Therefore, a read or write to the memory that is triggered by the EC Data Register will occur at Memory_Base_Address_0 + EC_Address.	R/W	0h	RESET_SYS
1:0	Reserved	RES	-	-

15.11.4 MEMORY READ LIMIT 0 REGISTER

Offset	108h			
Bits	Description	Type	Default	Reset Event
15	Reserved	RES	-	-
14:2	MEMORY_READ_LIMIT_0 Whenever a read of any byte in the EC Data Register is attempted, and bit 15 of EC_Address is 0, the field EC_Address[14:2] in the EC_Address_Register is compared to this field. As long as EC_Address[14:2] is less than this field the EC_Data_Register will be loaded from the 32-bit internal address space.	R/W	0h	RESET_SYS
1:0	Reserved	RES	-	-

15.11.5 MEMORY WRITE LIMIT 0 REGISTER

Offset	10Ah			
Bits	Description	Type	Default	Reset Event
15	Reserved	RES	-	-
14:2	MEMORY_WRITE_LIMIT_0 Whenever a write of any byte in EC DATA Register is attempted and bit 15 of EC_Address is 0, the field EC_ADDRESS_MSB in the EC_Address_Register is compared to this field. As long as EC_Address[14:2] is less than Memory_Write_Limit_0[14:2] the addressed bytes in the EC DATA Register will be written into the internal 32-bit address space. If EC_Address[14:2] is greater than or equal to the Memory_Write_Limit_0[14:2] no writes will take place.	R/W	0h	RESET_SYS
1:0	Reserved	RES	-	-

MEC1725

15.11.6 MEMORY BASE ADDRESS 1 REGISTER

Offset	10Ch			
Bits	Description	Type	Default	Reset Event
31:2	MEMORY_BASE_ADDRESS_1 This memory base address defines the beginning of region 1 in the Embedded Controller's 32-bit internal address space. Memory allocated to region 1 is intended to be shared between the Host and the EC. The region defined by this base register is used when bit 15 of the EC Address Register is 1. The access will be to a memory location at an offset defined by the EC_Address relative to the beginning of the region defined by this register. Therefore, a read or write to the memory that is triggered by the EC Data Register will occur at Memory_Base_Address_1 + EC_Address.	R/W	0h	RESET_SYS
1:0	Reserved	RES	-	-

15.11.7 MEMORY READ LIMIT 1 REGISTER

Offset	110h			
Bits	Description	Type	Default	Reset Event
15	Reserved	RES	-	-
14:2	MEMORY_READ_LIMIT_1 Whenever a read of any byte in the EC Data Register is attempted, and bit 15 of EC_ADDRESS is 1, the field EC_ADDRESS in the EC_Address_Register is compared to this field. As long as EC_ADDRESS is less than this value, the EC_Data_Register will be loaded from the 32-bit internal address space.	R/W	0h	RESET_SYS
1:0	Reserved	RES	-	-

15.11.8 MEMORY WRITE LIMIT 1 REGISTER

Offset	112h			
Bits	Description	Type	Default	Reset Event
15	Reserved	RES	-	-
14:2	MEMORY_WRITE_LIMIT_1 Whenever a write of any byte in EC DATA Register is attempted and bit 15 of EC_Address is 1, the field EC_Address[14:2] in the EC_Address_Register is compared to this field. As long as EC_Address[14:2] is less than Memory_Write_Limit_1[14:2] the addressed bytes in the EC DATA Register will be written into the internal 32-bit address space. If EC_Address[14:2] is greater than or equal to the Memory_Write_Limit_1[14:2] no writes will take place.	R/W	0h	RESET_SYS
1:0	Reserved	RES	-	-

15.11.9 INTERRUPT SET REGISTER

Offset	114h			
Bits	Description	Type	Default	Reset Event
15:1	EC_SWI_SET EC Software Interrupt Set. This register provides the EC with a means of updating the Interrupt Source Registers. Writing a bit in this field with a '1b' sets the corresponding bit in the Interrupt Source Register to '1b'. Writing a bit in this field with a '0b' has no effect. Reading this field returns the current contents of the Interrupt Source Register.	R/WS	0h	RESET_SYS
0	Reserved	RES	-	-

15.11.10 HOST CLEAR ENABLE REGISTER

Offset	116h			
Bits	Description	Type	Default	Reset Event
15:1	HOST_CLEAR_ENABLE When a bit in this field is '0b', the corresponding bit in the Interrupt Source Register cannot be cleared by writes to the Interrupt Source Register. When a bit in this field is '1b', the corresponding bit in the Interrupt Source Register can be cleared when that register bit is written with a '1b'. These bits allow the EC to control whether the status bits in the Interrupt Source Register are based on an edge or level event.	R/W	0h	RESET_SYS
0	Reserved	RES	-	-

15.11.11 APPLICATION ID STATUS REGISTER

Offset	120h - 13Ch			
Bits	Description	Type	Default	Reset Event
255:1	APPLICATION_ID_STATUS Each bit in this register represents 1 application ID value, so in all the "8", 32 bit registers represent the status of 256 Application ID's. The status of each bit in this application ID register is represented as below 0 = Corresponding application ID is free/unallocated to any application 1 = Corresponding application ID is used/allocated to any application.	R/W	0h	RESET_SYS
0	Reserved	RES	-	-

16.0 MAILBOX INTERFACE

16.1 Overview

The Mailbox provides a standard run-time mechanism for the host to communicate with the Embedded Controller (EC)

16.2 Interface

This block is designed to be accessed externally via the pin interface and internally via registered host interface.

FIGURE 16-1: I/O DIAGRAM OF BLOCK

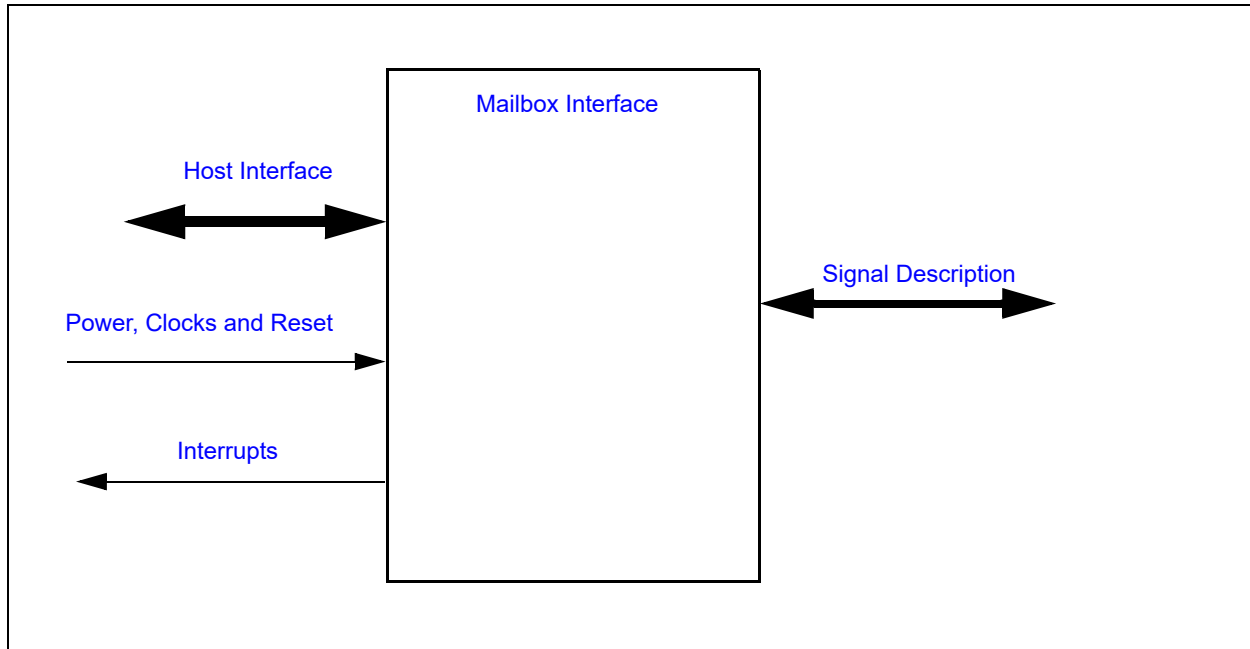

16.3 Signal Description

TABLE 16-1: SIGNAL DESCRIPTION TABLE

Name	Direction	Description
nSMI	OUTPUT	SMI alert signal to the Host.

16.4 Host Interface

The registers defined for [Mailbox Interface](#) is accessed by the various hosts as indicated in [Section 3.2, "Block Overview and Base Addresses"](#).

16.5 Power, Clocks and Reset

This section defines the Power, Clock, and Reset parameters of the block.

16.5.1 POWER DOMAINS

TABLE 16-2: POWER SOURCES

Name	Description
VTR_CORE	The logic and registers implemented in this block are powered by this power well.

16.5.2 CLOCK INPUTS

TABLE 16-3: CLOCK INPUTS

Name	Description
48MHz	This is the clock source for Mailbox logic.

16.5.3 RESETS

TABLE 16-4: RESET SIGNALS

Name	Description
RESET_SYS	This signal resets all the registers and logic in this block to their default state.
RESET_VCC	This signal is asserted when the main power rail is asserted. The Host Access Port is reset when this signal is de-asserted.

16.6 Interrupts

TABLE 16-5: SYSTEM INTERRUPTS

Source	Description
MBX_Host_SERIRQ	This interrupt source for the SERIRQ logic is generated when the EC_WR bit is '1' and enabled by the EC_WR_EN bit.
MBX_Host_SMI	This interrupt source for the SERIRQ logic is generated when any of the EC_SWI bits are asserted and the corresponding EC_SWI_EN bit are asserted as well. This event is also asserted if the EC_WR/EC_WR_EN event occurs as well. This bit is also routed to the nSMI pin.

TABLE 16-6: EC INTERRUPTS

Source	Description
MBX	Interrupt generated by the host writing the HOST-to-EC Mailbox register.

16.7 Low Power Modes

The Mailbox automatically enters a low power mode whenever it is not actively.

16.8 Description

FIGURE 16-2: MAILBOX BLOCK DIAGRAM

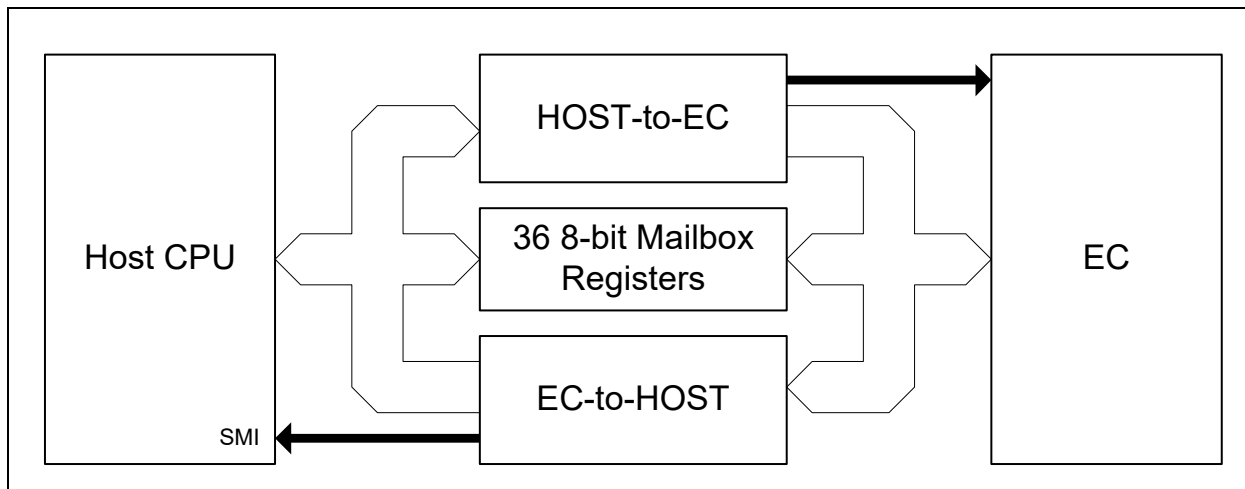

16.8.1 HOST ACCESS PORT

The Mailbox includes a total of 36 index-addressable 8-bit Mailbox registers and a two byte Mailbox Registers Host Access Port. Thirty-two of the 36 index-addressable 8-bit registers are EC Mailbox registers, which can be read and written by both the EC and the Host. The remaining four registers are used for signaling between the Host and the EC. The Host Access Port consists of two 8-bit run-time registers that occupy two addresses in the HOST I/O space, [MBX_INDEX Register](#) and [MBX_DATA Register](#). The Host Access Port is used by the host to access the 36 index-addressable 8-bit registers.

To access a Mailbox register once the Mailbox Registers Interface Base Address has been initialized, the Mailbox register index address is first written to the MBX Index port. After the Index port has been written, the Mailbox data byte can be read or written via the MBX data port.

The Host Access Port is intended to be accessed by the Host only, however it may be accessed by the EC at the Offset shown from its 32-bit internal address in [Table 16-7, "Runtime Register Summary"](#).

16.8.2 HOST INTERRUPT GENERATION

The Mailbox can generate a SERIRQ event for EC-to-HOST EC events, using the [EC-to-Host Mailbox Register](#). This interrupt is routed to the SERIRQ block.

The Mailbox can also generate an SMI event, using [SMI Interrupt Source Register](#). The SMI event can be routed to any frame in the SERIRQ stream as well as to the nSMI pin. The SMI event can be routed to nSMI pin by selecting the nSMI signal function in the associated GPIO Pin Control Register. The SMI event produces a standard active low frame on the serial IRQ stream and active low level on the open drain nSMI pin.

Routing for both the SERIRQ logic and the nSMI pin is shown in [Figure 16-3](#).

FIGURE 16-3: MAILBOX SERIRQ AND SMI ROUTING

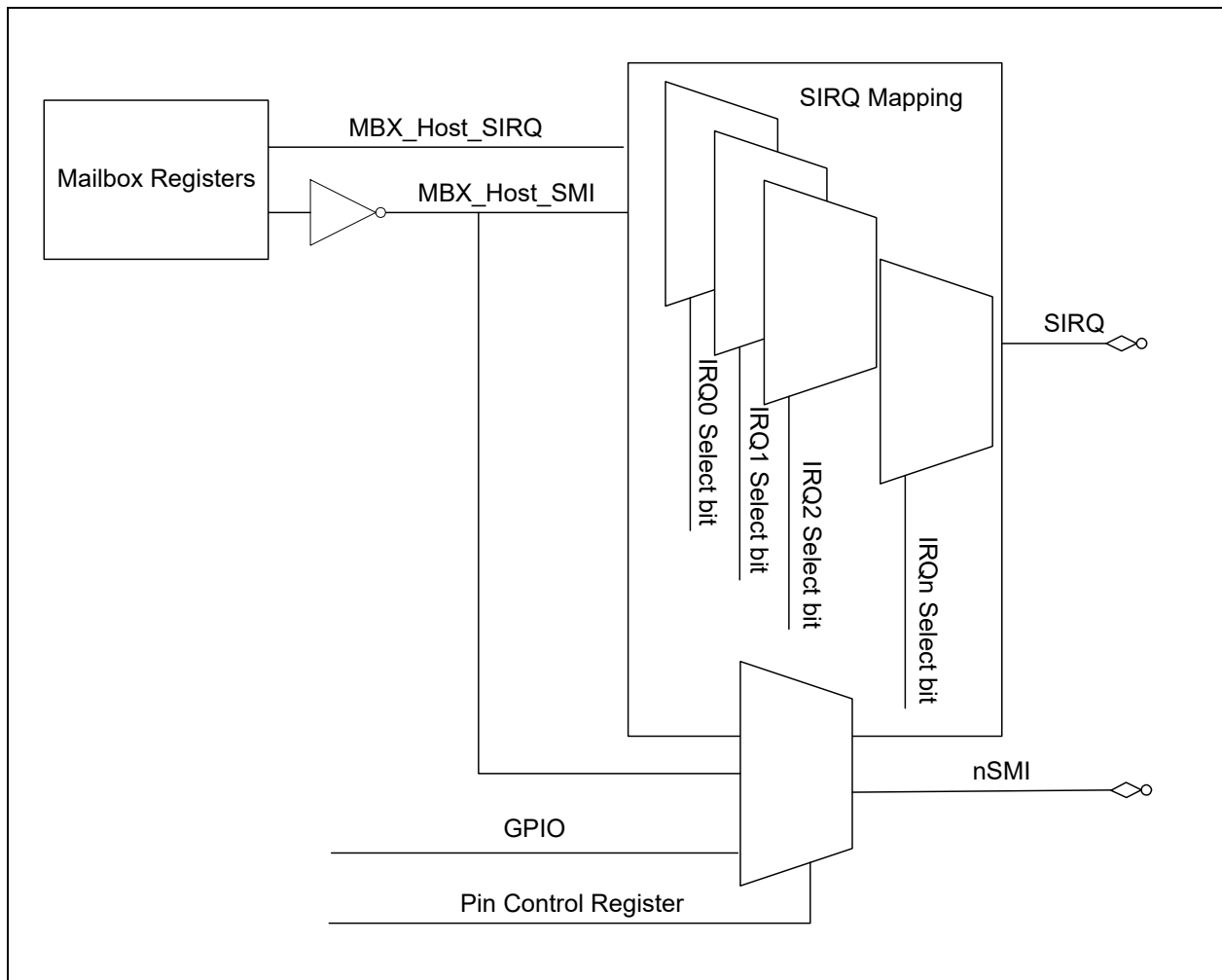

16.8.3 EC MAILBOX CONTROL

The [HOST-to-EC Mailbox Register](#) and [EC-to-Host Mailbox Register](#) are designed to pass commands between the host and the EC. If enabled, these registers can generate interrupts to both the Host and the EC.

The two registers are not dual-ported, so the HOST BIOS and Keyboard BIOS must be designed to properly share these registers. When the host performs a write of the [HOST-to-EC Mailbox Register](#), an interrupt will be generated and seen by the EC if unmasked. When the EC writes FFh to the Mailbox Register, the register resets to 00h, providing a simple means for the EC to inform the host that an operation has been completed.

When the EC writes the [EC-to-Host Mailbox Register](#), an SMI may be generated and seen by the host if unmasked. When the Host CPU writes FFh to the register, the register resets to 00h, providing a simple means for the host to inform that EC that an operation has been completed.

Note: The protocol used to pass commands back and forth through the Mailbox Registers Interface is left to the System designer. Microchip can provide an application example of working code in which the host uses the Mailbox registers to gain access to all of the EC registers.

MEC1725

16.9 Runtime Registers

The registers listed in the Runtime Register Summary table are for a single instance of the [Mailbox Interface](#). Host access for each register listed in this table is defined as an offset in the Host address space to the Block's Base Address, as defined by the instance's Base Address Register.

The EC address for each register is formed by adding the Base Address for the [Mailbox Interface](#) shown in the Block Overview and Base Address Table in [Section 3.0, "Device Inventory"](#) to the offset shown in the "Offset" column.

TABLE 16-7: RUNTIME REGISTER SUMMARY

Offset	Register Name
0h	MBX_INDEX Register
1h	MBX_DATA Register

16.9.1 MBX_INDEX REGISTER

Offset	0h			
Bits	Description	Type	Default	Reset Event
7:0	INDEX The index into the mailbox registers listed in Table 16-8, "Register Summary" .	R/W	0h	RESET_VCC

16.9.2 MBX_DATA REGISTER

Offset	01h			
Bits	Description	Type	Default	Reset Event
7:0	DATA Data port used to access the registers listed in Table 16-8, "Register Summary" .	R/W	0h	RESET_VCC

16.10 EC Registers

Registers for this block are shown in the following summary table. Addresses for each register are determined by adding the offset shown in the "EC Offset" column to the Base Address for each instance of the [Mailbox Interface](#) Block in the Block Overview and Base Address Table in [Section 3.0, "Device Inventory"](#). In addition, the registers can be accessed through the Host Access Port, at the indexes listed in the following tables as "MBX_INDEX".

TABLE 16-8: REGISTER SUMMARY

EC Offset	Host I/O Index (MBX_INDEX)	Register Name
100h	00h	HOST-to-EC Mailbox Register
104h	01h	EC-to-Host Mailbox Register
108h	02h	SMI Interrupt Source Register
10Ch	03h	SMI Interrupt Mask Register
110h	10h	Mailbox register [0]
	11h	Mailbox register [1]
	12h	Mailbox register [2]
	13h	Mailbox register [3]

TABLE 16-8: REGISTER SUMMARY (CONTINUED)

EC Offset	Host I/O Index (MBX_INDEX)	Register Name
114h	14h	Mailbox register [4]
	15h	Mailbox register [5]
	16h	Mailbox register [6]
	17h	Mailbox register [7]
118h	18h	Mailbox register [8]
	19h	Mailbox register [9]
	1Ah	Mailbox register [A]
	1Bh	Mailbox register [B]
11Ch	1Ch	Mailbox register [C]
	1Dh	Mailbox register [D]
	1Eh	Mailbox register [E]
	1Fh	Mailbox register [F]
120h	20h	Mailbox register [10]
	21h	Mailbox register [11]
	22h	Mailbox register [12]
	23h	Mailbox register [13]
124h	24h	Mailbox register [14]
	25h	Mailbox register [15]
	26h	Mailbox register [16]
	27h	Mailbox register [17]
128h	28h	Mailbox register [18]
	29h	Mailbox register [19]
	2Ah	Mailbox register [1A]
	2Bh	Mailbox register [1B]
12Ch	2Ch	Mailbox register [1C]
	2Dh	Mailbox register [1D]
	2Eh	Mailbox register [1E]
	2Fh	Mailbox register [1F]

MEC1725

16.10.1 HOST-TO-EC MAILBOX REGISTER

Offset	100h			
MBX_INDEX	00h			
Bits	Description	Type	Default	Reset Event
7:0	<p>HOST_EC_MBOX</p> <p>If enabled, an interrupt to the EC marked by the MBX bit in the Interrupt Aggregator will be generated whenever the Host writes this register. The interrupt is cleared when this register is read by the EC.</p> <p>This register is cleared when written with FFh.</p> <p>This field is Read/Write when accessed through the Host Access Port. When written at the EC offset, each bit in this field is cleared when written with a '1b'. Writes of '0b' have no effect.</p>	<p>Host Access Port: R/W</p> <p>EC: R/WC</p>	0h	RESET_SYS

16.10.2 EC-TO-HOST MAILBOX REGISTER

Offset	104h			
MBX_INDEX	01h			
Bits	Description	Type	Default	Reset Event
7:0	<p>EC_HOST_MBOX</p> <p>An EC write to this register will set bit EC_WR in the SMI Interrupt Source Register to '1b'. If enabled, this will generate a Host SMI or a Host SERIRQ. The SERIRQ is cleared when this register is read by the Host.</p> <p>This register is cleared when written with FFh.</p> <p>This field is Read/Write when accessed by the EC at the EC offset. When written through the Host Access Port, each bit in this field is cleared when written with a '1b'. Writes of '0b' have no effect.</p>	<p>Host Access Port: R/WC</p> <p>EC: R/W</p>	0h	RESET_SYS

16.10.3 SMI INTERRUPT SOURCE REGISTER

Offset	108h			
MBX_INDEX	02h			
Bits	Description	Type	Default	Reset Event
7:1	<p>EC_SWI</p> <p>EC Software Interrupt. An SERIRQ to the Host is generated when any bit in this register when this bit is set to '1b' and the corresponding bit in the SMI Interrupt Mask Register register is '1b'.</p> <p>This field is Read/Write when accessed by the EC at the EC offset. When written through the Host Access Port, each bit in this field is cleared when written with a '1b'. Writes of '0b' have no effect.</p>	<p>Host Access Port: R/WC</p> <p>EC: R/W</p>	0h	RESET_SYS

Offset	108h			
MBX_INDEX	02h			
Bits	Description	Type	Default	Reset Event
0	<p>EC_WR EC Mailbox Write. This bit is set automatically when the EC-to-Host Mailbox Register has been written. An SMI or SERIRQ to the Host is generated when n this bit is '1b' and the corresponding bit in the SMI Interrupt Mask Register register is '1b'.</p> <p>This bit is automatically cleared by a read of the EC-to-Host Mailbox Register through the Host Access Port.</p> <p>This bit is read-only when read through the Host Access Port. It is neither readable nor writable directly by the EC when accessed at the EC offset.</p>	Host Access Port: R EC: -	0h	RESET_SYS

16.10.4 SMI INTERRUPT MASK REGISTER

Offset	10Ch			
MBX_INDEX	03h			
Bits	Description	Type	Default	Reset Event
7:1	<p>EC_SWI_EN EC Software Interrupt Enable. If this bit is '1b', the bit EC_WR in the SMI Interrupt Source Register is enabled for the generation of SERIRQ or nSMI events.</p>	R/W	0h	RESET_SYS
0	<p>EC_WR_EN EC Mailbox Write. Interrupt Enable. Each bit in this field that is '1b' enables the generation of SERIRQ interrupts when the corresponding bit in the EC_SWI field in the SMI Interrupt Source Register is '1b'.</p>	R/W	0h	RESET_SYS

MEC1725

17.0 UART

17.1 Introduction

The 16550 UART (Universal Asynchronous Receiver/Transmitter) is a full-function Serial Port that supports the standard RS-232 Interface.

17.2 References

- EIA Standard RS-232-C specification

17.3 Interface

This block is designed to be accessed externally via the pin interface and internally via a registered host interface.

FIGURE 17-1: I/O DIAGRAM OF BLOCK

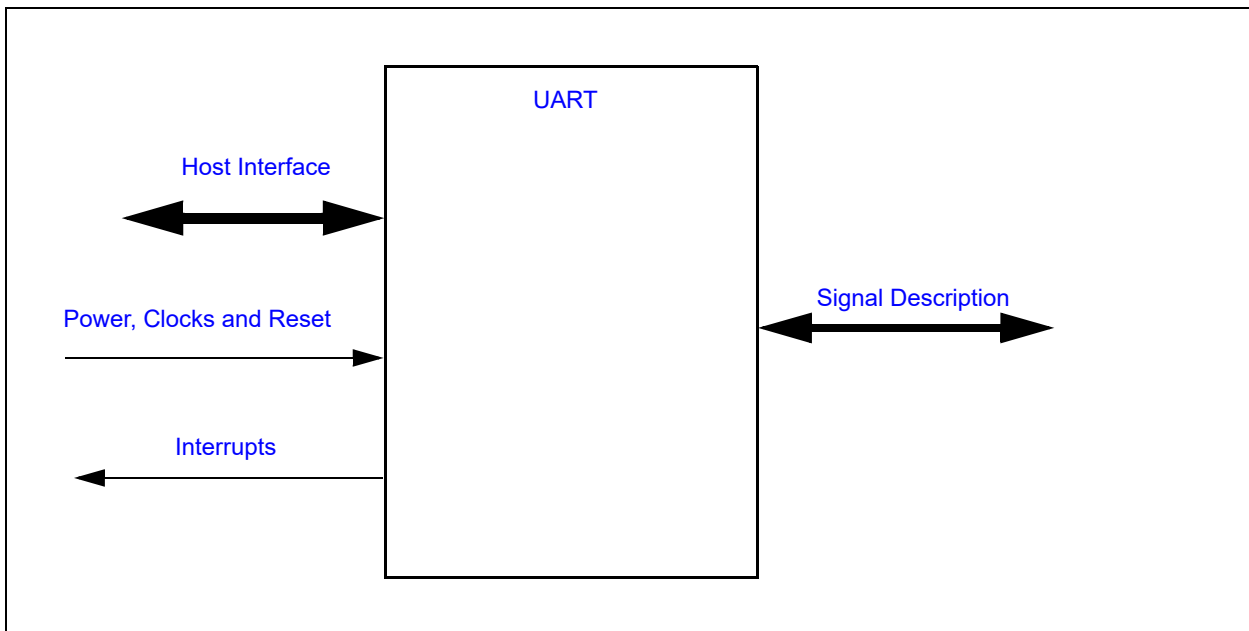

17.4 Signal Description

TABLE 17-1: SIGNAL DESCRIPTION TABLE

Name	Direction	Description
DTR#	Output	Active low Data Terminal ready output for the Serial Port. Handshake output signal notifies modem that the UART is ready to transmit data. This signal can be programmed by writing to bit 1 of the Modem Control Register (MCR). Note: Defaults to tri-state on V3_DUAL power on.
DCD#	Input	Active low Data Carrier Detect input for the serial port. Handshake signal which notifies the UART that carrier signal is detected by the modem. The CPU can monitor the status of DCD# signal by reading bit 7 of Modem Status Register (MSR). A DCD# signal state change from low to high after the last MSR read will set MSR bit 3 to a 1. If bit 3 of Interrupt Enable Register is set, the interrupt is generated when DCD # changes state.

TABLE 17-1: SIGNAL DESCRIPTION TABLE (CONTINUED)

Name	Direction	Description
DSR#	Input	Active low Data Set Ready input for the serial port. Handshake signal which notifies the UART that the modem is ready to establish the communication link. The CPU can monitor the status of DSR# signal by reading bit 5 of Modem Status Register (MSR). A DSR# signal state change from low to high after the last MSR read will set MSR bit 1 to a 1. If bit 3 of Interrupt Enable Register is set, the interrupt is generated when DSR# changes state.
RI#	Input	Active low Ring Indicator input for the serial port. Handshake signal which notifies the UART that the telephone ring signal is detected by the modem. The CPU can monitor the status of RI# signal by reading bit 6 of Modem Status Register (MSR). A RI# signal state change from low to high after the last MSR read will set MSR bit 2 to a 1. If bit 3 of Interrupt Enable Register is set, the interrupt is generated when RI# changes state.
RTS#	Output	Active low Request to Send output for the Serial Port. Handshake output signal notifies modem that the UART is ready to transmit data. This signal can be programmed by writing to bit 1 of the Modem Control Register (MCR). The hardware reset will reset the RTS# signal to inactive mode (high). RTS# is forced inactive during loop mode operation. Defaults to tri-state on V3_DUAL power on.
CTS#	Input	Active low Clear to Send input for the serial port. Handshake signal which notifies the UART that the modem is ready to receive data. The CPU can monitor the status of CTS# signal by reading bit 4 of Modem Status Register (MSR). A CTS# signal state change from low to high after the last MSR read will set MSR bit 0 to a 1. If bit 3 of the Interrupt Enable Register is set, the interrupt is generated when CTS# changes state. The CTS# signal has no effect on the transmitter.
TXD	Output	Transmit serial data output.
RXD	Input	Receiver serial data input.

17.5 Host Interface

The registers defined for UART is accessed by the various hosts as indicated in [Section 3.2, "Block Overview and Base Addresses"](#).

17.6 Power, Clocks and Reset

This section defines the Power, Clock, and Reset parameters of the block.

17.6.1 POWER DOMAINS

TABLE 17-2: POWER SOURCES

Name	Description
VTR_CORE	This Power Well is used to power the registers and logic in this block.

MEC1725

17.6.2 CLOCKS

TABLE 17-3: CLOCK INPUTS

Name	Description
UART_CLK	An external clock that may be used as an alternative to the internally-generated 1.8432MHz and 48MHz baud clocks. Selection between internal baud clocks and an external baud clock is configured by the CLK_SRC bit in the Configuration Select Register .
48MHz	This is the main clock domain. Because the clock input must be within $\pm 2\%$ in order to generate standard baud rates, the 48MHz clock must be generated by a reference clock with better than 1% accuracy and locked to its frequency before the UART will work with the standard rates.

TABLE 17-4: BAUD CLOCKS

Name	Description
1.8432MHz	The UART requires a 1.8432 MHz $\pm 2\%$ clock input for baud rate generation of standard baud rates up to 115,200 baud. It is derived from the system 48MHz clock domain.
48MHz	It may be used as an alternative to the 1.8432MHz clock, generating non-standard baud rates up to 1,500,000 baud.

17.6.3 RESETS

TABLE 17-5: RESET SIGNALS

Name	Description
RESET_SYS	This reset is asserted when VTR_CORE is applied.
RESET_HOST	This is an alternate reset condition, typically asserted when the main power rail is asserted.
RESET	This reset is determined by the POWER bit signal. When the power bit signal is 1, this signal is equal to RESET_VCC , if present. When the power bit signal is 0, this signal is equal to RESET_SYS .

17.7 Interrupts

This section defines the Interrupt Sources generated from this block.

TABLE 17-6: SYSTEM INTERRUPTS

Source	Description
UART	The UART interrupt event output indicates if an interrupt is pending. See Table 17-12, "Interrupt Control Table" .

TABLE 17-7: EC INTERRUPTS

Source	Description
UART	The UART interrupt event output indicates if an interrupt is pending. See Table 17-12, "Interrupt Control Table" .

17.8 Low Power Modes

The [UART](#) may be put into a low power state by the chip's Power, Clocks, and Reset (PCR) circuitry.

17.9 Description

The UART is compatible with the 16450, the 16450 ACE registers and the 16C550A. The UART performs serial-to-parallel conversions on received characters and parallel-to-serial conversions on transmit characters. Two sets of baud rates are provided. When the 1.8432 MHz source clock is selected, standard baud rates from 50 to 115.2K are available. When the source clock is 48MHz, baud rates up to 1,500K are available. The character options are programmable for 1 start; 1, 1.5 or 2 stop bits; even, odd, sticky or no parity; and prioritized interrupts. The UART contains a programmable baud rate generator that is capable of dividing the input clock signal by 1 to 32767. The UART is also capable of supporting the MIDI data rate. Refer to the Configuration Registers for information on disabling, powering down and changing the base address of the UART. The UART interrupt is enabled by programming OUT2 of the UART to logic "1." Because OUT2 is logic "0," it disables the UART's interrupt. The UART is accessible by both the Host and the EC.

17.9.1 PROGRAMMABLE BAUD RATE

The Serial Port contains a programmable Baud Rate Generator that is capable of dividing the internal clock source by any divisor from 1 to 32767. Unless an external clock source is configured, the clock source is either the 1.8432MHz clock source or the 48MHz clock source. The output frequency of the Baud Rate Generator is 16x the Baud rate. Two eight bit latches store the divisor in 16 bit binary format. These Divisor Latches must be loaded during initialization in order to ensure desired operation of the Baud Rate Generator. Upon loading either of the Divisor Latches, a 16 bit Baud counter is immediately loaded. This prevents long counts on initial load. If a 0 is loaded into the BRG registers, the output divides the clock by the number 3. If a 1 is loaded, the output is the inverse of the input oscillator. If a two is loaded, the output is a divide by 2 signal with a 50% duty cycle. If a 3 or greater is loaded, the output is low for 2 bits and high for the remainder of the count.

The following tables show possible baud rates.

TABLE 17-8: UART BAUD RATES USING CLOCK SOURCE 1.8432MHz

Desired Baud Rate	BAUD_CLOCK_SEL	Divisor Used to Generate 16X Clock
50	0	2304
75	0	1536
110	0	1047
134.5	0	857
150	0	768
300	0	384
600	0	192
1200	0	96
1800	0	64
2000	0	58
2400	0	48
3600	0	32
4800	0	24
7200	0	16
9600	0	12
19200	0	6
38400	0	3
57600	0	2
115200	0	1

TABLE 17-9: UART BAUD RATES USING CLOCK SOURCE 48MHz

Desired Baud Rate	BAUD_CLOCK_SEL	Divisor Used to Generate 16X Clock
125000	1	24
136400	1	22
150000	1	20
166700	1	18
187500	1	16
214300	1	14
250000	1	12
300000	1	10
375000	1	8
500000	1	6
750000	1	4
1500000	1	2
3000000	1	1

17.10 Runtime Registers

The registers listed in the Runtime Register Summary table are for a single instance of the [UART](#). Host access for each register listed in this table is defined as an offset in the Host address space to the Block's Base Address, as defined by the instance's Base Address Register.

The EC address for each register is formed by adding the Base Address for each instance of the [UART](#) shown in the Block Overview and Base Address Table in [Section 3.0, "Device Inventory"](#) to the offset shown in the "Offset" column.

TABLE 17-10: RUNTIME REGISTER SUMMARY

DLAB Note 1	Offset	Register Name
0	0h	Receive Buffer Register
0	0h	Transmit Buffer Register
1	0h	Programmable Baud Rate Generator LSB Register
1	1h	Programmable Baud Rate Generator MSB Register
0	1h	Interrupt Enable Register
x	02h	FIFO Control Register
x	02h	Interrupt Identification Register
x	03h	Line Control Register
x	04h	Modem Control Register
x	05h	Line Status Register
x	06h	Modem Status Register
x	07h	Scratchpad Register

Note 1: DLAB is bit 7 of the Line Control Register.

17.10.1 RECEIVE BUFFER REGISTER

Offset	0h (DLAB=0)			
Bits	Description	Type	Default	Reset Event
7:0	RECEIVED_DATA This register holds the received incoming data byte. Bit 0 is the least significant bit, which is transmitted and received first. Received data is double buffered; this uses an additional shift register to receive the serial data stream and convert it to a parallel 8 bit word which is transferred to the Receive Buffer register. The shift register is not accessible.	R	0h	RESET

17.10.2 TRANSMIT BUFFER REGISTER

Offset	0h (DLAB=0)			
Bits	Description	Type	Default	Reset Event
7:0	TRANSMIT_DATA This register contains the data byte to be transmitted. The transmit buffer is double buffered, utilizing an additional shift register (not accessible) to convert the 8 bit data word to a serial format. This shift register is loaded from the Transmit Buffer when the transmission of the previous byte is complete.	W	0h	RESET

17.10.3 PROGRAMMABLE BAUD RATE GENERATOR LSB REGISTER

Offset	00h (DLAB=1)			
Bits	Description	Type	Default	Reset Event
7:0	BAUD_RATE_DIVISOR_LSB See Section 17.9.1, "Programmable Baud Rate" .	R/W	0h	RESET

MEC1725

17.10.4 PROGRAMMABLE BAUD RATE GENERATOR MSB REGISTER

Offset	01h (DLAB=1)			
Bits	Description	Type	Default	Reset Event
7	BAUD_CLK_SEL If CLK_SRC is '0': <ul style="list-style-type: none">• 0=The baud clock is derived from the 1.8432MHz.• 1=The baud clock is derived from the 48MHz. If CLK_SRC is '1': <ul style="list-style-type: none">• This bit has no effect	R/W	0h	RESET
6:0	BAUD_RATE_DIVISOR_MSB See Section 17.9.1, "Programmable Baud Rate" .	R/W	0h	RESET

17.10.5 INTERRUPT ENABLE REGISTER

The lower four bits of this register control the enables of the five interrupt sources of the Serial Port interrupt. It is possible to totally disable the interrupt system by resetting bits 0 through 3 of this register. Similarly, setting the appropriate bits of this register to a high, selected interrupts can be enabled. Disabling the interrupt system inhibits the Interrupt Identification Register and disables any Serial Port interrupt out of the MEC1725. All other system functions operate in their normal manner, including the Line Status and MODEM Status Registers. The contents of the Interrupt Enable Register are described below.

Offset	01h (DLAB=0)			
Bits	Description	Type	Default	Reset Event
7:4	Reserved	RES	-	-
3	EMSI This bit enables the MODEM Status Interrupt when set to logic "1". This is caused when one of the Modem Status Register bits changes state.	R/W	0h	RESET
2	ELSI This bit enables the Received Line Status Interrupt when set to logic "1". The error sources causing the interrupt are Overrun, Parity, Framing and Break. The Line Status Register must be read to determine the source.	R/W	0h	RESET
1	ETHREI This bit enables the Transmitter Holding Register Empty Interrupt when set to logic "1".	R/W	0h	RESET
0	ERDAI This bit enables the Received Data Available Interrupt (and timeout interrupts in the FIFO mode) when set to logic "1".	R/W	0h	RESET

17.10.6 FIFO CONTROL REGISTER

This is a write only register at the same location as the [Interrupt Identification Register](#).

Note: DMA is not supported.

Offset	02h			
Bits	Description	Type	Default	Reset Event
7:6	RCV_FIFO_TRIGGER_LEVEL These bits are used to set the trigger level for the RCVR FIFO interrupt.	W	0h	RESET
5:4	Reserved	RES	-	-
3	DMA_MODE_SELECT Writing to this bit has no effect on the operation of the UART. The RXRDY and TXRDY pins are not available on this chip.	W	0h	RESET
2	CLEAR_XMIT_FIFO Setting this bit to a logic "1" clears all bytes in the XMIT FIFO and resets its counter logic to "0". The shift register is not cleared. This bit is self-clearing.	W	0h	RESET
1	CLEAR_RECV_FIFO Setting this bit to a logic "1" clears all bytes in the RCVR FIFO and resets its counter logic to "0". The shift register is not cleared. This bit is self-clearing.	W	0h	RESET
0	EXRF Enable XMIT and RECV FIFO. Setting this bit to a logic "1" enables both the XMIT and RCVR FIFOs. Clearing this bit to a logic "0" disables both the XMIT and RCVR FIFOs and clears all bytes from both FIFOs. When changing from FIFO Mode to non-FIFO (16450) mode, data is automatically cleared from the FIFOs. This bit must be a 1 when other bits in this register are written to or they will not be properly programmed.	W	0h	RESET

TABLE 17-11: RECV FIFO TRIGGER LEVELS

Bit 7	Bit 6	RCV FIFO Trigger Level (BYTES)
0	0	1
	1	4
1	0	8
	1	14

17.10.7 INTERRUPT IDENTIFICATION REGISTER

By accessing this register, the host CPU can determine the highest priority interrupt and its source. Four levels of priority interrupt exist. They are in descending order of priority:

1. Receiver Line Status (highest priority)
2. Received Data Ready

MEC1725

3. Transmitter Holding Register Empty
4. MODEM Status (lowest priority)

Information indicating that a prioritized interrupt is pending and the source of that interrupt is stored in the Interrupt Identification Register (refer to [Table 17-12](#)). When the CPU accesses the IIR, the Serial Port freezes all interrupts and indicates the highest priority pending interrupt to the CPU. During this CPU access, even if the Serial Port records new interrupts, the current indication does not change until access is completed. The contents of the IIR are described below.

Offset	02h			
Bits	Description	Type	Default	Reset Event
7:6	FIFO_EN These two bits are set when the FIFO CONTROL Register bit 0 equals 1.	R	0h	RESET
5:4	Reserved	RES	-	-
3:1	INTID These bits identify the highest priority interrupt pending as indicated by Table 17-12, "Interrupt Control Table" . In non-FIFO mode, Bit[3] is a logic "0". In FIFO mode Bit[3] is set along with Bit[2] when a timeout interrupt is pending.	R	0h	RESET
0	IPEND This bit can be used in either a hardwired prioritized or polled environment to indicate whether an interrupt is pending. When bit 0 is a logic '0' an interrupt is pending and the contents of the IIR may be used as a pointer to the appropriate internal service routine. When bit 0 is a logic '1' no interrupt is pending.	R	1h	RESET

TABLE 17-12: INTERRUPT CONTROL TABLE

FIFO Mode Only	Interrupt Identification Register			Interrupt SET and RESET Functions				
	Bit 3	Bit 2	Bit 1	Bit 0	Priority Level	Interrupt Type	Interrupt Source	Interrupt Reset Control
0	0	0	0	1	-	None	None	-
	1	1	1	0	Highest	Receiver Line Status	Overrun Error, Parity Error, Framing Error or Break Interrupt	Reading the Line Status Register
0			Second	Received Data Available	Receiver Data Available	Read Receiver Buffer or the FIFO drops below the trigger level.		
1	0	1		0	Third	Character Timeout Indication	No Characters Have Been Removed From or Input to the RCVR FIFO during the last 4 Char times and there is at least 1 char in it during this time	Reading the Receiver Buffer Register
0			0			1	Transmitter Holding Register Empty	Transmitter Holding Register Empty
0	0	0	0	Fourth	MODEM Status	Clear to Send or Data Set Ready or Ring Indicator or Data Carrier Detect	Reading the MODEM Status Register	

MEC1725

17.10.8 LINE CONTROL REGISTER

Offset	03h			
Bits	Description	Type	Default	Reset Event
7	DLAB Divisor Latch Access Bit (DLAB). It must be set high (logic "1") to access the Divisor Latches of the Baud Rate Generator during read or write operations. It must be set low (logic "0") to access the Receiver Buffer Register, the Transmitter Holding Register, or the Interrupt Enable Register.	R/W	0h	RESET
6	BREAK_CONTROL Set Break Control bit. When bit 6 is a logic "1", the transmit data output (TXD) is forced to the Spacing or logic "0" state and remains there (until reset by a low level bit 6) regardless of other transmitter activity. This feature enables the Serial Port to alert a terminal in a communications system.	R/W	0h	RESET
5	STICK_PARITY Stick Parity bit. When parity is enabled it is used in conjunction with bit 4 to select Mark or Space Parity. When LCR bits 3, 4 and 5 are 1 the Parity bit is transmitted and checked as a 0 (Space Parity). If bits 3 and 5 are 1 and bit 4 is a 0, then the Parity bit is transmitted and checked as 1 (Mark Parity). If bit 5 is 0 Stick Parity is disabled. Bit 3 is a logic "1" and bit 5 is a logic "1", the parity bit is transmitted and then detected by the receiver in the opposite state indicated by bit 4.	R/W	0h	RESET
4	PARITY_SELECT Even Parity Select bit. When bit 3 is a logic "1" and bit 4 is a logic "0", an odd number of logic "1"s is transmitted or checked in the data word bits and the parity bit. When bit 3 is a logic "1" and bit 4 is a logic "1" an even number of logic "1"s is transmitted and checked.	R/W	0h	RESET
3	ENABLE_PARITY Parity Enable bit. When bit 3 is a logic "1", a parity bit is generated (transmit data) or checked (receive data) between the last data word bit and the first stop bit of the serial data. (The parity bit is used to generate an even or odd number of 1s when the data word bits and the parity bit are summed).	R/W	0h	RESET
2	STOP_BITS This bit specifies the number of stop bits in each transmitted or received serial character. Table 17-13 summarizes the information. The receiver will ignore all stop bits beyond the first, regardless of the number used in transmitting.	R/W	0h	RESET
1:0	WORD_LENGTH These two bits specify the number of bits in each transmitted or received serial character. The encoding of bits 0 and 1 is as follows:	R/W	0h	RESET

TABLE 17-13: STOP BITS

Bit 2	Word Length	Number of Stop Bits
0	--	1
1	5 bits	1.5
	6 bits	
	7 bits	
	8 bits	

TABLE 17-14: SERIAL CHARACTER

Bit 1	Bit 0	Word Length
0	0	5 Bits
0	1	6 Bits
1	0	7 Bits
1	1	8 Bits

The Start, Stop and Parity bits are not included in the word length.

MEC1725

17.10.9 MODEM CONTROL REGISTER

Offset	04h			
Bits	Description	Type	Default	Reset Event
7:5	Reserved	RES	-	-
4	LOOPBACK This bit provides the loopback feature for diagnostic testing of the Serial Port. When bit 4 is set to logic "1", the following occur: <ol style="list-style-type: none">1. The TXD is set to the Marking State (logic "1").2. The receiver Serial Input (RXD) is disconnected.3. The output of the Transmitter Shift Register is "looped back" into the Receiver Shift Register input.4. All MODEM Control inputs (CTS#, DSR#, RI# and DCD#) are disconnected.5. The four MODEM Control outputs (DTR#, RTS#, OUT1 and OUT2) are internally connected to the four MODEM Control inputs (DSR#, CTS#, RI#, DCD#).6. The Modem Control output pins are forced inactive high.7. Data that is transmitted is immediately received. This feature allows the processor to verify the transmit and receive data paths of the Serial Port. In the diagnostic mode, the receiver and the transmitter interrupts are fully operational. The MODEM Control Interrupts are also operational but the interrupts' sources are now the lower four bits of the MODEM Control Register instead of the MODEM Control inputs. The interrupts are still controlled by the Interrupt Enable Register.	R/W	0h	RESET
3	OUT2 Output 2 (OUT2). This bit is used to enable an UART interrupt. When OUT2 is a logic "0", the serial port interrupt output is forced to a high impedance state - disabled. When OUT2 is a logic "1", the serial port interrupt outputs are enabled.	R/W	0h	RESET
2	OUT1 This bit controls the Output 1 (OUT1) bit. This bit does not have an output pin and can only be read or written by the CPU.	R/W	0h	RESET
1	RTS This bit controls the Request To Send (RTS#) output. When bit 1 is set to a logic "1", the RTS# output is forced to a logic "0". When bit 1 is set to a logic "0", the RTS# output is forced to a logic "1".	R/W	0h	RESET
0	DTR This bit controls the Data Terminal Ready (DTR#) output. When bit 0 is set to a logic "1", the DTR# output is forced to a logic "0". When bit 0 is a logic "0", the DTR# output is forced to a logic "1".	R/W	0h	RESET

17.10.10 LINE STATUS REGISTER

Offset	05h			
Bits	Description	Type	Default	Reset Event
7	FIFO_ERROR This bit is permanently set to logic "0" in the 450 mode. In the FIFO mode, this bit is set to a logic "1" when there is at least one parity error, framing error or break indication in the FIFO. This bit is cleared when the LSR is read if there are no subsequent errors in the FIFO.	R	0h	RESET
6	TRANSMIT_ERROR Transmitter Empty. Bit 6 is set to a logic "1" whenever the Transmitter Holding Register (THR) and Transmitter Shift Register (TSR) are both empty. It is reset to logic "0" whenever either the THR or TSR contains a data character. Bit 6 is a read only bit. In the FIFO mode this bit is set whenever the THR and TSR are both empty,	R	0h	RESET
5	TRANSMIT_EMPTY Transmitter Holding Register Empty Bit 5 indicates that the Serial Port is ready to accept a new character for transmission. In addition, this bit causes the Serial Port to issue an interrupt when the Transmitter Holding Register interrupt enable is set high. The THRE bit is set to a logic "1" when a character is transferred from the Transmitter Holding Register into the Transmitter Shift Register. The bit is reset to logic "0" whenever the CPU loads the Transmitter Holding Register. In the FIFO mode this bit is set when the XMIT FIFO is empty, it is cleared when at least 1 byte is written to the XMIT FIFO. Bit 5 is a read only bit.	R	0h	RESET
4	BREAK_INTERRUPT Break Interrupt. Bit 4 is set to a logic "1" whenever the received data input is held in the Spacing state (logic "0") for longer than a full word transmission time (that is, the total time of the start bit + data bits + parity bits + stop bits). The BI is reset after the CPU reads the contents of the Line Status Register. In the FIFO mode this error is associated with the particular character in the FIFO it applies to. This error is indicated when the associated character is at the top of the FIFO. When break occurs only one zero character is loaded into the FIFO. Restarting after a break is received, requires the serial data (RXD) to be logic "1" for at least 1/2 bit time. Bits 1 through 4 are the error conditions that produce a Receiver Line Status Interrupt BIT 3 whenever any of the corresponding conditions are detected and the interrupt is enabled	R	0h	RESET

MEC1725

Offset	05h			
Bits	Description	Type	Default	Reset Event
3	FRAME_ERROR Framing Error. Bit 3 indicates that the received character did not have a valid stop bit. Bit 3 is set to a logic "1" whenever the stop bit following the last data bit or parity bit is detected as a zero bit (Spacing level). This bit is reset to a logic "0" whenever the Line Status Register is read. In the FIFO mode this error is associated with the particular character in the FIFO it applies to. This error is indicated when the associated character is at the top of the FIFO. The Serial Port will try to resynchronize after a framing error. To do this, it assumes that the framing error was due to the next start bit, so it samples this 'start' bit twice and then takes in the 'data'.	R	0h	RESET
2	PARITY ERROR Parity Error. Bit 2 indicates that the received data character does not have the correct even or odd parity, as selected by the even parity select bit. This bit is set to a logic "1" upon detection of a parity error and is reset to a logic "0" whenever the Line Status Register is read. In the FIFO mode this error is associated with the particular character in the FIFO it applies to. This error is indicated when the associated character is at the top of the FIFO.	R	0h	RESET
1	OVERRUN_ERROR Overrun Error. Bit 1 indicates that data in the Receiver Buffer Register was not read before the next character was transferred into the register, thereby destroying the previous character. In FIFO mode, an overrun error will occur only when the FIFO is full and the next character has been completely received in the shift register, the character in the shift register is overwritten but not transferred to the FIFO. This bit is set to a logic "1" immediately upon detection of an overrun condition, and reset whenever the Line Status Register is read.	R	0h	RESET
0	DATA_READY Data Ready. It is set to a logic '1' whenever a complete incoming character has been received and transferred into the Receiver Buffer Register or the FIFO. Bit 0 is reset to a logic '0' by reading all of the data in the Receive Buffer Register or the FIFO.	R	0h	RESET

17.10.11 MODEM STATUS REGISTER

Offset	06h			
Bits	Description	Type	Default	Reset Event
7	DCD This bit is the complement of the Data Carrier Detect (DCD#) input. If bit 4 of the MCR is set to logic '1', this bit is equivalent to OUT2 in the MCR.	R	0h	RESET
6	RI This bit is the complement of the Ring Indicator (RI#) input. If bit 4 of the MCR is set to logic '1', this bit is equivalent to OUT1 in the MCR.	R	0h	RESET
5	DSR This bit is the complement of the Data Set Ready (DSR#) input. If bit 4 of the MCR is set to logic '1', this bit is equivalent to DTR# in the MCR.	R	0h	RESET
4	CTS This bit is the complement of the Clear To Send (CTS#) input. If bit 4 of the MCR is set to logic '1', this bit is equivalent to RTS# in the MCR.	R	0h	RESET
3	DDCD Delta Data Carrier Detect (DDCD). Bit 3 indicates that the DCD# input to the chip has changed state. NOTE: Whenever bit 0, 1, 2, or 3 is set to a logic '1', a MODEM Status Interrupt is generated.	R	0h	RESET
2	TERI Trailing Edge of Ring Indicator (TERI). Bit 2 indicates that the RI# input has changed from logic '0' to logic '1'.	R	0h	RESET
1	DDSR Delta Data Set Ready (DDSR). Bit 1 indicates that the DSR# input has changed state since the last time the MSR was read.	R	0h	RESET
0	DCTS Delta Clear To Send (DCTS). Bit 0 indicates that the CTS# input to the chip has changed state since the last time the MSR was read.	R	0h	RESET

MEC1725

17.10.12 SCRATCHPAD REGISTER

Offset	07h			
Bits	Description	Type	Default	Reset Event
7:0	SCRATCH This 8 bit read/write register has no effect on the operation of the Serial Port. It is intended as a scratchpad register to be used by the programmer to hold data temporarily.	R/W	0h	RESET

17.11 Configuration Registers

Configuration Registers for an instance of the [UART](#) are listed in the following table. Host access to Configuration Registers is through the Configuration Port using the Logical Device Number of each instance of the [UART](#) and the Index shown in the "Host Index" column of the table. The EC can access Configuration Registers directly. The EC address for each register is formed by adding the Base Address for each instance of the [UART](#) shown in the Block Overview and Base Address Table in [Section 3.0, "Device Inventory"](#) to the offset shown in the "EC Offset" column.

TABLE 17-15: CONFIGURATION REGISTER SUMMARY

EC Offset	Host Index	Register Name
330h	30h	Activate Register
3F0h	F0h	Configuration Select Register

17.11.1 ACTIVATE REGISTER

Offset	30h			
Bits	Description	Type	Default	Reset Event
7:1	Reserved	RES	-	-
0	ACTIVATE When this bit is 1, the UART logical device is powered and functional. When this bit is 0, the UART logical device is powered down and inactive.	R/W	0b	RESET

17.11.2 CONFIGURATION SELECT REGISTER

Offset	F0h			
Bits	Description	Type	Default	Reset Event
7:3	Reserved	RES	-	-
2	POLARITY 1=The UART_TX and UART_RX pins functions are inverted 0=The UART_TX and UART_RX pins functions are not inverted	R/W	0b	RESET
1	POWER 1=The RESET reset signal is derived from RESET_HOST 0=The RESET reset signal is derived from RESET_SYS	R/W	1b	RESET
0	CLK_SRC 1=The UART Baud Clock is derived from an external clock source 0=The UART Baud Clock is derived from one of the two internal clock sources	R/W	0b	RESET

MEC1725

18.0 GPIO INTERFACE

18.1 General Description

The MEC1725 [GPIO Interface](#) provides general purpose input monitoring and output control, as well as managing many aspects of pin functionality; including, multi-function Pin Multiplexing Control, [GPIO Direction](#) control, [PU/PD \(PU_PD\)](#) resistors, asynchronous wakeup and synchronous [Interrupt Detection \(int_det\)](#), [GPIO Direction](#), and [Polarity](#) control, as well as control of pin drive strength and slew rate.

Features of the [GPIO Interface](#) include:

- Inputs:
 - Asynchronous rising and falling edge wakeup detection
 - Interrupt High or Low Level
- On Output:
 - Push Pull or Open Drain output
- Pull up or pull down resistor control
- Interrupt and wake capability available for all GPIOs
- Programmable pin drive strength and slew rate limiting
- Group- or individual control of GPIO data.
- Multiplexing of all multi-function pins are controlled by the GPIO interface

18.2 Block Diagram

The [GPIO Interface Block Diagram](#) shown in [Figure 18-1](#) illustrates the functionality of a single MEC1725 [GPIO Interface](#) pin. The source for the Pin Multiplexing Control, [Interrupt Detection \(int_det\)](#), [GPIO Direction](#), and [Polarity](#) controls in [Figure 18-1](#) is a [Pin Control Register](#) that is associated with each pin (see [Section 18.7.1.1, "Pin Control Register,"](#) on page 303).

FIGURE 18-1: GPIO INTERFACE BLOCK DIAGRAM

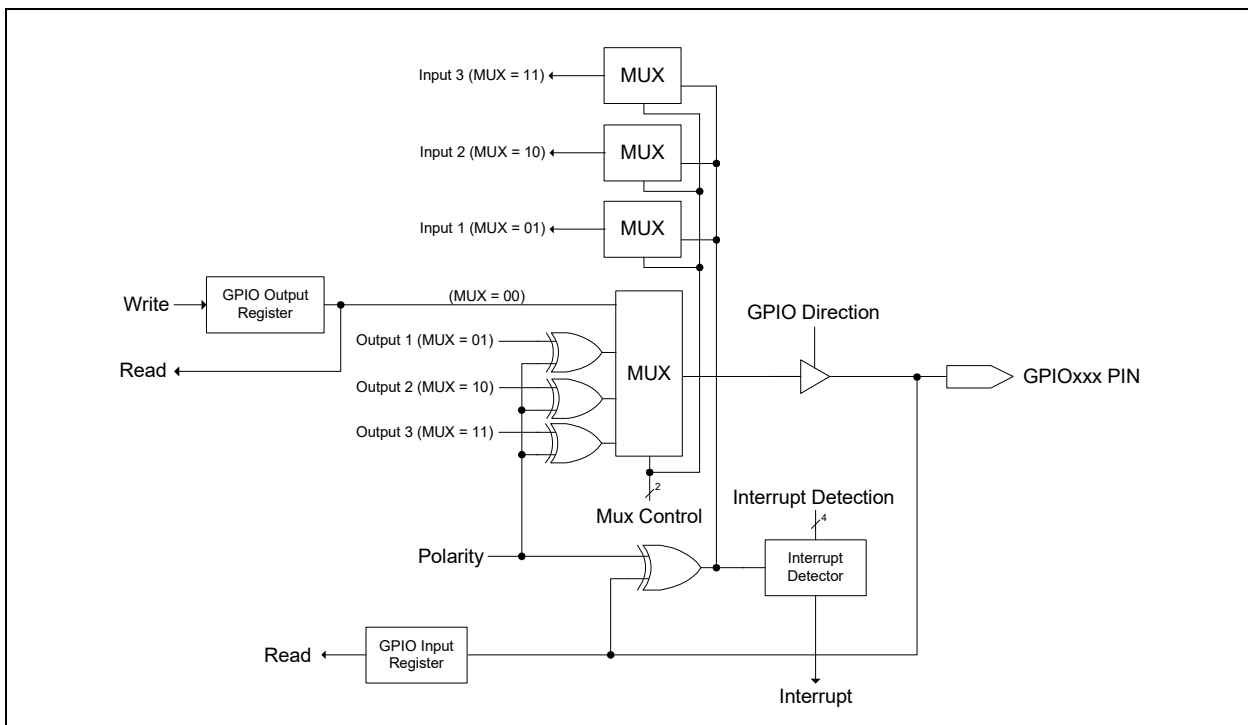

18.3 Power, Clocks and Reset

This section defines the Power, Clock, and Reset parameters of the block.

18.3.1 POWER DOMAINS

Name	Description
VTR_CORE	The registers and logic in this block are powered by VTR_CORE.

18.3.2 CLOCK INPUTS

Name	Description
48MHz	The 48MHz is used for synchronizing the GPIO inputs.

18.3.3 RESETS

Name	Description
RESET_SYS	This reset is asserted when VTR_CORE is applied.
RESET_VCC	This is an alternate reset condition, typically asserted when the main power rail is asserted. This reset is used for VCC Power Well Emulation.

18.4 Interrupts

This section defines the Interrupt Sources generated from this block.

Source	Description
GPIO_Event	<p>Each pin in the GPIO Interface has the ability to generate an interrupt event. This event may be used as a wake event.</p> <p>The GPIO Interface can generate an interrupt source event on a high level, low level, rising edge and falling edge, as configured by the Interrupt Detection (int_det) bits in the Pin Control Register associated with the GPIO signal function.</p> <p>Note: The minimum pulse width required to generate an interrupt/wakeup event is 5ns.</p>

18.5 Description

The GPIO Interface refers to all the GPIOxxx pins implemented in the design. GPIO stands for General Purpose I/O.

The GPIO signals may be used by firmware to both monitor and control a pin in “bit-banged” mode. The GPIOs may be individually controlled via their [Pin Control Register](#) or group controlled via the Output and Input GPIO registers. The [GPIO Output Control Select](#)

The GPIO Pin control registers are used to select the alternate functions on GPIO pins (unless otherwise specified), to control the buffer direction, strength, and polarity, to control the internal pull-ups and pull-downs, for VCC emulation, and for selecting the event type that causes a GPIO interrupt.

The GPIO input is always live, even when an alternate function is selected. Firmware may read the GPIO input anytime to see the value on the pin. In addition, the GPIO interrupt is always functional, and may be used for either the GPIO itself or to support the alternate functions on the pin. See [FIGURE 18-1: GPIO Interface Block Diagram on page 298](#).

18.6 GPIO Pass-Through Ports

GPIO Pass-Through Ports (GPTP) can multiplex two general purpose I/O pins as shown in [Figure 18-2](#). GPIO Pass-Through Ports connect the GPTP-IN pin to the GPTP-OUT pin. The GPTP are sequentially assigned values 0:7. The GPTP port assignment have no relation to the GPIO Indexing assignments. The GPTP ports are controlled by the Mux Control bits in the Pin Control Register associated with the GPTP-OUT signal function.

In order to enable the GPTP Pass-Through Mode, the GPTP-IN (GPIOm in [Figure 18-2](#)) Pin Control Register must assign the Mux Control to the GPTP_IN signal function and the GPIO Direction bit to 0 (input); the GPTP-OUT (GPIOn in [Figure 18-2](#)) Pin Control Register must assign the Mux Control to the GPTP_OUT signal function and the GPIO Direction bit to 1 (output). The GPTP-OUT signal function can differ from pin to pin.

FIGURE 18-2: GPIO PASS-THROUGH PORT EXAMPLE

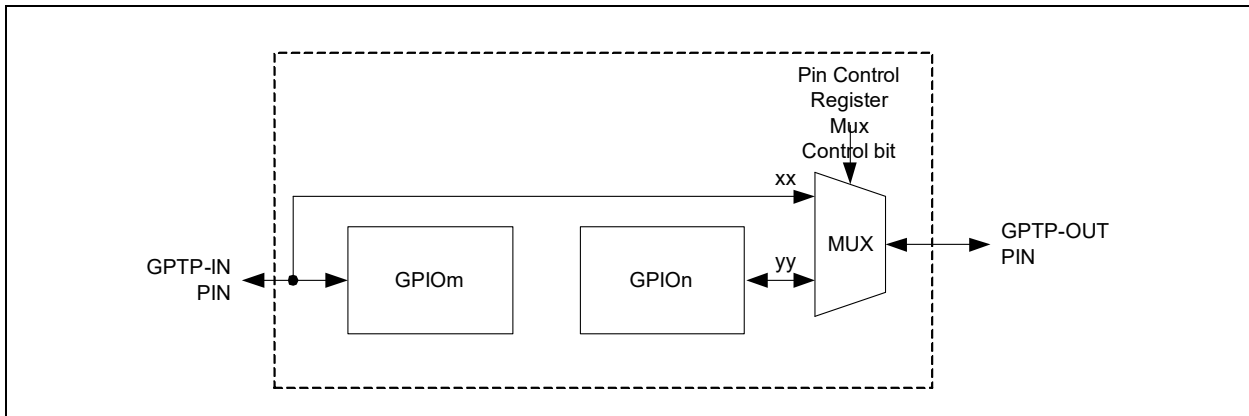

The Pin Control Register Mux Control fields shown in [Figure 18-2](#) are illustrated as 'xx' and 'yy' because this figure is an example, it does not represent the actual GPIO multiplexing configuration. The GPIO Multiplexing tables in this chapter must be used to determine the correct values to use to select between a GPIO and the pass-through.

When Pass-Through Mode is enabled, the GPIOn output is disconnected from the GPIOn pin and the GPIOm pin signal appears on GPIOn pin. Note that in this case the GPIOm input register still reflects the state of the GPIOm pin.

18.6.1 ACCESSING GPIOs

There are two ways to access GPIO output data. Bit [10] is used to determine which GPIO output data bit affects the GPIO output pin.

- Grouped Output GPIO Data
 - Outputs to individual GPIO ports are grouped into 32-bit [GPIO Output Registers](#).
- Individual [GPIO output data](#)
 - Alternatively, each GPIO output port is individually accessible via Bit [16] in the port's [Pin Control Register](#). On reads, Bit [16] returns the programmed value, not the value on the pin.

There are two ways to access GPIO input data.

- Input GPIO Data
 - Inputs from individual GPIO ports are grouped into 32-bit [GPIO Input Registers](#) and always reflect the current state of the GPIO input from the pad.
- [GPIO input from pad](#)
 - Alternatively, each GPIO input port is individually accessible via Bit [24] in the port's [Pin Control Register](#). Bit [24] always reflects the current state of GPIO input from the pad.

18.6.2 GPIO INDEXING

Each GPIO signal function name consists of a 4-character prefix ("GPIO") followed by a 3-digit octal-encoded index number. In the MEC1725 GPIO indexing is done sequentially starting from 'GPIO000.'

18.6.3 PIN CONTROL REGISTERS

Each GPIO has two Pin Control registers. The [Pin Control Register](#), which is the primary register, is used to read the value of the input data and set the output either high or low. It is used to select the alternate function via the [Mux Control](#) bits, set the [Polarity](#) of the input, configure and enable the output buffer, configure the GPIO interrupt event source, enable internal pull-up/pull-down resistors, and to enable VCC Emulation via the [Power Gating Signals \(PGS\)](#) control bits. The [Pin Control Register 2](#) is used to configure the output buffer drive strength and slew rate.

The following tables define the default settings for the two Pin Control registers for each GPIO in each product group.

18.6.3.1 Pin Control Register Defaults

Please refer to [Section 3.5, "GPIO Register Assignments"](#) for the Pin Control Register default information.

18.7 GPIO Registers

The registers listed in the Register Summary table are for a single instance of the MEC1725. The addresses of each register listed in this table are defined as a relative offset to the host "Base Address" defined in the Register Base Address Table.

TABLE 18-1: REGISTER BASE ADDRESS TABLE

Instance Name	Instance Number	Host	Address Space	Base Address
GPIO	0	eSPI	I/O	Note 18-2
	0	EC	32-bit internal address space	4008_1000h Note 18-1

Note 18-1 The Base Address indicates where the first register can be accessed in a particular address space for a block instance.

Note 18-2 The GPIO registers may be accessed by the eSPI Host via the EMI block via GPIO commands or by direct access if enabled by firmware. See the firmware documentation for a description of this access method.

Note: Registers and bits associated with GPIOs not implemented are Reserved. Please refer to [Section 2.3, "Pin List"](#) for GPIOs implemented in the chip.

TABLE 18-2: REGISTER SUMMARY

Offset	Register Name
000h - 01Ch	GPIO000-GPIO007 Pin Control Register
020h - 03Ch	GPIO010-GPIO017 Pin Control Register
040h - 05Ch	GPIO020-GPIO027 Pin Control Register
060h - 078h	GPIO030-GPIO036 Pin Control Register
080h - 09Ch	GPIO040-GPIO047 Pin Control Register
0A0h - 0BCh	GPIO050-GPIO057 Pin Control Register
0C0h - 0DCh	GPIO060-GPIO067 Pin Control Register
0E0h - 0F8h	GPIO070-GPIO077 Pin Control Register

MEC1725

TABLE 18-2: REGISTER SUMMARY (CONTINUED)

Offset	Register Name
100h - 11Ch	GPIO100-GPIO107 Pin Control Register
128h - 13Ch	GPIO112-GPIO117 Pin Control Register
140h - 15Ch	GPIO120-GPIO127 Pin Control Register
160h - 16Ch	GPIO130-GPIO137 Pin Control Register
180h - 19Ch	GPIO140-GPIO147 Pin Control Register
1A0h - 1BCh	GPIO150-GPIO157 Pin Control Register
1C0h - 1DCh	GPIO160-GPIO167 Pin Control Register
1E0h - 1F4h	GPIO170-GPIO177 Pin Control Register
200h - 21Ch	GPIO200-GPIO207 Pin Control Register
220h - 23Ch	GPIO210-GPIO217 Pin Control Register
240h - 25Ch	GPIO221-GPIO227 Pin Control Register
260h - 27Ch	Reserved
280h - 298h	GPIO240-GPIO247 Pin Control Register
2ACh - 2BCh	GPIO253-GPIO257 Pin Control Register
2C0h	GPIO260 Pin Control Register
300h	Input GPIO[000:036]
304h	Input GPIO[040:076]
308h	Input GPIO[100:127]
30Ch	Input GPIO[140:176]
310h	Input GPIO[200:236]
314h	Input GPIO[240:276]
380h	Output GPIO[000:036]
384h	Output GPIO[040:076]
388h	Output GPIO[100:127]
38Ch	Output GPIO[140:176]
390h	Output GPIO[200:236]
394h	Output GPIO[240:276]
500h - 51Ch	GPIO000-GPIO007 Pin Control Register 2
520h - 53Ch	GPIO010-GPIO017 Pin Control Register 2
540h - 55Ch	GPIO020-GPIO027 Pin Control Register 2
560h - 578h	GPIO030-GPIO036 Pin Control Register 2
580h - 59Ch	GPIO040-GPIO047 Pin Control Register 2

TABLE 18-2: REGISTER SUMMARY (CONTINUED)

Offset	Register Name
5A0h - 5BCh	GPIO050-GPIO057 Pin Control Register 2
5C0h - 5DCh	GPIO060-GPIO067 Pin Control Register 2
5E0h - 5F8h	GPIO070-GPIO076 Pin Control Register 2
600h - 61Ch	GPIO100-GPIO107 Pin Control Register 2
620h - 63Ch	GPIO110-GPIO117 Pin Control Register 2
640h - 65Ch	GPIO120-GPIO127 Pin Control Register 2
660h - 674h	GPIO130-GPIO135 Pin Control Register 2
680h - 69Ch	GPIO140-GPIO147 Pin Control Register 2
6A0h - 6BCh	GPIO150-GPIO157 Pin Control Register 2
6C0h - 6D8h	GPIO160-GPIO167 Pin Control Register 2
6E0h - 6F4h	GPIO170-GPIO175 Pin Control Register 2
700h - 71Ch	GPIO200-GPIO207 Pin Control Register 2
720h - 73Ch	GPIO210-GPIO217 Pin Control Register 2
740h - 75Ch	GPIO220-GPIO227 Pin Control Register 2
760h - 778h	Reserved
780h - 79Ch	GPIO240-GPIO247 Pin Control Register 2
7A0h - 7BCh	GPIO250-GPIO257 Pin Control Register 2
7C0h	GPIO260 Pin Control Register 2

18.7.1 PIN CONTROL REGISTERS

Two [Pin Control Registers](#) are implemented for each GPIO. The [Pin Control Register](#) format is described in [Section 18.7.1.1, "Pin Control Register,"](#) on page 303. The [Pin Control Register 2](#) format is described in [Section 18.7.1.2, "Pin Control Register 2,"](#) on page 308. [Pin Control Register](#) address offsets and defaults for each product are defined in [Section 18.6.3.1, "Pin Control Register Defaults,"](#) on page 301.

18.7.1.1 Pin Control Register

Offset	See Table 18-2, "Register Summary"			
Bits	Description	Type	Default	Reset Event
31:25	RESERVED	RES	-	-
24	<p>GPIO input from pad</p> <p>On reads, Bit [24] reflects the state of GPIO input from the pad regardless of setting of Bit [10].</p> <p>Note: This bit is forced high when the selected power well is off as selected by the Power Gating Signal bits. See bits[3:2].</p>	R	Note 18-1	RESET_YS

MEC1725

Offset	See Table 18-2, "Register Summary"			
Bits	Description	Type	Default	Reset Event
23:17	RESERVED	RES	-	-
16	<p>GPIO output data</p> <p>If enabled by the GPIO Output Control Select bit, the GPIO output data bit determines the level on the GPIO pin when the pin is configured for the GPIO output function.</p> <p>On writes:</p> <p>If enabled via the GPIO Output Control Select</p> <p>0: GPIO[x] out = '0'</p> <p>1: GPIO[x] out = '1'</p> <p>Note: If disabled via the GPIO Output Control Select then the GPIO[x] out pin is unaffected by writing this bit.</p> <p>On reads:</p> <p>Bit [16] returns the last programmed value, not the value on the pin.</p>	<p>R/W (GPIO Output Control Select = 0)</p> <p>R (GPIO Output Control Select=1)</p>	Note 18-1	RESET_S YS
15	<p>GPIO input disable</p> <p>This bit can be used to support undervoltage functionality.</p> <p>1=disable input</p> <p>0=do not disable input</p>	R/W	Note 18-1	RESET_S YS
14:12	<p>Mux Control</p> <p>The Mux Control field determines the active signal function for a pin.</p> <p>000 = GPIO Function Selected</p> <p>001 = Signal Function 1 Selected</p> <p>010 = Signal Function 2 Selected</p> <p>011 = Signal Function 3 Selected</p> <p>100 = Signal Function 4 Selected</p> <p>101 = Signal Function 5 Selected if applicable for that GPIO, otherwise Reserved</p> <p>110 = Reserved</p> <p>111 = Reserved</p>	R/W	Note 18-1	RESET_S YS
11	<p>Polarity</p> <p>0 = Non-inverted</p> <p>1 = Inverted</p> <p>When the Polarity bit is set to '1' and the Mux Control bits are greater than '00,' the selected signal function outputs are inverted and Interrupt Detection (int_det) sense defined in Table 18-3, "Edge Enable and Interrupt Detection Bits Definition" is inverted. When the Mux Control field selects the GPIO signal function (Mux = '00'), the Polarity bit does not effect the output. Regardless of the state of the Mux Control field and the Polarity bit, the state of the pin is always reported without inversion in the GPIO input register.</p>	R/W	Note 18-1	RESET_S YS

Offset	See Table 18-2, "Register Summary"			
Bits	Description	Type	Default	Reset Event
10	<p>GPIO Output Control Select</p> <p>Every GPIO has two mechanisms to set a GPIO data output: Output GPIO Bit located in the grouped GPIO Output Registers and the single GPIO output data bit located in bit 16 of this register.</p> <p>This control bit determines the source of the GPIO output. 0 = Pin Control Bit[16] GPIO output data bit enabled When this bit is zero the single GPIO output data bit is enabled. (GPIO output data is R/W capable and the Grouped Output GPIO is disabled (i.e., Read-Only).</p> <p>1 = Grouped Output GPIO enable When this bit is one the GPIO output data write is disabled (i.e., Read-Only) and the Grouped Output GPIO is enabled (i.e., R/W).</p> <p>Note: See description in Section 18.6.1, "Accessing GPIOs".</p>	R/W	Note 18-1	RESET_S YS
9	<p>GPIO Direction</p> <p>0 = Input 1 = Output</p> <p>The GPIO Direction bit controls the buffer direction only when the Mux Control field is '00' selecting the pin signal function to be GPIO. When the Mux Control field is greater than '00' (i.e., a non-GPIO signal function is selected) the GPIO Direction bit has no affect and the selected signal function logic directly controls the pin direction.</p>	R/W	Note 18-1	RESET_S YS
8	<p>Output Buffer Type</p> <p>0 = Push-Pull 1 = Open Drain</p> <p>Note: Unless explicitly stated otherwise, pins with (I/O/OD) or (O/OD) in their buffer type column in the tables in are compliant with the following Programmable OD/PP Multiplexing Design Rule: Each compliant pin has a programmable open drain/push-pull buffer controlled by the Output Buffer Type bit in the associated Pin Control Register. The state of this bit controls the mode of the interface buffer for all selected functions, including the GPIO function.</p>	R/W	Note 18-1	RESET_S YS
7	<p>Edge Enable (edge_en)</p> <p>0 = Edge detection disabled 1 = Edge detection enabled</p> <p>Note: See Table 18-3, "Edge Enable and Interrupt Detection Bits Definition".</p>	R/W	Note 18-1	RESET_S YS

MEC1725

Offset	See Table 18-2, "Register Summary"			
Bits	Description	Type	Default	Reset Event
6:4	<p>Interrupt Detection (int_det)</p> <p>The interrupt detection bits determine the event that generates a GPIO_Event.</p> <p>Note: See Table 18-3, "Edge Enable and Interrupt Detection Bits Definition".</p> <p>Note: Since the GPIO input is always available, even when the GPIO is not selected as the alternate function, the GPIO interrupts may be used for detecting pin activity on alternate functions. The only exception to this is the analog functions (e.g., ADC inputs)</p>	R/W	Note 18-1	RESET_S YS
3:2	<p>Power Gating Signals (PGS)</p> <p>The Power Gating Signals provide the chip Power Emulation options. The pin will be tristated when the selected power well is off (i.e., gated) as indicated.</p> <p>The Emulated Power Well column defined in Pin Multiplexing indicates the emulation options supported for each signal. The Signal Power Well column defines the buffer power supply per function.</p> <p>Note: Note that all GPIOs support Power Gating unless otherwise noted.</p> <p>00 = VTR The output buffer is tristated when VTR_PWRGD = 0.</p> <p>01 = VCC The output buffer is tristate when VCC_PWRGD = 0.</p> <p>10 = Unpowered. The always unpowered setting on a GPIO will force the pin to tri-state. The input and output are disabled, and the pad is in the lowest power state.</p> <p>11 = Reserved</p> <p>Note: VBAT Powered Signals are always powered by the VBAT rail and power well emulation does not apply. For VBAT powered signals this field should be set to 00.</p>	R/W	Note 18-1	RESET_S YS
1:0	<p>PU/PD (PU_PD)</p> <p>These bits are used to enable an internal pull-up or pull-down resistor device on the pin.</p> <p>00 = None. Pin tristates when no active driver is present on the pin.</p> <p>01 = Pull Up Enabled</p> <p>10 = Pull Down Enabled</p> <p>11 = Repeater mode. Pin is kept at previous voltage level when no active driver is present on the pin.</p>	R/W	Note 18-1	RESET_S YS

Note 18-1 See [Section 3.5, "GPIO Register Assignments"](#) for the default values and [Table 18-2, "Register Summary"](#) and [Table 3-5, "Register Map"](#) for register offset value for each GPIO Pin Control Register.

Note 18-2 Repeater mode is not available on over voltage protected pins.

TABLE 18-3: EDGE ENABLE AND INTERRUPT DETECTION BITS DEFINITION

Edge Enable	Interrupt Detection Bits			Selected Function
	D7	D6	D5	
0	0	0	0	Low Level Sensitive
0	0	0	1	High Level Sensitive
0	0	1	0	Reserved
0	0	1	1	Reserved
0	1	0	0	Interrupt events are disabled
0	1	0	1	Reserved
0	1	1	0	Reserved
0	1	1	1	Reserved
1	1	0	1	Rising Edge Triggered
1	1	1	0	Falling Edge Triggered
1	1	1	1	Either Edge Triggered

Note: Only edge triggered interrupts can wake up the main ring oscillator. The GPIO must be enabled for edge-triggered interrupts and the GPIO interrupt must be enabled in the interrupt aggregator in order to wake up the ring when the ring is shut down.

APPLICATION NOTE:

1. All GPIO interrupt detection configurations default to '0000', which is low level interrupt. Having interrupt detection enabled will un-gated the clock to the GPIO module whenever the interrupt is active, which increases power consumption. Interrupt detection should be disabled when not required to save power.
2. Changing the configuration of the Interrupt edge and detection bits may generate an interrupt if it is enabled. The GPIO should be configured and associated status bits should be cleared before enabling the Interrupt.

MEC1725

18.7.1.2 Pin Control Register 2

Offset	See Note 18-1			
Bits	Description	Type	Default	Reset Event
31:6	Reserved	RES	-	-
5:4	DRIVE_STRENGTH These bits are used to select the drive strength on pad type PIO-12. See Note 2 . 00 = 2mA 01 = 4mA 10 = 8mA 11 = 12mA These bits are used to select the drive strength on pad type PIO-24. See Note 2 . 00 = 4mA 01 = 8mA 10 = 16mA 11 = 24mA	R/W	00	RESETSYS
3:1	Reserved	RES	-	-
0	SLEW_RATE (See Note 1) This bit is used to select the slew rate on the pin. 1=fast 0=slow (half frequency)	R/W	0h	RESETSYS
Note 1: eSPI pins do not support SLEW_RATE (See Note 1) control. 2: The drive strength is dependent on the Pad type define in Table 2-2, "MEC1725 176 WFBGA PIN MUX TABLE" of the Pin Chapter. See Electrical Specification Table 52-3, "DC Electrical Characteristics" for drive strength options per pad.				

18.7.2 GPIO OUTPUT REGISTERS

If enabled by the [GPIO Output Control Select](#) bit, the grouped GPIO Output bits determine the level on the GPIO pin when the pin is configured for the GPIO output function.

On writes:

If enabled via the [GPIO Output Control Select](#)

0: GPIO[x] out = '0'

1: GPIO[x] out = '1'

If disabled via the [GPIO Output Control Select](#) then the GPIO[x] out pin is unaffected by writing the corresponding GPIO bit in the grouped Output GPIO[xxx:yyy] register.

On reads:

The GPIO output bit in the grouped Output GPIO[xxx:yyy] register returns the last programmed value, not the value on the pin.

18.7.2.1 Output GPIO[000:036]

Offset	380h			
Bits	Description	Type	Default	Reset Event
31	RESERVED	RES	-	-
30:24	GPIO[036:030] Output	R/W	00h	RESET_S YS
23:16	GPIO[027:020] Output	R/W	00h	RESET_S YS
15:8	GPIO[017:010] Output	R/W	00h	RESET_S YS
7:0	GPIO[007:000] Output	R/W	00h	RESET_S YS

18.7.2.2 Output GPIO[040:076]

Offset	384h			
Bits	Description	Type	Default	Reset Event
31:24	RESERVED	RES	-	-
30:24	GPIO[076:070] Output	R/W	00h	RESET_S YS
23:16	GPIO[067:060] Output	R/W	00h	RESET_S YS
15:8	GPIO[057:050] Output	R/W	00h	RESET_S YS
7:0	GPIO[047:040] Output	R/W	00h	RESET_S YS

18.7.2.3 Output GPIO[100:127]

Offset	388h			
Bits	Description	Type	Default	Reset Event
31	RESERVED	RES	-	-
30:24	GPIO[136:130] Output	R/W	00h	RESET_S YS
23:16	GPIO[127:120] Output	R/W	00h	RESET_S YS

MEC1725

Offset	388h			
Bits	Description	Type	Default	Reset Event
15:8	GPIO[117:110] Output	R/W	00h	RESET_S YS
7:0	GPIO[107:100] Output	R/W	00h	RESET_S YS

18.7.2.4 Output GPIO[140:176]

Offset	38Ch			
Bits	Description	Type	Default	Reset Event
31	RESERVED	RES	-	-
30:24	GPIO[176:170] Output	R/W	00h	RESET_S YS
23:16	GPIO[167:160] Output	R/W	00h	RESET_S YS
15:8	GPIO[157:150] Output	R/W	00h	RESET_S YS
7:0	GPIO[147:140] Output	R/W	00h	RESET_S YS

18.7.2.5 Output GPIO[200:236]

Offset	390h			
Bits	Description	Type	Default	Reset Event
31	RESERVED	RES	-	-
30:24	GPIO[236:230] Output	R/W	00h	RESET_S YS
23:16	GPIO[227:220] Output	R/W	00h	RESET_S YS
15:8	GPIO[217:210] Output	R/W	00h	RESET_S YS
7:0	GPIO[207:200] Output	R/W	00h	RESET_S YS

18.7.2.6 Output GPIO[240:276]

Offset	394h			
Bits	Description	Type	Default	Reset Event
31	RESERVED	RES	-	-
30:24	GPIO[276:270] Output	R/W	00h	RESET_S YS
23:16	GPIO[267:260] Output	R/W	00h	RESET_S YS
15:8	GPIO[257:250] Output	R/W	00h	RESET_S YS
7:0	GPIO[247:240] Output	R/W	00h	RESET_S YS

18.7.3 GPIO INPUT REGISTERS

The [GPIO Input Registers](#) can always be used to read the state of a pin, even when the pin is in an output mode and/or when a signal function other than the GPIO signal function is selected; i.e., the [Pin Control Register Mux Control](#) bits are not equal to '00.'

The MSbit of the Input GPIO registers have been implemented as a read/write scratch pad bit to support processor specific instructions.

Note: Bits associated with GPIOs that are not implemented are shown as Reserved.

18.7.3.1 Input GPIO[000:036]

Offset	300h			
Bits	Description	Type	Default	Reset Event
31	Scratchpad Bit	R/W	0b	RESET_S YS
30:24	GPIO[036:030] Input	R	00h	RESET_S YS
23:16	GPIO[027:020] Input	R	00h	RESET_S YS
15:8	GPIO[017:010] Input	R	00h	RESET_S YS
7:0	GPIO[007:000] Input	R	00h	RESET_S YS

MEC1725

18.7.3.2 Input GPIO[040:076]

Offset	304h			
Bits	Description	Type	Default	Reset Event
31	Scratchpad Bit	R/W	0b	RESET_S YS
30:24	GPIO[076:070] Input	R	00h	RESET_S YS
23:16	GPIO[067:060] Input	R	00h	RESET_S YS
15:8	GPIO[057:050] Input	R	00h	RESET_S YS
7:0	GPIO[047:040] Input	R	00h	RESET_S YS

18.7.3.3 Input GPIO[100:127]

Offset	308h			
Bits	Description	Type	Default	Reset Event
31	Scratchpad Bit	R/W	0b	RESET_S YS
30:24	GPIO[136:130] Input	R	00h	RESET_S YS
23:16	GPIO[127:120] Input	R	00h	RESET_S YS
15:8	GPIO[117:110] Input	R	00h	RESET_S YS
7:0	GPIO[107:100] Input	R	00h	RESET_S YS

18.7.3.4 Input GPIO[140:176]

Offset	30Ch			
Bits	Description	Type	Default	Reset Event
31	Scratchpad Bit	R/W	0b	RESET_S YS
30:16	GPIO[176:160] Input	R	00h	RESET_S YS
15:8	GPIO[157:150] Input	R	00h	RESET_S YS
7:0	GPIO[147:140] Input	R	00h	RESET_S YS

18.7.3.5 Input GPIO[200:236]

Offset	310h			
Bits	Description	Type	Default	Reset Event
31	Scratchpad Bit	R/W	0b	RESET_S YS
30:24	GPIO[236:230] Input	R	00h	RESET_S YS
23:16	GPIO[227:220] Input	R	00h	RESET_S YS
15:8	GPIO[217:210] Input	R	00h	RESET_S YS
7:0	GPIO[207:200] Input	R	00h	RESET_S YS

18.7.3.6 Input GPIO[240:276]

Offset	314h			
Bits	Description	Type	Default	Reset Event
31	Scratchpad Bit	R/W	0b	RESET_S YS
30:24	GPIO[276:270] Input	R	00h	RESET_S YS

MEC1725

Offset	314h			
Bits	Description	Type	Default	Reset Event
23:16	GPIO[267:260] Input	R	00h	RESET_S YS
15:8	GPIO[257:250] Input	R	00h	RESET_S YS
7:0	GPIO[247:240] Input	R	00h	RESET_S YS

19.0 WATCHDOG TIMER (WDT)

19.1 Introduction

The function of the Watchdog Timer is to provide a mechanism to detect if the internal embedded controller has failed. When enabled, the Watchdog Timer (WDT) circuit will generate a [WDT Event](#) if the user program fails to reload the WDT within a specified length of time known as the WDT Interval.

19.2 Interface

This block is designed to be accessed internally via a registered host interface

19.3 Host Interface

FIGURE 19-1: I/O DIAGRAM OF BLOCK

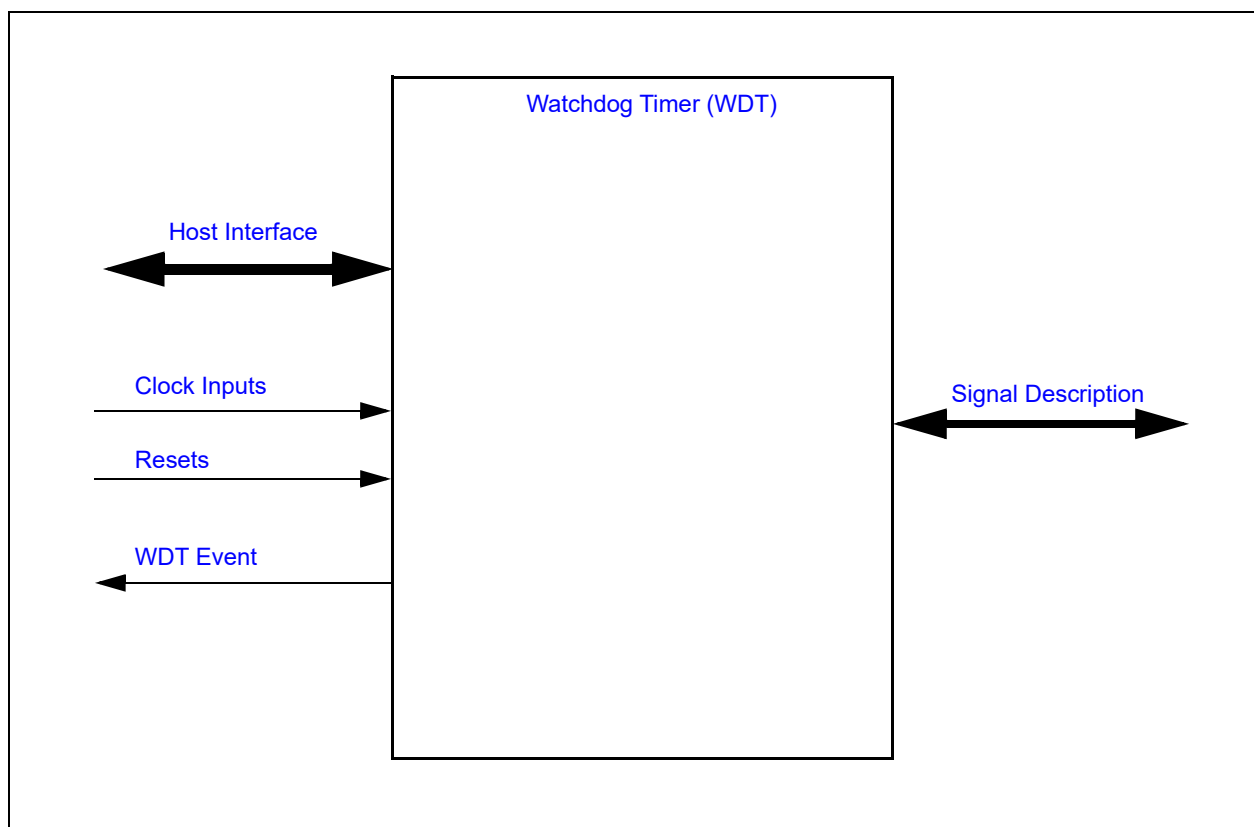

The registers defined for the [Watchdog Timer \(WDT\)](#) are accessible by the embedded controller as indicated in [Section 19.7, "EC Registers"](#). All registers accesses are synchronized to the host clock and complete immediately. Register reads/writes are not delayed by the [32KHz Core](#).

19.4 Signal Description

19.4.1 SIGNAL INTERFACE

There are no external signals for this block.

MEC1725

19.5 Power, Clocks and Reset

This section defines the Power, Clock, and Reset parameters of the block.

19.5.1 POWER DOMAINS

Name	Description
VTR_CORE	The logic and registers implemented in this block reside on this single power well.

19.5.2 CLOCK INPUTS

Name	Description
32KHz Core	The 32KHz Core clock input is the clock source to the Watchdog Timer functional logic, including the counter.

19.5.3 RESETS

TABLE 19-1: RESET INPUTS

Name	Description
RESET_SYS	Power on Reset to the block. This signal resets all the register and logic in this block to its default state following a POR or a WDT Event event.
RESET_SYS_nWDT	This reset signal is used on WDT registers/bits that need to be preserved through a WDT Event.

TABLE 19-2: RESET OUTPUTS

Source	Description
WDT Event	Pulse generated when WDT expires. This signal is used to either generate interrupt WDT_INT, if WDT Control Register bit 9 is set to 1b (WDT_INT_ENABLE), or reset the embedded controller and its subsystem, if WDT Control Register bit 9 is set to 0b. The event is cleared after a RESET_SYS.

19.6 Description

19.6.1 WDT OPERATION

19.6.1.1 WDT Activation Mechanism

The WDT is activated by the following sequence of operations during normal operation:

1. Load the WDT Load Register with the count value.
2. Set the WDT_ENABLE bit in the WDT Control Register.

The WDT Activation Mechanism starts the WDT decrementing counter.

19.6.1.2 WDT Deactivation Mechanism

The WDT is deactivated by the clearing the WDT_ENABLE bit in the WDT Control Register. The WDT Deactivation Mechanism places the WDT in a low power state in which clock are gated and the counter stops decrementing.

19.6.1.3 WDT Reload Mechanism

The WDT must be reloaded within periods that are shorter than the programmed watchdog interval; otherwise, the WDT will underflow and a [WDT Event](#) will be generated and the [WDT](#) bit in [Power-Fail and Reset Status Register on page 638](#) will be set. It is the responsibility of the user program to continually execute code which reloads the watchdog timer, causing the counter to be reloaded.

There are three methods of reloading the WDT: a write to the [WDT Load Register](#), a write to the [WDT Kick Register](#), or WDT event.

19.6.1.4 WDT Interval

The [WDT Interval](#) is the time it takes for the WDT to decrements from the [WDT Load Register](#) value to 0000h. The [WDT Count Register](#) value takes [33/32KHz Core](#) seconds (ex. $33/32.768 \text{ KHz} = 1.007\text{ms}$) to decrement by 1 count.

19.6.1.5 WDT STALL Operation

There are three STALL_ENABLE control bits in the [WDT Control Register](#). If enabled, and the STALL event is asserted, the WDT stops decrementing, and the WDT enters a low power state. When a WDT STALL event is de-asserted, the counter continues decrementing from the value it had when the STALL was asserted.

19.7 EC Registers

Registers for this block are shown in the following summary table. Addresses for each register are determined by adding the offset to the Base Address for each instance of the [Watchdog Timer \(WDT\)](#) Block in the Block Overview and Base Address Table in [Section 3.0, "Device Inventory"](#).

TABLE 19-3: REGISTER SUMMARY

Offset	Register Name
00h	WDT Load Register
04h	WDT Control Register
08h	WDT Kick Register
0Ch	WDT Count Register
10h	WDT Status Register
14h	WDT Int Enable Register

19.7.1 WDT LOAD REGISTER

Offset	00h			
Bits	Description	Type	Default	Reset Event
15:0	WDT_LOAD Writing this field reloads the Watch Dog Timer counter.	R/W	FFFFh	RESET_SYS

MEC1725

19.7.2 WDT CONTROL REGISTER

Offset	04h			
Bits	Description	Type	Default	Reset Event
31:10	Reserved	RES	-	-
9	WDT_RESET If the WDT_RESET bit is set and the watch dog timer expires, the Watch dog module will generate interrupt and the WDT_RESET bit will be cleared. If this bit is not set, when the watch dog timer expires EC and its subsystem is reset.	R/W	0b	RESET_SYS
8:5	Reserved	RES	-	-
4	JTAG_STALL This bit enables the WDT Stall function if JTAG or SWD debug functions are active 1=The WDT is stalled while either JTAG or SWD is active 0=The WDT is not affected by the JTAG debug interface	R/W	0b	RESET_SYS
3	WEEK_TIMER_STALL This bit enables the WDT Stall function if the Week Timer is active. 1=The WDT is stalled while the Week Timer is active 0=The WDT is not affected by the Week Timer	R/W	0b	RESET_SYS
2	HIBERNATION_TIMER_STALL This bit enables the WDT Stall function if the Hibernation Timer 0 or Hibernation Timer 1 is active. 1=The WDT is stalled while the Hibernation Timer 0 is active 0=The WDT is not affected by Hibernation Timer 0	R/W	0b	RESET_SYS
1	TEST	R	0b	RESET_SYS
0	WDT_ENABLE In WDT Operation , the WDT is activated by the sequence of operations defined in Section 19.6.1.1, "WDT Activation Mechanism" and deactivated by the sequence of operations defined in Section 19.6.1.2, "WDT Deactivation Mechanism" . 1=block enabled 0=block disabled	R/W	0b	RESET_SYS

19.7.3 WDT KICK REGISTER

Offset	08h			
Bits	Description	Type	Default	Reset Event
7:0	KICK The WDT Kick Register is a strobe. Reads of this register return 0. Writes to this register cause the WDT to reload the WDT Load Register value and start decrementing when the WDT_ENABLE bit in the WDT Control Register is set to '1'. When the WDT_ENABLE bit in the WDT Control Register is cleared to '0', writes to the WDT Kick Register have no effect.	W	n/a	RESET_SYS

19.7.4 WDT COUNT REGISTER

Offset	0Ch			
Bits	Description	Type	Default	Reset Event
15:0	WDT_COUNT This read-only register provide the current WDT count.	R	FFFFh	RESET_SYS

19.7.5 WDT STATUS REGISTER

Offset	10h			
Bits	Description	Type	Default	Reset Event
31:1	Reserved	RES	-	-
0	WDT_EVENT_IRQ This bit indicates the status of interrupt from Watch dog module.	R/W1C	0h	RESET_SYS-nWDT

MEC1725

19.7.6 WDT_INT_ENABLE REGISTER

Offset	14h			
Bits	Description	Type	Default	Reset Event
31:1	Reserved	RES	-	-
0	WDT_INT_ENABLE This is the interrupt enables bit for WDT_INT interrupt. 1b - WDT_INT Interrupt Enable 0b - WDT_INT Interrupt Disabled	R/W	0h	RESET _SYS- _nWDT

20.0 16/32 BIT BASIC TIMER

20.1 Introduction

This timer block offers a simple mechanism for firmware to maintain a time base. This timer may be instantiated as 16 bits or 32 bits. The name of the timer instance indicates the size of the timer.

20.2 Interface

This block is designed to be accessed internally via a registered host interface.

FIGURE 20-1: I/O DIAGRAM OF BLOCK

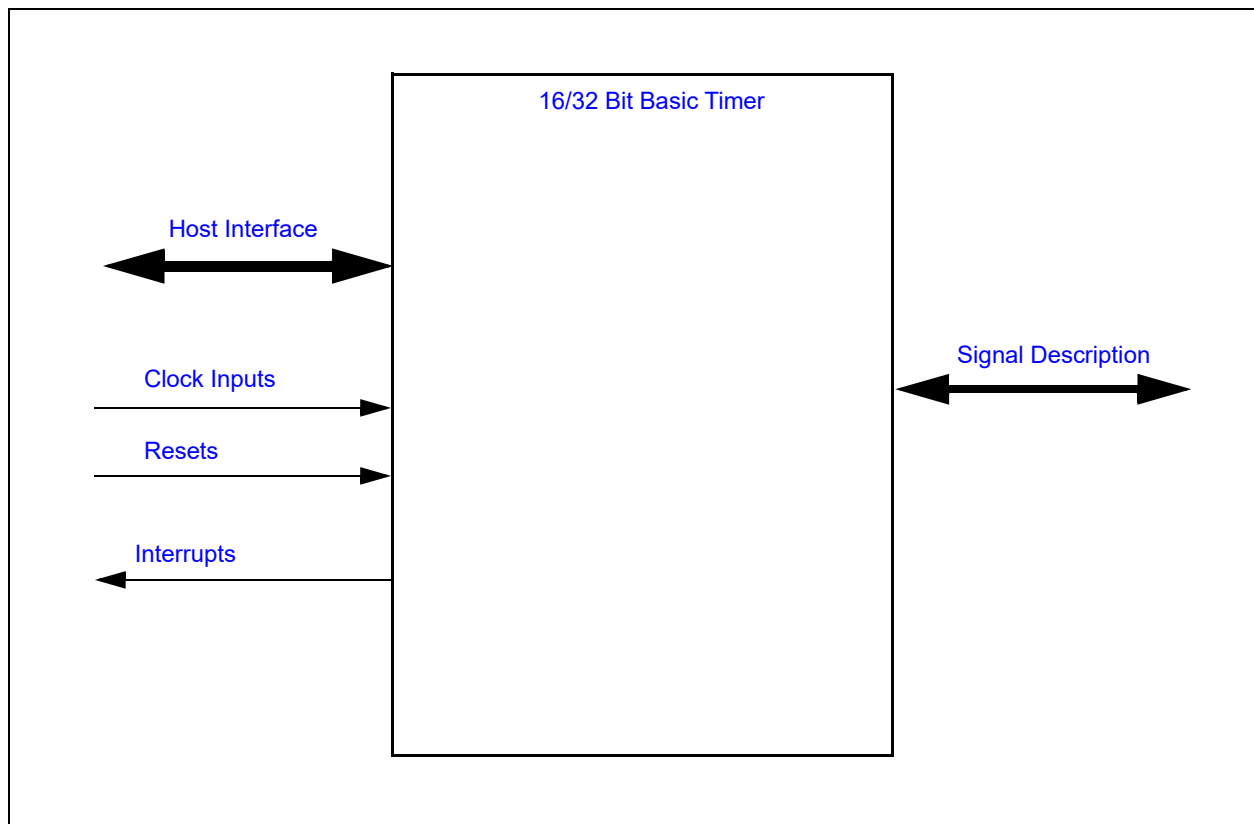

20.3 Signal Description

There are no external signals for this block.

20.4 Host Interface

The Embedded Controller (EC) may access this block via the registers defined in [Section 20.9, "EC-Only Registers," on page 323](#).

20.5 Power, Clocks and Reset

This section defines the Power, Clock, and Reset parameters of the block.

MEC1725

20.5.1 POWER DOMAINS

TABLE 20-1: POWER SOURCES

Name	Description
VTR_CORE	The timer control logic and registers are all implemented on this single power domain.

20.5.2 CLOCK INPUTS

TABLE 20-2: CLOCK INPUTS

Name	Description
48MHz	This is the clock source to the timer logic. The Pre-scaler may be used to adjust the minimum resolution per bit of the counter.

20.5.3 RESETS

TABLE 20-3: RESET SIGNALS

Name	Description
RESET_SYS	This reset signal, which is an input to this block, resets all the logic and registers to their initial default state.
SOFT_RESET	This reset signal, which is created by this block, resets all the logic and registers to their initial default state. This reset is generated by the block when the SOFT_RESET bit is set in the Timer Control Register register.
Timer_Reset	This reset signal, which is created by this block, is asserted when either the RESET_SYS or the SOFT_RESET signal is asserted. The RESET_SYS and SOFT_RESET signals are OR'd together to create this signal.

20.6 Interrupts

TABLE 20-4: EC INTERRUPTS

Source	Description
TIMER_16_x	This interrupt event fires when a 16-bit timer x reaches its limit. This event is sourced by the EVENT_INTERRUPT status bit if enabled.
TIMER_32_x	This interrupt event fires when a 32-bit timer x reaches its limit. This event is sourced by the EVENT_INTERRUPT status bit if enabled.

Note: x represents the instance number.

20.7 Low Power Modes

The Basic Timer may be put into a low power state by the chip's Power, Clocks, and Reset (PCR) circuitry. This block is only be permitted to enter low power modes when the block is not active.

The sleep state of this timer is as follows:

- Asleep while the block is not Enabled
- Asleep while the block is not running (start inactive).
- Asleep while the block is halted (even if running).

The block is active while start is active.

20.8 Description

FIGURE 20-2: BLOCK DIAGRAM

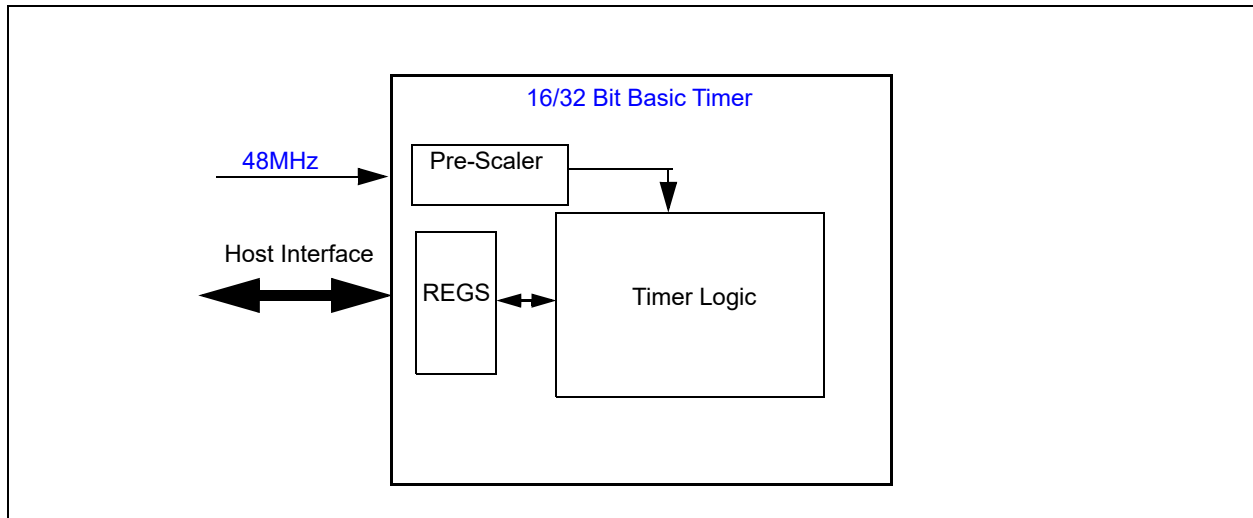

This timer block offers a simple mechanism for firmware to maintain a time base in the design. The timer may be enabled to execute the following features:

- Programmable resolution per LSB of the counter via the Pre-scale bits in the Timer Control Register
- Programmable as either an up or down counter
- One-shot or Continuous Modes
- In one-shot mode the Auto Restart feature stops the counter when it reaches its limit and generates a level event.
- In Continuous Mode the Auto Restart feature restarts that counter from the programmed preload value and generates a pulse event.
- Counter may be reloaded, halted, or started via the Timer Control register
- Block may be reset by either a Power On Reset (POR) or via a Soft Reset.

20.9 EC-Only Registers

The registers listed in the EC-Only Register Summary table are for a single instance of the Basic Timer. The addresses of each register listed in this table are defined as a relative offset to the “Base Address” of that instance, defined in the Device Inventory chapter and will follow the instance naming as listed in **TABLE 20-5: “MEC1725 Instance Naming Convention”**.

TABLE 20-5: MEC1725 INSTANCE NAMING CONVENTION

Block Instance	Host
16-Bit Basic Timer x	EC
32-Bit Basic Timer x	EC
Note: x represents the instance number.	

TABLE 20-6: RUNTIME REGISTER SUMMARY

Offset	Register Name
00h	Timer Count Register
04h	Timer Preload Register
08h	Timer Status Register
0Ch	Timer Int Enable Register
10h	Timer Control Register

20.9.1 TIMER COUNT REGISTER

Offset	00h			
Bits	Description	Type	Default	Reset Event
31:0	<p>COUNTER</p> <p>This is the value of the Timer counter. This is updated by Hardware but may be set by Firmware. If it is set while the Hardware Timer is operating, functionality can not be guaranteed. When read, it is buffered so single byte reads will be able to catch the full 4 byte register without it changing.</p> <ul style="list-style-type: none"> - For 16 bit Basic Timer, bits 0 to 15 are r/w counter bits. Bits 31 down to 16 are reserved. Reads of bits 31 down to 16 return 0 and writes have no effect. - For 32 bit Basic Timer, bits 0 to 31 are r/w counter bits. 	R/W	0h	Tim-er_Re-set

20.9.2 TIMER PRELOAD REGISTER

Offset	04h			
Bits	Description	Type	Default	Reset Event
31:0	<p>PRE_LOAD</p> <p>This is the value of the Timer pre-load for the counter. This is used by H/W when the counter is to be restarted automatically; this will become the new value of the counter upon restart.</p> <p>The size of the Pre-Load value is the same as the size of the counter.</p> <ul style="list-style-type: none"> - For 16 bit Basic Timer, bits 0 to 15 are r/w pre-load bits. Bits 31 down to 16 are reserved. Reads of bits 31 down to 16 return 0 and writes have no effect. - For 32 bit Basic Timer, bits 0 to 31 are r/w pre-load bits. 	R/W	0h	Timer_Reset

20.9.3 TIMER STATUS REGISTER

Offset	08h			
Bits	Description	Type	Default	Reset Event
31:0	Reserved	RES	-	-
0	<p>EVENT_INTERRUPT</p> <p>This is the interrupt status that fires when the timer reaches its limit. This may be level or a self clearing signal cycle pulse, based on the AUTO_RESTART bit in the Timer Control Register. If the timer is set to automatically restart, it will provide a pulse, otherwise a level is provided.</p>	R/WC	0h	Timer_Reset

20.9.4 TIMER INT ENABLE REGISTER

Offset	0Ch			
Bits	Description	Type	Default	Reset Event
31:0	Reserved	RES	-	-
0	<p>EVENT_INTERRUPT_ENABLE</p> <p>This is the interrupt enable for the status EVENT_INTERRUPT bit in the Timer Status Register</p>	R/W	0h	Timer_Reset

MEC1725

20.9.5 TIMER CONTROL REGISTER

Offset	10h			
Bits	Description	Type	Default	Reset Event
31:16	<p>PRE_SCALE</p> <p>This is used to divide down the system clock through clock enables to lower the power consumption of the block and allow slow timers. Updating this value during operation may result in erroneous clock enable pulses until the clock divider restarts.</p> <p>The number of clocks per clock enable pulse is (Value + 1); a setting of 0 runs at the full clock speed, while a setting of 1 runs at half speed.</p>	R/W	0h	Timer_Reset
15:8	Reserved	RES	-	-
7	<p>HALT</p> <p>This is a halt bit. This will halt the timer as long as it is active. Once the halt is inactive, the timer will start from where it left off.</p> <p>1=Timer is halted. It stops counting. The clock divider will also be reset.</p> <p>0=Timer runs normally</p>	R/W	0h	Timer_Reset
6	<p>RELOAD</p> <p>This bit reloads the counter without interrupting its operation. This will not function if the timer has already completed (when the START bit in this register is '0'). This is used to periodically prevent the timer from firing when an event occurs. Usage while the timer is off may result in erroneous behavior.</p>	R/W	0h	Timer_Reset
5	<p>START</p> <p>This bit triggers the timer counter. The counter will operate until it hits its terminating condition. This will clear this bit. It should be noted that when operating in restart mode, there is no terminating condition for the counter, so this bit will never clear. Clearing this bit will halt the timer counter.</p> <p>Setting this bit will:</p> <ul style="list-style-type: none"> ■ Reset the clock divider counter. ■ Enable the clock divider counter. ■ Start the timer counter. ■ Clear all interrupts. <p>Clearing this bit will:</p> <ul style="list-style-type: none"> ■ Disable the clock divider counter. ■ Stop the timer counter. 	R/W	0h	Timer_Reset
4	<p>SOFT_RESET</p> <p>This is a soft reset.</p> <p>This is self-clearing 1 cycle after it is written.</p>	WO	0h	Timer_Reset
3	<p>AUTO_RESTART</p> <p>This will select the action taken upon completing a count.</p> <p>1=The counter will automatically restart the count, using the contents of the Timer Preload Register to load the Timer Count Register. The interrupt will be set in edge mode.</p> <p>0=The counter will simply enter a done state and wait for further control inputs. The interrupt will be set in level mode.</p>	R/W	0h	Timer_Reset

Offset	10h			
Bits	Description	Type	Default	Reset Event
2	<p>COUNT_UP This selects the counter direction.</p> <p>When the counter in incrementing the counter will saturate and trigger the event when it reaches all F's. When the counter is decrementing the counter will saturate when it reaches 0h.</p> <p>1=The counter will increment 0=The counter will decrement</p>	R/W	0h	Timer_Reset
1	Reserved	RES	-	-
0	<p>ENABLE This enables the block for operation.</p> <p>1=This block will function normally 0=This block will gate its clock and go into its lowest power state</p>	R/W	0h	Timer_Reset

21.0 16-BIT COUNTER-TIMER INTERFACE

21.1 Introduction

The [16-Bit Counter-Timer Interface](#) implements four 16-bit auto-reloading timer/counters. The clock for each timer/counter is derived from the system clock and can be divided down by a prescaler. Input-Only and Input/Output timers can also use an external input pin to clock or gate the counter. To aid operation in noisy environments the external input pin also has a selectable noise filter. If large counts are required, the output of each timer/counter can be internally connected to the next timer/counter.

21.2 References

No references have been cited for this feature.

21.3 Terminology

TABLE 21-1: TERMINOLOGY

Term	Definition
Overflow	When the timer counter transitions from FFFFh to 0000h
Underflow	When the timer counter transitions from 0000h to FFFFh.
Timer Tick Rate	This is the rate at which the timer is incremented or decremented.

21.4 Interface

This block is designed to be accessed externally via the pin interface and internally via a registered host interface.

FIGURE 21-1: I/O DIAGRAM OF BLOCK

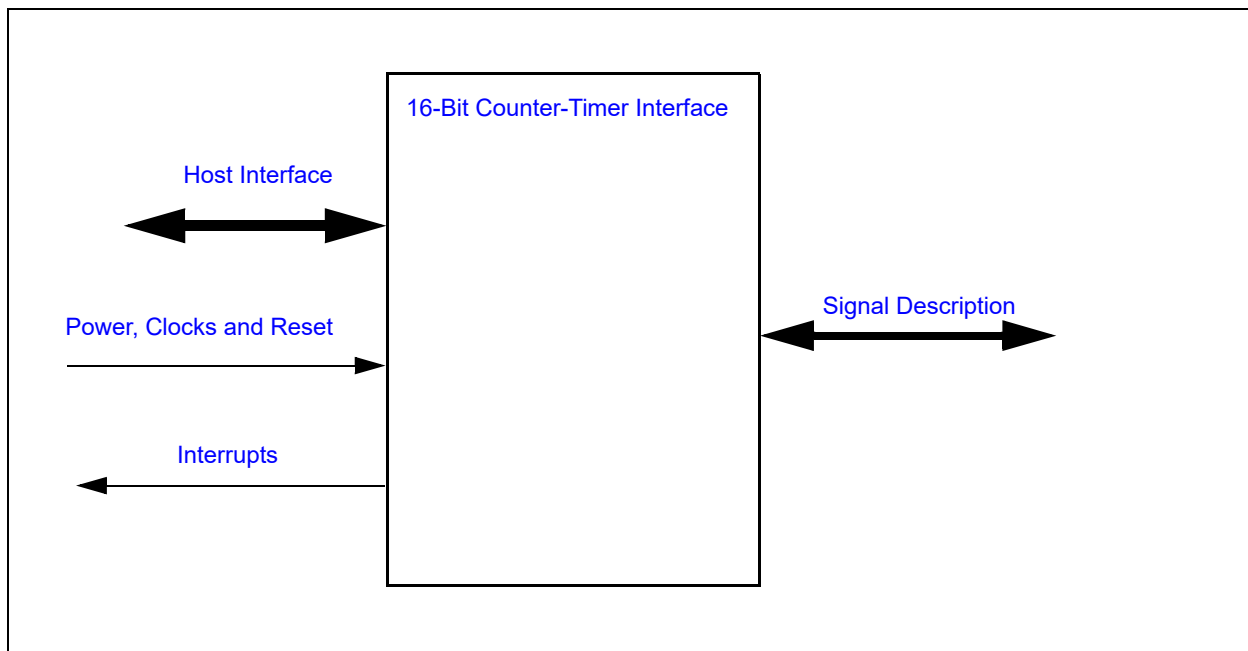

21.5 Signal Description

TABLE 21-2: SIGNAL DESCRIPTION TABLE

Name	Direction	Description
TINx	INPUT	Timer x Input signal
TOUTx	OUTPUT	Timer x Output signal

21.6 Host Interface

The registers defined for 16-bit Timers are accessible by the various hosts as indicated in [Section 21.11, "EC Registers"](#).

21.7 Power, Clocks and Reset

This section defines the Power, Clock, and Reset parameters of the block.

21.7.1 POWER DOMAINS

Name	Description
VTR_CORE	The logic and registers implemented in this block are powered by this power well.

21.7.2 CLOCK INPUTS

Name	Description
48MHz	This is the clock source for this block.

21.7.3 RESETS

Name	Description
RESET_SYS	This signal resets all the registers and logic in this block to their default state.
Soft Reset	This reset signal, which is created by this block, resets all the logic and registers to their initial default state. This reset is generated by the block when the RESET bit is set in the Timer x Control Register .
Reset_Timer	This reset signal, which is created by this block, is asserted when either the RESET_SYS or the Soft Reset signal is asserted. The RESET_SYS and Soft Reset signals are OR'd together to create this signal.

21.8 Interrupts

This section defines the Interrupt Sources generated from this block.

Source	Description
TIMERx	This interrupt event fires when a 16-bit timer x overflows or underflows.

MEC1725

21.9 Low Power Modes

The 16-bit Timer may be put into a low power state by the chip's Power, Clocks, and Reset (PCR) circuitry. This block is only be permitted to enter low power modes when the block is not active. The block is inactive in the following conditions:

- The block is not running (**ENABLE** de-asserted)
- The block is powered down (**PD** asserted).

The timer requires one Timer Clock period to halt after receiving a Sleep_En signal. When the block returns from sleep, if enabled, it will be restarted from the preload value.

21.10 Description

FIGURE 21-2: BLOCK DIAGRAM FOR TIMER X

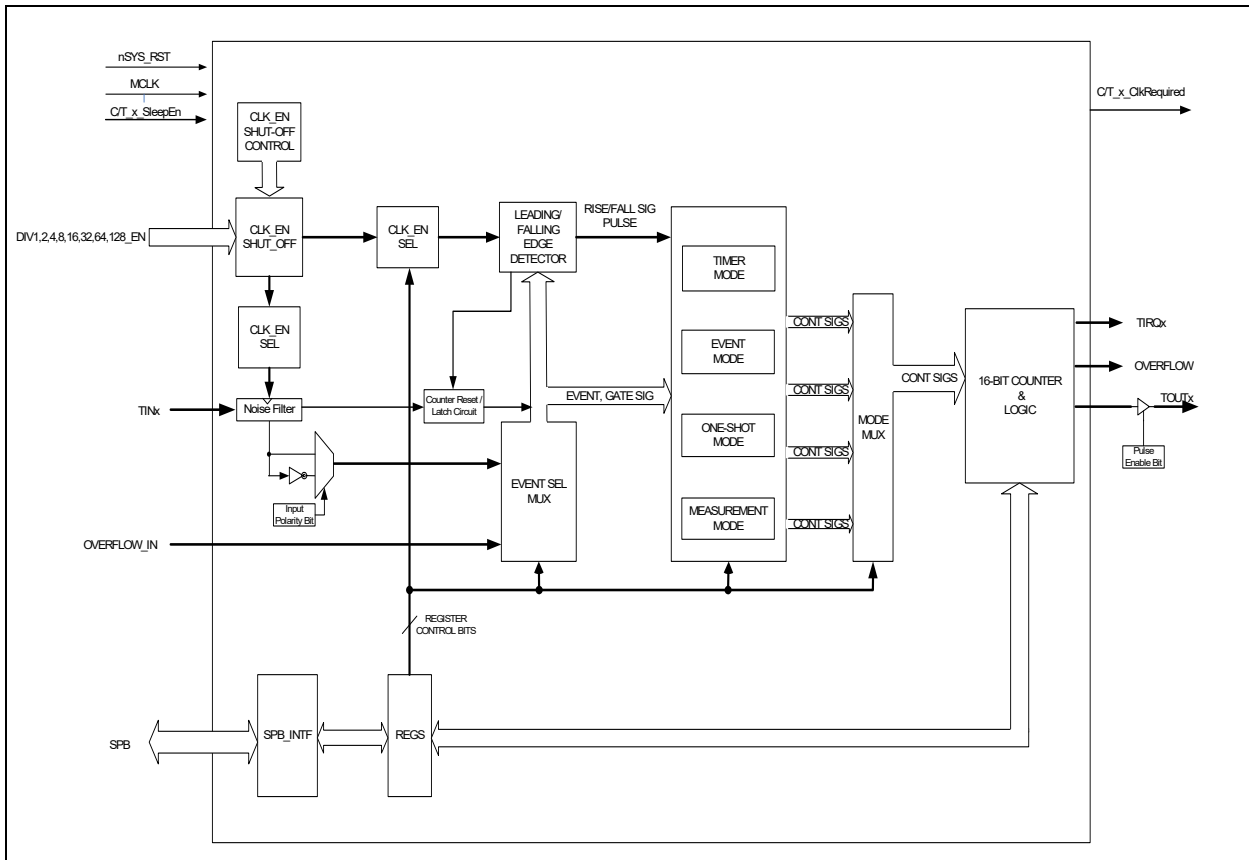

The 16-bit Timer consists of a 16-bit counter, clocked by a by a configurable Timer Clock. The Timer can operate in any of 4 Modes: **Timer Mode**, **Event Mode**, **One-Shot Mode**, and **Measurement Mode**. The Timer can be used to generate an interrupt to the EC. Depending on the mode, the Timer can also generate an output signal.

21.10.1 TIMER CLOCK

Any of the frequencies listed in [Table 21-3](#) may be used as the time base for the 16-bit counter.

TABLE 21-3: TIMER CLOCK FREQUENCIES

Timer Clock Select	Frequency Divide Select	Frequency Selected
0000b	Divide by 1	48MHz
0001b	Divide by 2	24MHz
0010b	Divide by 4	12MHz

TABLE 21-3: TIMER CLOCK FREQUENCIES (CONTINUED)

Timer Clock Select	Frequency Divide Select	Frequency Selected
0011b	Divide by 8	6MHz
0100b	Divide by 16	3MHz
0101b	Divide by 32	1.5MHz
0110b	Divide by 64	750KHz
0111b	Divide by 128	375KHz
1xxx b	Reserved	Reserved

For the Timer Clock, the **Timer Clock Select** value is defined by the **TCLK** field in the [Timer x Clock and Event Control Register](#)

21.10.2 FILTER CLOCK AND NOISE FILTER

The noise filter uses the Filter Clock (FCLK) to filter the signal on the **TINx** pins. for Event Mode and One-Shot Mode.

In Event Mode, the Event input is synchronized to FCLK and (if enabled) filtered by a three stage filter. The resulting recreated clock is used to clock the timer in Event mode. In Bypass Mode, configured by the **FILTER_BYPASS** bit in the [Timer x Control Register](#), the pulse width of the external signal must be at least 2x the pulse width of the FCLK source. In Filter Mode, the pulse width of the external signal must be at least 4x the pulse width of the sync and filter clock

In One-Shot mode, the TIN duration could be smaller than a TCLK period. The filtered signal is latched until the signal is seen in the TCLK domain. This also applies in the filter bypass mode

Frequencies for the Filter Clock are the as those available for the Timer Clock, and are listed in [Table 21-3](#). For the Filter Clock, the **Timer Clock Select** value is defined by the **FCLK** field in the [Timer x Clock and Event Control Register](#). The choice of frequency is independent of the value chosen for the Timer Clock.

21.10.3 TIMER CONNECTIONS

For external inputs/outputs (**TINx/TOUTx**) to/from timers, please see Pin Configuration chapter for a description of the 16-bit Counter/Timer Interface.

TABLE 21-4: TIMER CASCADING DESCRIPTION

Timer Name	Timer Type	Over-Flow/ Under-flow Input's Connection
Timer 0	General Purpose	from Timer 3
Timer 1	General Purpose	from Timer 0
Timer 2	General Purpose	from Timer 1
Timer 3	General Purpose	from Timer 2

Note: The cascading connections are independent of the **TINx/TOUTx** connections.

21.10.4 STARTING AND STOPPING

The 16-bit timers can be started and stopped by setting and clearing the **ENABLE** bit in the [Timer x Control Register](#) in all modes, except one-shot.

21.10.5 TIMER MODE

Timer mode is used to generate periodic interrupts to the EC. When operating in this mode the timer always counts down based on one of the internally generated clock sources. The Timer mode is selected by setting the Timer Mode Select bits in the Timer Control Register. See [Section 21.11.1, "Timer x Control Register"](#).

The period between timer interrupts and the width of the output pulse is determined by the speed of the clock source, the clock divide ratio and the value programmed into the Timer Reload Register. The timer clock source and clock rate are selected using the Clock Source Select bits (**TCLK**) in the [Timer x Clock and Event Control Register](#). See [Section 21.11.2, "Timer x Clock and Event Control Register"](#).

TABLE 21-5: TIMER MODE OPERATIONAL SUMMARY

Item	Description
Timer Clock Frequencies	This mode supports all the programmable frequencies listed in Table 21-3, "Timer Clock Frequencies"
Filter Clock Frequencies	This mode supports all the programmable frequencies listed in Table 21-3, "Timer Clock Frequencies"
Count Operation	Down Counter
Reload Operation	When the timer underflows: RLOAD = 1, timer reloads from Timer Reload Reg RLOAD = 0, timer rolls over to FFFFh.
Count Start Condition	UPDN = 0 (timer only mode): ENABLE = 1 UPDN = 1 (timer gate mode): ENABLE = 1 & TIN = 1;
Count Stop Condition	UPDN = 0: ENABLE = 0; UPDN = 1: (ENABLE = 0 TIN = 0)
Interrupt Request Generation Timing	When timer underflows from 0000h to reload value (as determined by RLOAD) an interrupt is generated.
TINx Pin Function	Provides timer gate function
TOUTx Pin Function	TOUT toggles each time the timer underflows (if enabled).
Read From Timer	Current count value can be read by reading the Timer Count Register
Write to Preload Register	After the firmware writes to the Timer Reload Register asserting the RESET loads the timer with the new value programmed in the Timer Reload Register. Note: If the firmware does not assert RESET, the timer will automatically load the Timer Reload Register value when the timer underflows. When the timer is running, values written to the Timer Reload Register are written to the timer counter when the timer underflows. The assertion of Reset also copies the Timer Reload Register into the timer counter.
Selectable Functions	<ul style="list-style-type: none"> • Reload timer on underflow with programmed Preload value (Basic Timer) • Reload timer with FFFFh in Free Running Mode (Free-running Timer) • Timer can be started and stopped by the TINx input pin (Gate Function) • The TOUTx pin changes polarity each time the timer underflows (Pulse Output Function)

21.10.5.1 Timer Mode Underflow

The timer operating in Timer mode can underflow in two different ways. One method, the Reload mode shown in [Figure 21-3](#), is to reload the value programmed into the Reload register and continue counting from this value. The second method, Free Running mode [Figure 21-4](#), is to set the timer to FFFFh and continue counting from this value. The underflow behavior is controlled by the **RLOAD** bit in the Timer Control Register.

FIGURE 21-3: RELOAD MODE BEHAVIOR

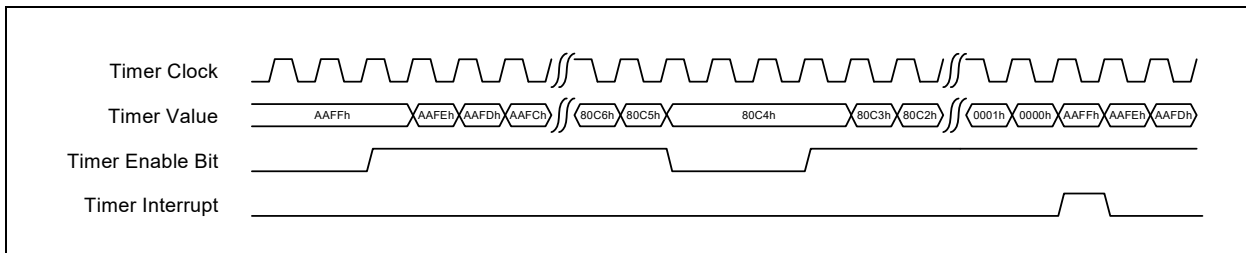
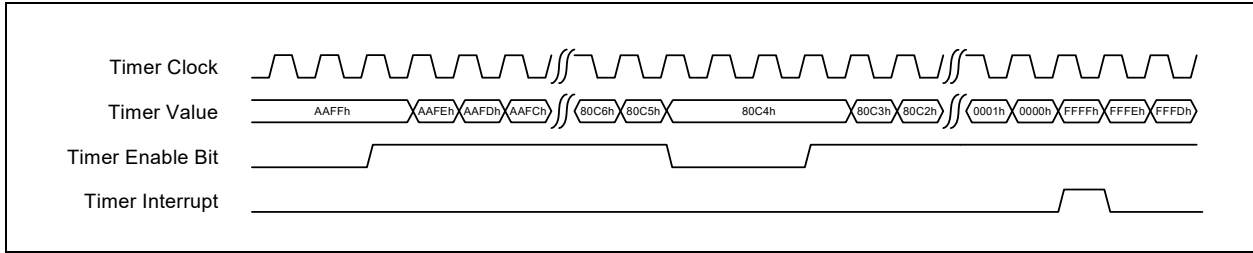

FIGURE 21-4: FREE RUNNING MODE BEHAVIOR



21.10.5.2 Timer Gate Function

The TIN pin on each timer can be used to pause the timer's operation when the timer is running. The timer will stop counting when the TIN pin is deasserted and count when the TIN pin is asserted. Figure 21-5 shows the timer behavior when the TIN pin is used to gate the timer function. The UPDN bit is used to enable and disable the Timer Gate function when in the Timer mode.

FIGURE 21-5: TIMER GATE OPERATION

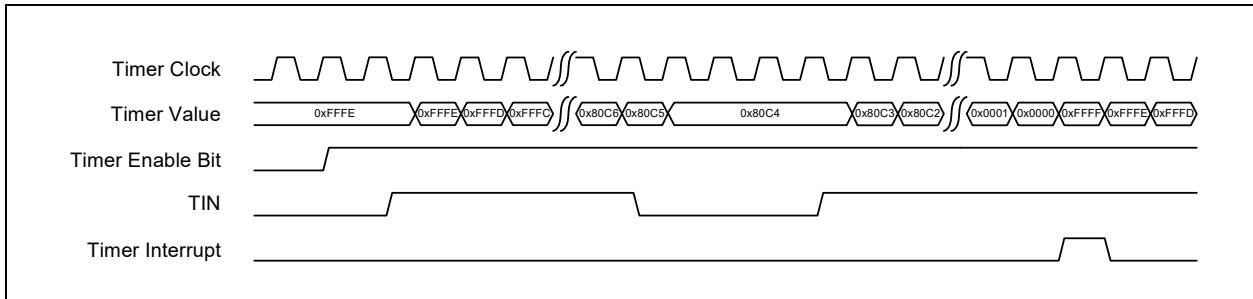

21.10.5.3 Timer Mode Pulse Output

The four Timers can be used to generate a periodic output pulse. The output pulse changes state each time the timer underflows. The output is also cleared when the EN bit is cleared. Figure 21-6 shows the behavior of the TOUTx pin when it is used as a pulse output pin.

FIGURE 21-6: TIMER PULSE OUTPUT

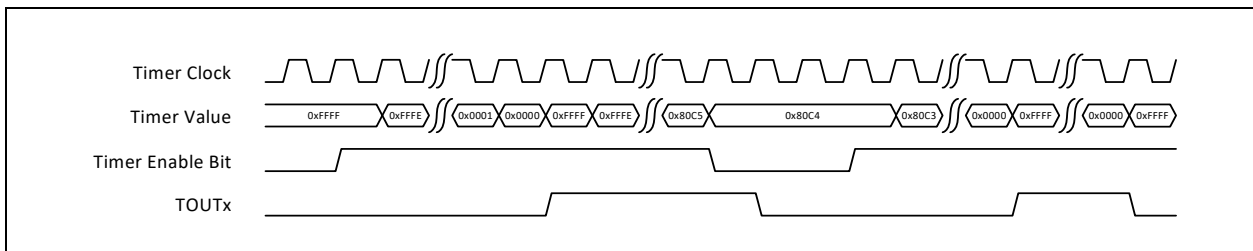

21.10.6 EVENT MODE

Event mode is used to count events that occur external to the timer. The timer can be programmed to count the overflow output from the previous timer or an edge on the TIN pin. The direction the timer counts in Event mode is controlled by the UPDN bit in the Timer Control Register. When the timer is in Event mode, the TOUTx signal can be used to generate a periodic output pulse when the timer overflows or underflows. Figure 21-6 illustrates the pulse output behavior of the TOUTx pin in event mode when the timer underflows.

MEC1725

The timer can be programmed using the Clock and Event Control register to respond to the following events using the [EVENT](#) bits and the [EDGE](#) bits: rising edge of TINx, falling edge of TINx, rising and falling edge of TINx, rising edge of overflow input, falling edge of the overflow input, and the rising and falling edges of the overflow input.

TABLE 21-6: EVENT MODE OPERATIONAL SUMMARY

Item	Description
Count Source	<ul style="list-style-type: none">External signal input to TINx pin (effective edge can be selected by software)Timer x-1 overflow
Timer Clock Frequencies	This mode supports all the programmable frequencies listed in Table 21-3, "Timer Clock Frequencies"
Filter Clock Frequencies	This mode supports all the programmable frequencies listed in Table 21-3, "Timer Clock Frequencies"
Count Operation	Up/Down Counter
Reload Operation	<ul style="list-style-type: none">When the timer underflows: RLOAD = 1, timer reloads from Timer Reload Reg RLOAD = 0, timer rolls over to FFFFh.When the timer overflows: RLOAD = 1, timer reloads from Timer Reload Reg RLOAD = 0, timer rolls over to 0000h.
Count Start Condition	Timer Enable is set (ENABLE = 1)
Count Stop Condition	Timer Enable is cleared (ENABLE = 0)
Interrupt Request Generation Timing	When timer overflows or underflows
TINx Pin Function	Event Generation
TOUTx Pin Function	TOUT toggles each time the timer underflows/overflows (if enabled).
Read From Timer	Current count value can be read by reading the Timer Count Register
Write to Preload Register	After the firmware writes to the Timer Reload Register, asserting the RESET loads the timer with the new value programmed in the Timer Reload Register. Note: If the firmware does not assert RESET, the timer will automatically load the Timer Reload Register value when the timer underflows.
Selectable Functions	<ul style="list-style-type: none">The direction of the counter is selectable via the UPDN bit.Reload timer on underflow/overflow with programmed Preload value (Basic Timer)Reload timer with FFFFh in Free Running Mode (Free-running Timer)Pulse Output Function The TOUTx pin changes polarity each time the timer underflows or overflows.

21.10.6.1 Event Mode Operation

The timer starts counting events when the [ENABLE](#) bit in the Timer Control Register is set and continues to count until the [ENABLE](#) bit is cleared. When the [ENABLE](#) bit is set, the timer continues counting from the current value in the timer except after a reset event. After a reset event, the timer always starts counting from the value programmed in the Reload Register if counting down or from 0000h if counting up. [Figure 21-7](#) shows an example of timer operation in Event mode. The RLOAD bit controls the behavior of the timer when it underflows or overflows.

FIGURE 21-7: EVENT MODE OPERATION

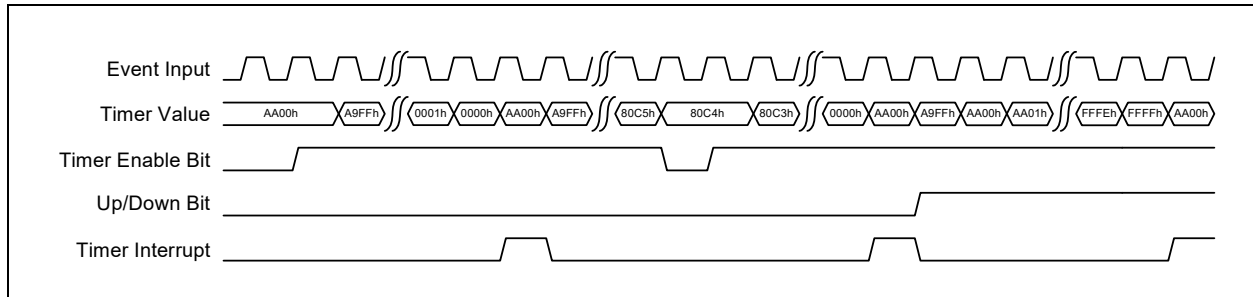

21.10.7 ONE-SHOT MODE

The One-Shot mode of the timer is used to generate a single interrupt to the EC after a specified amount of time. The timer can be configured to start using the **ENABLE** bit (Figure 21-8) or on a timer overflow event from the previous timer. See Section 21.11.2, "Timer x Clock and Event Control Register" for configuration details. The **ENABLE** bit must be set for an event to start the timer. The **ENABLE** bit is cleared one clock after the timer starts. The timer always starts from the value in the Reload Register and counts down in One-Shot mode.

TABLE 21-7: ONE SHOT MODE OPERATIONAL SUMMARY

Item	Description
Timer Clock Frequencies	This mode supports all the programmable frequencies listed in Table 21-3, "Timer Clock Frequencies"
Filter Clock Frequencies	This mode supports all the programmable frequencies listed in Table 21-3, "Timer Clock Frequencies"
Count Operation	Down Counter
Reload Operation	When the timer underflows the timer will stop. When the timer is enabled timer starts counting from value programmed in Timer Reload Register. (RLOAD has no effect in this mode)
Count Start Condition	Setting the ENABLE bit to 1 starts One-Shot mode. The timer clock automatically clears the enable bit one timer tick later. One-Shot mode may be enabled in Event Mode. In Event mode an overflow from the previous timer is used for timer tick rate.
Count Stop Condition	<ul style="list-style-type: none"> • Timer is reset (RESET = 1) • Timer underflows
Interrupt Request Generation Timing	When an underflow occurs.
TINx Pin Function	One Shot External input
TOUTx Pin Function	The TOUTx pin is asserted when the timer starts and de-asserted when the timer stops
Read From Timer	Current count value can be read by reading the Timer Count Register
Write to Preload Register	After the firmware writes to the Timer Reload Register, asserting the RESET loads the timer with the new value programmed in the Timer Reload Register. Note: If the firmware does not assert RESET, the timer will automatically load the Timer Reload Register value when the timer underflows.
Selectable Functions	<ul style="list-style-type: none"> • Pulse Output Function The TOUTx pin is asserted when the timer starts and de-asserted when the timer stops.

FIGURE 21-8: TIMER START BASED ON ENABLE BIT

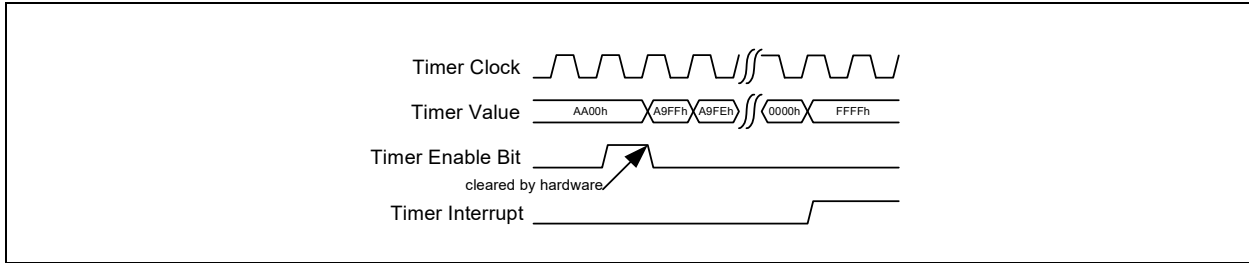

FIGURE 21-9: TIMER START BASED ON EXTERNAL EVENT

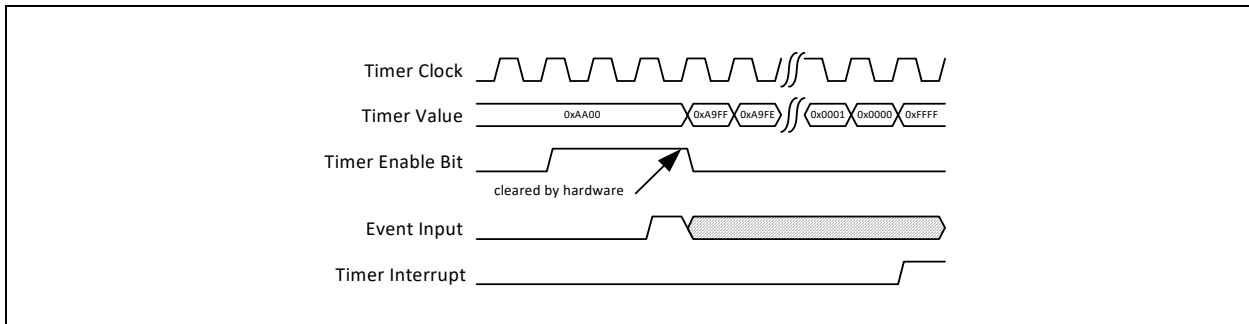
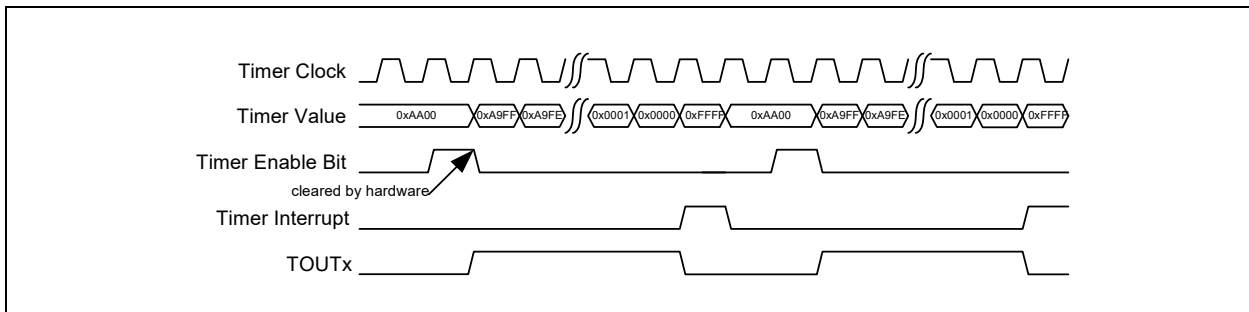

FIGURE 21-10: ONE SHOT TIMER WITH PULSE OUTPUT



21.10.8 MEASUREMENT MODE

The Measurement mode is used to measure the pulse width or period of an external signal. An interrupt to the EC is generated after each measurement or if the timer overflows and no measurement occurred. The timer measures the pulse width or period by counting the number of clock between edges on the TINx pin. The timer always starts counting at zero and counts up to 0xFFFF. The accuracy of the measurement depends on the speed of the clock being used. The speed of the clock also determines the maximum pulse width or period that can be detected.

TABLE 21-8: MEASUREMENT MODE OPERATIONAL SUMMARY

Item	Description
Timer Clock Frequencies	This mode supports all the programmable frequencies listed in Table 21-3, "Timer Clock Frequencies"
Filter Clock Frequencies	This mode supports all the programmable frequencies listed in Table 21-3, "Timer Clock Frequencies"

TABLE 21-8: MEASUREMENT MODE OPERATIONAL SUMMARY (CONTINUED)

Item	Description
Count Operation	<ul style="list-style-type: none"> Up Count At measurement pulse's effective edge, the count value is transferred to the Timer Reload Register and the timer is loaded with 0000h and continues counting.
Count Start Condition	<ul style="list-style-type: none"> Timer enable is set (ENABLE = 1)
Count Stop Condition	<ul style="list-style-type: none"> Timer is reset (RESET = 1) Timer overflows Timer enable is cleared (ENABLE = 0)
Interrupt Request Generation Timing	<ul style="list-style-type: none"> When timer overflows When a measurement pulse's effective edge is input. (An interrupt is not generated on the first effective edge after the timer is started.)
TINx Pin Function	Programmable Input port or Measurement input
Read From Timer	When the Timer x Reload Register is read it indicates the measurement result from the last measurement made. The Timer x Reload Register reads 0000h if the timer overflows before a measurement is made.
Write to Timer	Timer x Reload Register is Read-Only in Measurement mode

21.10.8.1 Pulse Width Measurements

The timers measure pulse width by counting the number of timer clocks since the last rising or falling edge of the TINx input. To measure the pulse width of a signal on the TINx pin, the **EDGE** bits in the Clock and Event Control Register, must be set to start counting on rising and falling edges. The timer starts measuring on the next edge (rising or falling) on the TINx pin after the **ENABLE** bit is set. The Reload register stores the result of the last measurement taken. If the timer overflows, 0x0000 is written to the Reload register and the **ENABLE** bit is cleared stopping the timer. **Figure 21-11** shows the timer behavior when measuring pulse widths.

The timer will not assert an interrupt in Pulse Measurement mode until the timer detects both a rising and a falling edge.

FIGURE 21-11: PULSE WIDTH MEASUREMENT

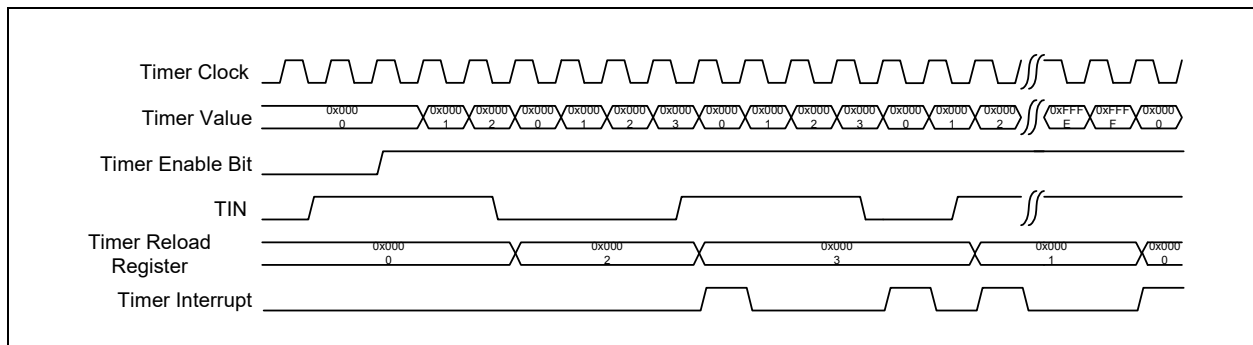

21.10.8.2 Period Measurements

The 16-bit timer measures the period of a signal by counting the number of timer clocks between either rising or falling edges of the TINx input. The measurement edge is determined by the **EDGE** bits in the Clock and Event Control Register. The timer starts measuring on the next edge (rising or falling) on the TINx pin after the **ENABLE** bit is set. The reload register stores the result of the last measurement taken. If the timer overflows, 0x0000 is written to the reload register. **Figure 21-12** shows the timer behavior when measuring the period of a signal.

The timer will not signal an interrupt in period measurement mode until the timer detects either two rising edges or two falling edges.

FIGURE 21-12: PULSE PERIOD MEASUREMENT

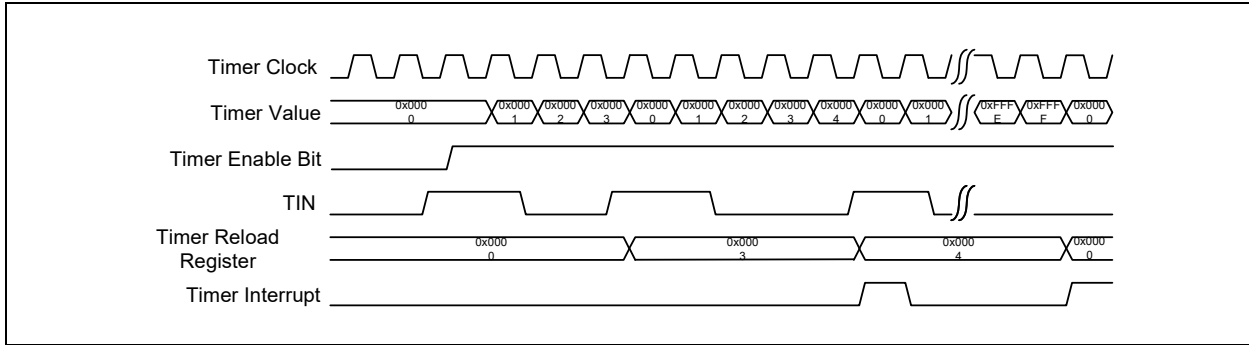

21.11 EC Registers

Registers for this block are shown in the following summary table. Addresses for each register are determined by adding the offset to the Base Address for each instance of the [16-Bit Counter-Timer Interface](#) Block in the Block Overview and Base Address Table in [Section 3.0, "Device Inventory"](#).

TABLE 21-9: REGISTER SUMMARY

Offset	Register Name
00h	Timer x Control Register
04h	Timer x Clock and Event Control Register
08h	Timer x Reload Register
0Ch	Timer x Count Register

21.11.1 TIMER X CONTROL REGISTER

Offset	00h			
Bits	Description	Type	Default	Reset Event
31:13	Reserved	R	-	-
12	<p>TIMERX_CLK_REQ</p> <p>This bit reflects the current state of the timer's Clock_Required output signal.</p> <p>1=The main clock is required by this block 0=The main clock is not required by this block</p>	R	0h	Reset_Timer
11	<p>SLEEP_ENABLE</p> <p>This bit reflects the current state of the timer's Sleep_Enable input signal.</p> <p>1=Normal operation 0=Sleep Mode is requested</p>	R	0h	Reset_Timer

Offset	00h			
Bits	Description	Type	Default	Reset Event
10	TOUT_POLARITY This bit determines the polarity of the TOUTx output signal. In timer modes that toggle the TOUTx signal, this polarity bit will not have a perceivable difference, except to determine the inactive state. In One-Shot mode this determines if the pulsed output is active high or active low. 1=Active low 0=Active high	R/W	0h	Reset_Timer
9	PD Power Down. 1=The timer is powered down and all clocks are gated 0=The timer is in a running state	R/W	1h	Reset_Timer
8	FILTER_BYPASS This bit is used to enable or disable the noise filter on the TINx input signal. 1=IBypass Mode: input filter disabled. The TINx input directly affects the timer 0=Filter Mode: input filter enabled. The TINx input is filtered by the input filter	R/W	0h	Reset_Timer
7	RLOAD Reload Control. This bit controls how the timer is reloaded on overflow or underflow in Event and Timer modes. It has no effect in One Shot mode. 1=Reload timer from Timer Reload Register and continue counting 0=Roll timer over to FFFFh and continue counting when counting down and rolls over to 0000h and continues counting when counting up	R/W	0h	Reset_Timer
6	TOUT_EN This bit enables the TOUTx pin 1=TOUTx pin function is enabled 0=TOUTx pin is inactive	R/W	0h	Reset_Timer
4	UPDN In Event Mode, this bit selects the timer count direction. In Timer Mode enables timer control by the TINx input pin. Event Mode: 1=The timer counts up 0=The timer counts down Timer Mode: 1=TINx pin pauses the timer when de-asserted 0=TINx pin has no effect on the timer	R/W	0h	Reset_Timer

MEC1725

Offset	00h			
Bits	Description	Type	Default	Reset Event
4	<p>INPOL</p> <p>This bit selects the polarity of the TINx input</p> <p>1=TINx is active low 0=TINx is active high</p>	R/W	0h	Reset_Timer
3:2	<p>MODE</p> <p>Timer Mode.</p> <p>3=Measurement Mode 2=One Shot Mode 1=Event Mode 0=Timer Mode</p>	R/W	0h	Reset_Timer
1	<p>RESET</p> <p>This bit stops the timer and resets the internal counter to the value in the Timer Reload Register. This bit also clears the ENABLE bit if it is set. This bit is self-clearing after the timer is reset.</p> <p>Firmware must poll the RESET bit in order to determine when the timer is active after reset. The polling time may be any value from 0 ms to $2^{(TCLK+1)}/48MHz$. If it the TCLK value was set to 0111b then the polling time will be a 5.33us (typ). Worst case polling time is dependent on accuracy of 48MHz clock source.</p> <p>Interrupts are blocked only when RESET takes effect and the ENABLE bit is cleared. If interrupts are not desired, firmware must mask the interrupt in the interrupt block.</p> <p>1=Timer reset 0=Normal timer operation</p>	R/W	0h	Reset_Timer
0	<p>ENABLE</p> <p>This bit is used to start and stop the timer. This bit does not reset the timer count but does reset the timer pulse output. This bit will be cleared when the timer stops counting in One-Shot mode.</p> <p>The ENABLE bit is cleared after a RESET cycle has completed. Firmware must poll the RESET bit in order to determine when the timer is active after reset.</p> <p>1=Timer is enabled 0=Timer is disabled</p>	R/W	0h	Reset_Timer

21.11.2 TIMER X CLOCK AND EVENT CONTROL REGISTER

Offset	04h			
Bits	Description	Type	Default	Reset Event
31:12	Reserved	R	-	-
11:8	FCLK Timer Clock Select. This field determines the clock source for the TINx noise filter. See Section 21.10.2, "Filter Clock and Noise Filter" for a description of the available frequencies. The available frequencies are the same as for TCLK.	R/W	0h	Reset_Timer
7	EVENT Event Select. This bit is used to select the count source when the timer is operating in Event Mode. 1=TINx is count source 0=Timer x-1 overflow is count source	R/W	0h	Reset_Timer
6:5	EDGE This field selects which edge of the TINx input signal affects the timer in Event Mode, One-Shot Mode and Measurement Mode. Event Mode: 11b=No event selected 10b=Counts rising and falling edges 01b=Counts rising edges 00b=Counts falling edges One-Shot Mode: 11b=Start counting when the Enable bit is set 10b=Starts counting on a rising or falling edge 01b=Starts counting on a rising edge 00b=Starts counting on a falling edge Measurement Mode: 11b=No event selected 10b=Measures the time between rising edges and falling edges and the time between falling edges and rising edges 01b=Measures the time between rising edges 00b=Measures the time between falling edges	R/W	0h	Reset_Timer
4	Reserved	R	-	-
3:0	TCLK Timer Clock Select. This field determines the clock source for the 16-bit counter in the timer. See Section 21.10.1, "Timer Clock" for a description of the available frequencies.	R/W	0h	Reset_Timer

MEC1725

21.11.3 TIMER X RELOAD REGISTER

Offset	08h			
Bits	Description	Type	Default	Reset Event
31:16	Reserved	R	-	-
15:0	TIMER_RELOAD The Timer Reload register is used in Timer and One-Shot modes to set the lower limit of the timer. In Event mode the Timer Reload register sets either the upper or lower limit of the timer depending on if the timer is counting up or down. Valid Timer Reload values are 0001h - FFFFh. If the timer is running, the reload value will not be updated until the timer overflows or underflows. Programming a 0000h as a preload value is not a valid count value. Using a value of 0000h will cause unpredictable behavior.	R/W	FFFFh	Reset_Timer

21.11.4 TIMER X COUNT REGISTER

Offset	0Ch			
Bits	Description	Type	Default	Reset Event
31:16	Reserved	R	-	-
15:0	TIMER_COUNT The Timer Count register returns the current value of the timer in all modes.	R	FFFFh	Reset_Timer

22.0 INPUT CAPTURE AND COMPARE TIMER

22.1 Introduction

The Input Capture and Compare Timers block contains a 32-bit timer running at the main system clock frequency. The timer is free-running and is associated with six 32-bit capture registers and two compare registers. Each capture register can record the value of the free-running timer based on a programmable edge of its associated input pin. An interrupt can be generated for each capture register each time it acquires a new timer value. The timer can also generate an interrupt when it automatically resets and can additionally generate two more interrupts when the timer matches the value in either of two 32-bit compare registers.

22.2 Interface

This block is designed to be accessed externally via the pin interface and internally via a registered host interface.

FIGURE 22-1: I/O DIAGRAM OF BLOCK

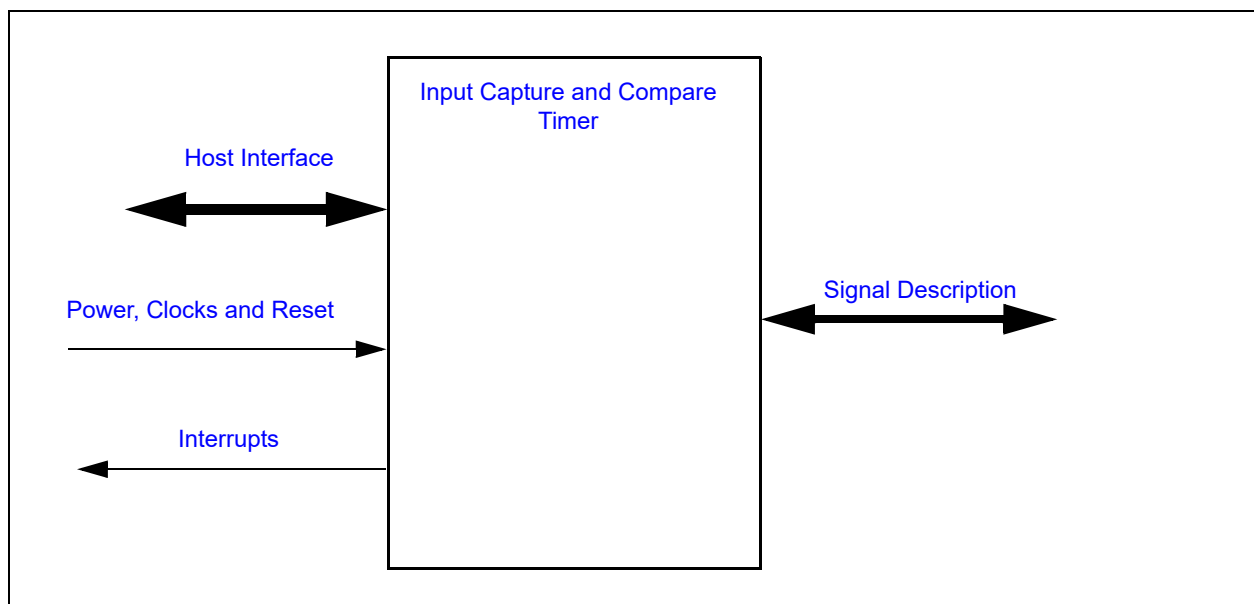

22.3 Signal Description

TABLE 22-1: SIGNAL DESCRIPTION

Name	Direction	Description
ICTx	INPUT	External capture trigger signal for Capture Register.
CTOUT0	OUTPUT	External compare match signal for Compare Register 0
CTOUT1	OUTPUT	External compare match signal for Compare Register 1
Note: Any ICTx can be connected to any Capture register using the ICT MUX Select Register .		

22.4 Host Interface

The registers defined for 16-bit Timers are accessible by the various hosts as indicated in [Section 3.2, "Block Overview and Base Addresses"](#).

MEC1725

22.5 Power, Clocks and Reset

This section defines the Power, Clock, and Reset parameters of the block.

22.5.1 POWER DOMAINS

Name	Description
VTR_CORE	The logic and registers implemented in this block are powered by this power well.

22.5.2 CLOCK INPUTS

Name	Description
48MHz	This is the clock source for this block.

22.5.3 RESETS

Name	Description
RESET_SYS	This signal resets all the registers and logic in this block to their default state.

22.6 Interrupts

This section defines the Interrupt Sources generated from this block.

Source	Description
CAPTURE TIMER	This interrupt event fires when the 32-bit free running counter overflows from FFFF_FFFFh to 0000_0000h.
CAPTURE 0	This interrupt event fires when Capture Register 0 acquires a new value.
CAPTURE 1	This interrupt event fires when Capture Register 1 acquires a new value.
CAPTURE 2	This interrupt event fires when Capture Register 2 acquires a new value.
CAPTURE 3	This interrupt event fires when Capture Register 3 acquires a new value.
CAPTURE 4	This interrupt event fires when Capture Register 4 acquires a new value.
CAPTURE 5	This interrupt event fires when Capture Register 5 acquires a new value.
COMPARE 0	This interrupt event fires when the contents of Compare 0 Register match the contents of the Free Running Counter.
COMPARE 1	This interrupt event fires when the contents of Compare 1 Register match the contents of the Free Running Counter.

22.7 Low Power Modes

The Capture and Compare Timer may be put into a low power state by the chip's Power, Clocks, and Reset (PCR) circuitry. This block is only be permitted to enter low power modes when the block is not active. The block is inactive if the [ACTIVATE](#) bit is de-asserted, and will also become inactive when the block's SLEEP_EN signal is asserted.

When the block returns from sleep, if enabled, the Free Running Timer Register value will continue counting from where it was when the block entered the Sleep state.

22.8 Description

The [Input Capture and Compare Timer](#) block has [ICT Channels](#) inputs and these can be connected to any of the 6 Capture Compare timer as shown in **FIGURE 22-2: “Capture and Compare Timer Port Connectivity”**

Note: The CCT0 to CCT5 blocks shown in **FIGURE 22-2: “Capture and Compare Timer Port Connectivity”** are expanded and shown in **FIGURE 22-3: “Capture and Compare Timer Block Diagram”**

FIGURE 22-2: CAPTURE AND COMPARE TIMER PORT CONNECTIVITY

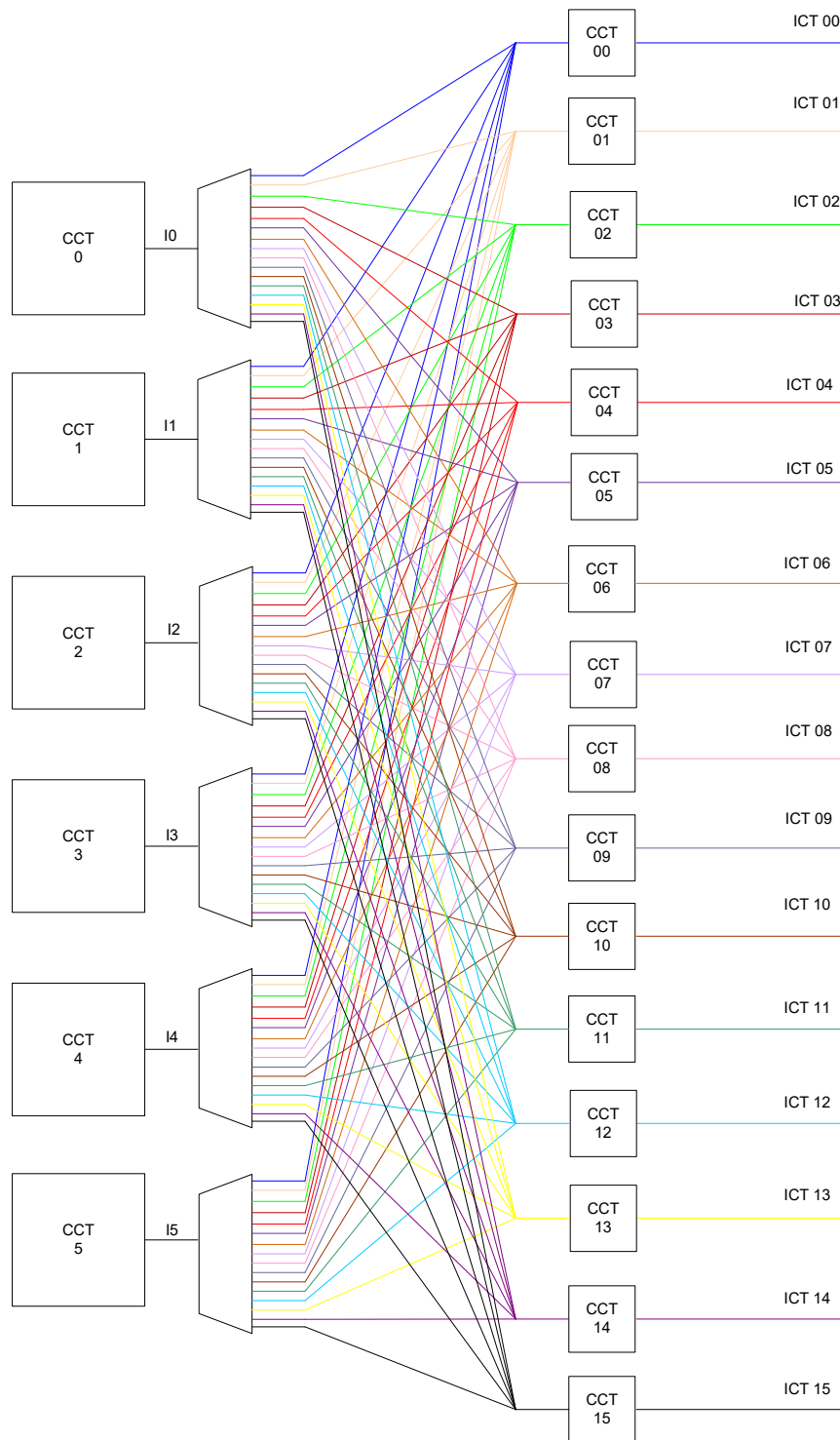
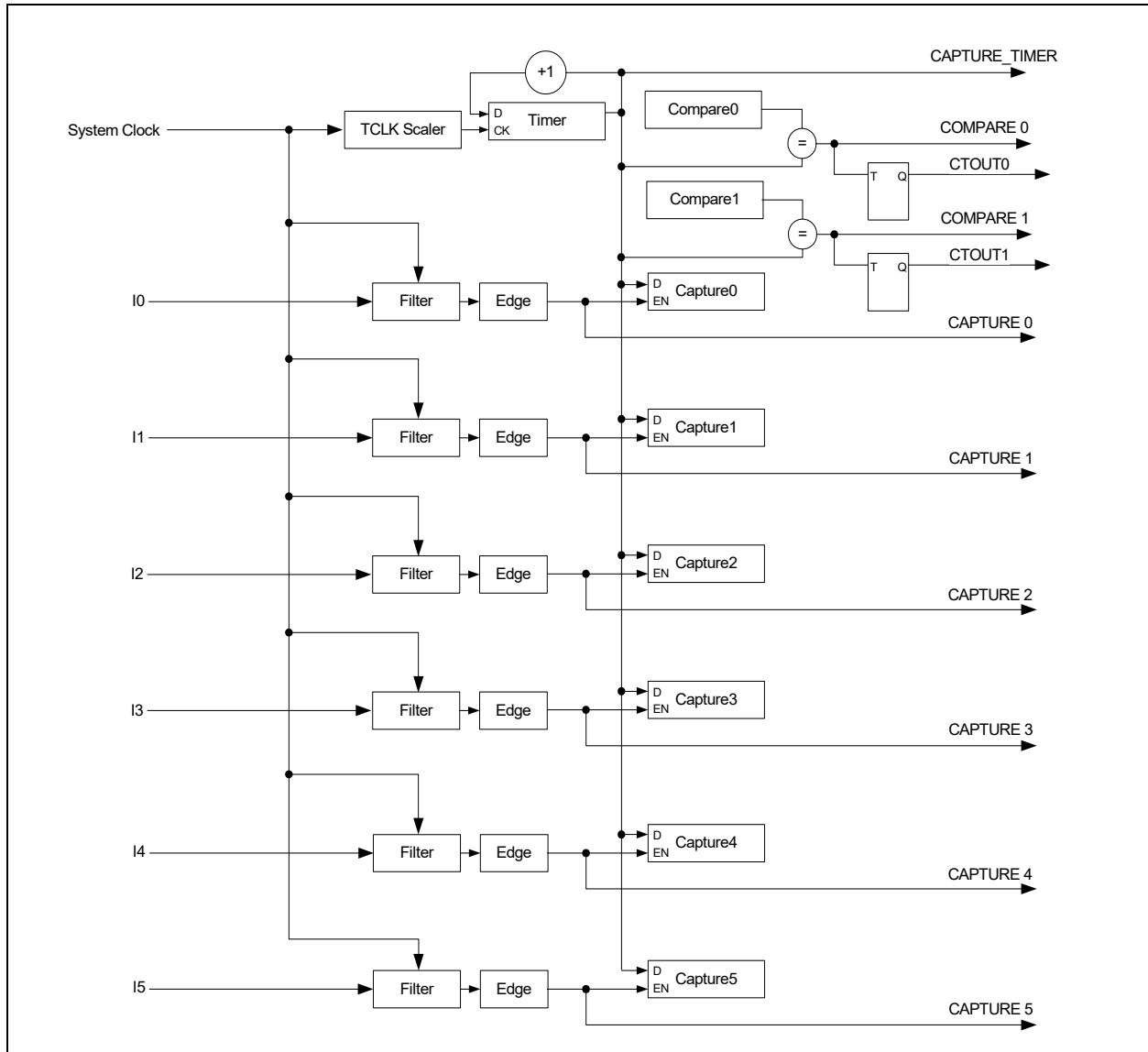

FIGURE 22-3: CAPTURE AND COMPARE TIMER BLOCK DIAGRAM



22.8.1 TIMER CLOCK

Any of the frequencies listed in [Table 22-2](#) may be used as the time base for the Free Running Counter.

TABLE 22-2: TIMER CLOCK FREQUENCIES

Timer Clock Select	Frequency Divide Select	Frequency Selected
0000b	Divide by 1	48MHz
0001b	Divide by 2	24MHz
0010b	Divide by 4	12MHz
0011b	Divide by 8	6MHz
0100b	Divide by 16	3MHz
0101b	Divide by 32	1.5MHz
0110b	Divide by 64	750KHz

TABLE 22-2: TIMER CLOCK FREQUENCIES (CONTINUED)

Timer Clock Select	Frequency Divide Select	Frequency Selected
0111b	Divide by 128	375KHz
1xxxb	Reserved	Reserved

For the Timer Clock, the **Timer Clock Select** value is defined by the **TCLK** field in the [Capture and Compare Timer Control Register](#)

22.8.2 FILTER CLOCK AND NOISE FILTER

The noise filter uses the Filter Clock (FCLK) to filter the signal on the Input Capture pins. An Input Capture pin must remain in the same state for three FCLK ticks before the internal state changes. The **FILTER_BYPASS** bit for the Input Capture pin may be used to bypass the input filter. Each Capture Register can individually bypass the filter.

When the input filter is bypassed, the minimum period of FCLK must be at least 2X the duration of an input signal pulse in order for an edge event to be captured reliably. When the input filter is enabled, the minimum period of FCLK must be at least 4X the duration of an input signal pulse in order for an edge event to be captured reliably.

22.9 Operation

22.9.1 INPUT CAPTURE

The Input Capture block consists of a free-running 32-bit timer and 2 capture registers. Each of the capture registers is associated with an input pin as well as an interrupt source bit in the Interrupt Aggregator. The Capture registers store the current value of the Free Running timer whenever the associated input signal changes, according to the programmed edge detection. An interrupt is also generated to the EC. The Capture registers are read-only. The registers are updated every time an edge is detected. If software does not read the register before the next edge, the value is lost.

22.9.2 COMPARE TIMER

There are two 32-bit Compare registers. Each of these registers can independently generate an interrupt to the EC when the 32-bit Free Running Timer matches the contents of the Compare register. The compare operation for each is enabled or disabled by a bit in the [Capture and Compare Timer Control Register](#).

22.9.2.1 Interrupt Generation

Whenever a Compare Timer is enabled and the Compare register matches the Free Running Timer, a COMPARE event is sent to the Interrupt Aggregator. The event will trigger an EC interrupt if enabled by the appropriate Interrupt Enable register in the Aggregator.

22.9.2.2 Compare Output Generation

Each Compare Timer is associated with a toggle flip-flop. When the 32-bit Free Running Timer matches the contents of the Compare register the output off the flip-flop is complemented. Each of the toggle flip-flops can be independently set or cleared by using the **COMPARE_SET** or **COMPARE_CLEAR** fields, respectively, in the [Capture and Compare Timer Control Register](#).

A Compare Timer should be disabled before setting or clearing the output, when updating the Compare register, or when updating the Free Running Timer, so spurious events are not generated by the matcher.

22.10 EC Registers

Registers for this block are shown in the following summary table. Addresses for each register are determined by adding the offset to the Base Address for each instance of the [Input Capture and Compare Timer](#) Block in the Block Overview and Base Address Table in [Section 3.0, "Device Inventory"](#).

Note: All registers in this block must be accessed as DWORDS.

TABLE 22-3: REGISTER SUMMARY

Offset	Register Name
00h	Capture and Compare Timer Control Register
04h	Capture Control 0 Register
08h	Capture Control 1 Register
0Ch	Free Running Timer Register
10h	Capture 0 Register
14h	Capture 1 Register
18h	Capture 2 Register
1Ch	Capture 3 Register
20h	Capture 4 Register
24h	Capture 5 Register
28h	Compare 0 Register
2Ch	Compare 1 Register
30h	ICT MUX Select Register

22.10.1 CAPTURE AND COMPARE TIMER CONTROL REGISTER

Note: It is not recommended to use Read-Modify-Write operations on this register. May inadvertently cause the COMPARE_SET and COMPARE_CLEAR bits to be written to '1' in error.

Offset	00h			
Bits	Description	Type	Default	Reset Event
31:26	Reserved	RES	-	-
25	<p>COMPARE_CLEAR0</p> <p>When read, returns the current value off the Compare Timer Output 0 state.</p> <p>If written with a '1b', the output state is cleared to '0'.</p> <p>Writes have no effect if COMPARE_SET1 in this register is written with a '1b' at the same time.</p> <p>Writes of '0b' have no effect.</p>	R/WC	0	RESET_SYS
24	<p>COMPARE_CLEAR1</p> <p>When read, returns the current value off the Compare Timer Output 1 state.</p> <p>If written with a '1b', the output state is cleared to '0'.</p> <p>Writes have no effect if COMPARE_SET0 in this register is written with a '1b' at the same time. Writes of '0b' have no effect.</p>	R/WC	0	RESET_SYS
23:18	Reserved	RES	-	-

MEC1725

Offset	00h			
Bits	Description	Type	Default	Reset Event
17	COMPARE_SET0 When read, returns the current value off the Compare Timer Output 0 state. <ul style="list-style-type: none"> • If written with a '1b', the output state is set to '1'. • Writes of '0b' have no effect 	R/WS	0	RESET_SYS
16	COMPARE_SET1 When read, returns the current value off the Compare Timer Output 1 state. If written with a '1b', the output state is set to '1'. Writes of '0b' have no effect	R/WS	0	RESET_SYS
15:10	Reserved	RES	-	-
9	COMPARE_ENABLE1 Compare Enable for Compare 1 Register. When enabled, a match between the Compare 1 Register and the Free Running Timer Register will cause the TOUT1 output to toggle and will send a COMPARE event to the Interrupt Aggregator. 1=Enabled 0=Disabled	R/W	0b	RESET_SYS
8	COMPARE_ENABLE0 Compare Enable for Compare 0 Register. When enabled, a match between the Compare 0 Register and the Free Running Timer Register will cause the TOUT0 output to toggle and will send a COMPARE event to the Interrupt Aggregator. 1=Enabled 0=Disabled	R/W	0b	RESET_SYS
7	Reserved	RES	-	-
6:4	TCLK This 3-bit field sets the clock source for the Free-Running Counter. See Table 22-2, "Timer Clock Frequencies" for a list of available frequencies.	R/W	0b	RESET_SYS
3	Reserved	RES	-	-
2	FREE_RESET Free Running Timer Reset. This bit stops the timer and resets the internal counter to 0000_0000h. This bit does not affect the FREE_ENABLE bit. This bit is self clearing after the timer is reset. 1=Timer reset 0=Normal timer operation	R/W	0h	RESET_SYS

Offset	00h			
Bits	Description	Type	Default	Reset Event
1	<p>FREE_ENABLE Free-Running Timer Enable. This bit is used to start and stop the free running timer. This bit does not reset the timer count. The timer starts counting at 0000_0000h on reset and wraps around back to 0000_0000h after it reaches FFFF_FFFFh.</p> <p>The FREE_ENABLE bit is cleared after the RESET cycle is done. Firmware must poll the FREE_RESET bit to determine when it is safe to re-enable the timer.</p> <p>1=Timer is enabled. The Free Running Timer Register is read-only. 0=Timer is disabled. The Free Running Timer Register is writable.</p>	R/W	0h	RESET_SYS
0	<p>ACTIVATE</p> <p>1=The timer block is in a running state 0=The timer block is powered down and all clocks are gated</p>	R/W	0h	RESET_SYS

22.10.2 CAPTURE CONTROL 0 REGISTER

Offset	04h			
Bits	Description	Type	Default	Reset Event
31:29	<p>FCLK_SEL3 This 3-bit field sets the clock source for the input filter for Capture Register 3. See Table 22-2, "Timer Clock Frequencies" for a list of available frequencies.</p>	R/W	0h	RESET_SYS
28:27	Reserved	RES	-	-
26	<p>FILTER_BYP3 This bit enables bypassing the input noise filter for Capture Register 3, so that the input signal goes directly into the timer.</p> <p>1=Input filter bypassed 0=Input filter enabled</p>	R/W	0h	RESET_SYS
25:24	<p>CAPTURE_EDGE3 This field selects the edge type that triggers the capture of the Free Running Counter into Capture Register 3.</p> <p>3=Capture event disabled 2=Both rising and falling edges 1=Rising edges 0=Falling edges</p>	R/W	0h	RESET_SYS
23:21	<p>FCLK_SEL2 This 3-bit field sets the clock source for the input filter for Capture Register 2. See Table 22-2, "Timer Clock Frequencies" for a list of available frequencies.</p>	R/W	0h	RESET_SYS

MEC1725

Offset	04h			
Bits	Description	Type	Default	Reset Event
20:19	Reserved	RES	-	-
18	<p>FILTER_BYP2</p> <p>This bit enables bypassing the input noise filter for Capture Register 2, so that the input signal goes directly into the timer.</p> <p>1=Input filter bypassed 0=Input filter enabled</p>	R/W	0h	RESET_SYS
17:16	<p>CAPTURE_EDGE2</p> <p>This field selects the edge type that triggers the capture of the Free Running Counter into Capture Register 2.</p> <p>3=Capture event disabled 2=Both rising and falling edges 1=Rising edges 0=Falling edges</p>	R/W	0h	RESET_SYS
15:13	<p>FCLK_SEL1</p> <p>This 3-bit field sets the clock source for the input filter for Capture Register 1. See Table 22-2, "Timer Clock Frequencies" for a list of available frequencies.</p>	R/W	0b	RESET_SYS
12:11	Reserved	RES	-	-
10	<p>FILTER_BYP1</p> <p>This bit enables bypassing the input noise filter for Capture Register 1, so that the input signal goes directly into the timer.</p> <p>1=Input filter bypassed 0=Input filter enabled</p>	R/W	0h	RESET_SYS
9:8	<p>CAPTURE_EDGE1</p> <p>This field selects the edge type that triggers the capture of the Free Running Counter into Capture Register 1.</p> <p>3=Capture event disabled 2=Both rising and falling edges 1=Rising edges 0=Falling edges</p>	R/W	0h	RESET_SYS
7:5	<p>FCLK_SEL0</p> <p>This 3-bit field sets the clock source for the input filter for Capture Register 0. See Table 22-2, "Timer Clock Frequencies" for a list of available frequencies.</p>	R/W	0h	RESET_SYS
4:3	Reserved	RES	-	-

Offset	04h			
Bits	Description	Type	Default	Reset Event
2	FILTER_BYP0 This bit enables bypassing the input noise filter for Capture Register 0, so that the input signal goes directly into the timer. 1=Input filter bypassed 0=Input filter enabled	R/W	0h	RESET_SYS
1:0	CAPTURE_EDGE0 This field selects the edge type that triggers the capture of the Free Running Counter into Capture Register 0. 3=Capture event disabled 2=Both rising and falling edges 1=Rising edges 0=Falling edges	R/W	0h	RESET_SYS

22.10.3 CAPTURE CONTROL 1 REGISTER

Offset	08h			
Bits	Description	Type	Default	Reset Event
31:16	Reserved	RES	-	-
15:13	FCLK_SEL5 This 3-bit field sets the clock source for the input filter for Capture Register 5. See Table 22-2, "Timer Clock Frequencies" for a list of available frequencies.	R/W	0b	RESET_SYS
12:11	Reserved	RES	-	-
10	FILTER_BYP5 This bit enables bypassing the input noise filter for Capture Register 5, so that the input signal goes directly into the timer. 1=Input filter bypassed 0=Input filter enabled	R/W	0h	RESET_SYS
9:8	CAPTURE_EDGE5 This field selects the edge type that triggers the capture of the Free Running Counter into Capture Register 5. 3=Capture event disabled 2=Both rising and falling edges 1=Rising edges 0=Falling edges	R/W	0h	RESET_SYS
7:5	FCLK_SEL4 This 3-bit field sets the clock source for the input filter for Capture Register 4. See Table 22-2, "Timer Clock Frequencies" for a list of available frequencies.	R/W	0h	RESET_SYS

MEC1725

Offset	08h			
Bits	Description	Type	Default	Reset Event
4:3	Reserved	RES	-	-
2	FILTER_BYP4 This bit enables bypassing the input noise filter for Capture Register 4, so that the input signal goes directly into the timer. 1=Input filter bypassed 0=Input filter enabled	R/W	0h	RESET_SYS
1:0	CAPTURE_EDGE4 This field selects the edge type that triggers the capture of the Free Running Counter into Capture Register 4. 3=Capture event disabled 2=Both rising and falling edges 1=Rising edges 0=Falling edges	R/W	0h	RESET_SYS

22.10.4 FREE RUNNING TIMER REGISTER

Offset	0Ch			
Bits	Description	Type	Default	Reset Event
31:0	FREE_RUNNING_TIMER This register contains the current value of the Free Running Timer. A Capture Timer interrupt is signaled to the Interrupt Aggregator when this register transitions from FFFF_FFFFh to 0000_0000h. When FREE_ENABLE in the Capture and Compare Timer Control Register is '1', this register is read-only. When FREE_ENABLE is '0', this register may be written.	R/W	0h	RESET_SYS

22.10.5 CAPTURE 0 REGISTER

Offset	10h			
Bits	Description	Type	Default	Reset Event
31:0	CAPTURE_0 This register saves the value copied from the Free Running timer on a programmed edge of ICT0.	R	0h	RESET_SYS

22.10.6 CAPTURE 1 REGISTER

Offset	14h			
Bits	Description	Type	Default	Reset Event
31:0	CAPTURE_1 This register saves the value copied from the Free Running timer on a programmed edge of ICT1. Note 1	R	0h	RESET_SYS
Note 1: Any ICT input can be routed to any capture register using the ICT mux select register				

22.10.7 CAPTURE 2 REGISTER

Offset	18h			
Bits	Description	Type	Default	Reset Event
31:0	CAPTURE_2 This register saves the value copied from the Free Running timer on a programmed edge of ICT2. Note 1	R	0h	RESET_SYS

22.10.8 CAPTURE 3 REGISTER

Offset	1Ch			
Bits	Description	Type	Default	Reset Event
31:0	CAPTURE_3 This register saves the value copied from the Free Running timer on a programmed edge of ICT3. Note 1	R	0h	RESET_SYS

22.10.9 CAPTURE 4 REGISTER

Offset	20h			
Bits	Description	Type	Default	Reset Event
31:0	CAPTURE_4 This register saves the value copied from the Free Running timer on a programmed edge of ICT4. Note 1	R	0h	RESET_SYS

MEC1725

22.10.10 CAPTURE 5 REGISTER

Offset	24h			
Bits	Description	Type	Default	Reset Event
31:0	CAPTURE_5 This register saves the value copied from the Free Running timer on a programmed edge of ICT5. Note 1	R	0h	RESET_SYS

22.10.11 COMPARE 0 REGISTER

Offset	28h			
Bits	Description	Type	Default	Reset Event
31:0	COMPARE_0 A COMPARE 0 interrupt is generated when this register matches the value in the Free Running Timer.	R/W	0h	RESET_SYS

22.10.12 COMPARE 1 REGISTER

Offset	2Ch			
Bits	Description	Type	Default	Reset Event
31:0	COMPARE_1 A COMPARE 1 interrupt is generated when this register matches the value in the Free Running Timer.	R/W	0h	RESET_SYS

22.10.13 ICT MUX SELECT REGISTER

This register selects the pin mapping to the capture register.

Offset	30h			
Bits	Description	Type	Default	Reset Event
31:24	Reserved	RES	-	-
23:20	Mux Select for Capture 5 register.	R/W	5h	RESET_SYS
19:16	Mux Select for Capture 4 register.	R/W	4h	RESET_SYS
15:12	Mux Select for Capture 3 register.	R/W	3h	RESET_SYS

Offset	30h			
Bits	Description	Type	Default	Reset Event
11:8	Mux Select for Capture 2 register.	R/W	2h	RESET_SYS
7:4	Mux Select for Capture 1 register.	R/W	1h	RESET_SYS
3:0	Mux Select for Capture 0 register.	R/W	0h	RESET_SYS

23.0 HIBERNATION TIMER

23.1 Introduction

The Hibernation Timer can generate a wake event to the Embedded Controller (EC) when it is in a hibernation mode. This block supports wake events up to 2 hours in duration. The timer is a 16-bit binary count-down timer that can be programmed in 30.5 μ s and 0.125 second increments for period ranges of 30.5 μ s to 2s or 0.125s to 136.5 minutes, respectively. Writing a non-zero value to this register starts the counter from that value. A wake-up interrupt is generated when the count reaches zero.

23.2 References

No references have been cited for this chapter

23.3 Terminology

No terms have been cited for this chapter.

23.4 Interface

This block is designed to be accessed internally via a registered host interface.

FIGURE 23-1: HIBERNATION TIMER INTERFACE DIAGRAM

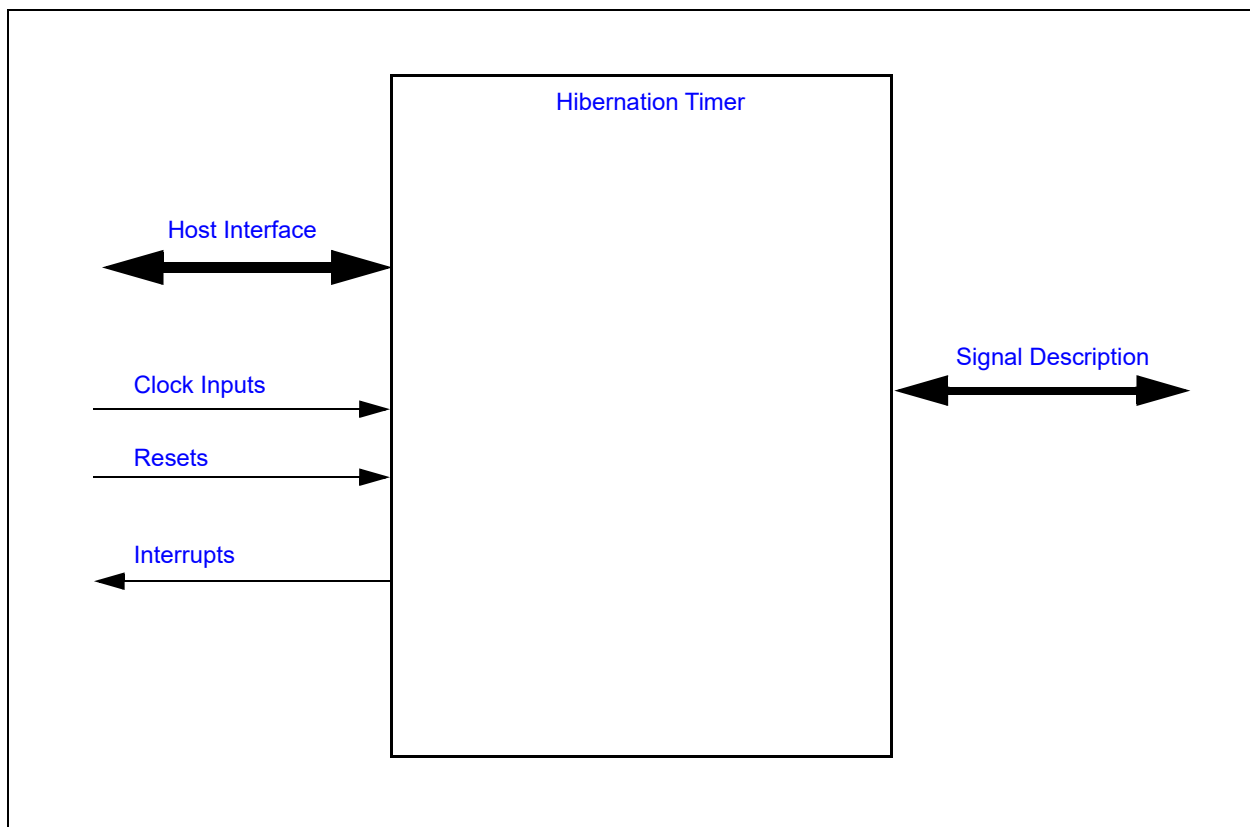

23.5 Signal Description

There are no external signals for this block.

23.6 Host Interface

The registers defined for the [Hibernation Timer](#) are accessible by the various hosts as indicated in [Section 3.2, "Block Overview and Base Addresses"](#).

23.7 Power, Clocks and Reset

This section defines the Power, Clock, and Reset parameters of the block.

23.7.1 POWER DOMAINS

TABLE 23-1: POWER SOURCES

Name	Description
VTR_CORE	The timer control logic and registers are all implemented on this single power domain.

23.7.2 CLOCK INPUTS

TABLE 23-2: CLOCK INPUTS

Name	Description
32KHz Core	This is the clock source to the timer logic. The Pre-scaler may be used to adjust the minimum resolution per bit of the counter. if the main oscillator is stopped then an external 32.768kHz clock source must be active for the Hibernation Timer to continue to operate.

23.7.3 RESETS

TABLE 23-3: RESET SIGNALS

Name	Description
RESET_SYS	This reset signal, which is an input to this block, resets all the logic and registers to their initial default state.

23.8 Interrupts

This section defines the interrupt Interface signals routed to the chip interrupt aggregator.

Each instance of the [Hibernation Timer](#) in the MEC1725 can be used to generate interrupts and wake-up events when the timer decrements to zero.

TABLE 23-4: INTERRUPT INTERFACE SIGNAL DESCRIPTION TABLE

Name	Direction	Description
HTIMER	Output	Signal indicating that the timer is enabled and decrements to 0. This signal is used to generate an Hibernation Timer interrupt event.

23.9 Low Power Modes

The timer operates off of the [32KHz Core](#) clock, and therefore will operate normally when the main oscillator is stopped.

The sleep enable inputs have no effect on the Hibernation Timer and the clock required outputs are only asserted during register read/write cycles for as long as necessary to propagate updates to the block core.

23.10 EC Registers

Registers for this block are shown in the following summary table. Addresses for each register are determined by adding the offset to the Base Address for each instance of the [Hibernation Timer](#) Block in the Block Overview and Base Address Table in [Section 3.0, "Device Inventory"](#).

TABLE 23-5: REGISTER SUMMARY

Offset	Register Name
00h	HTimer Preload Register
04h	HTimer Control Register
08h	HTimer Count Register

MEC1725

23.10.1 HTIMER PRELOAD REGISTER

Offset	00h			
Bits	Description	Type	Default	Reset Event
15:0	HT_PRELOAD This register is used to set the Hibernation Timer Preload value. Writing this register to a non-zero value resets the down counter to start counting down from this programmed value. Writing this register to 0000h disables the hibernation counter. The resolution of this timer is determined by the CTRL bit in the HTimer Control Register . Writes to the HTimer Control Register are completed with an EC bus cycle.	R/W	000h	RESET_SYS

23.10.2 HTIMER CONTROL REGISTER

Offset	04h			
Bits	Description	Type	Default	Reset Event
15:1	Reserved	RES	-	-
0	CTRL 1=The Hibernation Timer has a resolution of 0.125s per LSB, which yields a maximum time in excess of 2 hours. 0=The Hibernation Timer has a resolution of 30.5µs per LSB, which yields a maximum time of ~2seconds.	R	0000h	RESET_SYS

23.10.3 HTIMER COUNT REGISTER

Offset	08h			
Bits	Description	Type	Default	Reset Event
15:0	COUNT The current state of the Hibernation Timer.	R	0000h	RESET_SYS

24.0 RTOS TIMER

24.1 Introduction

The RTOS Timer is a low-power, 32-bit timer designed to operate on the 32kHz oscillator which is available during all chip sleep states. This allows firmware the option to sleep the processor and wake after a programmed amount of time. The timer may be used as a one-shot timer or a continuous timer. When the timer transitions to 0 it is capable of generating a wake-capable interrupt to the embedded controller. This timer may be halted during debug by hardware or via a software control bit.

24.2 Interface

This block is designed to be accessed internally via a registered host interface.

FIGURE 24-1: I/O DIAGRAM OF BLOCK

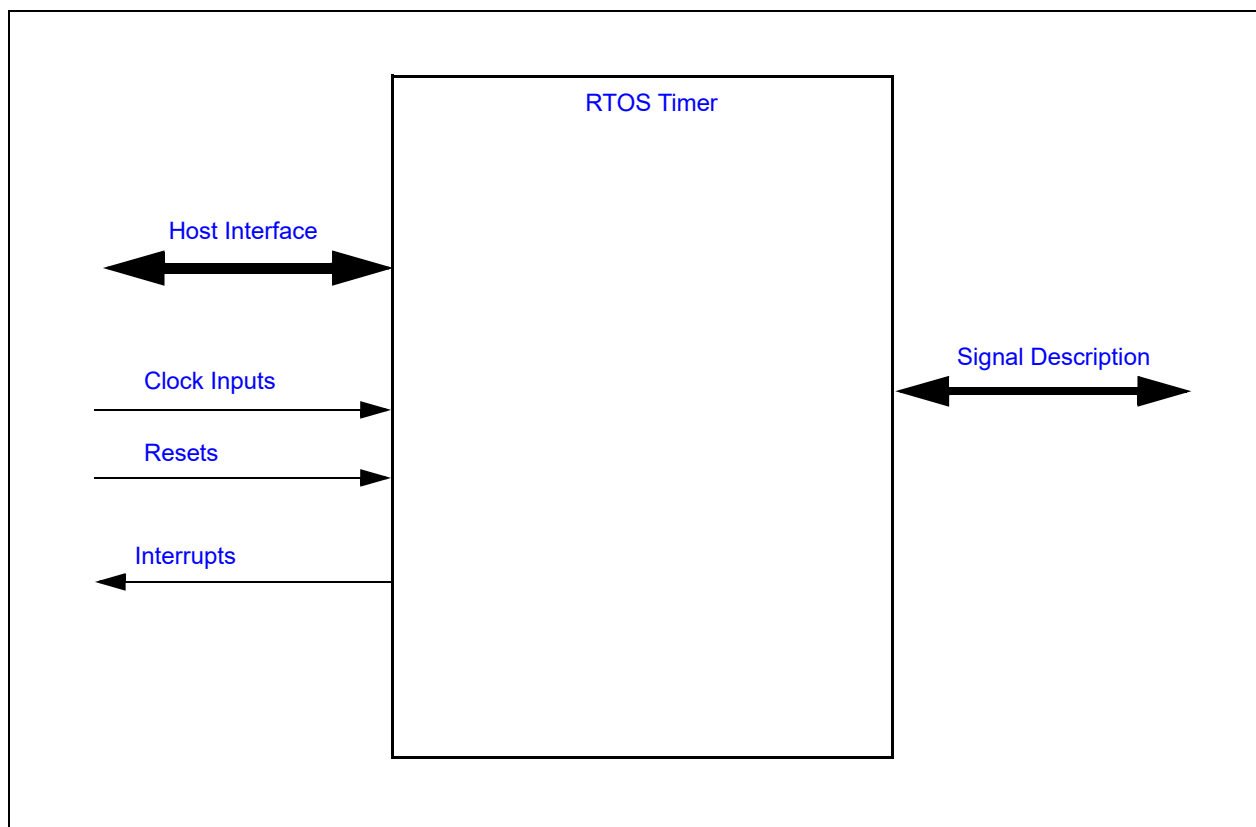

24.3 Signal Description

Name	Description
HALT	RTOS Timer Halt signal. This signal is connected to the same signal that halts the embedded controller during debug (e.g., JTAG Debugger is active, break points, etc.).

24.4 Host Interface

The Embedded Controller (EC) may access this block via the registers defined in [Section 24.9, "EC Registers"](#).

MEC1725

24.5 Power, Clocks and Reset

This section defines the Power, Clock, and Reset parameters of the block.

24.5.1 POWER DOMAINS

Name	Description
VTR_CORE	The timer control logic and registers are all implemented on this single power domain.

24.5.2 CLOCK INPUTS

Name	Description
32KHz Core	This is the clock source to the timer logic.

24.5.3 RESETS

Name	Description
RESET_SYS	This reset signal, which is an input to this block, resets all the logic and registers to their initial default state.

24.6 Interrupts

Source	Description
RTOS_TIMER	RTOS Timer interrupt event. The interrupt is signaled when the timer counter transitions from 1 to 0 while counting.

24.7 Low Power Modes

The Basic Timer may be put into a low power state by the chip's Power, Clocks, and Reset (PCR) circuitry. This block is only be permitted to enter low power modes when the block is not active.

24.8 Description

The RTOS Timer is a basic down counter that can operate either as a continuous timer or a one-shot timer. When it is started, the counter is loaded with a pre-load value and counts towards 0. When the counter counts down from 1 to 0, it will generate an interrupt. In one-shot mode (the [AUTO_RELOAD](#) bit is '0'), the timer will then halt; in continuous mode (the [AUTO_RELOAD](#) bit is '1'), the counter will automatically be restarted with the pre-load value.

The timer counter can be halted by firmware by setting the [FIRMWARE_TIMER_HALT](#) bit to '1'. In addition, if enabled, the timer counter can be halted by the external [HALT](#) signal.

24.9 EC Registers

Registers for this block are shown in the following summary table. Addresses for each register are determined by adding the offset to the Base Address for each instance of the [RTOS Timer](#) Block in the Block Overview and Base Address Table in [Section 3.0, "Device Inventory"](#).

TABLE 24-1: REGISTER SUMMARY

Offset	Register Name
00h	RTOS Timer Count Register
04h	RTOS Timer Preload Register
08h	RTOS Timer Control Register
0Ch	Soft Interrupt Register

24.9.1 RTOS TIMER COUNT REGISTER

Offset	00h			
Bits	Description	Type	Default	Reset Event
31:0	<p>COUNTER This register contains the current value of the RTOS Timer counter.</p> <p>This register should be read as a DWORD. There is no latching mechanism of the upper bytes implemented if the register is accessed as a byte or word. Reading the register with byte or word operations may give incorrect results.</p>	R/W	0h	RESET_SYS

24.9.2 RTOS TIMER PRELOAD REGISTER

Offset	04h			
Bits	Description	Type	Default	Reset Event
31:0	<p>PRE_LOAD The this register is loaded into the RTOS Timer counter either when the <code>TIMER_START</code> bit is written with a '1', or when the timer counter counts down to '0' and the <code>AUTO_RELOAD</code> bit is '1'.</p> <p>This register must be programmed with a new count value before the <code>TIMER_START</code> bit is set to '1'. If this register is updated while the counter is operating, the new count value will only take effect if the counter transitions from 1 to 0 while the <code>AUTO_RELOAD</code> bit is set.</p>	R/W	0h	RESET_SYS

MEC1725

24.9.3 RTOS TIMER CONTROL REGISTER

Offset	08h			
Bits	Description	Type	Default	Reset Event
31:5	Reserved	RES	-	-
4	FIRMWARE_TIMER_HALT 1=The timer counter is halted. If the counter was running, clearing this bit will restart the counter from the value at which it halted 0=The timer counter, if enabled, will continue to run	R/W	0h	RESET_SYS
3	EXT_HARDWARE_HALT_EN 1=The timer counter is halted when the external HALT signal is asserted. Counting is always enabled if HALT is de-asserted. 0=The HALT signal does not affect the RTOS Timer	R/W	0h	RESET_SYS
2	TIMER_START Writing a '1' to this bit will load the timer counter with the RTOS Timer Preload Register and start counting. If the Preload Register is 0, counting will not start and this bit will be cleared to '0'. Writing a '0' to this bit will halt the counter and clear its contents to 0. The RTOS timer interrupt will not be generated. This bit is automatically cleared if the AUTO_RELOAD bit is '0' and the timer counter transitions from 1 to 0.	R/W	0h	RESET_SYS
1	AUTO_RELOAD 1=The the RTOS Timer Preload Register is loaded into the timer counter and the counter is restarted when the counter transitions from 1 to 0 0=The timer counter halts when it transitions from 1 to 0 and will not restart	R/W	0h	RESET_SYS
0	BLOCK_ENABLE 1=RTOS timer counter is enabled 0=RTOS timer disabled. All register bits are reset to their default state	R/W	0h	RESET_SYS

24.9.4 SOFT INTERRUPT REGISTER

Offset	0Ch			
Bits	Description	Type	Default	Reset Event
31:4	Reserved	RES	-	-
3	SWI_3 Software Interrupt. A write of a '1' to this bit will generate an SWI interrupt to the EC. Writes of a '0' have no effect. Reads return '0'.	W	0h	RESE T_SYS
2	SWI_2 Software Interrupt. A write of a '1' to this bit will generate an SWI interrupt to the EC. Writes of a '0' have no effect. Reads return '0'.	W	0h	RESE T_SYS
1	SWI_1 Software Interrupt. A write of a '1' to this bit will generate an SWI interrupt to the EC. Writes of a '0' have no effect. Reads return '0'.	W	0h	RESE T_SYS
0	SWI_0 Software Interrupt. A write of a '1' to this bit will generate an SWI interrupt to the EC. Writes of a '0' have no effect. Reads return '0'.	W	0h	RESE T_SYS

25.0 REAL TIME CLOCK

25.1 Introduction

This block provides the capabilities of an industry-standard 146818B Real-Time Clock module, without CMOS RAM. Enhancements to this architecture include:

- Industry standard Day of Month Alarm field, allowing for monthly alarms
- Configurable, automatic Daylight Savings adjustment
- Week Alarm for periodic interrupts and wakes based on Day of Week
- System Wake capability on interrupts.

25.2 References

1. Motorola 146818B Data Sheet, available on-line
2. Intel Lynx Point PCH EDS specification

25.3 Terminology

Time and Date Registers:

This is the set of registers that are automatically counted by hardware every 1 second while the block is enabled to run and to update. These registers are: **Seconds, Minutes, Hours, Day of Week, Day of Month, Month, and Year.**

25.4 Interface

This block's connections are entirely internal to the chip.

FIGURE 25-1: I/O DIAGRAM OF BLOCK

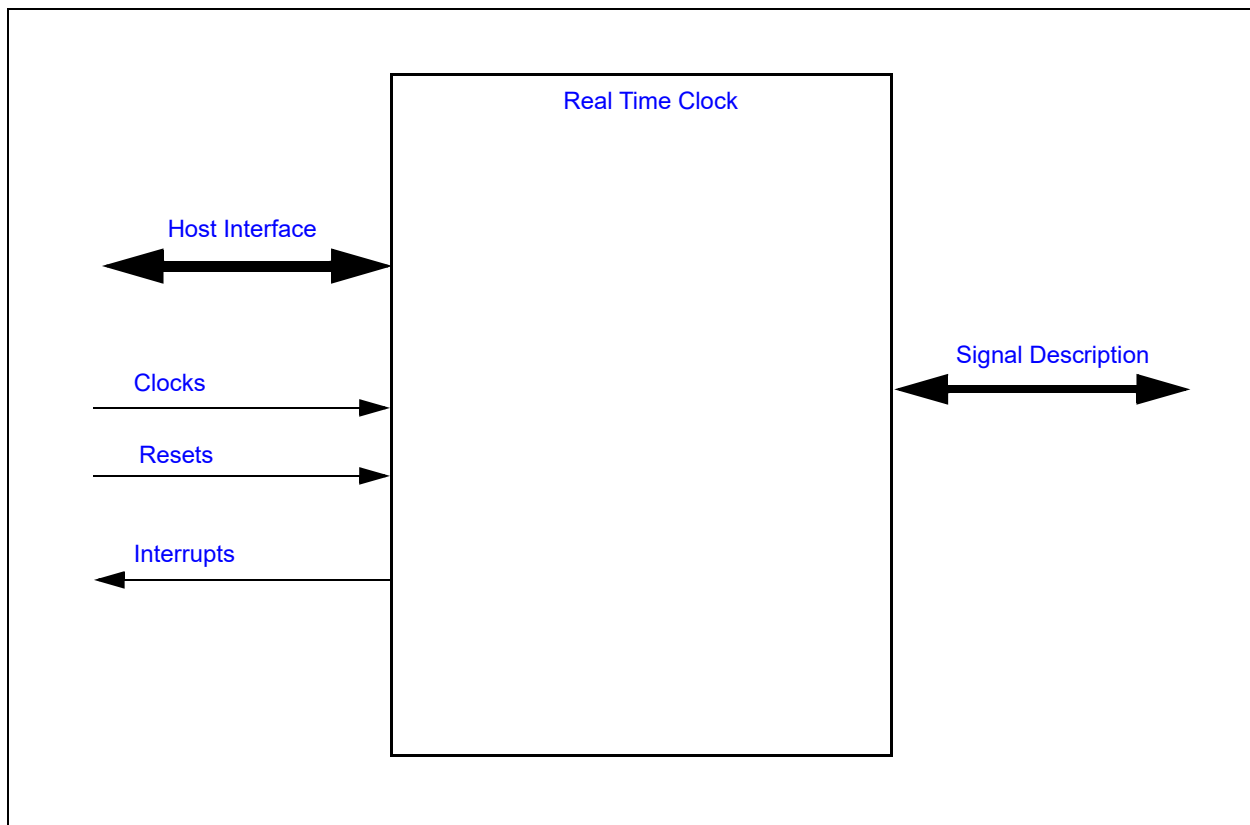

25.5 Signal Description

There are no external signals.

25.6 Host Interface

The registers defined for the [Real Time Clock](#) are accessible by the various hosts as indicated in [Section 3.2, "Block Overview and Base Addresses"](#).

25.7 Power, Clocks and Resets

This section defines the Power, Clock, and Reset parameters of the block.

25.7.1 POWER DOMAINS

TABLE 25-1: POWER SOURCES

Name	Description
VBAT	This power well sources all of the internal registers and logic in this block.
VTR_CORE	This power well sources only host register accesses. The block continues to operate internally while this rail is down.

25.7.2 CLOCKS

TABLE 25-2: CLOCKS

Name	Description
32KHz Core	This clock input drives all internal logic, and will be present at all times that the VBAT well is powered.

25.7.3 RESETS

TABLE 25-3: RESET SIGNALS

Name	Description
RESET_VBAT	This reset signal is used in the RESET_RTC signal to reset all of the registers and logic in this block. It directly resets the Soft Reset bit in the RTC Control Register.
RESET_RTC	This reset signal resets all of the registers and logic in this block, except for the Soft Reset bit in the RTC Control Register. It is triggered by RESET_VBAT , but can also be triggered by a SOFT_RESET from the RTC Control Register.
RESET_SYS	This reset signal is used to inhibit the bus communication logic, and isolates this block from VTR_CORE powered circuitry on-chip. Otherwise it has no effect on the internal state.
SOFT_RESET	This is the block reset and resets all the registers and logic in the block

25.8 Interrupts

TABLE 25-4: SYSTEM INTERRUPTS

Source	Description
RTC	This interrupt source for the SIRQ logic is generated when any of the following events occur: <ul style="list-style-type: none"> Update complete. This is triggered, at 1-second intervals, when the Time register updates have completed Alarm. This is triggered when the alarm value matches the current time (and date, if used) Periodic. This is triggered at the chosen programmable rate

TABLE 25-5: EC INTERRUPTS

Source	Description
RTC	This interrupt is signaled to the Interrupt Aggregator when any of the following events occur: <ul style="list-style-type: none"> • Update complete. This is triggered, at 1-second intervals, when the Time register updates have completed • Alarm. This is triggered when the alarm value matches the current time (and date, if used) • Periodic. This is triggered at the chosen programmable rate
RTC ALARM	This wake interrupt is signaled to the Interrupt Aggregator when an Alarm event occurs.

25.9 Low Power Modes

The RTC has no low-power modes. It runs continuously while the [VBAT](#) well is powered.

25.10 Description

This block provides the capabilities of an industry-standard 146818B Real-Time Clock module, excluding the CMOS RAM and the SQW output. See the following registers, which represent enhancements to this architecture. These enhancements are listed below.

See the Date Alarm field of [Register D](#) for a Day of Month qualifier for alarms.

See the [Week Alarm Register](#) for a Day of Week qualifier for alarms.

See the registers [Daylight Savings Forward Register](#) and [Daylight Savings Backward Register](#) for setting up hands-off Daylight Savings adjustments.

See the [RTC Control Register](#) for enhanced control over the block's operations.

25.11 Runtime Registers

The registers listed in the Runtime Register Summary table are for a single instance of the [Real Time Clock](#). Host access for each register listed in this table is defined as an offset in the Host address space to the Block's Base Address, as defined by the instance's Base Address Register.

The EC address for each register is formed by adding the Base Address for each instance of the [Real Time Clock](#) shown in the Block Overview and Base Address Table in [Section 3.0, "Device Inventory"](#) to the offset shown in the "Offset" column.

TABLE 25-6: RUNTIME REGISTER SUMMARY

Offset	Register Name
00h	Seconds Register
01h	Seconds Alarm Register
02h	Minutes Register
03h	Minutes Alarm Register
04h	Hours Register
05h	Hours Alarm Register
06h	Day of Week Register
07h	Day of Month Register
08h	Month Register
09h	Year Register
0Ah	Register A
0Bh	Register B

TABLE 25-6: RUNTIME REGISTER SUMMARY (CONTINUED)

Offset	Register Name
0Ch	Register C
0Dh	Register D
0Eh	Reserved
0Fh	Reserved
10h	RTC Control Register
14h	Week Alarm Register
18h	Daylight Savings Forward Register
1Ch	Daylight Savings Backward Register
20h	TEST

Note: This extended register set occupies offsets that have historically been used as CMOS RAM. Code ported to use this block should be examined to ensure that it does not assume that RAM exists in this block.

25.11.1 SECONDS REGISTER

Offset	00h			
Bits	Description	Type	Default	Reset Event
7:0	SECONDS Displays the number of seconds past the current minute, in the range 0--59. Presentation may be selected as binary or BCD, depending on the DM bit in Register B. Values written must also use the format defined by the current setting of the DM bit.	R/W	00h	RESET_RTC

25.11.2 SECONDS ALARM REGISTER

Offset	01h			
Bits	Description	Type	Default	Reset Event
7:0	SECONDS_ALARM Holds a match value, compared against the Seconds Register to trigger the Alarm event. Values written to this register must use the format defined by the current setting of the DM bit in Register B. A value of 11xxxxxb written to this register makes it don't-care (always matching).	R/W	00h	RESET_RTC

25.11.3 MINUTES REGISTER

Offset	02h			
Bits	Description	Type	Default	Reset Event
7:0	MINUTES Displays the number of minutes past the current hour, in the range 0--59. Presentation may be selected as binary or BCD, depending on the DM bit in Register B. Values written must also use the format defined by the current setting of the DM bit.	R/W	00h	RESET_RTC

MEC1725

25.11.4 MINUTES ALARM REGISTER

Offset	03h			
Bits	Description	Type	Default	Reset Event
7:0	MINUTES_ALARM Holds a match value, compared against the Minutes Register to trigger the Alarm event. Values written to this register must use the format defined by the current setting of the DM bit in Register B. A value of 11xxxxxb written to this register makes it don't-care (always matching).	R/W	00h	RESET_RTC

25.11.5 HOURS REGISTER

Offset	04h			
Bits	Description	Type	Default	Reset Event
7	HOURS_AM_PM In 12-hour mode (see bit "24/12" in register B), this bit indicates AM or PM. 1=PM 0=AM	R/W	0b	RESET_RTC
6:0	HOURS Displays the number of the hour, in the range 1--12 for 12-hour mode (see bit "24/12" in register B), or in the range 0--23 for 24-hour mode. Presentation may be selected as binary or BCD, depending on the DM bit in Register B. Values written must also use the format defined by the current setting of the DM bit.	R/W	00h	RESET_RTC

25.11.6 HOURS ALARM REGISTER

Offset	05h			
Bits	Description	Type	Default	Reset Event
7:0	HOURS_ALARM Holds a match value, compared against the Hours Register to trigger the Alarm event. Values written to this register must use the format defined by the current settings of the DM bit and the 24/12 bit in Register B. A value of 11xxxxxb written to this register makes it don't-care (always matching).	R/W	00h	RESET_RTC

25.11.7 DAY OF WEEK REGISTER

Offset	06h			
Bits	Description	Type	Default	Reset Event
7:0	DAY_OF_WEEK Displays the day of the week, in the range 1 (Sunday) through 7 (Saturday). Numbers in this range are identical in both binary and BCD notation, so this register's format is unaffected by the DM bit.	R/W	00h	RESET_RTC

25.11.8 DAY OF MONTH REGISTER

Offset	07h			
Bits	Description	Type	Default	Reset Event
7:0	DAY_OF_MONTH Displays the day of the current month, in the range 1--31. Presentation may be selected as binary or BCD, depending on the DM bit in Register B. Values written must also use the format defined by the current setting of the DM bit.	R/W	00h	RESET_RTC

25.11.9 MONTH REGISTER

Offset	08h			
Bits	Description	Type	Default	Reset Event
7:0	MONTH Displays the month, in the range 1--12. Presentation may be selected as binary or BCD, depending on the DM bit in Register B. Values written must also use the format defined by the current setting of the DM bit.	R/W	00h	RESET_RTC

25.11.10 YEAR REGISTER

Offset	09h			
Bits	Description	Type	Default	Reset Event
7:0	YEAR Displays the number of the year in the current century, in the range 0 (year 2000) through 99 (year 2099). Presentation may be selected as binary or BCD, depending on the DM bit in Register B. Values written must also use the format defined by the current setting of the DM bit.	R/W	00h	RESET_RTC

MEC1725

25.11.11 REGISTER A

Offset	0Ah			
Bits	Description	Type	Default	Reset Event
7	UPDATE_IN_PROGRESS '0' indicates that the Time and Date registers are stable and will not be altered by hardware soon. '1' indicates that a hardware update of the Time and Date registers may be in progress, and those registers should not be accessed by the host program. This bit is set to '1' at a point 488us (16 cycles of the 32K clock) before the update occurs, and is cleared immediately after the update. See also the Update-Ended Interrupt, which provides more useful status.	R	0b	RESET_RTC
6:4	DIVISION_CHAIN_SELECT This field provides general control for the Time and Date register updating logic. 11xb=Halt counting. The next time that 010b is written, updates will begin 500ms later. 010b=Required setting for normal operation. It is also necessary to set the Block Enable bit in the RTC Control Register to '1' for counting to begin 000b=Reserved. This field should be initialized to another value before Enabling the block in the RTC Control Register Other values Reserved	R/W	000b	RESET_RTC
3:0	RATE_SELECT This field selects the rate of the Periodic Interrupt source. See Table 25-7	R/W	0h	RESET_RTC

TABLE 25-7: REGISTER A FIELD RS: PERIODIC INTERRUPT SETTINGS

RS (hex)	Interrupt Period
0	Never Triggered
1	3.90625 ms
2	7.8125 ms
3	122.070 us
4	244.141 us
5	488.281 us
6	976.5625 us
7	1.953125 ms
8	3.90625 ms
9	7.8125 ms
A	15.625 ms
B	31.25 ms
C	62.5 ms
D	125 ms
E	250 ms
F	500 ms

25.11.12 REGISTER B

Offset	0Bh			
Bits	Description	Type	Default	Reset Event
7	UPDATE_CYCLE_INHIBIT In its default state '0', this bit allows hardware updates to the Time and Date registers, which occur at 1-second intervals. A '1' written to this field inhibits updates, allowing these registers to be cleanly written to different values. Writing '0' to this bit allows updates to continue.	R/W	0b	RESET_RTC
6	PERIODIC_INTERRUPT_ENABLE 1=Allows the Periodic Interrupt events to be propagated as interrupts 0=Periodic events are not propagated as interrupts	R/W	0b	RESET_RTC
5	ALARM_INTERRUPT_ENABLE 1=Allows the Alarm Interrupt events to be propagated as interrupts 0=Alarm events are not propagated as interrupts	R/W	0b	RESET_RTC
4	UPDATE_ENDED_INTERRUPT_ENABLE 1=Allows the Update Ended Interrupt events to be propagated as interrupts 0=Update Ended events are not propagated as interrupts	R/W	0b	RESET_RTC
3	Reserved	RES	-	-
2	DATA_MODE 1=Binary Mode for Dates and Times 0=BCD Mode for Dates and Times	R/W	0b	RESET_RTC
1	HOUR_FORMAT_24_12 1=24-Hour Format for Hours and Hours Alarm registers. 24-Hour format keeps the AM/PM bit off, with value range 0--23 0=12-Hour Format for Hours and Hours Alarm registers. 12-Hour format has an AM/PM bit, and value range 1--12	R/W	0b	RESET_RTC
0	DAYLIGHT_SAVINGS_ENABLE 1=Enables automatic hardware updating of the hour, using the registers Daylight Savings Forward and Daylight Savings Backward to select the yearly date and hour for each update 0=Automatic Daylight Savings updates disabled	R/W	0b	RESET_RTC

Note: The DATA_MODE and HOUR_FORMAT_24_12 bits affect only how values are presented as they are being read and how they are interpreted as they are being written. They do not affect the internal contents or interpretations of registers that have already been written, nor do they affect how those registers are represented or counted internally. This mode bits may be set and cleared dynamically, for whatever I/O data representation is desired by the host program.

MEC1725

25.11.13 REGISTER C

Offset	0Ch			
Bits	Description	Type	Default	Reset Event
7	INTERRUPT_REQUEST_FLAG 1=Any of bits[6:4] below is active after masking by their respective Enable bits in Register B. 0=No bits in this register are active This bit is automatically cleared by every Read access to this register.	RC	0b	RESET_RTC
6	PERIODIC_INTERRUPT_FLAG 1=A Periodic Interrupt event has occurred since the last time this register was read. This bit displays status regardless of the Periodic Interrupt Enable bit in Register B 0=A Periodic Interrupt event has not occurred This bit is automatically cleared by every Read access to this register.	RC	0b	RESET_RTC
5	ALARM_FLAG 1=An Alarm event has occurred since the last time this register was read. This bit displays status regardless of the Alarm Interrupt Enable bit in Register B. 0=An Alarm event has not occurred This bit is automatically cleared by every Read access to this register.	RC	0b	RESET_RTC
4	UPDATE_ENDED_INTERRUPT_FLAG 1=A Time and Date update has completed since the last time this register was read. This bit displays status regardless of the Update-Ended Interrupt Enable bit in Register B. Presentation of this status indicates that the Time and Date registers will be valid and stable for over 999ms 0=A Time and Data update has not completed since the last time this register was read This bit is automatically cleared by every Read access to this register.	RC	0b	RESET_RTC
3:0	Reserved	RES	-	-

25.11.14 REGISTER D

Offset	0Dh			
Bits	Description	Type	Default	Reset Event
7:6	Reserved	RES	-	-
5:0	DATE_ALARM This field, if set to a non-zero value, will inhibit the Alarm interrupt unless this field matches the contents of the Month register also. If this field contains 00h (default), it represents a don't-care, allowing more frequent alarms.	R/W	00h	RESET_RTC

25.11.15 RTC CONTROL REGISTER

Offset	10h			
Bits	Description	Type	Default	Reset Event
7:4	Reserved	RES	-	-
3	ALARM_ENABLE 1=Enables the Alarm features 0=Disables the Alarm features	R/W	0b	RESET_RTC
2	VCI_ENABLE 1= RTC Alarm event is routed to chip level VCI circuitry 0= RTC Alarm event is inhibited from affecting the VCI Circuitry	R/W	0b	RESET_RTC
1	SOFT_RESET A '1' written to this bit position will trigger the RESET_RTC reset, resetting the block and all registers except this one and the Test Register. This bit is self-clearing at the end of the reset.	R/W	0b	RESET_VBAT
0	BLOCK_ENABLE This bit must be '1' in order for the block to function internally. Registers may be initialized first, before setting this bit to '1' to start operation.	R/W	0b	RESET_RTC

25.11.16 WEEK ALARM REGISTER

Offset	14h			
Bits	Description	Type	Default	Reset Event
7:0	ALARM_DAY_OF_WEEK This register, if written to a value in the range 1--7, will inhibit the Alarm interrupt unless this field matches the contents of the Day of Week Register also. If this field is written to any value 11xxxxxb (like the default FFh), it represents a don't-care, allowing more frequent alarms, and will read back as FFh until another value is written.	R/W	FFh	RESET_RTC

25.11.17 DAYLIGHT SAVINGS FORWARD REGISTER

Offset	18h			
Bits	Description	Type	Default	Reset Event
31	DST_FORWARD_AM_PM This bit selects AM vs. PM, to match bit[7] of the Hours Register if 12-Hour mode is selected in Register B at the time of writing.	R/W	0b	RESET_RTC
30:24	DST_FORWARD_HOUR This field holds the matching value for bits[6:0] of the Hours register. The written value will be interpreted according to the 24/12 Hour mode and DM mode settings at the time of writing.	R/W	00h	RESET_RTC
23:19	Reserved	RES	-	-

MEC1725

Offset	18h			
Bits	Description	Type	Default	Reset Event
18:16	DST_FORWARD_WEEK This value matches an internally-maintained week number within the current month. Valid values for this field are: 5=Last week of month 4 =Fourth week of month 3=Third week of month 2=Second week of month 1=First week of month	R/W	0h	RESET_RTC
15:11	Reserved	RES	-	-
10:8	DST_FORWARD_DAY_OF_WEEK This field matches the Day of Week Register bits[2:0].	R/W	0h	RESET_RTC
7:0	DST_FORWARD_MONTH This field matches the Month Register.	R/W	00h	RESET_RTC

This is a 32-bit register, accessible also as individual bytes. When writing as individual bytes, ensure that the DSE bit (in Register B) is off first, or that the block is disabled or stopped (SET bit), to prevent a time update while this register may have incompletely-updated contents.

When enabled by the DSE bit in Register B, this register defines an hour and day of the year at which the Hours register will be automatically incremented by 1 additional hour.

There are no don't-care fields recognized. All fields must be already initialized to valid settings whenever the DSE bit is '1'.

Fields other than Week and Day of Week use the current setting of the DM bit (binary vs. BCD) to interpret the information as it is written to them. Their values, as held internally, are not changed by later changes to the DM bit, without subsequently writing to this register as well.

Note: An Alarm that is set inside the hour after the time specified in this register will not be triggered, because that one-hour period is skipped. This period includes the exact time (0 minutes: 0 seconds) given by this register, through the 59 minutes: 59 seconds point afterward.

25.11.18 DAYLIGHT SAVINGS BACKWARD REGISTER

Offset	1Ch			
Bits	Description	Type	Default	Reset Event
31	DST_BACKWARD_AM_PM This bit selects AM vs. PM, to match bit[7] of the Hours register if 12-Hour mode is selected in Register B at the time of writing.	R/W	0b	RESET_RTC
30:24	DST_BACKWARD_HOUR This field holds the matching value for bits[6:0] of the Hours register. The written value will be interpreted according to the 24/12 Hour mode and DM mode settings at the time of writing.	R/W	00h	RESET_RTC
23:19	Reserved	RES	-	-

Offset	1Ch			
Bits	Description	Type	Default	Reset Event
18:16	DST_BACKWARD_WEEK This value matches an internally-maintained week number within the current month. Valid values for this field are: 5=Last week of month 4 =Fourth week of month 3=Third week of month 2=Second week of month 1=First week of month	R/W	0h	RESET_RTC
15:11	Reserved	RES	-	-
10:8	DST_BACKWARD_DAY_OF_WEEK This field matches the Day of Week Register bits[2:0].	R/W	0h	RESET_RTC
7:0	DST_BACKWARD_MONTH This field matches the Month Register.	R/W	00h	RESET_RTC

This is a 32-bit register, accessible also as individual bytes. When writing as individual bytes, ensure that the DSE bit (in Register B) is off first, or that the block is disabled or stopped (SET bit), to prevent a time update while this register may have incompletely-updated contents.

When enabled by the DSE bit in Register B, this register defines an hour and day of the year at which the Hours register increment will be inhibited from occurring. After triggering, this feature is automatically disabled for long enough to ensure that it will not retrigger the second time this Hours value appears, and then this feature is re-enabled automatically.

There are no don't-care fields recognized. All fields must be already initialized to valid settings whenever the DSE bit is '1'.

Fields other than Week and Day of Week use the current setting of the DM bit (binary vs. BCD) to interpret the information as it is written to them. Their values, as held internally, are not changed by later changes to the DM bit, without subsequently writing to this register as well.

Note: An Alarm that is set inside the hour before the time specified in this register will be triggered twice, because that one-hour period is repeated. This period will include the exact time (0 minutes: 0 seconds) given by this register, through the 59 minutes: 59 seconds point afterward.

MEC1725

26.0 WEEK TIMER

26.1 Introduction

The Week Alarm Interface provides two timekeeping functions: a Week Timer and a Sub-Week Timer. Both the Week Timer and the Sub-Week Timer assert the Power-Up Event Output which automatically powers-up the system from the G3 state. Features include:

- EC interrupts based on matching a counter value
- Repeating interrupts at 1 second and sub-1 second intervals
- System Wake capability on interrupts, including Wake from Heavy Sleep

26.2 Interface

This block's connections are entirely internal to the chip.

FIGURE 26-1: I/O DIAGRAM OF BLOCK

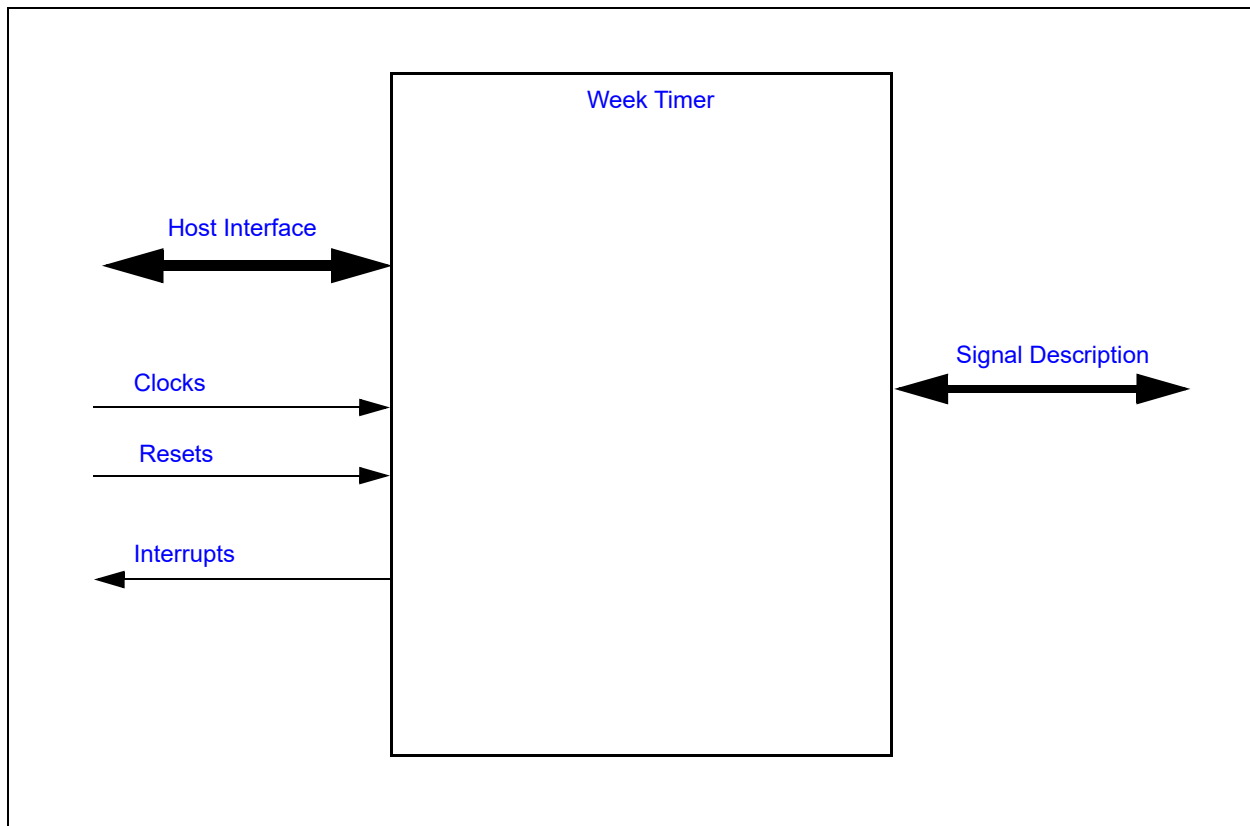

26.3 Signal Description

TABLE 26-1: SIGNAL DESCRIPTION TABLE

Name	Direction	Description
BGPO	OUTPUT	Battery-powered general purpose outputs
SYSPWR_PRE	INPUT	Input signal used to gate the POWER_UP_EVENT

Note 1: Please refer to [TABLE 1-1](#): for the number of BGPO's and SYSPWR_PRES availability in the package.

TABLE 26-2: INTERNAL SIGNAL DESCRIPTION TABLE

Name	Direction	Description
POWER_UP_EVENT	OUTPUT	Signal to the VBAT-Powered Control Interface. When this signal is asserted, the VCI output signal asserts. See Section 26.8, "Power-Up Events" .

26.4 Host Interface

The registers defined for the [Week Timer](#) are accessible only by the EC.

26.5 Power, Clocks and Resets

This section defines the Power, Clock, and Reset parameters of the block.

26.5.1 POWER DOMAINS

TABLE 26-3: POWER SOURCES

Name	Description
VBAT	This power well sources all of the internal registers and logic in this block.
VTR_CORE	This power well sources only host register accesses. The block continues to operate internally while this rail is down.

26.5.2 CLOCKS

TABLE 26-4: CLOCKS

Name	Description
96 MHz	Clock used for host register access
32KHz Core	This 32KHz clock input drives all internal logic, and will be present at all times that the VBAT well is powered.

26.5.3 RESETS

TABLE 26-5: RESET SIGNALS

Name	Description
RESET_VBAT	This reset signal is used reset all of the registers and logic in this block.
RESET_SYS	This reset signal is used to inhibit the Host register access and isolates this block from VTR_CORE powered circuitry on-chip. Otherwise it has no effect on the internal state.

26.6 Interrupts

TABLE 26-6: EC INTERRUPTS

Source	Description
WEEK_ALARM_INT	This interrupt is signaled to the Interrupt Aggregator when the Week Alarm Counter Register is greater than or equal to the Week Timer Compare Register . The interrupt signal is always generated by the Week Timer if the block is enabled; the interrupt is enabled or disabled in the Interrupt Aggregator.
SUB_WEEK_ALARM_INT	This interrupt is signaled to the Interrupt Aggregator when the Sub-Week Alarm Counter Register decrements from '1' to '0'. The interrupt signal is always generated by the Week Timer if the block is enabled; the interrupt is enabled or disabled in the Interrupt Aggregator.
ONE_SECOND	This interrupt is signaled to the Interrupt Aggregator at an isochronous rate of once per second. The interrupt signal is always generated by the Week Timer if the block is enabled; the interrupt is enabled or disabled in the Interrupt Aggregator.
SUB_SECOND	This interrupt is signaled to the Interrupt Aggregator at an isochronous rate programmable between 0.5Hz and 32.768KHz. The rate interrupts are signaled is determined by the SPISR field in the Sub-Second Programmable Interrupt Select Register . See Table 26-9, "SPISR Encoding" . The interrupt signal is always generated by the Week Timer if the block is enabled; the interrupt is enabled or disabled in the Interrupt Aggregator.

26.7 Low Power Modes

The Week Alarm has no low-power modes. It runs continuously while the [VBAT](#) well is powered.

26.8 Power-Up Events

The Week Timer [POWER_UP_EVENT](#) can be used to power up the system after a timed interval. The [POWER_UP_EVENT](#) is routed to the [VBAT-Powered Control Interface \(VCI\)](#). The [VCI_OUT](#) pin that is part of the VCI is asserted if the [POWER_UP_EVENT](#) is asserted.

The [POWER_UP_EVENT](#) can be asserted under the following two conditions:

1. The [Week Alarm Counter Register](#) is greater than or equal to the [Week Timer Compare Register](#)
2. The [Sub-Week Alarm Counter Register](#) decrements from '1' to '0'

The assertion of the [POWER_UP_EVENT](#) is inhibited if the [POWERUP_EN](#) field in the [Control Register](#) is '0'

Once a [POWER_UP_EVENT](#) is asserted the [POWERUP_EN](#) bit must be cleared to reset the output. Clearing [POWERUP_EN](#) is necessary to avoid unintended power-up cycles.

26.8.1 SYSPWR_PRESENCE PIN

The [SYSPWR_PRESENCE](#) input signal gates the [POWER_UP_EVENT](#). If the [SYSPWR_PRESENCE](#) gating function is enabled, the [POWER_UP_EVENT](#) is inhibited if the [SYSPWR_PRESENCE](#) input is low.

FIGURE 26-2: SYSPWR_PRES SELECT

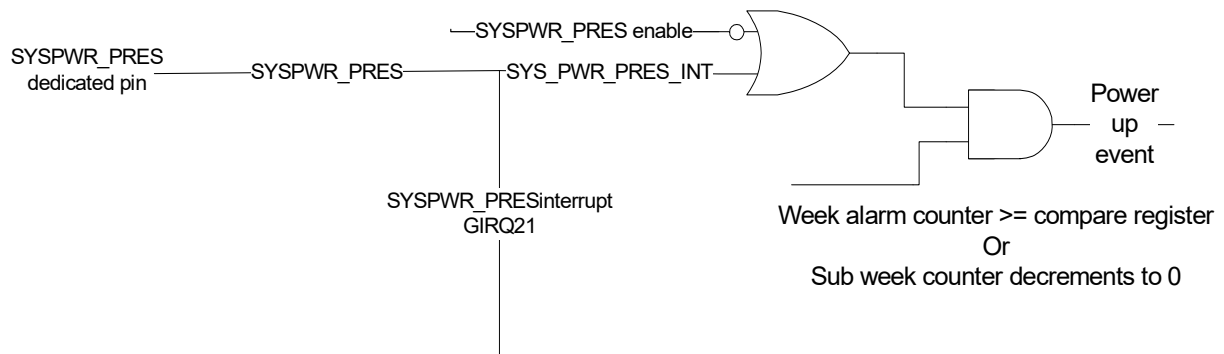

26.9 Description

The Week Alarm block provides battery-powered timekeeping functions, derived from a low-power 32KHz clock, that operate even when the device's main power is off. The block contains a set of counters that can be used to generate one-shot and periodic interrupts to the EC for periods ranging from about 30 microseconds to over 8 years. The Week Alarm can be used in conjunction with the VBAT-Powered Control Interface to power up a sleeping system after a configurable period.

In addition to basic timekeeping, the Week Alarm block can be used to control the battery-powered general purpose BGPO outputs.

26.9.1 INTERNAL COUNTERS

The Week Timer includes 3 counters:

26.9.1.1 28-bit Week Alarm Counter

This counter is 28 bits wide. The clock for this counter is the overflow of the Clock Divider, and as long as the Week Timer is enabled, it is incremented at a 1 Hz rate.

Both an interrupt and a power-up event can be generated when the contents of this counter matches the contents of the [Week Timer Compare Register](#).

26.9.1.2 9-bit Sub-Week Alarm Counter

This counter is 9 bits wide. It is decremented by 1 at each tick of its selected clock. It can be configured either as a one-shot or repeating event generator.

Both an interrupt and a power-up event can be generated when this counter decrements from 1 to 0.

The Sub-Week Alarm Counter can be configured with a number of different clock sources for its time base, derived from either the Week Alarm Counter or the Clock Divider, by setting the [SUBWEEK_TICK](#) field of the [Sub-Week Control Register](#).

MEC1725

TABLE 26-7: SUB-WEEK ALARM COUNTER CLOCK

SUBWEEK_TICK	Source	SPISR	Frequency	Minimum Duration	Maximum Duration
0	Counter Disabled				
1	Sub-Second	0	Counter Disabled		
		1	2 Hz	500 ms	255.5 sec
		2	4 Hz	250 ms	127.8 sec
		3	8 Hz	125 ms	63.9 sec
		4	16 Hz	62.5	31.9 sec
		5	32 Hz	31.25 ms	16.0 sec
		6	64 Hz	15.6 ms	8 sec
		7	128 Hz	7.8 ms	4 sec
		8	256 Hz	3.9 ms	2 sec
		9	512 Hz	1.95 ms	1 sec
		10	1024 Hz	977 μ S	499 ms
		11	2048 Hz	488 μ S	249.5 ms
		12	4096 Hz	244 μ S	124.8 ms
		13	8192 Hz	122 μ S	62.4 ms
		14	16.384 KHz	61.1 μ S	31.2 ms
15	32.768 KHz	30.5 μ S	15.6 ms		
2	Second	n/a	1 Hz	1 sec	511 sec
3	Reserved				
4	Week Counter bit 3	n/a	125 Hz	8 sec	68.1 min
5	Week Counter bit 5	n/a	31.25 Hz	32 sec	272.5 min
6	Week Counter bit 7	n/a	7.8125 Hz	128 sec	18.17 hour
7	Week Counter bit 9	n/a	1.95 Hz	512 sec	72.68 hour

Note 1: The Week Alarm Counter **must not** be modified by firmware if Sub-Week Alarm Counter is using the Week Alarm Counter as its clock source (i.e., the SUBWEEK_TICK field is set to any of the values 4, 5, 6 or 7). The Sub-Week Alarm Counter must be disabled before changing the Week Alarm Counter. For example, the following sequence may be used:

1. Write 0h to the [Sub-Week Alarm Counter Register](#) (disabling the Sub-Week Counter)
2. Write the [Week Alarm Counter Register](#)
3. Write a new value to the [Sub-Week Alarm Counter Register](#), restarting the Sub-Week Counter

26.9.1.3 15-bit Clock Divider

This counter is 15 bits wide. The clock for this counter is [32KHz Core](#), and as long as the Week Timer is enabled, it is incremented at 32.768KHz rate. The Clock Divider automatically generates a clock out of 1 Hz when the counter wraps from 7FFFh to 0h.

By selecting one of the 15 bits of the counter, using the [Sub-Second Programmable Interrupt Select Register](#), the Clock Divider can be used either to generate a time base for the Sub-Week Alarm Counter or as an isochronous interrupt to the EC, the SUB_SECOND interrupt. See [Table 26-9, "SPISR Encoding"](#) for a list of available frequencies.

26.9.2 TIMER VALID STATUS

If power on reset occurs on the **VBAT** power rail while the main device power is off, the counters in the Week Alarm are invalid. If firmware detects a POR on the **VBAT** power rail after a system boot, by checking the status bits in the Power, Clocks and Resets registers, the Week Alarm block must be reinitialized.

26.9.3 APPLICATION NOTE: REGISTER TIMING

Register writes in the Week Alarm complete within two cycles of the **32KHz Core** clock. The write completes even if the main system clock is stopped before the two cycles of the 32K clock complete. Register reads complete in one cycle of the internal bus clock.

All Week Alarm interrupts that are asserted within the same cycle of the **32KHz Core** clock are synchronously asserted to the EC.

26.9.4 APPLICATION NOTE: USE OF THE WEEK TIMER AS A 43-BIT COUNTER

The Week Timer cannot be directly used as a 42-bit counter that is incremented directly by the 32.768KHz clock domain. The upper 28 bits (**28-bit Week Alarm Counter**) are incremented at a 1Hz rate and the lower 16 bits (**15-bit Clock Divider**) are incremented at a 32.768KHz rate, but the increments are not performed in parallel. In particular, the upper 28 bits are incremented when the lower 15 bits increment from 0 to 1, so as long as the Clock Divider Register is 0 the two registers together, treated as a single value, have a smaller value than before the lower register rolled over from 7FFFh to 0h.

The following code can be used to treat the two registers as a single large counter. This example extracts a 32-bit value from the middle of the 43-bit counter:

```
dword TIME_STAMP(void)
{
    AHB_dword wct_value;
    AHB_dword cd_value1;
    AHB_dword cd_value2;
    dword irqEnableSave;

    //Disable interrupts
    irqEnableSave = IRQ_ENABLE;
    IRQ_ENABLE = 0;

    //Read 15-bit clk divider reading register, save result in A
    cd_value1 = WTIMER->CLOCK_DIVIDER;
    //Read 28 bit up-counter timer register, save result in B
    wct_value = WTIMER->WEEK_COUNTER_TIMER;
    //Read 15-bit clk divider reading register, save result in C
    cd_value2 = WTIMER->CLOCK_DIVIDER;

    if (0 == cd_value2)
    {
        wct_value = wct_value + 1;
    }
    else if ( (cd_value2 < cd_value1) || (0 == cd_value1))
    {
        wct_value = WTIMER->WEEK_COUNTER_TIMER;
    }

    //Enable interrupts
    IRQ_ENABLE = irqEnableSave;

    return (WTIMER_BASE + ((wct_value << 10) | (cd_value2>>5)));
}
```

26.9.5 APPLICATION NOTE: WEEK TIMER INITIALIZATION AND PROGRAMMING SEQUENCE

The week alarm timers may sometimes expire earlier than the configured time interval by an interval of up to one unit of the alarm time source. For instance the when you configure the timer for an interval of 5 seconds with a base time unit of 1 second it may expire at an interval between 4 and 5 seconds.

MEC1725

In case of repeating or auto-reload alarms the issue may be observed only on the first instance of the expiry after enable. No such deviation would be observed from the second expiry of the auto reload timer.

The issue can be avoided by introducing a 25uS delay before enabling the timer after writing to all other config registers of the timer. Any application which is sensitive/critical to the timer expiry is recommended to add a delay as suggested above before enabling the timer.

26.10 Battery-Powered General Purpose Outputs

The Week Timer contains the control logic for Battery-Powered General Purposes Outputs (BGPOs). These are output-only pins whose state can be controlled by firmware and preserved when the device is operating on **VBAT** power alone.

When a BGPO function is selected on a pin that can also serve as a GPIO, using the [BGPO Power Register](#), the GPIO input register is readable and reads the pin value.

26.11 EC Registers

Registers for this block are shown in the following summary table. Addresses for each register are determined by adding the offset to the Base Address for each instance of the [Week Timer](#) Block in the Block Overview and Base Address Table in [Section 3.0, "Device Inventory"](#).

TABLE 26-8: REGISTER SUMMARY

Offset	Register Name
00h	Control Register
04h	Week Alarm Counter Register
08h	Week Timer Compare Register
0Ch	Clock Divider Register
10h	Sub-Second Programmable Interrupt Select Register
14h	Sub-Week Control Register
18h	Sub-Week Alarm Counter Register
1Ch	BGPO Data Register
20h	BGPO Power Register
24h	BGPO Reset Register

26.11.1 CONTROL REGISTER

Offset	00h			
Bits	Description	Type	Default	Reset Event
31:7	Reserved	RES	-	-
6	<p>POWERUP_EN</p> <p>This bit controls the state of the Power-Up Event Output and enables Week POWER-UP Event decoding in the VBAT-Powered Control Interface. See Section 26.8, "Power-Up Events" for a functional description of the POWER-UP_EN bit.</p> <p>1=Power-Up Event Output Enabled 0=Power-Up Event Output Disabled and Reset</p>	R/W	00h	RESET_VBAT
5:1	Reserved	RES	-	-
0	<p>WT_ENABLE</p> <p>The WT_ENABLE bit is used to start and stop the Week Alarm Counter Register and the Clock Divider Register.</p> <p>The value in the Counter Register is held when the WT_ENABLE bit is not asserted ('0') and the count is resumed from the last value when the bit is asserted ('1').</p> <p>The 15-Bit Clock Divider is reset to 00h and the Week Alarm Interface is in its lowest power consumption state when the WT_ENABLE bit is not asserted.</p>	R/W	1h	RESET_VBAT

26.11.2 WEEK ALARM COUNTER REGISTER

Offset	04h			
Bits	Description	Type	Default	Reset Event
31:28	Reserved	RES	-	-
27:0	<p>WEEK_COUNTER</p> <p>While the WT_ENABLE bit is '1', this register is incremented at a 1 Hz rate. Writes of this register may require one second to take effect. Reads return the current state of the register. Reads and writes complete independently of the state of WT_ENABLE.</p>	R/W	00h	RESET_VBAT

MEC1725

26.11.3 WEEK TIMER COMPARE REGISTER

Offset	08h			
Bits	Description	Type	Default	Reset Event
31:28	Reserved	RES	-	-
27:0	WEEK_COMPARE A Week Alarm Interrupt and a Week Alarm Power-Up Event are asserted when the Week Alarm Counter Register is greater than or equal to the contents of this register. Reads and writes complete independently of the state of WT_ENABLE.	R/W	FFFFFFFh	RESET_VBAT

26.11.4 CLOCK DIVIDER REGISTER

Offset	0Ch			
Bits	Description	Type	Default	Reset Event
31:15	Reserved	RES	-	-
14:0	CLOCK_DIVIDER Reads of this register return the current state of the Week Timer 15-bit clock divider.	R	-	RESET_VBAT

26.11.5 SUB-SECOND PROGRAMMABLE INTERRUPT SELECT REGISTER

Offset	10h			
Bits	Description	Type	Default	Reset Event
31:4	Reserved	RES	-	-
3:0	SPIISR This field determines the rate at which Sub-Second interrupt events are generated. Table 26-9, "SPIISR Encoding" shows the relation between the SPIISR encoding and Sub-Second interrupt rate.	R/W	00h	RESET_VBAT

TABLE 26-9: SPIISR ENCODING

SPIISR Value	Sub-Second Interrupt Rate, Hz	Interrupt Period
0	Interrupts disabled	
1	2	500 ms
2	4	250 ms
3	8	125 ms
4	16	62.5 ms
5	32	31.25 ms
6	64	15.63 ms

TABLE 26-9: SPISR ENCODING (CONTINUED)

SPISR Value	Sub-Second Interrupt Rate, Hz	Interrupt Period
7	128	7.813 ms
8	256	3.906 ms
9	512	1.953 ms
10	1024	977 μ S
11	2048	488 μ S
12	4096	244 μ S
13	8192	122 μ S
14	16384	61 μ S
15	32768	30.5 μ S

26.11.6 SUB-WEEK CONTROL REGISTER

Offset	14h			
Bits	Description	Type	Default	Reset Event
31:10	Reserved	RES	-	-
9:7	SUBWEEK_TICK This field selects the clock source for the Sub-Week Counter. See Table 26-7, "Sub-Week Alarm Counter Clock" for the description of the options for this field. See also Note 1 .	R/W	0	RESET_VBAT
6	AUTO_RELOAD 1= No reload occurs when the Sub-Week Counter expires 0= Reloads the SUBWEEK_COUNTER_LOAD field into the Sub-Week Counter when the counter expires.	R/W	0	RESET_VBAT
5	SYSPWR_PRESENABLE This bit controls whether the SYSPWR_PRESENABLE input pin has an effect on the POWER_UP_EVENT signal from this block. 1=The POWER_UP_EVENT will only be asserted if the SYSPWR_PRESENABLE input is high. If the SYSPWR_PRESENABLE input is low, the POWER_UP_EVENT will not be asserted 0=The SYSPWR_PRESENABLE input is ignored. It has no effect on the POWER_UP_EVENT	R/W	0	RESET_VBAT
4	SYSPWR_PRESENABLE_STATUS This bit provides the current state of the SYSPWR_PRESENABLE input pin.	R	-	RESET_VBAT
5	TEST Must always be written with 0.	R/W	0	-
4:2	Reserved	RES	-	-

MEC1725

Offset	14h			
Bits	Description	Type	Default	Reset Event
1	<p>WEEK_TIMER_POWERUP_EVENT_STATUS</p> <p>This bit is set to '1' when the Week Alarm Counter Register is greater than or equal the contents of the Week Timer Compare Register and the POWERUP_EN is '1'.</p> <p>Writes of '1' clear this bit. Writes of '0' have no effect.</p> <p>Note: This bit <u>does not</u> have to be cleared to remove a Week Timer Power-Up Event.</p>	R/WC	0	RESET_VBAT
0	<p>SUBWEEK_TIMER_POWERUP_EVENT_STATUS</p> <p>This bit is set to '1' when the Sub-Week Alarm Counter Register decrements from '1' to '0' and the POWERUP_EN is '1'.</p> <p>Writes of '1' clear this bit. Writes of '0' have no effect.</p> <p>Note: This bit <u>MUST</u> be cleared to remove a Sub-Week Timer Power-Up Event.</p>	R/WC	0	RESET_VBAT

26.11.7 SUB-WEEK ALARM COUNTER REGISTER

Offset	18h			
Bits	Description	Type	Default	Reset Event
31:25	Reserved	RES	-	-
24:16	<p>SUBWEEK_COUNTER_STATUS</p> <p>Reads of this register return the current state of the 9-bit Sub-Week Alarm counter.</p>	R	00h	RESET_VBAT
15:9	Reserved	RES	-	-
8:0	<p>SUBWEEK_COUNTER_LOAD</p> <p>Writes with a non-zero value to this field reload the 9-bit Sub-Week Alarm counter. Writes of 0 disable the counter.</p> <p>If the Sub-Week Alarm counter decrements to 0 and the AUTO_RELOAD bit is set, the value in this field is automatically loaded into the Sub-Week Alarm counter.</p>	R/W	00h	RESET_VBAT

26.11.8 BGPO DATA REGISTER

Offset	1Ch			
Bits	Description	Type	Default	Reset Event
31:3	Reserved	RES	-	-
5:0	<p>BGPO Battery powered General Purpose Output. Each output pin may be individually configured to be either a VBAT-power BGPO or a VTR-powered GPIO, based on the corresponding settings in the BGPO Power Register. Additionally, each output pin may be individually configured to reset to 0 on either RESET_VBAT or RESET_SYS, based on the corresponding settings in the BGPO Reset Register.</p> <p>For each bit [i] in the field: 1=BGPO[i] output is high 0=BGPO[i] output is low</p> <p>If a BGPO[i] does not appear in a package, the corresponding bit must be written with a 0 or undesirable results will occur.</p>	R/W	0h	RESET_VBAT or RESET_SYS

26.11.9 BGPO POWER REGISTER

Offset	20h			
Bits	Description	Type	Default	Reset Event
31:6	Reserved	RES	-	-
5:1	<p>BGPO_POWER Battery powered General Purpose Output power source.</p> <p>For each bit [i] in the field: 1=BGPO[i] is powered by VBAT. The BGPO[i] pin is always determined by the corresponding bit in the BGPO Data Register. The GPIO Input register for the GPIO that is multiplexed with the BGPO always returns a '1b'. 0=The pin for BGPO[i] functions as a GPIO. When VTR is powered, the pin associated with BGPO[i] is determined by the GPIO associated with the pin. When VTR is unpowered, the pin is tri-stated</p>	R/W	1Fh	RESET_VBAT
0	BGPO0	RO	1	RESET_VBAT

MEC1725

26.11.10 BGPO RESET REGISTER

Offset	24h			
Bits	Description	Type	Default	Reset Event
31:6	Reserved	RES	-	-
5:0	BGPO_RESET Battery powered General Purpose Output reset event. For each bit [j] in the field: 1=BGPO[j] is reset to 0 on RESET_VBAT 0=BGPO[j] is reset to 0 on RESET_SYS	R/W	0h	RESET_VBAT

Note: Refer to [Table 2.3, "Pin List"](#) to find the number of BGPOs supported in the chip

27.0 TACH

27.1 Introduction

This block monitors TACH output signals (or locked rotor signals) from various types of fans, and determines their speed.

27.2 Interface

This block is designed to be accessed externally via the pin interface and internally via a registered host interface.

FIGURE 27-1: I/O DIAGRAM OF BLOCK

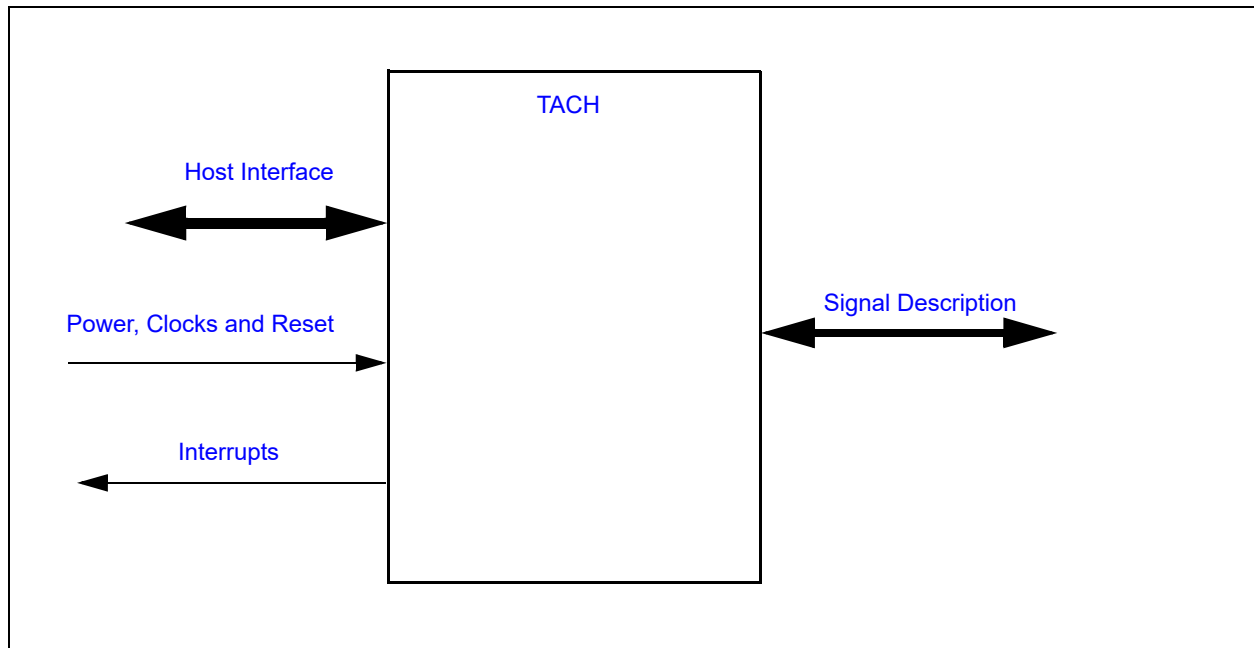

27.3 Signal Description

TABLE 27-1: SIGNAL DESCRIPTION

Name	Direction	Description
TACH INPUT	Input	Tachometer signal from TACHx Pin.

27.4 Host Interface

The registers defined for the **TACH** are accessible by the various hosts as indicated in [Section 3.2, "Block Overview and Base Addresses"](#).

27.5 Power, Clocks and Reset

This section defines the Power, Clock, and Reset parameters of the block.

27.5.1 POWER DOMAINS

Name	Description
VTR_CORE	The logic and registers implemented in this block are powered by this power well.

MEC1725

27.5.2 CLOCK INPUTS

Name	Description
100KHz	This is the clock input to the tachometer monitor logic. In Mode 1, the TACH is measured in the number of these clocks. This clock is derived from the main clock domain.

27.5.3 RESETS

Name	Description
RESET_SYS	This signal resets all the registers and logic in this block to their default state.

27.6 Interrupts

This section defines the Interrupt Sources generated from this block.

TABLE 27-2: EC INTERRUPTS

Source	Description
TACH	This internal signal is generated from the OR'd result of the status events, as defined in the TACHx Status Register .

27.7 Low Power Modes

The [TACH](#) may be put into a low power state by the chip's Power, Clocks, and Reset (PCR) circuitry.

27.8 Description

The [TACH](#) block monitors Tach output signals or locked rotor signals generated by various types of fans. These signals can be used to determine the speed of the attached fan. This block is designed to monitor fans at fan speeds from 100 RPMs to 30,000 RPMs.

Typically, these are DC brushless fans that generate (with each revolution) a 50% duty cycle, two-period square wave, as shown in [Figure 27-2](#) below.

FIGURE 27-2: FAN GENERATED 50%DUTY CYCLE WAVEFORM

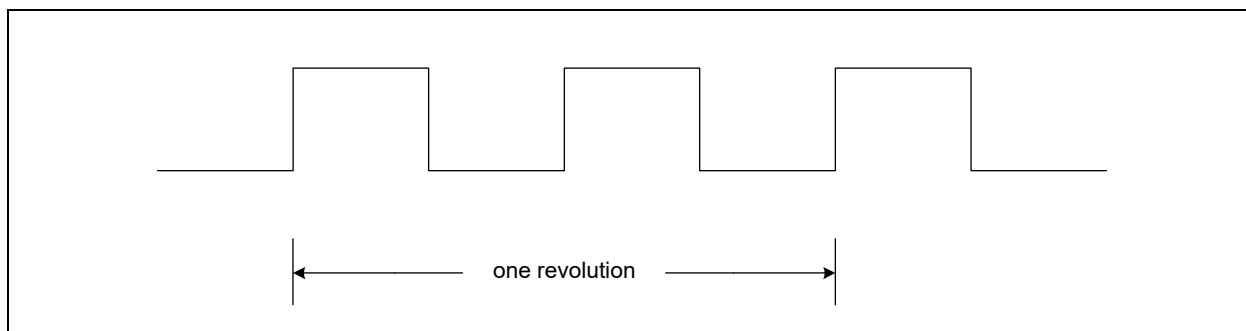

In typical systems, the fans are powered by the main power supply. Firmware may disable this block when it detects that the main power rail has been turned off by either clearing the <enable> [TACH_ENABLE](#) bit or putting the block to sleep via the supported Low Power Mode interface (see [Low Power Modes](#)).

27.8.1 MODES OF OPERATION

The Tachometer block supports two modes of operation. The mode of operation is selected via the [TACH_READING_MODE_SELECT](#) bit.

27.8.1.1 Free Running Counter

In Mode 0, the Tachometer block uses the TACH input as the clock source for the internal TACH pulse counter (see [TACHX_COUNTER](#)). The counter is incremented when it detects a rising edge on the TACH input. In this mode, the firmware may periodically poll the [TACHX_COUNTER](#) field to determine the average speed over a period of time. The firmware must store the previous reading and the current reading to compute the number of pulses detected over a period of time. In this mode, the counter continuously increments until it reaches FFFFh. It then wraps back to 0000h and continues counting. The firmware must ensure that the sample rate is greater than the time it takes for the counter to wrap back to the starting point.

Note: Tach interrupts should be disabled in Mode 0.

27.8.1.2 Mode 1 -- Number of Clock Pulses per Revolution

In Mode 1, the Tachometer block uses its 100KHz clock input to measure the programmable number of TACH pulses. In this mode, the internal TACH pulse counter ([TACHX_COUNTER](#)) returns the value in number of 100KHz pulses per programmed number of [TACH_EDGES](#). For fans that generate two square waves per revolution, these bits should be configured to five edges.

When the number of edges is detected, the counter is latched and the [COUNT_READY_STATUS](#) bit is asserted. If the [COUNT_READY_INT_EN](#) bit is set a TACH interrupt event will be generated.

27.8.2 OUT-OF-LIMIT EVENTS

The TACH Block has a pair of limit registers that may be configured to generate an event if the Tach indicates that the fan is operating too slow or too fast. If the <TACH reading> exceeds one of the programmed limits, the [TACHx High Limit Register](#) and the [TACHx Low Limit Register](#), the bit [TACH_OUT_OF_LIMIT_STATUS](#) will be set. If the [TACH_OUT_OF_LIMIT_STATUS](#) bit is set, the Tachometer block will generate an interrupt event.

27.9 EC Registers

Registers for this block are shown in the following summary table. Addresses for each register are determined by adding the offset to the Base Address for each instance of the [TACH](#) Block in the Block Overview and Base Address Table in [Section 3.0, "Device Inventory"](#).

TABLE 27-3: REGISTER SUMMARY

Offset	Register Name
00h	TACHx Control Register
04h	TACHx Status Register
08h	TACHx High Limit Register
0Ch	TACHx Low Limit Register

MEC1725

27.9.1 TACHX CONTROL REGISTER

Offset	00h			
Bits	Description	Type	Default	Reset Event
31:16	<p>TACHX_COUNTER</p> <p>This 16-bit field contains the latched value of the internal Tach pulse counter, which may be configured by the Tach Reading Mode Select field to operate as a free-running counter or to be gated by the Tach input signal.</p> <p>If the counter is free-running (Mode 0), the internal Tach counter increments (if enabled) on transitions of the raw Tach input signal and is latched into this field every time it is incremented. The act of reading this field will not reset the counter, which rolls over to 0000h after FFFFh. The firmware will compute the delta between the current count reading and the previous count reading, to determine the number of pulses detected over a programmed period.</p> <p>If the counter is gated by the Tach input and clocked by 100KHz (Mode 1), the internal counter will be latched into the reading register when the programmed number of edges is detected or when the counter reaches FFFFh. The internal counter is reset to zero after it is copied into this register.</p> <p>Note: In Mode 1, a counter value of FFFFh means that the Tach did not detect the programmed number of edges in 655ms. A stuck fan can be detected by setting the TACHx High Limit Register to a number less than FFFFh. If the internal counter then reaches FFFFh, the reading register will be set to FFFFh and an out-of-limit interrupt can be sent to the EC.</p>	R	00h	RESET_SYS
15	<p>TACH_INPUT_INT_EN</p> <p>1=Enable Tach Input toggle interrupt from Tach block 0=Disable Tach Input toggle interrupt from Tach block</p>	R/W	0b	RESET_SYS
14	<p>COUNT_READY_INT_EN</p> <p>1=Enable Count Ready interrupt from Tach block 0=Disable Count Ready interrupt from Tach block</p>	R/W	0b	RESET_SYS
13	Reserved	RES	-	-
12:11	<p>TACH_EDGES</p> <p>A Tach signal is a square wave with a 50% duty cycle. Typically, two Tach periods represents one revolution of the fan. A Tach period consists of three Tach edges.</p> <p>This programmed value represents the number of Tach edges that will be used to determine the interval for which the number of 100KHz pulses will be counted</p> <p>11b=9 Tach edges (4 Tach periods) 10b=5 Tach edges (2 Tach periods) 01b=3 Tach edges (1 Tach period) 00b=2 Tach edges (1/2 Tach period)</p>	R/W	00b	RESET_SYS

Offset	00h			
Bits	Description	Type	Default	Reset Event
10	<p>TACH_READING_MODE_SELECT</p> <p>1=Counter is incremented on the rising edge of the 100KHz input. The counter is latched into the TACHX_COUNTER field and reset when the programmed number of edges is detected.</p> <p>0=Counter is incremented when Tach Input transitions from low-to-high state (default)</p>	R/W	0b	RESET_SYS
9	Reserved	RES	-	-
8	<p>FILTER_ENABLE</p> <p>This filter is used to remove high frequency glitches from Tach Input. When this filter is enabled, Tach input pulses less than two 100KHz periods wide get filtered.</p> <p>1=Filter enabled 0=Filter disabled (default)</p> <p>It is recommended that the Tach input filter always be enabled.</p>	R/W	0b	RESET_SYS
7:2	Reserved	RES	-	-
1	<p>TACH_ENABLE</p> <p>This bit gates the clocks into the block. When clocks are gated, the TACHx pin is tristated. When re-enabled, the internal counters will continue from the last known state and stale status events may still be pending. Firmware should discard any status or reading values until the reading value has been updated at least one time after the enable bit is set.</p> <p>1=TACH Monitoring enabled, clocks enabled. 0=TACH Idle, clocks gated</p>	R/W	0b	RESET_SYS
0	<p>TACH_OUT_OF_LIMIT_ENABLE</p> <p>This bit is used to enable the TACH_OUT_OF_LIMIT_STATUS bit in the TACHx Status Register to generate an interrupt event.</p> <p>1=Enable interrupt output from Tach block 0=Disable interrupt output from Tach block (default)</p>	R/W	0b	RESET_SYS

MEC1725

27.9.2 TACHX STATUS REGISTER

Offset	04h			
Bits	Description	Type	Default	Reset Event
31:4	Reserved	RES	-	-
3	<p>COUNT_READY_STATUS</p> <p>This status bit is asserted when the Tach input changes state and when the counter value is latched. This bit remains cleared to '0' when the TACH_READING_MODE_SELECT bit in the TACHx Control Register is '0'. When the TACH_READING_MODE_SELECT bit in the TACHx Control Register is set to '1', this bit is set to '1' when the counter value is latched by the hardware. It is cleared when written with a '1'. If COUNT_READY_INT_EN in the TACHx Control Register is set to 1, this status bit will assert the Tach Interrupt signal.</p> <p>1=Reading ready 0=Reading not ready</p>	R/WC	0b	RESET_SYS
2	<p>TOGGLE_STATUS</p> <p>This bit is set when Tach Input changes state. It is cleared when written with a '1b'. If TACH_INPUT_INT_EN in the TACHx Control Register is set to '1b', this status bit will assert the Tach Interrupt signal.</p> <p>1=Tach Input changed state (this bit is set on a low-to-high or high-to-low transition) 0=Tach stable</p>	R/WC	0b	RESET_SYS
1	<p>TACH_PIN_STATUS</p> <p>This bit reflects the state of Tach Input. This bit is a read only bit that may be polled by the embedded controller.</p> <p>1=Tach Input is high 0=Tach Input is low</p>	R	0b	RESET_SYS
0	<p>TACH_OUT_OF_LIMIT_STATUS</p> <p>This bit is set when the Tach Count value is greater than the high limit or less than the low limit. It is cleared when written with a '1b'. To disable this status event set the limits to their extreme values. If TACH_OUT_OF_LIMIT_ENABLE in the TACHx Control Register is set to 1, this status bit will assert the Tach Interrupt signal.</p> <p>1=Tach is outside of limits 0=Tach is within limits</p>	R/WC	0b	RESET_SYS

Note:

- Some fans offer a Locked Rotor output pin that generates a level event if a locked rotor is detected. This bit may be used in combination with the Tach pin status bit to detect a locked rotor signal event from a fan.
- Tach Input may come up as active for Locked Rotor events. This would not cause an interrupt event because the pin would not toggle. Firmware must read the status events as part of the initialization process, if polling is not implemented.

27.9.3 TACHX HIGH LIMIT REGISTER

Offset	08h			
Bits	Description	Type	Default	Reset Event
31:16	Reserved	RES	-	-
15:0	<p>TACH_HIGH_LIMIT</p> <p>This value is compared with the value in the TACHX_COUNTER field. If the value in the counter is greater than the value programmed in this register, the TACH_OUT_OF_LIMIT_STATUS bit will be set. The TACH_OUT_OF_LIMIT_STATUS status event may be enabled to generate an interrupt to the embedded controller via the TACH_OUT_OF_LIMIT_ENABLE bit in the TACHx Control Register.</p>	R/W	FFFFh	RESET_SYS

27.9.4 TACHX LOW LIMIT REGISTER

Offset	0Ch			
Bits	Description	Type	Default	Reset Event
31:16	Reserved	RES	-	-
15:0	<p>TACHX_LOW_LIMIT</p> <p>This value is compared with the value in the TACHX_COUNTER field of the TACHx Control Register. If the value in the counter is less than the value programmed in this register, the TACH_OUT_OF_LIMIT_STATUS bit will be set. The TACH_OUT_OF_LIMIT_STATUS status event may be enabled to generate an interrupt to the embedded controller via the TACH_OUT_OF_LIMIT_ENABLE bit in the TACHx Control Register</p> <p>To disable the TACH_OUT_OF_LIMIT_STATUS low event, program 0000h into this register.</p>	R/W	0000h	RESET_SYS

MEC1725

28.0 PWM

28.1 Introduction

This block generates a PWM output that can be used to control 4-wire fans, blinking LEDs, and other similar devices. Each PWM can generate an arbitrary duty cycle output at frequencies from less than 0.1 Hz to 24 MHz.

The PWMx Counter ON Time registers and PWMx Counter OFF Time registers determine the operation of the PWM_OUTPUT signals. See [Section 28.9.1, "PWMx Counter ON Time Register"](#) and [Section 28.9.2, "PWMx Counter OFF Time Register"](#) for a description of the PWM_OUTPUT signals.

28.2 Interface

This block is designed to be accessed externally via the pin interface and internally via a registered host interface.

FIGURE 28-1: I/O DIAGRAM OF BLOCK

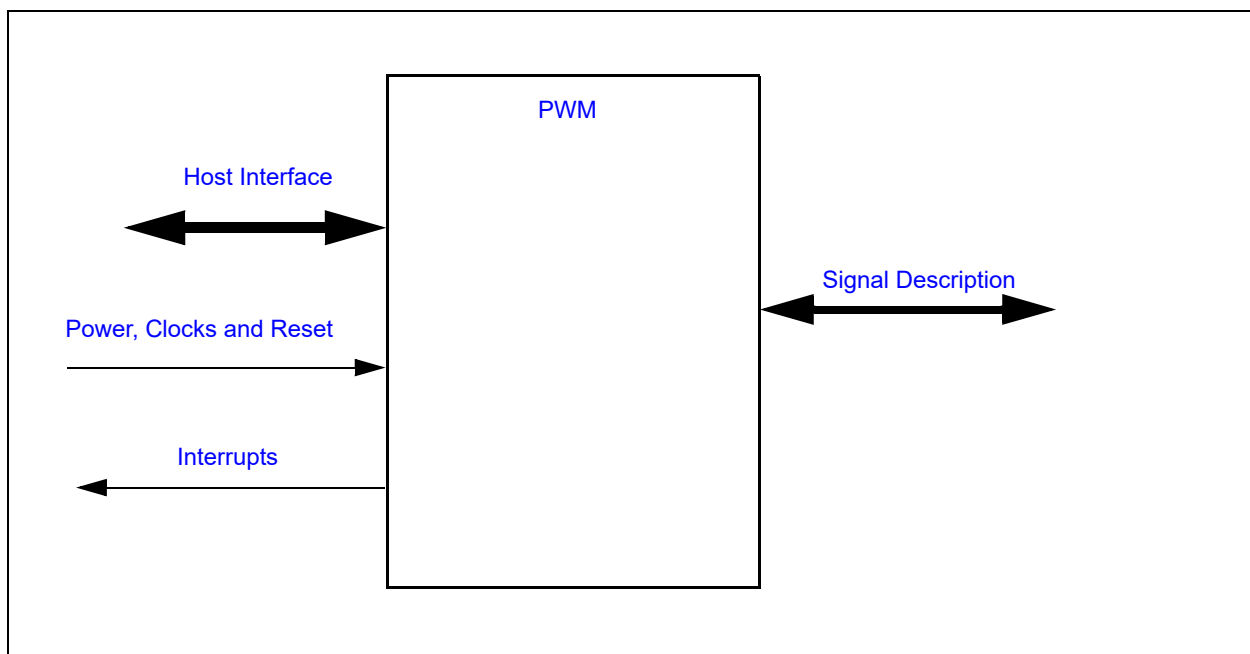

28.3 Signal Description

TABLE 28-1: SIGNAL DESCRIPTION

Name	Direction	Description
PWMx	OUTPUT	Pulse Width Modulated signal to PWMx pin.

28.4 Host Interface

The registers defined for the PWM Interface are accessible by the various hosts as indicated in [Section 3.2, "Block Overview and Base Addresses"](#).

28.5 Power, Clocks and Reset

This section defines the Power, Clock, and Reset parameters of the block.

28.5.1 POWER DOMAINS

Name	Description
VTR_CORE	The logic and registers implemented in this block are powered by this power well.

28.5.2 CLOCK INPUTS

Name	Description
48MHz	Clock input for generating high PWM frequencies, such as 15 kHz to 30 kHz.
100KHz	This is the clock input for generating low PWM frequencies, such as 10 Hz to 100 Hz.

28.5.3 RESETS

Name	Description
RESET_SYS	This signal resets all the registers and logic in this block to their default state.

28.6 Interrupts

The PWM block does not generate any interrupt events.

28.7 Low Power Modes

The [PWM](#) may be put into a low power state by the chip's Power, Clocks, and Reset (PCR) circuitry. When the PWM is in the sleep state, the internal counters reset to 0 and the internal state of the PWM and the PWM_OUTPUT signal set to the OFF state.

28.8 Description

The PWM_OUTPUT signal is used to generate a duty cycle of specified frequency. This block can be programmed so that the PWM signal toggles the PWM_OUTPUT, holds it high, or holds it low. When the PWM is configured to toggle, the PWM_OUTPUT alternates from high to low at the rate specified in the [PWMx Counter ON Time Register](#) and [PWMx Counter OFF Time Register](#).

The following diagram illustrates how the clock inputs and registers are routed to the PWM Duty Cycle & Frequency Control logic to generate the PWM output.

FIGURE 28-2: BLOCK DIAGRAM OF PWM CONTROLLER

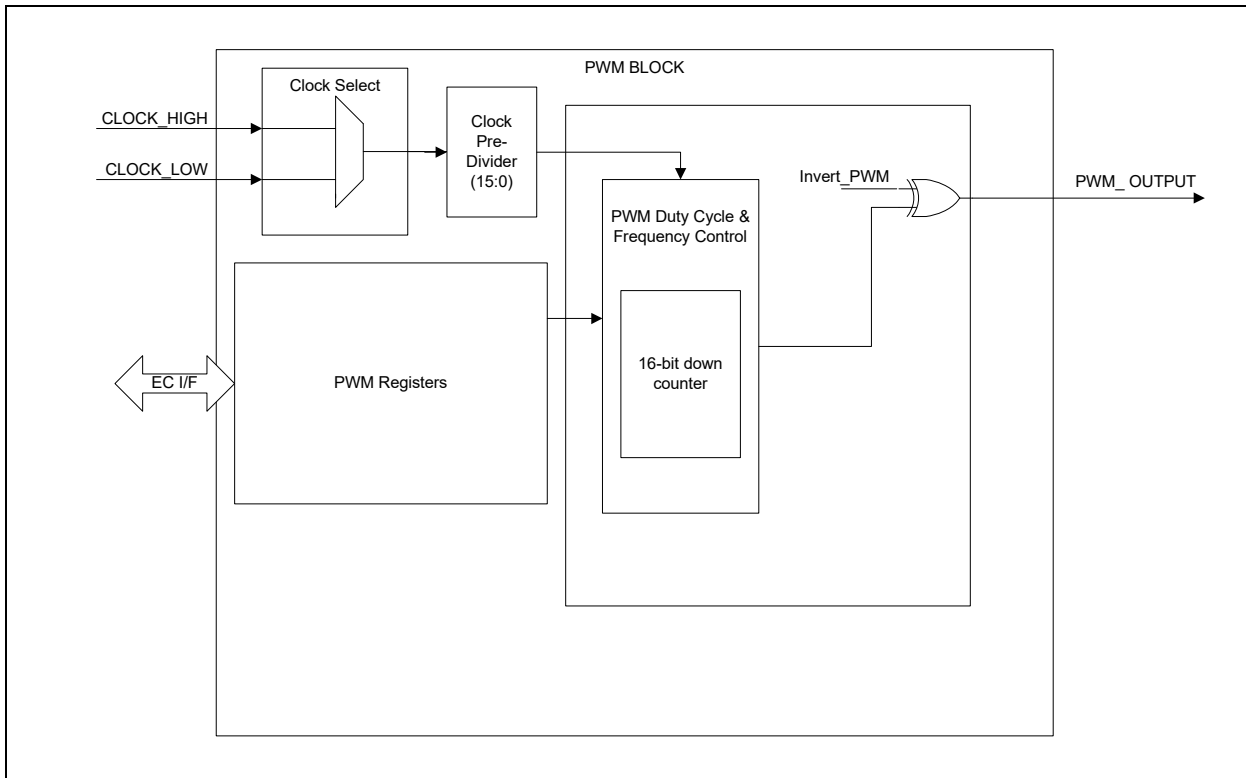

Note: In Figure 28-2, the 48MHz clock is represented as CLOCK_HIGH and the 100KHz clock is represented as CLOCK_LOW.

The PWM clock source to the PWM Down Counter, used to generate a duty cycle and frequency on the PWM, is determined through the Clock select[1] and Clock Pre-Divider[6:3] bits in the [PWMx Configuration Register](#) register.

The PWMx Counter ON/OFF Time registers determine both the frequency and duty cycle of the signal generated on PWM_OUTPUT as described below.

The PWM frequency is determined by the selected clock source and the total on and off time programmed in the [PWMx Counter ON Time Register](#) and [PWMx Counter OFF Time Register](#) registers. The frequency is the time it takes (at that clock rate) to count down to 0 from the total on and off time.

The PWM duty cycle is determined by the relative values programmed in the [PWMx Counter ON Time Register](#) and [PWMx Counter OFF Time Register](#) registers.

The [PWM Frequency Equation](#) and [PWM Duty Cycle Equation](#) are shown below.

EQUATION 28-1: PWM FREQUENCY EQUATION

$$\text{PWM Frequency} = \frac{1}{(\text{PreDivisor} + 1)} \times \frac{(\text{ClockSourceFrequency})}{((\text{PWMCounterOnTime} + 1) + (\text{PWMCounterOffTime} + 1))}$$

In this equation, the ClockSourceFrequency variable is the frequency of the clock source selected by the Clock Select bit in the [PWMx Configuration Register](#), and PreDivisor is a field in the [PWMx Configuration Register](#). The PWMCounterOnTime, PWMCounterOffTime are registers that are defined in [Section 28.9, "EC Registers"](#).

EQUATION 28-2: PWM DUTY CYCLE EQUATION

$$\text{PWM Duty Cycle} = \frac{(PWMCounterOnTime + 1)}{((PWMCounterOnTime + 1) + (PWMCounterOffTime + 1))}$$

The [PWMx Counter ON Time Register](#) and [PWMx Counter OFF Time Register](#) registers should be accessed as 16-bit values.

28.8.1 PWM REGISTER UPDATES

The [PWMx Counter ON Time Register](#) and [PWMx Counter OFF Time Register](#) may be updated at any time. Values written into the two registers are kept in holding registers. The holding registers are transferred into the two user-visible registers when all four bytes have been written with new values and the internal counter completes the OFF time count. If the PWM is in the Full On state then the two user-visible registers are updated from the holding registers as soon as all four bytes have been written. Once the two registers have been updated the holding registers are marked empty, and all four bytes must again be written before the holding registers will be reloaded into the On Time Register and the Off Time Register. Reads of both registers return the current contents of the registers that are used to load the counter and not the holding registers.

28.9 EC Registers

Registers for this block are shown in the following summary table. Addresses for each register are determined by adding the offset to the Base Address for each instance of the [PWM](#) Block in the Block Overview and Base Address Table in [Section 3.0, "Device Inventory"](#).

TABLE 28-2: REGISTER SUMMARY

Offset	Register Name
00h	PWMx Counter ON Time Register
04h	PWMx Counter OFF Time Register
08h	PWMx Configuration Register

28.9.1 PWMX COUNTER ON TIME REGISTER

Offset	00h			
Bits	Description	Type	Default	Reset Event
31:16	Reserved	RES	-	-
15:0	<p>PWMX_COUNTER_ON_TIME</p> <p>This field determine both the frequency and duty cycle of the PWM signal. Setting this field to a value of n will cause the On time of the PWM to be $n+1$ cycles of the PWM Clock Source.</p> <p>When this field is set to zero and the PWMX_COUNTER_OFF_TIME is not set to zero, the PWM_OUTPUT is held low (Full Off).</p>	R/W	0000h	RESET_SYS

MEC1725

28.9.2 PWMX COUNTER OFF TIME REGISTER

Offset	04h			
Bits	Description	Type	Default	Reset Event
31:16	Reserved	RES	-	-
15:0	<p>PWMX_COUNTER_OFF_TIME</p> <p>This field determine both the frequency and duty cycle of the PWM signal. Setting this field to a value of n will cause the Off time of the PWM to be $n+1$ cycles of the PWM Clock Source.</p> <p>When this field is set to zero, the PWM_OUTPUT is held high (Full On).</p>	R/W	FFFFh	RESET_SYS

28.9.3 PWMX CONFIGURATION REGISTER

Offset	08h			
Bits	Description	Type	Default	Reset Event
31:7	Reserved	RES	-	-
6:3	<p>CLOCK_PRE_DIVIDER</p> <p>The Clock source for the 16-bit down counter (see PWMx Counter ON Time Register and PWMx Counter OFF Time Register) is determined by bit D1 of this register. The Clock source is then divided by the value of Pre-Divider+1 and the resulting signal determines the rate at which the down counter will be decremented. For example, a Pre-Divider value of 1 divides the input clock by 2 and a value of 2 divides the input clock by 3. A Pre-Divider of 0 will disable the Pre-Divider option.</p>	R/W	0000b	RESET_SYS
2	<p>INVERT</p> <p>1=PWM_OUTPUT ON State is active low 0=PWM_OUTPUT ON State is active high</p>	R/W	0b	RESET_SYS
1	<p>CLOCK_SELECT</p> <p>This bit determines the clock source used by the PWM duty cycle and frequency control logic.</p> <p>1=CLOCK_LOW 0=CLOCK_HIGH</p>	R/W	0b	RESET_SYS
0	<p>PWM_ENABLE</p> <p>When the PWM_ENABLE is set to 0 the internal counters are reset and the internal state machine is set to the OFF state. In addition, the PWM_OUTPUT signal is set to the inactive state as determined by the Invert bit. The PWMx Counter ON Time Register and PWMx Counter OFF Time Register are not affected by the PWM_ENABLE bit and may be read and written while the PWM enable bit is 0.</p> <p>1=Enabled (default) 0=Disabled (gates clocks to save power)</p>	R/W	0b	RESET_SYS

29.0 PECE INTERFACE

29.1 Overview

The MEC1725 includes a [PECE Interface](#) to allow the EC to retrieve temperature readings from PECE-compliant devices. The [PECE Interface](#) implements the PHY and Link Layer of a PECE host controller as defined in [References](#)[1] and includes hardware support for the PECE 3.1 command set.

This chapter focuses on MEC1725-specific [PECE Interface](#) configuration information such as [Power Domains](#), [Clock Inputs](#), [Resets](#), [Interrupts](#), and other chip specific information. For a functional description of the MEC1725 [PECE Interface](#) refer to [References](#) [1].

29.2 References

1. PECE Interface Core, Rev. 1.31, Core-Level Architecture Specification, Microchip Confidential, 4/15/11

29.3 Terminology

No terminology has been defined for this chapter.

29.4 Interface

This block is designed to be accessed externally via the pin interface and internally via a registered host interface.

FIGURE 29-1: PECE INTERFACE I/O DIAGRAM

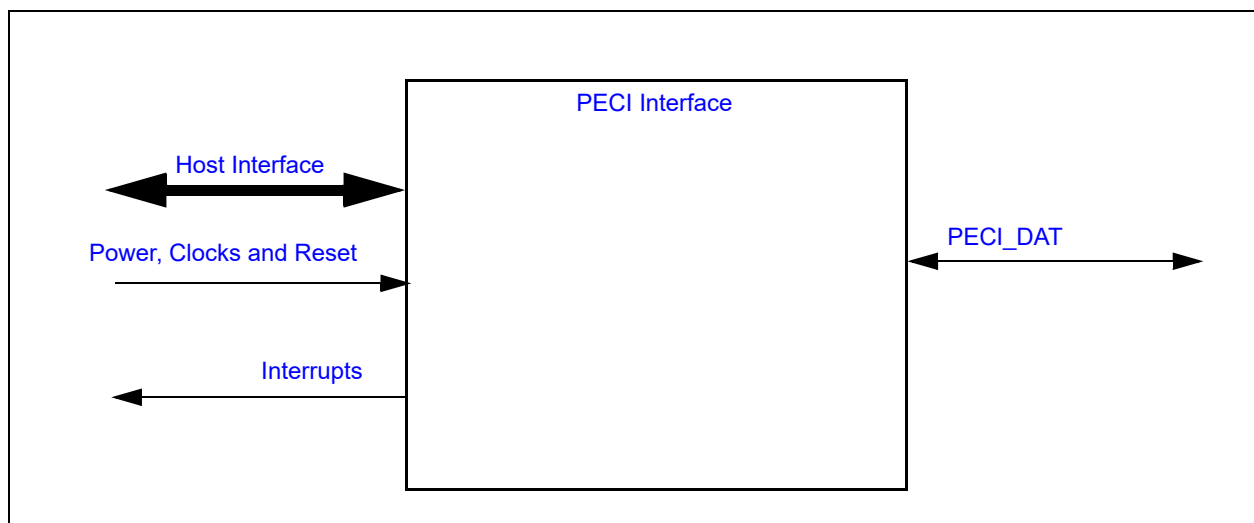

29.5 Signal Description

The Signal Description Table lists the signals that are typically routed to the pin interface.

TABLE 29-1: SIGNAL DESCRIPTION

Name	Direction	Description
PECE_DAT	Input/Output	PECE Data signal pin

Note: Routing guidelines for the PECE_DAT pin is provided in Intel Platform design guides. Refer to the appropriate Intel document for current information. See [Table 29-2](#).

MEC1725

TABLE 29-2: PECE ROUTING GUIDELINES

Trace Impedance	50 Ohms +/- 15%
Spacing	10 mils
Routing Layer	Microstrip
Trace Width	Calculate to match impedance
Length	1" - 15"

29.6 Host Interface

The registers defined for the [PECE Interface](#) are accessible by the various hosts as indicated in [Section 3.2, "Block Overview and Base Addresses"](#).

29.7 Power, Clocks and Reset

This section defines the Power, Clock, and Reset parameters of the block.

29.7.1 POWER DOMAINS

Name	Description
VTR_CORE	The logic and registers implemented in this block are powered by this power well.

29.7.2 CLOCK INPUTS

Name	Description
48MHz	This is the main system clock.
PECE_CORE_CLK	This is the PECE_CORE_CLK derived from the 48MHz . This clock divided by the OPTIMAL BIT TIME REGISTER value will generate the bit clock for the PECE_DAT .

29.7.3 RESETS

Name	Description
RESET_SYS	This signal resets all the registers and logic in this block to their default state.
RST	This is the Soft reset to the PECE block, and resets all the registers and logic to their default state

29.8 Interrupts

This section defines the Interrupt Sources generated from this block.

TABLE 29-3: EC INTERRUPTS

Source	Description
PECE_INT	PECE Host Event

29.9 Low Power Modes

The [PECE Interface](#) may be put into a low power state by the chip's Power, Clocks, and Reset (PCR) circuitry.

29.10 Instance Description

There is one instance of the PECE Core implemented in the [PECE Interface](#) in the MEC1725. See Reference [1], [PECE Interface Core, Rev. 1.31, Core-Level Architecture Specification, Microchip Confidential, 4/15/11](#), for a description of the PECE Core.

Note: If the PECE interface is not in use, the [PECE_DISABLE](#) bit in the [PECE Disable Register](#) must be set to '1b' in order to minimize leakage current.

29.11 EC Registers

Registers for this block are shown in the following summary table. Addresses for each register are determined by adding the offset to the Base Address for each instance of the [PECE Interface](#) Block in the Block Overview and Base Address Table in [Section 3.0, "Device Inventory"](#).

TABLE 29-4: REGISTER SUMMARY

Offset	Register Name
00h	WRITE DATA Register
04h	READ DATA Register
08h	CONTROL Register
0Ch	STATUS Register 1
10h	STATUS Register 2
14h	ERROR Register
18h	Interrupt Enable 1 Register
1Ch	Interrupt Enable 2 Register
20h	Optimal Bit Time Register (LOW BYTE)
24h	Optimal Bit Time Register (HIGH BYTE)
28h	TEST
2Ch	TEST
30h	PECE Baud Control Register
40h	PECE Block ID Register
44h	PECE Revision Register
48h	PECEHOST-SSTCTL1 Register
48h - 7Ch	Test

29.11.1 WRITE DATA REGISTER

Offset	00h			
Bits	Description	Type	Default	Reset Event
7:0	Write Data. The Write Data Register provides access to a 32-byte Transmit FIFO. The Write Data Register status indicators WFF , WFE , WROV and WRUN can affect the Interrupt. The Transmit FIFO pointers as well as status indicators WFF and WFE are reset to their default values when the FRST bit in the Control Register is asserted.	R/W	00h	RESETSYS

MEC1725

29.11.2 READ DATA REGISTER

Offset	04h			
Bits	Description	Type	Default	Reset Event
7:0	Read Data. The Read Data Register provides access to a 32-byte Receive FIFO. The Read Data Register status indicators RFF , RFE , RDOV can affect the Interrupt. The Receive FIFO pointers as well as status indicators RFF and RFE are reset to their default values when the FRST bit in the Control Register is asserted.	R/W	00h	RESETSYS

29.11.3 CONTROL REGISTER

Offset	08h			
Bits	Description	Type	Default	Reset Event
7	MIEN Master Interrupt enable	R/W	00h	RESETSYS
6	TXEN TXEN is the Transmit Enable bit. When TXEN is not asserted ('0') Message Transmission is disabled; and data can be queued into the transmit FIFO using the Write Data Register. TXEN is asserted by software and de-asserted by hardware following EOF .	R/W	0	RESETSYS
5	FRST FRST is the FIFO Reset bit. When FRST is asserted '1,' the Transmit FIFO and the Receive FIFO are reset and the FIFO status indicators in STATUS Register 2 are returned to their default state. The FRST bit is only controlled by software and must be de-asserted by the host before continuing normal operation.	R/W	0	RESETSYS
4	Reserved	RES	0	
3	RST RST is PECL Core Soft reset. The RST bit must be de-asserted by the host before continuing the normal operation. 0- Normal operation 1- in reset.	R/W	0	RESETSYS
2:1	Reserved	RES	00	
0	PD Power Down (PD) along with RST controls the entry and exit from the Low Power modes. RST and PD can be asserted at the same time.	R/W	1	RESETSYS

29.11.4 STATUS REGISTER 1

Offset	0Ch			
Bits	Description	Type	Default	Reset Event
7	MINT MINT is the Master Interrupt Status bit. MINT is asserted when any of the interrupt status bit is set and de-asserted when all of the interrupt status bits are cleared. The MINT interrupt enable bit (MIEN) is located in the CONTROL Register .	R	0h	RESETSYS
6	Reserved	RES	-	-

Offset	0Ch			
Bits	Description	Type	Default	Reset Event
2	ERR ERR Indicates that an error for the current transaction has been detected. This bit will be set when any of the conditions in the ERROR Register are asserted. The ERR bit remains set until the offending condition(s) is eliminated.	R	0	RESET_S YS
1	EOF EOF (End of Frame) is asserted following Message Stop.	R/WC	0	RESET_S YS
0	BOF BOF (Beginning of Frame) is asserted when the PECL Core begins Address Timing Negotiation.	R/WC	0	RESET_S YS

29.11.5 STATUS REGISTER 2

Offset	10h			
Bits	Description	Type	Default	Reset Event
7	IDLE The IDLE status bit indicates when the PECL bus is idle and a new transaction may begin. IDLE is de-asserted during a PECL message transaction and asserted following the Message Setup Time. The host must only initiate PECL transactions when IDLE is asserted. Note that the IDLE status bit does not generate an interrupt.	R	1h	RESET_S YS
6:4	RSVD	R	0	
3	RFE RFE indicates that the Read Data Register FIFO is empty. RFE does not generate an interrupt.	R	1	RESET_S YS
2	RFF RFF indicates that the Read Data Register FIFO is full.	R	0	RESET_S YS
1	WFE WFE indicates that the Write Data Register FIFO is empty.	R	1	RESET_S YS
0	WFF WFF indicates that the Write Data Register FIFO is full. WFF does not generate an interrupt.	R	0	RESET_S YS

MEC1725

29.11.6 ERROR REGISTER

Software handles the bulk of the error recovery process. The different error conditions are captured in this register.

Offset	14h			
Bits	Description	Type	Default	Reset Event
7	CLKERR CLKERR indicates that the READY signal function was de-asserted in the middle of a transaction. In the event of a Clock Error, the PECE Core hardware completes the message normally (EOF) with incorrect data in the Receive FIFO and an FERR.	R/WC	0h	RESET_S YS
6	RDOV Read Overrun, RDOV indicates that the internal read buffer has overflowed. In the event of a Read Buffer Overrun, the PECE Core hardware completes the message normally (EOF) with incorrect data in the Receive FIFO.	R/WC	0	RESET_S YS
5	WRUN Write Underrun, WRUN is set by the PECE Core hardware to indicate that the host did not write data required to be sent over the PECE Bus i.e., the internal write buffer is empty, but data must be sent according to the protocol.	R/WC	0	RESET_S YS
4	WROV Write Overrun, WROV is set by the PECE Core hardware to indicate that the data byte written to the Input register has been ignored since the transmit buffer is full. In this case, the controller takes no action, the data written is ignored, and the transaction continues normally.	R/WC	0	RESET_S YS
3	Reserved	RES	-	
2	Reserved	RES	-	-
1	BERR Bus Error, Bus contention has been detected. BERR is asserted when the PECE host controller reads a value that is different from what it has driven. Following Message Transmit Initiation if the PECE bus is stuck high the BERR is asserted. Note that the BERR bit is the only indication that a PECE Bus Stuck-High Fault has been detected; the IDLE and EOF bits are never re-asserted, TXEN is never de-asserted. A Reset must be asserted after a PECE Bus Stuck-High Fault has been detected.	R/WC	0	RESET_S YS
0	FERR Frame Check Sequence Error occurs when the controller calculates a FCS value that is different from that returned by the target. In the case of a Frame Check Sequence Error the FERR bit is asserted and the transaction continues normally.	R/WC	0	RESET_S YS

29.11.7 INTERRUPT ENABLE 1 REGISTER

Offset	18h			
Bits	Description	Type	Default	Reset Event
7:6	Reserved	RES	0h	
3	Reserved	RES	0	
2	EREN When the EREN bit is asserted '1' the ERR interrupt is enabled.	R/W	0	RESET_S YS
1	EIEN When the EIEN bit is asserted '1' the EOF interrupt is enabled.	R/W	0	RESET_S YS
0	BIEN When the BIEN bit is asserted '1' the BOF interrupt is enabled.	R/W	0	RESET_S YS

29.11.8 INTERRUPT ENABLE 2 REGISTER

Offset	1Ch			
Bits	Description	Type	Default	Reset Event
7:3	Reserved	RES	0h	-
2	ENRFF When the ENRFF bit is asserted '1' the RFF interrupt is enabled.	R/W	0	RESET_S YS
1	ENWFE When the ENWFE bit is asserted '1' the WFE interrupt is enabled.	R/W	0	RESET_S YS
0	Reserved	RES	0	-

29.11.9 OPTIMAL BIT TIME REGISTER

The 16-bit Optimal Bit Time Register determines the 'high' pulse width driven by the host during speed negotiation phases for all PECL transactions. The Optimal Bit Time Register includes the Optimal Bit Time Register (Low Byte) and the Optimal Bit Time Register (High Byte). The 16-bit Optimal Bit Time Register determines PULSE (in seconds) according to the expression.

$$\text{PULSE} = \text{PERIOD} * \text{OBT}/4$$

PERIOD is the period of the **PECL_CORE_CLK** and OBT is the value in the Optimal Bit Time Register, **OBT reg value (Hex)**. The Host Optimal Bit Time (HOBT) (Hz) is determined according to the expression.

$$\text{HOBT} = 1/(\text{PULSE} * 4)$$

The **Optimal Bit Time Register (LOW BYTE)** and **Optimal Bit Time Register (HIGH BYTE)** can be written in any order but must not be written while a transaction is in process; i.e., while IDLE in **STATUS Register 2** is not asserted ('0').

TABLE 29-5: CORE CLOCK VS OBT REG VALUE FOR MAX. HOBT

Baud Value	3	4	1	1	1
PECL_CORE_CLK ^a (MHz)	16	12	48	48	48
OBT reg value ^b (Hex)	0x0020	0x0018	0x5DC0	0x0060	0x0030
OBT bit rate	500Kbps	500Kbps	2Kbps	500Kbps	1Mbps

a. The main system clock frequency is **48MHZ**.

b. Valid **OPTIMAL BIT TIME REGISTER** values are 0010h - FFFFh.

MEC1725

29.11.9.1 Optimal Bit Time Register (LOW BYTE)

Offset	20h			
Bits	Description	Type	Default	Reset Event
7:0	Optimal Bit Time Register Low byte Valid OBT low values are 10h to FFh	R/W	16h	RESET_S YS

29.11.9.2 Optimal Bit Time Register (HIGH BYTE)

Offset	24h			
Bits	Description	Type	Default	Reset Event
7:0	Optimal Bit Time Register High byte Valid OBT high values are 00h to FFh	R/W	00h	RESET_S YS

29.11.10 PECEI BAUD CONTROL REGISTER

Offset	30h			
Bits	Description	Type	Default	Reset Event
15:0	Baud Value This register is used to divide the main system clock (48MHz) with the Baud Value to generate the PECEI_CORE_CLK . By using this register, we can lower the dynamic power of the block.	R/W	0001h	RESET_S YS

29.11.11 PECEI BLOCK ID REGISTER

Offset	40h			
Bits	Description	Type	Default	Reset Event
31:0	Block ID Register This register contains the PECEI Interface Block ID.	R/W	000000C0h	RESET_S YS

29.11.12 PECEI REVISION REGISTER

Offset	44h			
Bits	Description	Type	Default	Reset Event
31:0	Revision Register This register contains the PECEI Interface revision number.	R/W	00000000h	RESET_S YS

29.11.13 PECEIHOST-SSTCTL1 REGISTER

Offset	48h			
Bits	Description	Type	Default	Reset Event
31:1	Reserved	RES	0	-

Offset	48h			
Bits	Description	Type	Default	Reset Event
0	PECIHOST-SSTCTL1 Register 0= Negotiated bit time value cannot be smaller than the optimal bit time. 1= Disable Normal bit time clamp (original behavior)	R/W	00000000h	RESET_S YS

MEC1725

30.0 ANALOG TO DIGITAL CONVERTER

30.1 Introduction

This block is designed to convert external analog voltage readings into digital values. It consists of a single successive-approximation Analog-Digital Converter that can be shared among multiple inputs with accuracy of +/- 4 LSB.

30.2 Interface

This block is designed to be accessed externally via the pin interface and internally via a registered host interface.

FIGURE 30-1: I/O DIAGRAM OF BLOCK

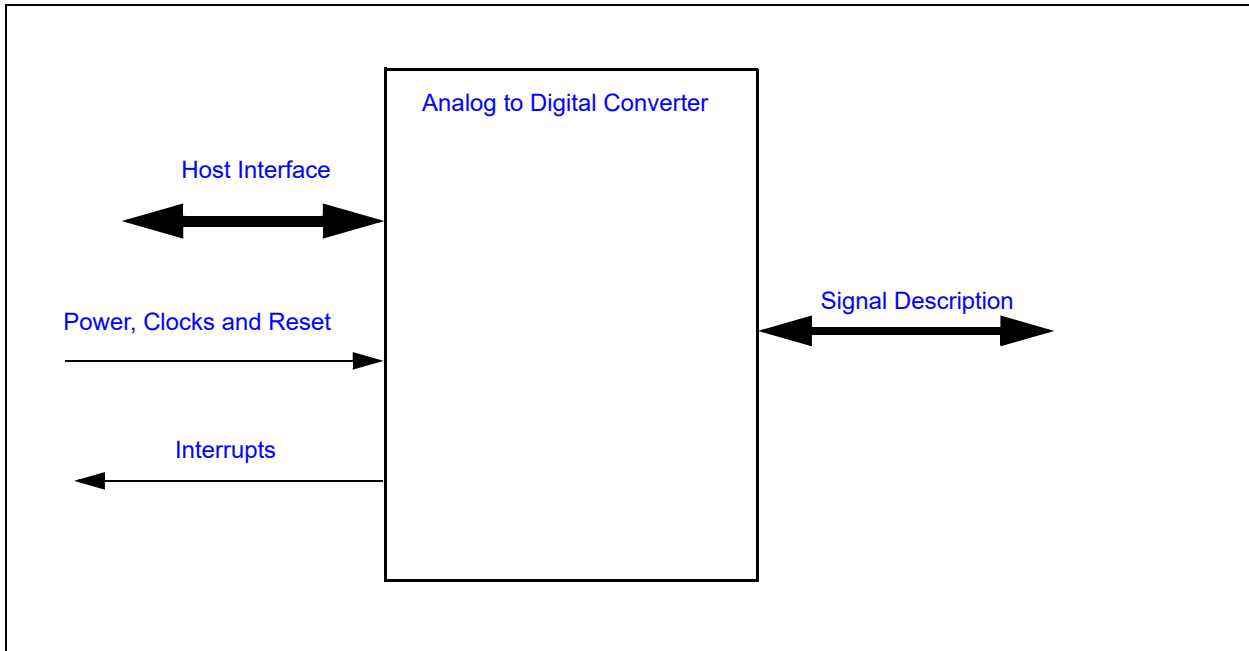

30.3 Signal Description

The Signal Description Table lists the signals that are typically routed to the pin interface.

TABLE 30-1: SIGNAL DESCRIPTION

Name	Direction	Description
ADC [15:0]	Input	ADC Analog Voltage Input from pins. Note: The ADC Controller supports up to 16 channels. The number of channels implemented is package dependent. Refer to the Pin Chapter for the number of channels implemented in a package.
VREF_ADC	Input	ADC Reference Voltage input. ADC Reference Voltage. This pin must either be connected to a very accurate 3.3V reference or connected to the same VTR_ANALOG power supply that is powering the ADC logic.

TABLE 30-1: SIGNAL DESCRIPTION

Name	Direction	Description
VREF2_ADC	Input	ADC Reference Voltage input. ADC Reference Voltage can have 2 sources. <ol style="list-style-type: none"> Internal Reference voltage sourced internal to the chip. This voltage will also be available on a GPIO pin for Thermistor reference voltage External Reference voltage fed through GPIO pin

30.4 Host Interface

The registers defined for the ADC are accessible by the various hosts as indicated in [Section 3.2, "Block Overview and Base Addresses"](#).

30.5 Power, Clocks and Reset

This section defines the Power, Clock, and Reset parameters of the block.

30.5.1 POWER DOMAINS

TABLE 30-2: POWER SOURCES

Name	Description
VTR_CORE	This power well supplies power for the registers in this block.
VTR_ANALOG	This power well supplies power for the analog circuitry in this block.

30.5.2 CLOCK INPUTS

TABLE 30-3: CLOCK INPUTS

Name	Description
48MHz	This clock signal is the master clock input to the ADC. This clock is internally divided to generate the ADC sampling clock. At 24MHz, the ADC does one channel conversion in 499.6nS for 12 bit resolution.

30.5.3 RESETS

TABLE 30-4: RESET SIGNALS

Name	Description
RESET_SYS	This reset signal resets all of the registers and logic in this block.
SOFT_RESET	This is the Soft reset to the block and resets the Hardware in this block and does not affect the registers.

30.6 Interrupts

TABLE 30-5: EC INTERRUPTS

Source	Description
ADC_Single_Int	Interrupt signal from ADC controller to EC for Single-Sample ADC conversion.
ADC_Repeat_Int	Interrupt signal from ADC controller to EC for Repeated ADC conversion.

30.7 Low Power Modes

The ADC may be put into a low power state by the chip's Power, Clocks, and Reset (PCR) circuitry.

The ADC is designed to conserve power when it is either sleeping or disabled. It is disabled via the **ACTIVATE** Bit and sleeps when the ADC_SLEEP_EN signal is asserted. The sleeping state only controls clocking in the ADC and does not power down the analog circuitry. For lowest power consumption, the ADC **ACTIVATE** bit must be set to '0.'

30.8 Description

FIGURE 30-2: ADC BLOCK DIAGRAM

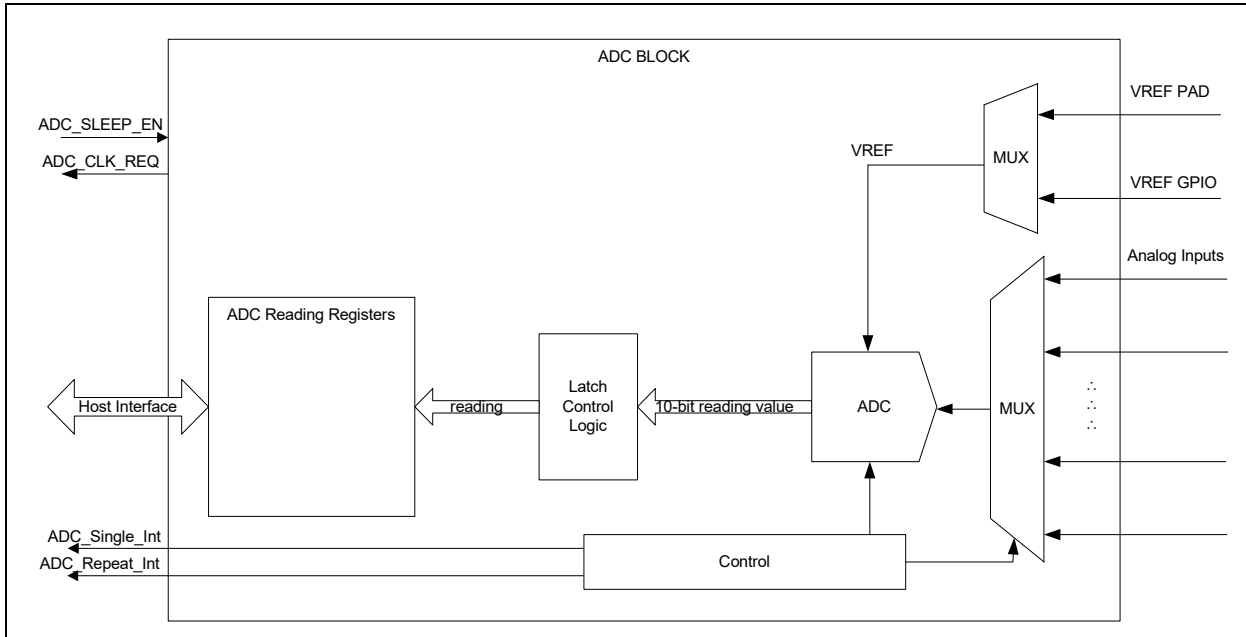

The MEC1725 features a sixteen channel successive approximation Analog to Digital Converter. The ADC architecture features excellent linearity and converts analog signals to 12 bit words. Conversion takes approximately 900 nanoseconds per 12-bit word. The sixteen channels are implemented with a single high speed ADC fed by a sixteen input analog multiplexer. The multiplexer cycles through the sixteen voltage channels, starting with the lowest-numbered channel and proceeding to the highest-number channel, selecting only those channels that are programmed to be active.

The input range on the voltage channels spans from 0V to the voltage reference. With a voltage reference of 3.3V, this provides resolutions of 3.2mV. The range can easily be extended with the aid of resistor dividers. The accuracy of any voltage reading depends on the accuracy and stability of the voltage reference input.

- Note:** The ADC pins are 3.3V tolerant.
- Note:** Transitions on ADC GPIOs are not permitted when Analog to Digital Converter readings are being taken.
- Note:** If GPIO and VREF2_ADC pins are shared and used as a GPIO, noise can be injected into the ADC. Hence care should be taken in system design to make sure GPIOs doesn't switch when ADC is active.

The ADC conversion cycle starts either when the **START_SINGLE** bit in the ADC is set to 1 or when the ADC Repeat Timer counts down to 0. When the **START_SINGLE** is set to 1 the conversion cycle converts channels enabled by configuration bits in the **ADC Single Register**. When the Repeat Timer counts down to 0 the conversion cycle converts channels enabled by configuration bits in the **ADC Repeat Register**. When both the **START_SINGLE** bit and the Repeat Timer request conversions the **START_SINGLE** conversion is completed first.

Conversions always start with the lowest-numbered enabled channel and proceed to the highest-numbered enabled channel.

If software repeatedly sets Start_Single to 1 at a rate faster than the Repeat Timer count down interval, the conversion cycle defined by the ADC Repeat Register will not be executed.

30.8.1 REPEAT MODE

- Repeat Mode will start a conversion cycle of all ADC channels enabled by bits **RPT_EN** in the **ADC Repeat Register**. The conversion cycle will begin after a delay determined by **WARM_UP_DELAY** in **SAR ADC Control Register** and **START_DELAY** in the **ADC Delay Register**. Every channel that is enabled will be converted in 500ns for

12 bit mode and 416.6ns for 10bit mode, for 24MHz internal reference clock. The conversion time formula is **Resolution * Sampling clock time period**. This is the actual time between sampling of start of conversion and assertion of end of conversion excluding those two cycles. This does not include Warm Up delay, Startup delay, VREF switching delay and Charge delays which are user configurable.

- The conversion is followed by delay for VREF switching, if applicable, channel switching and charge delay.
- After all channels enabled by [RPT_EN](#) are complete, [REPEAT_DONE_STATUS](#) will be set to 1. The firmware will have to clear the [REPEAT_DONE_STATUS](#) bit.
- As long as [START_REPEAT](#) is 1 the ADC will repeatedly begin conversion cycles with a period defined by [REPEAT_DELAY](#).
- If the delay period expires and a conversion cycle is already in progress because [START_SINGLE](#) was written with a 1, the cycle in progress will complete, followed immediately by a conversion cycle using [RPT_EN](#) to control the channel conversions.

30.8.2 SINGLE MODE

- The Single Mode conversion cycle will begin after [WARM_UP_DELAY](#) time. After all channels enabled by [SINGLE_EN](#) are complete, [SINGLE_DONE_STATUS](#) will be set to 1. The firmware will have to clear the [SINGLE_DONE_STATUS](#) bit.
- If [START_SINGLE](#) is written with a 1, while a conversion cycle is in progress because [START_REPEAT](#) is set, the current repeat conversion cycle will complete, followed immediately by a conversion cycle using [SINGLE_EN](#) to control the channel conversions.

30.8.3 APPLICATION NOTES

Please refer to white paper on “Accurate Temperature measurement using Thermistor” for details on how to use ADC for better than 1 degree C temperature measurement accuracy. Refer to [FIGURE 30-3: ADC Reference Voltage Connection on page 416](#) for details of ADC reference voltage usage.

Note: ADC inputs require at least a 0.1 uF capacitor to filter glitches.

- Note 1:** It is recommended to use ADC sampling clock of 24MHz
- 2:** ADC sampling clock should not be configured to less than 3MHz
 - 3:** Repeat delay is dependent on the input impedance and sampling rate and will have to be tuned accordingly
 - 4:** ADC inputs require 0.1uF capacitors to filter glitches
 - 5:** Resistors used in the ADC inputs should be 1% Tolerance resistors

FIGURE 30-3: ADC REFERENCE VOLTAGE CONNECTION

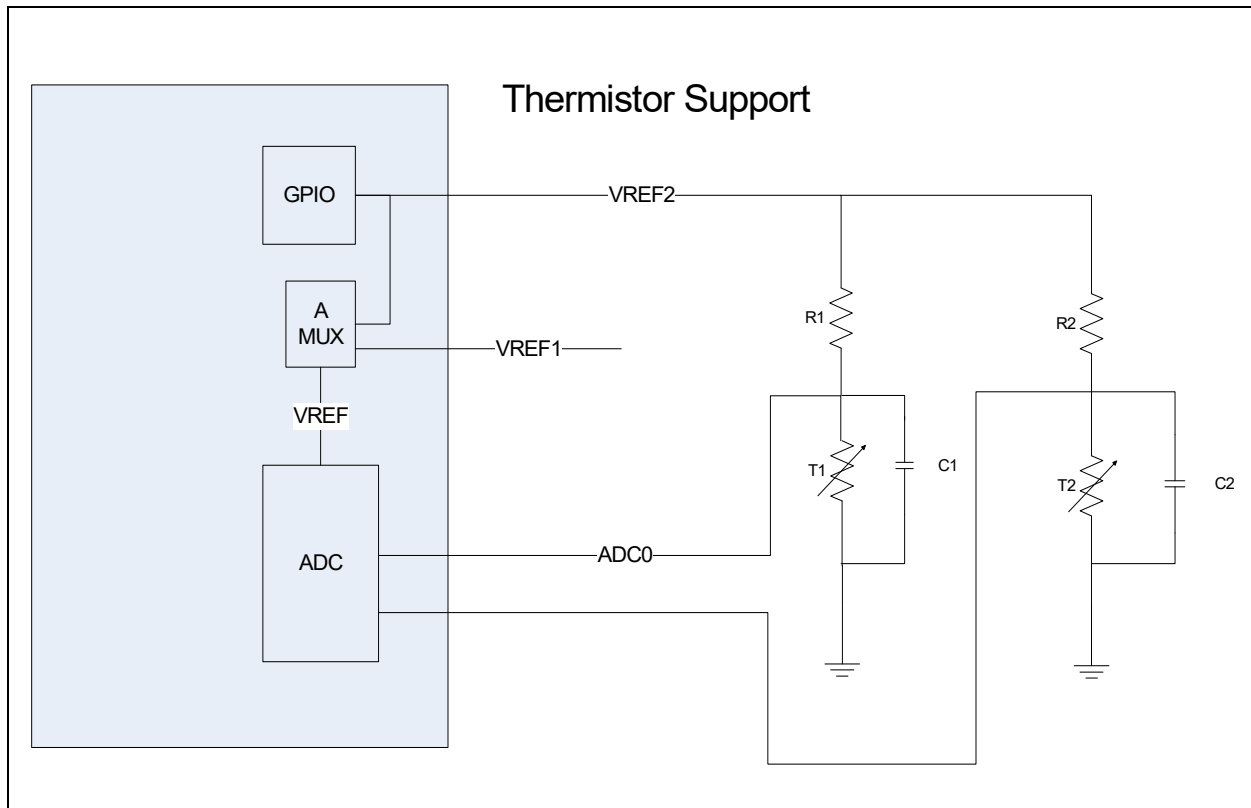

30.9 EC Registers

Registers for this block are shown in the following summary table. Addresses for each register are determined by adding the offset to the Base Address for each instance of the [Analog to Digital Converter](#) Block in the Block Overview and Base Address Table in [Section 3.0, "Device Inventory"](#).

TABLE 30-6: REGISTER SUMMARY

Offset	Register Name
00h	ADC Control Register
04h	ADC Delay Register
08h	ADC Status Register
0Ch	ADC Single Register
10h	ADC Repeat Register
14h	ADC Channel Reading Registers 0
18h	ADC Channel Reading Registers 1
1Ch	ADC Channel Reading Registers 2
20h	ADC Channel Reading Registers 3
24h	ADC Channel Reading Registers 4
28h	ADC Channel Reading Registers 5
2Ch	ADC Channel Reading Registers 6
30h	ADC Channel Reading Registers 7

TABLE 30-6: REGISTER SUMMARY

Offset	Register Name
34h	ADC Channel Reading Registers 8
38h	ADC Channel Reading Registers 9
3Ch	ADC Channel Reading Registers 10
40h	ADC Channel Reading Registers 11
44h	ADC Channel Reading Registers 12
48h	ADC Channel Reading Registers 13
4Ch	ADC Channel Reading Registers 14
50h	ADC Channel Reading Registers 15
7Ch	ADC Configuration Register
80h	VREF Channel Register
84h	VREF Control Register
88h	SAR ADC Control Register

30.9.1 ADC CONTROL REGISTER

The [ADC Control Register](#) is used to control the behavior of the Analog to Digital Converter.

Offset	00h			
Bits	Description	Type	Default	Reset Event
31:8	Reserved	RES	-	-
7	<p>SINGLE_DONE_STATUS</p> <p>This bit is cleared when it is written with a 1. Writing a 0 to this bit has no effect. This bit can be used to generate an EC interrupt.</p> <p>1= ADC single-sample conversion is completed. This bit is set to 1 when conversion completes for all enabled channels in the single conversion cycle 0= ADC single-sample conversion is not complete. This bit is cleared whenever the software writes a 1b to this bit.</p> <p>Note: Only firmware is able to clear SINGLE_DONE_STATUS and REPEAT_DONE_STATUS status bits by writing a 1 to these bits, even when multiple repeat_done or single_done events occurs before firmware services the interrupt.</p> <p>Note: This bit is not self clearing bit.</p>	R/WC	0h	RESET_SYS

MEC1725

Offset	00h			
Bits	Description	Type	Default	Reset Event
6	<p>REPEAT_DONE_STATUS</p> <p>This bit is cleared when it is written with a 1. Writing a 0 to this bit has no effect.</p> <p>This bit can be used to generate an EC interrupt.</p> <p>1= ADC repeat-sample conversion is completed. This bit is set to 1 when all enabled channels in a repeating conversion cycle complete</p> <p>0= ADC repeat-sample conversion is not complete. This bit is cleared whenever the software writes to this bit to clear it.</p> <p>Note: Only firmware is able to clear SINGLE_DONE_STATUS and REPEAT_DONE_STATUS status bits by writing a 1 to these bits, even when multiple repeat_done or single_done events occurs before firmware services the interrupt.</p> <p>Note: This bit is not self clearing bit.</p>	R/WC	0h	RESET_SYS
5	Reserved	RES	-	-
4	<p>SOFT_RESET</p> <p>1=writing one causes a reset of the ADC block hardware (not the registers)</p> <p>0=writing zero takes the ADC block out of reset</p>	R/W	0h	RESET_SYS
3	<p>POWER_SAVER_DIS</p> <p>1=Power saving feature is disabled</p> <p>Note: 0=Power saving feature is enabled. The Analog to Digital Converter controller powers down the ADC between conversion sequences.</p>	R/W	0h	RESET_SYS
2	<p>START_REPEAT</p> <p>1=The ADC Repeat Mode is enabled. This setting will start a conversion cycle of all ADC channels enabled by bits RPT_EN in the ADC Repeat Register.</p> <p>0=The ADC Repeat Mode is disabled. Note: This setting will not terminate any conversion cycle in process, but will clear the Repeat Timer and inhibit any further periodic conversions.</p>	R/W	0h	RESET_SYS
1	<p>START_SINGLE</p> <p>1=The ADC Single Mode is enabled. This setting starts a single conversion cycle of all ADC channels enabled by bits SINGLE_EN in the ADC Single Register.</p> <p>0=The ADC Single Mode is disabled.</p> <p>This bit is self-clearing</p>	R/W	0h	RESET_SYS

Offset	00h			
Bits	Description	Type	Default	Reset Event
0	<p>ACTIVATE</p> <p>1=ADC block is enabled for operation. START_SINGLE or START_REPEAT can begin data conversions by the ADC. Note: A reset pulse is sent to the ADC core when this bit changes from 0 to 1.</p> <p>0=The ADC is disabled and placed in its lowest power state. Note: Any conversion cycle in process will complete before the block is shut down, so that the reading registers will contain valid data but no new conversion cycles will begin.</p>	R/W	0h	RESET_SYS

30.9.2 ADC DELAY REGISTER

The ADC Delay register determines the delay from setting [START_REPEAT](#) in the [ADC Control Register](#) and the start of a conversion cycle. This register also controls the interval between conversion cycles in repeat mode.

Offset	04h			
Bits	Description	Type	Default	Reset Event
31:16	<p>REPEAT_DELAY</p> <p>This field determines the interval between conversion cycles when START_REPEAT is 1. The delay is in units of 40μs. A value of 0 means no delay between conversion cycles, and a value of 0xFFFF means a delay of 2.6 seconds.</p> <p>This field has no effect when START_SINGLE is written with a 1.</p> <p>Note: The REPEAT_DELAY is the delay before the start of each successive repeat cycle (not the first cycle. START_DELAY will be used for the first cycle) when the ADC is in low power state and the only after this delay the enable to the actual ADC block is asserted.</p>	R/W	0000h	RESET_SYS
15:0	<p>START_DELAY</p> <p>This field determines the starting delay before a conversion cycle is begun when START_REPEAT is written with a 1. The delay is in units of 40μs. A value of 0 means no delay before the start of a conversion cycle, and a value of 0xFFFF means a delay of 2.6 seconds.</p> <p>This field has no effect when START_SINGLE is written with a 1.</p> <p>Note: The START_DELAY is the delay before the start of new repeat cycle when the ADC is disabled and only after this delay the enable to the actual ADC core is asserted.</p>	R/W	0000h	RESET_SYS

MEC1725

30.9.3 ADC STATUS REGISTER

The [ADC Status Register](#) indicates whether the ADC has completed a conversion cycle.

Offset	08h			
Bits	Description	Type	Default	Reset Event
31:16	Reserved	RES	-	-
15:0	<p>ADC_CH_STATUS</p> <p>All bits are cleared by being written with a '1'.</p> <p>1=conversion of the corresponding ADC channel is complete 0=conversion of the corresponding ADC channel is not complete</p> <p>For enabled single cycles, the SINGLE_DONE_STATUS bit in the ADC Control Register is also set after all enabled channel conversion are done; for enabled repeat cycles, the REPEAT_DONE_STATUS in the ADC Control Register is also set after all enabled channel conversion are done.</p>	R/WC	00h	RESET_SYS

30.9.4 ADC SINGLE REGISTER

The [ADC Single Register](#) is used to control which ADC channel is captured during a Single-Sample conversion cycle initiated by the [START_SINGLE](#) bit in the [ADC Control Register](#).

Note: Do not change the bits in this register in the middle of a conversion cycle to insure proper operation.

Offset	0Ch			
Bits	Description	Type	Default	Reset Event
31:16	Reserved	RES	-	-
15:0	<p>SINGLE_EN</p> <p>Each bit in this field enables the corresponding ADC channel when a single cycle of conversions is started when the START_SINGLE bit in the ADC Control Register is written with a 1.</p> <p>1=single cycle conversions for this channel are enabled 0=single cycle conversions for this channel are disabled</p>	R/W	0h	RESET_SYS

30.9.5 ADC REPEAT REGISTER

The [ADC Repeat Register](#) is used to control which ADC channels are captured during a repeat conversion cycle initiated by the [START_REPEAT](#) bit in the [ADC Control Register](#).

Offset	10h			
Bits	Description	Type	Default	Reset Event
31:16	Reserved	RES	-	-
15:0	<p>RPT_EN</p> <p>Each bit in this field enables the corresponding ADC channel for each pass of the Repeated ADC Conversion that is controlled by bit START_REPEAT in the ADC Control Register.</p> <p>1=repeat conversions for this channel are enabled 0=repeat conversions for this channel are disabled</p>	R/W	00h	RESET_SYS

30.9.6 ADC CHANNEL READING REGISTERS

All ADC channels return their results into a 32-bit reading register. In each case the low 12 bits of the reading register return the result of the Analog to Digital conversion and the upper 22/20 bits return 0. [Table 30-6, "Register Summary"](#) shows the addresses of all the reading registers. For 10 bit ADC mode, [SHIFT_DATA](#) determines if the ADC reading is at bits [11:2] or [9:0]. For 12 bit ADC mode, [SHIFT_DATA](#) field has no impact on output and all lower 12 bits are valid.

Note: The [ADC Channel Reading Registers](#) access require single 16, or 32 bit reads; i.e., two 8 bit reads will not provide data coherency.

30.9.7 ADC CONFIGURATION REGISTER

Offset	7Ch			
Bits	Description	Type	Default	Reset Event
31:16	TEST	R	-	-
15:8	ADC_CLK_HIGH_TIME High Time Count ADC Clock: Programmable from 1 to 255. 0 is not used. Note: The High Time Count must be programmed to be equal to the Low Time Count (must be programmed to 50% duty cycle).	R/W	01h	RESET_SYS
7:0	ADC_CLK_LOW_TIME Low Time Count ADC Clock: Programmable from 1 to 255. 0 is not used. Note: The High Time Count must be programmed to be equal to the Low Time Count (must be programmed to 50% duty cycle).	R/W	01h	RESET_SYS

30.9.8 VREF CHANNEL REGISTER

Offset	80h			
Bits	Description	Type	Default	Reset Event
31:30	VREF Select for Channel 15 00 = VREF Pad 01 = VREF GPIO 10 = Reserved 11 = Reserved	R/W	0h	RESET_SYS
29:28	VREF Select for Channel 14 00 = VREF Pad 01 = VREF GPIO 10 = Reserved 11 = Reserved	R/W	0h	RESET_SYS
27:26	VREF Select for Channel 13 00 = VREF Pad 01 = VREF GPIO 10 = Reserved 11 = Reserved	R/W	0h	RESET_SYS

MEC1725

Offset	80h	Bits	Description	Type	Default	Reset Event
25:24	VREF Select for Channel 12 00 = VREF Pad 01 = VREF GPIO 10 = Reserved 11 = Reserved	R/W	0h	RESET_SYS_		
23:22	VREF Select for Channel 11 00 = VREF Pad 01 = VREF GPIO 10 = Reserved 11 = Reserved	R/W	0h	RESET_SYS_		
21:20	VREF Select for Channel 10 00 = VREF Pad 01 = VREF GPIO 10 = Reserved 11 = Reserved	R/W	0h	RESET_SYS_		
19:18	VREF Select for Channel 9 00 = VREF Pad 01 = VREF GPIO 10 = Reserved 11 = Reserved	R/W	0h	RESET_SYS_		
17:16	VREF Select for Channel 8 00 = VREF Pad 01 = VREF GPIO 10 = Reserved 11 = Reserved	R/W	0h	RESET_SYS_		
15:14	VREF Select for Channel 7 00 = VREF Pad 01 = VREF GPIO 10 = Reserved 11 = Reserved	R/W	0h	RESET_SYS_		
13:12	VREF Select for Channel 6 00 = VREF Pad 01 = VREF GPIO 10 = Reserved 11 = Reserved	R/W	0h	RESET_SYS_		
11:10	VREF Select for Channel 5 00 = VREF Pad 01 = VREF GPIO 10 = Reserved 11 = Reserved	R/W	0h	RESET_SYS_		
9:8	VREF Select for Channel 4 00 = VREF Pad 01 = VREF GPIO 10 = Reserved 11 = Reserved	R/W	0h	RESET_SYS_		
7:6	VREF Select for Channel 3 00 = VREF Pad 01 = VREF GPIO 10 = Reserved 11 = Reserved	R/W	0h	RESET_SYS_		

Offset	80h			
Bits	Description	Type	Default	Reset Event
5:4	VREF Select for Channel 2 00 = VREF Pad 01 = VREF GPIO 10 = Reserved 11 = Reserved	R/W	0h	RESET_SYS_
3:2	VREF Select for Channel 1 00 = VREF Pad 01 = VREF GPIO 10 = Reserved 11 = Reserved	R/W	0h	RESET_SYS_
1:0	VREF Select for Channel 0 00 = VREF Pad 01 = VREF GPIO 10 = Reserved 11 = Reserved	R/W	0h	RESET_SYS_

30.9.9 VREF CONTROL REGISTER

Offset	84h			
Bits	Description	Type	Default	Reset Event
31:30	VREF Select Status These bits show the VREF selected at this time of reading the register.	R	0h	RESET_SYS_
29	VREF_PAD_CTL This is the VREF Pad Control 0 = Leave unused pad floating 1 = Drive unused pad low	R/W	0h	RESET_SYS_
28:16	VREF Switch Delay This is the time delay required to switch VREF selects	R/W	0h	RESET_SYS_
15:0	VREF Charge Delay This is the time delay required to charge the external VREF capacitor	R/W	0h	RESET_SYS_

30.9.10 SAR ADC CONTROL REGISTER

Offset	88h			
Bits	Description	Type	Default	Reset Event
31:17	Reserved	RES	-	-
16:7	WARM_UP_DELAY This is the warm up time delay required for ADC. The delay is in terms of number of ADC clock cycles.	R/W	202h	RESET_SYS_
6-4	Reserved	RES	-	-

MEC1725

Offset	88h			
Bits	Description	Type	Default	Reset Event
3	SHIFT_DATA Right justify ADC output data for 10 bit ADC mode. This field has no effect in the 12 bit ADC mode. 0 = ADC_DOUT will be on bits [11:2] of ADC Channel Reading register for 10 bit ADC mode and lower bits [1:0] are 0 1 = ADC_DOUT will be on bits [9:0] of ADC Channel Reading register for 10 bit ADC mode as bits are shifted right following resolution selection.	R/W	0h	RESET_SYS_
2:1	SEL_RES These bits define the SAR ADC resolution 00b = Reserved 01b = Reserved 10b = 10 bit resolution 11b = 12 bit resolution	R/W	3h	RESET_SYS_
0	SELDIFF This bit define the single ended / differential mode of ADC operation 0 = ADC is enabled for single ended input operation 1 = ADC is enabled for differential mode input operation	R/W	0h	RESET_SYS_

31.0 RC IDENTIFICATION DETECTION (RC_ID)

31.1 Introduction

The Resistor/Capacitor Identification Detection (RC_ID) interface provides a single pin interface which can discriminate a number of quantized RC constants.

31.2 References

No references have been cited for this feature.

31.3 Terminology

There is no terminology defined for this section.

31.4 Interface

This block is designed to be accessed externally via the pin interface and internally via a registered host interface.

FIGURE 31-1: I/O DIAGRAM OF BLOCK

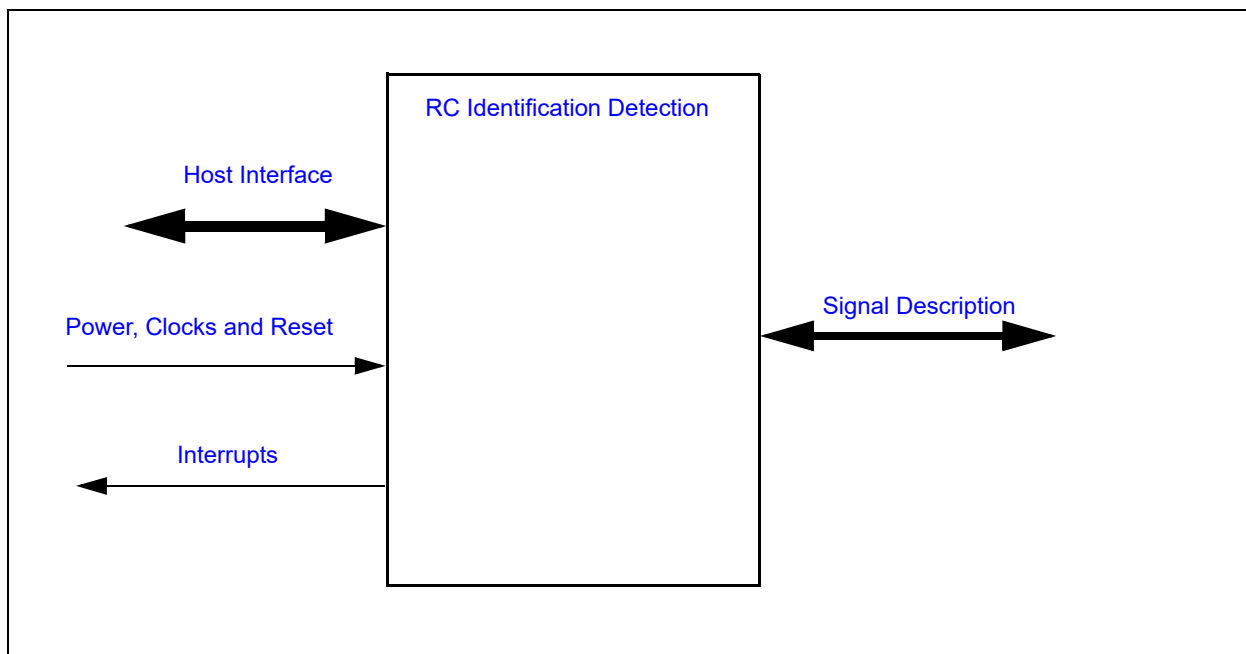

31.5 Signal Description

Name	Direction	Description
RC_ID	Input	Analog input used for measuring an external Resistor-Capacitor delay.

31.6 Host Interface

The registers defined for this block are accessible by the various hosts as indicated in [Section 31.12, "EC Registers"](#).

MEC1725

31.7 Power, Clocks and Reset

This section defines the Power, Clock, and Reset parameters of the block.

31.7.1 POWER DOMAINS

Name	Description
VTR_CORE	The logic and registers implemented in this block are powered by this power well.

31.7.2 CLOCK INPUTS

Name	Description
48MHz	The main clock domain, used to generate the time base that measures the RC delay.

31.7.3 RESETS

Name	Description
RESET_SYS	This signal resets all the registers and logic in this block to their default state.

31.8 Interrupts

This section defines the Interrupt Sources generated from this block.

Source	Description
RCID	This internal signal is generated when the DONE bit in the RC_ID Control Register is set to '1'.

31.9 Low Power Modes

This block may be put into a low power state by the chip's Power, Clocks, and Reset (PCR) circuitry. If a measurement has been started, the block will continue to assert its clock_req output until the measurement completes.

31.10 Description

Note: The RC_ID block only operates on 3.3V. The VTR pin associated with RC_ID signals must be connected to a 3.3V supply. If the VTR pin is supplied with 1.8V, the RC_ID logic will not function correctly.

The Resistor/Capacitor Identification Detection (RC_ID) interface provides a single pin interface which can discriminate a number of quantized RC constants. The judicious selection of RC values can provide a low cost means for system element configuration identification. The RC_ID I/O pin measures the charge/discharge time for an RC circuit connected to the pin as shown in Figure 31-2.

FIGURE 31-2: BLOCK DIAGRAM OF RC Identification Detection (RC_ID)

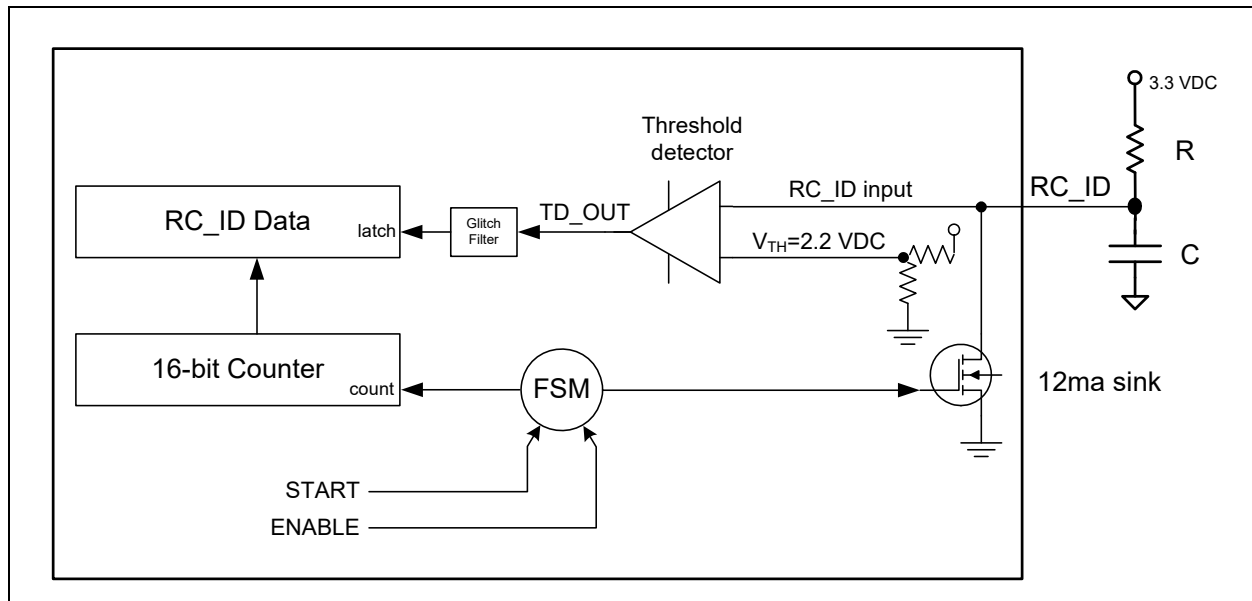

The RC_ID interface determines the selected RC delay by measuring the rise time on the RC_ID pin that is attached to the RC circuit, as shown in the above figure. The measurement is performed by first discharging the external capacitor for a fixed period of time, set by an internal 16-bit counter running at a configurable time base, and then letting the capacitor charge again, using the same counter and time base to count how many clock ticks are required until the voltage on the capacitor exceeds 2.2V. A glitch filter, consisting of three ticks of the 48MHz main oscillator, smooths the threshold detection.

By fixing the capacitor value and varying the resistor value, up to eight discrete values can be determined based on the final count. Section 31.11, "Time Constants" shows a range of possible R and C values that can be used to create eight ID values.

Measurement requires five phases:

1. **Reset.** The two control bits (**ENABLE** and **START**) and the three status bits (**TC**, **DONE** and **CY_ER**) in the **RC_ID Control Register** are all '0'. The RD_IC pin is tri-stated and the block is in its lowest power state. In order to enter the Reset state, firmware must write the **ENABLE**, **START** and **CLOCK_SET** fields to '0' simultaneously or unpredictable results may occur.
2. **Armed.** Firmware enables the transition to this state by setting the **ENABLE** bit to '1' and the **CLOCK_SET** field to the desired time base. The **START** must remain at '0'. All three fields must be set with one write to the **RC_ID Control Register**. In this state the RC_ID clock is enabled and the 16-bit counter is armed. Firmware must wait a minimum of 300µS in the Armed phase before starting the Discharged phase.
3. **Discharged.** Firmware initiates the transition to the Discharged state by setting the **ENABLE** bit to '1', the **START** bit to '1' and the **CLOCK_SET** field to the desired clock rate, in a single write to the **RC_ID Control Register**. The RC_ID pin is discharged while the 16-bit counter counts from 0000h to FFFFh at the configured time base. When the counter reaches FFFFh the **TC** status bit is set to '1'. If at the end of the Discharged state the RC_ID pin remains above the 2.2V threshold, the **CY_ER** bit is set to '1', since the measurement will not be valid.
4. **Charged.** The RC_ID state machine automatically transitions to this state after the 16-bit counter reaches FFFFh while in the Discharged state. The 16-bit counter starts counting up from 0000h. The counter stops counting and its value is copied into the **RC_ID Data Register** when the voltage on the pin exceeds 2.2V. If the counter reaches FFFFh and the pin voltage remains below 2.2V, the **CY_ER** bit is set to '1'.
5. **Done.** After the counter stops counting, either because the pin voltage exceeded the 2.2V threshold or the 16-bit counter reached FFFFh, the state machine transitions to this state. The **DONE** bit is set to '1' and the RC_ID interface re-enters its lowest power state. The interface will remain in the Done state until firmware explicitly initiates the Reset state.

A new measurement must be started by putting the RC_ID Interface into the "Reset" state.

MEC1725

The five phases, along with the values of the control and status bits in the Control Register at the end of each phase, are summarized in the following table and figure:

TABLE 31-1: RC ID STATE TRANSITIONS

	State	ENABLE	START	TC	DONE
1.	Reset	0	0	0	0
2.	Armed	1	0	0	0
3.	Discharged	1	1	0	0
4.	Charged	1	1	1	0
5.	Done	1	1	1	1

FIGURE 31-3: RCID STATE TRANSITIONS

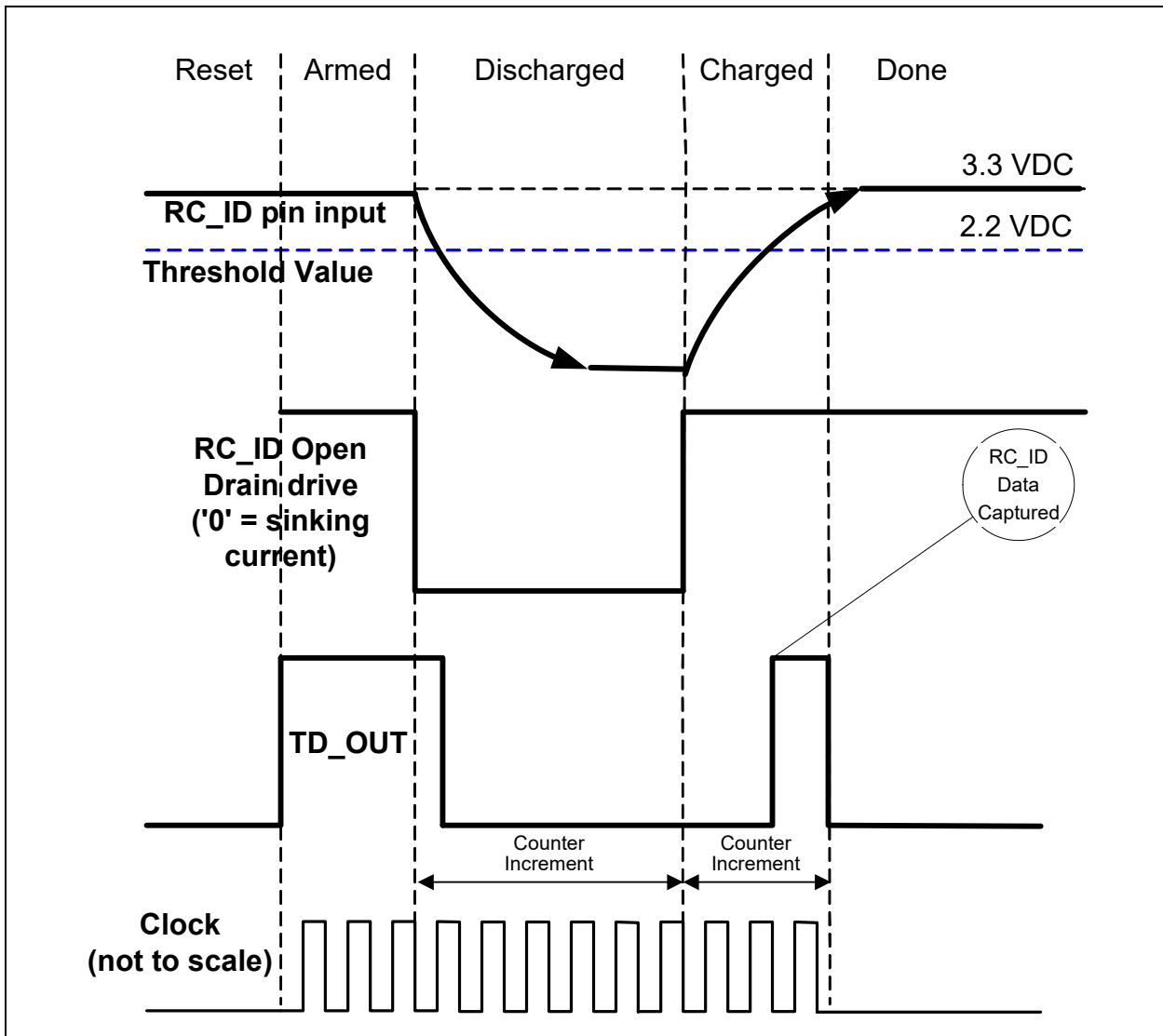

31.11 Time Constants

This section lists a set of R and C values which can be connected to the RC_ID pin. Note that risetime generally follow RC time Tau. Firmware should use the Max and Min Counts in the tables to create quantized states.

In the following tables, the `CLOCK_SET` field in the `RC_ID Control Register` is set to '0', so the time base for measuring the rise time is 48MHz, the speed of the system clock. All capacitor values are $\pm 10\%$ and all resistor values are $\pm 5\%$. Minimum and maximum count values are suggested ranges, calculated to provide reasonable margins around the nominal rise times. Rise times have been confirmed by laboratory measurements.

TABLE 31-2: SAMPLE RC VALUES, C=2200PF

R (K Ω)	Nominal Tau (μ S)	Minimum Count	Maximum Count
1	2.2	60.00	72.00
2	4.4	115.00	140.00
4.3	9.5	241.00	294.00
8.2	18.04	456.00	557.00
33	72.6	1819.00	2224.00
62	136.4	3456.00	4224.00
130	286	7470.00	9130.00
240	528	14400.00	17600.00

TABLE 31-3: SAMPLE RC VALUES, C=3000PF

R (K Ω)	Nominal Tau (μ S)	Minimum Count	Maximum Count
1	3	77.00	95.00
2	6	151.00	184.00
4.3	12.9	320.00	391.00
8.2	24.6	604.00	739.00
33	99	2439.00	2981.00
62	186	4647.00	5680.00
130	390	9990.00	12210.00
240	720	193508.00	23650.00

TABLE 31-4: SAMPLE RC VALUES, C=4700PF

R (K Ω)	Nominal Tau (μ S)	Minimum Count	Maximum Count
1	4.7	116.00	142.00
2	9.4	229.00	280.00
4.3	20.2	495.00	605.00
8.2	38.5	945.00	1160.00
33	155.1	3780.00	4650.00
62	291.4	7249.00	8859.00
130	611	15480.00	18920.00
240	1128	29880.00	36520.00

MEC1725

31.12 EC Registers

Registers for this block are shown in the following summary table. Addresses for each register are determined by adding the offset to the Base Address for each instance of the [RC Identification Detection \(RC_ID\)](#) Block in the Block Overview and Base Address Table in [Section 3.0, "Device Inventory"](#).

TABLE 31-5: REGISTER SUMMARY

Offset	Register Name
00h	RC_ID Control Register
04h	RC_ID Data Register

31.12.1 RC_ID CONTROL REGISTER

Offset	00h			
Bits	Description	Type	Default	Reset Event
31:10	Reserved	R	-	-
9:8	CLOCK_SET This field selects the frequency of the Counter circuit clock. This field must retain the same value as long as the ENABLE bit in this register is '1'. 3=6MHz 2=12MHz 1=24MHz 0=48MHz	R/W	0h	RESETSYS
7	ENABLE Clearing the bit to '0' causes the RC_ID interface to enter the Reset state, gating its clocks, clearing the status bits in this register and entering into its lowest power state. Setting this bit to '1' causes the RC_ID interface to enter the Armed phase of an RC_ID measurement. When this bit is cleared to '0', the CLOCK_SET and START fields in this register must also be cleared to '0' in the same register write.	R/W	0h	RESETSYS
6	START Setting this bit to '1' initiates the Discharged phase of an RC_ID measurement. Writes that change this bit from '0' to '1' must also write the ENABLE bit to '1', and must not change the CLOCK_SET field. A period of at least 300µS must elapse between setting the ENABLE bit to '1' and setting this bit to '1'.	R/W	0h	RESETSYS
5:3	Reserved	R	-	-

Offset	00h			
Bits	Description	Type	Default	Reset Event
2	CY_ER This bit is '1' if an RC_ID measurement encountered an error and the reading in the RC_ID Data Register is invalid. This bit is cleared to '0' when the RC_ID interface is in the Reset phase. It is set either if during the Discharged phase the RC_ID pin did not fall below the 2.2V threshold, or if in the Charged phase the RC_ID pin did not rise above the 2.2V threshold and the 16-bit counter ended its count at FFFFh.	R	0h	RESE T_SY S
1	TC This bit is cleared to '0' when the RC_ID interface is in the Reset phase, and set to '1' when the interface completes the Discharged phase of an RC_ID measurement.	R	0h	RESE T_SY S
0	DONE This bit is cleared to '0' when the RC_ID interface is in the Reset phase, and set to '1' when the interface completes an RC_ID measurement.	R	0h	RESE T_SY S

31.12.2 RC_ID DATA REGISTER

Offset	04h			
Bits	Description	Type	Default	Reset Event
31:16	Reserved	R	-	-
15:0	DATA Reads of this register provide the result of an RC_ID measurement.	R	0h	RESE T_SY S

32.0 BLINKING/BREATHING LED

32.1 Introduction

LEDs are used in computer applications to communicate internal state information to a user through a minimal interface. Typical applications will cause an LED to blink at different rates to convey different state information. For example, an LED could be full on, full off, blinking at a rate of once a second, or blinking at a rate of once every four seconds, in order to communicate four different states.

As an alternative to blinking, an LED can “breathe”, that is, oscillate between a bright state and a dim state in a continuous, or apparently continuous manner. The rate of breathing, or the level of brightness at the extremes of the oscillation period, can be used to convey state information to the user that may be more informative, or at least more novel, than traditional blinking.

The blinking/breathing hardware is implemented using a PWM. The PWM can be driven either by the [Main system clock](#) or by a [32.768 KHz clock](#) input. When driven by the [Main system clock](#), the PWM can be used as a standard 8-bit PWM in order to control a fan. When used to drive blinking or breathing LEDs, the [32.768 KHz clock](#) source is used.

Features:

- Each PWM independently configurable
- Each PWM configurable for LED blinking and breathing output
- Highly configurable breathing rate from 60ms to 1min
- Non-linear brightness curves approximated with 8 piece wise-linear segments
- All LED PWMs can be synchronized
- Each PWM configurable for 8-bit PWM support
- Multiple clock rates
- Configurable Watchdog Timer

32.2 Interface

This block is designed to drive a pin on the pin interface and to be accessed internally via a registered host interface.

FIGURE 32-1: I/O DIAGRAM OF BLOCK

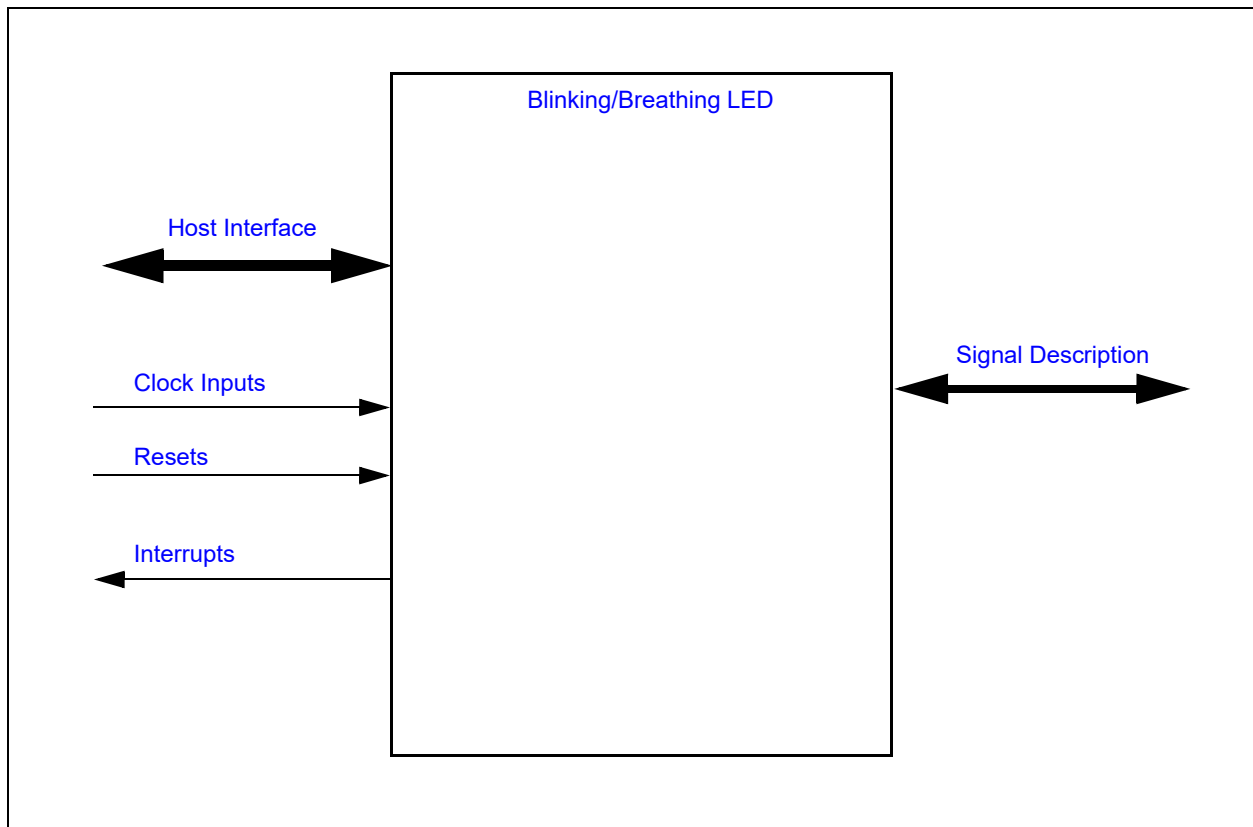

32.3 Signal Description

Name	Direction	Description
LEDx	Output	<p>PWM LED Output^a</p> <p>By default, the LEDx pin is configured to be active high: when the LED is configured to be fully on, the pin is driving high. When the LED is configured to be fully off, the pin is low. If firmware requires the Blinking/Breathing PWM to be active low, the Polarity bit in the GPIO Pin Control Register associated with the LED can be set to 1, which inverts the output polarity.</p>

a. Refer to the [Table 1-1, "MEC1725 Feature List"](#) table to know the number of LED pins available in the chip.

32.4 Host Interface

The blinking/breathing PWM block is accessed by the various hosts as indicated in [Section 3.2, "Block Overview and Base Addresses"](#).

32.5 Power, Clocks and Reset

This section defines the Power, Clock, and Reset parameters of the block.

MEC1725

32.5.1 POWER DOMAINS

Name	Description
VTR_CORE	Main power. The source of main power for the device is system dependent.

32.5.2 CLOCK INPUTS

Name	Description
32KHz Core	32.768 KHz clock
48MHz	Main system clock

32.5.3 RESETS

Name	Description
RESET_SYS	This reset signal resets all the logic and register in this block.
RESET	This reset signal, resets the PWM registers to their default values.

32.6 Interrupts

Each PWM can generate an interrupt. The interrupt is asserted for one [Main system clock](#) period whenever the PWM WDT times out. The PWM WDT is described in [Section 32.8.3.1, "PWM WDT"](#).

Source	Description
PWM_WDT	PWM watchdog time out

32.7 Low Power Mode

The Blinking/Breathing LED may be put into a low power mode by the chip-level power, clocks, and reset (PCR) circuitry. The low power mode is only applicable when the Blinking/Breathing PWM is operating in the [General Purpose PWM](#) mode. When the low speed clock mode is selected, the blinking/breathing function continues to operate, even when the [48MHz](#) is stopped. Low power mode behavior is summarized in the following table:

TABLE 32-1: LOW POWER MODE BEHAVIOR

CLOCK_SOURCE	CONTROL	Mode	Low Power Mode	Description
X	'00'b	PWM 'OFF'	Yes	32.768 KHz clock is required.
X	'01'b	Breathing	Yes	
1	'10'b	General Purpose PWM	No	Main system clock is required, even when a sleep command to the block is asserted.
0	'10'b	Blinking	Yes	32.768 KHz clock is required.
X	'11'b	PWM 'ON'	Yes	

Note: In order for the MEC1725 to enter its Heavy Sleep state, the SLEEP_ENABLE input for all Blinking/Breathing PWM instances must be asserted, even if the PWMs are configured to use the low speed clock.

32.8 Description

32.8.1 BREATHING

If an LED blinks rapidly enough, the eye will interpret the light as reduced brightness, rather than a blinking pattern. Therefore, if the blinking period is short enough, modifying the duty cycle will set the apparent brightness, rather than a blinking rate. At a blinking rate of 128Hz or greater, almost all people will perceive a continuous light source rather than an intermittent pattern.

Because making an LED appear to breathe is an aesthetic effect, the breathing mechanism must be adjustable or customers may find the breathing effect unattractive. There are several variables that can affect breathing appearance, as described below.

The following figure illustrates some of the variables in breathing:

FIGURE 32-2: BREATHING LED EXAMPLE

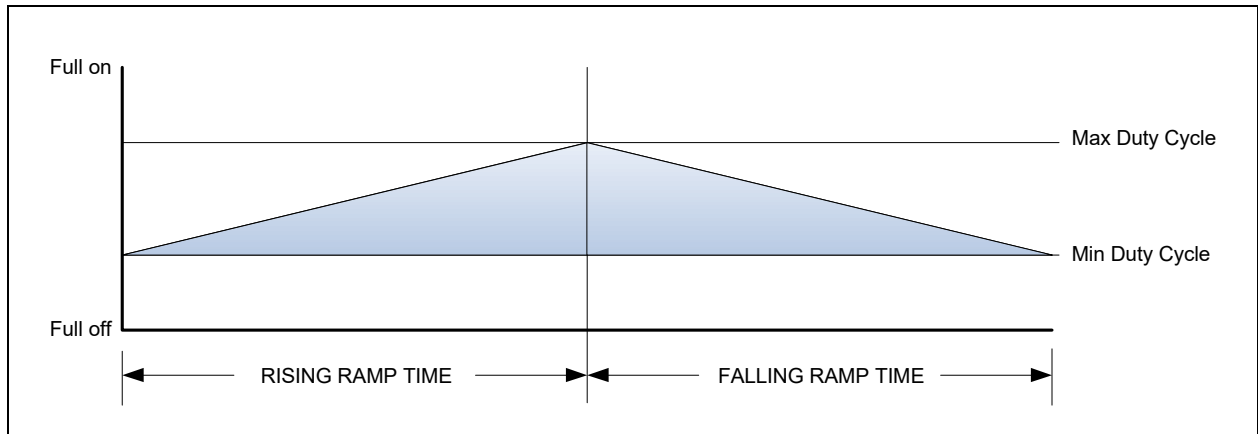

The breathing range of an LED can range between full on and full off, or in a range that falls within the full-on/full-off range, as shown in this figure. The ramp time can be different in different applications. For example, if the ramp time was 1 second, the LED would appear to breathe quickly. A time of 2 seconds would make the LED appear to breathe more leisurely.

The breathing pattern can be clipped, as shown in the following figure, so that the breathing effect appears to pause at its maximum and minimum brightnesses:

FIGURE 32-3: CLIPPING EXAMPLE

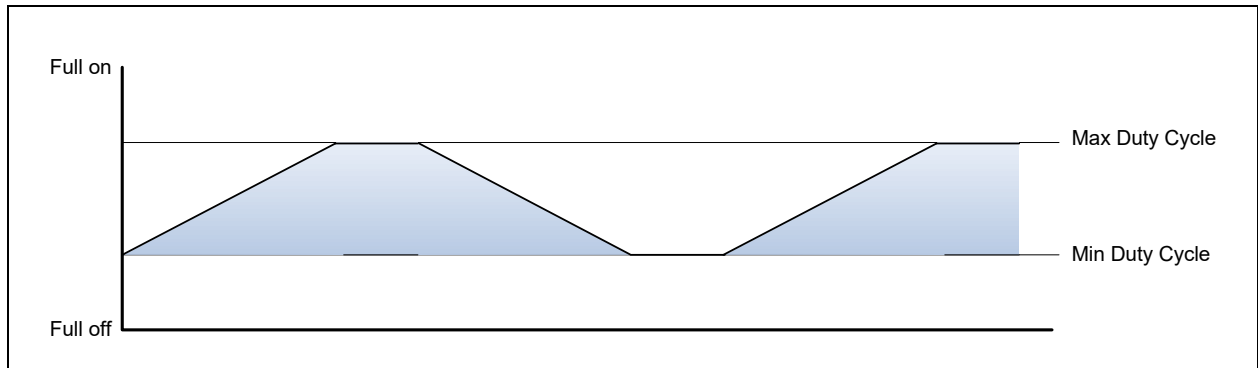

The clipping periods at the two extremes can be adjusted independently, so that for example an LED can appear to breathe (with a short delay at maximum brightness) followed by a longer “resting” period (with a long delay at minimum brightness).

MEC1725

The brightness can also be changed in a non-linear fashion, as shown in the following figure:

FIGURE 32-4: EXAMPLE OF A SEGMENTED CURVE

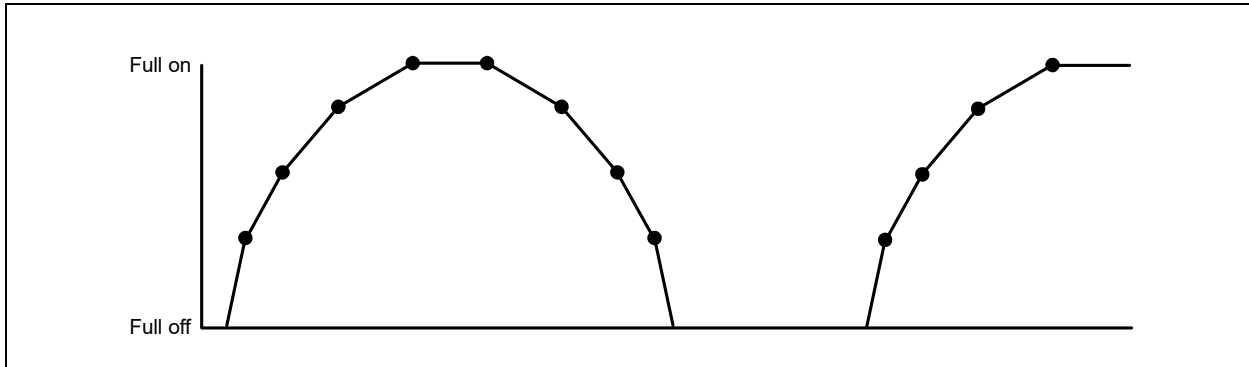

In this figure, the rise and fall curves are implemented in 4 linear segments and the rise and fall periods are symmetric.

The breathing mode uses the [32.768 KHz clock](#) for its time base.

32.8.2 BLINKING

When configured for blinking, a subset of the hardware used in breathing is used to implement the blinking function. The PWM (an 8-bit accumulator plus an 8-bit duty cycle register) drives the LED directly. The Duty Cycle register is programmed directly by the user, and not modified further. The PWM accumulator is configured as a simple 8-bit up counter. The counter uses the [32.768 KHz clock](#), and is pre-scaled by the Delay counter, to slow the PWM down from the 128Hz provided by directly running the PWM on the [32.768 KHz clock](#).

With the pre-scaler, the blink rate of the LED could be as fast as 128Hz (which, because it is blinking faster than the eye can distinguish, would appear as a continuous level) to 0.03125Hz (that is, with a period of 7.8ms to 32 seconds). Any duty cycle from 0% (0h) to 100% (FFh) can be configured, with an 8-bit precision. An LED with a duty cycle value of 0h will be fully off, while an LED with a duty cycle value of FFh will be fully on.

In Blinking mode the PWM counter is always in 8-bit mode.

[Table 32-2, "LED Blink Configuration Examples"](#) shows some example blinking configurations:

TABLE 32-2: LED BLINK CONFIGURATION EXAMPLES

Prescale	Duty Cycle	Blink Frequency	Blink
000h	00h	128Hz	full off
000h	FFh	128Hz	full on
001h	40h	64Hz	3.9ms on, 11.5ms off
003h	80h	32Hz	15.5ms on, 15.5ms off
07Fh	20h	1Hz	125ms on, 0.875s off
0BFh	16h	0.66Hz	125ms on, 1.375s off
0FFh	10h	0.5Hz	125ms on, 1.875s off
180h	0Bh	0.33Hz	129ms on, 2.875s off
1FFh	40h	0.25Hz	1s on, 3s off

The Blinking and General Purpose PWM modes share the hardware used in the breathing mode. The Prescale value is derived from the LD field of the LED_DELAY register and the Duty Cycle is derived from the MIN field of the LED_LIMITS register.

TABLE 32-3: BLINKING MODE CALCULATIONS

Parameter	Unit	Equation
Frequency	Hz	$(32\text{KHz Core frequency}) / (\text{PRESCALE} + 1) / 256$
'H' Width	Seconds	$(1/\text{Frequency}) \times (\text{DutyCycle}/256)$
'L' Width	Seconds	$(1/\text{Frequency}) \times ((1-\text{DutyCycle})/256)$

32.8.3 GENERAL PURPOSE PWM

When used in the Blinking configuration with the [48MHz](#), the LED module can be used as a general-purpose programmable Pulse-Width Modulator with an 8-bit programmable pulse width. It can be used for fan speed control, sound volume, etc. With the [48MHz](#) source, the PWM frequency can be configured in the range shown in [Table 32-4](#).

TABLE 32-4: PWM CONFIGURATION EXAMPLES

Prescale	PWM Frequency
000h	187.5 KHz
001h	94 KHz
003h	47 KHz
006h	26.8 KHz
00Bh	15.625 KHz
07Fh	1.46 KHz
1FFh	366 Hz
FFFh	46 Hz

TABLE 32-5: GENERAL PURPOSE PWM MODE CALCULATIONS

Parameter	Unit	Equation
Frequency	Hz	$(48\text{MHz frequency}) / (\text{PRESCALE} + 1) / 256$
'H' Width	Seconds	$(1/\text{Frequency}) \times (\text{DutyCycle}/256)$
'L' Width	Seconds	$(1/\text{Frequency}) \times (256 - \text{DutyCycle})$

32.8.3.1 PWM WDT

When the PWM is configured as a general-purpose PWM (in the Blinking configuration with the [Main system clock](#)), the PWM includes a Watch Dog Timer (WDT). The WDT consists of an internal 8-bit counter and an 8-bit reload value (the field WDTLD in [LED Configuration Register](#)). The internal counter is loaded with the reset value of WDTLD (14h, or 4 seconds) on system [RESET_SYS](#) and loaded with the contents of WDTLD whenever either the [LED Configuration Register](#) register is written or the MIN byte in the [LED Limits Register](#) register is written (the MIN byte controls the duty cycle of the PWM).

Whenever the internal counter is non-zero, it is decremented by 1 for every tick of the 5 Hz clock. If the counter decrements from 1 to 0, a WDT Terminal Count causes an interrupt to be generated and reset sets the [CONTROL](#) bit in the [LED Configuration Register](#) to 3h, which forces the PWM to be full on. No other PWM registers or fields are affected.

If the 5 Hz clock halts, the watchdog timer stops decrementing but retains its value, provided the device continues to be powered. When the 5 Hz clock restarts, the watchdog counter will continue decrementing where it left off.

Setting the WDTLD bits to 0 disables the PWM WDT. Other sample values for WDTLD are:

01h = 200 ms

02h = 400 ms

03h = 600 ms

04h = 800 ms

...

14h = 4seconds

FFh = 51 seconds

32.9 Implementation

In addition to the registers described in [Section 32.10, "EC Registers"](#), the PWM is implemented using a number of components that are interconnected differently when configured for breathing operation and when configured for blinking/PWM operation.

32.9.1 BREATHING CONFIGURATION

The **PSIZE** parameter can configure the PWM to one of three modes: 8-bit, 7-bit and 6-bit. The **PERIOD CTR** counts ticks of its input clock. In 8-bit mode, it counts from 0 to 255 (that is, 256 steps), then repeats continuously. In this mode, a full cycle takes 7.8ms (128Hz). In 7-bit mode it counts from 0 to 127 (128 steps), and a full cycle takes 3.9ms (256Hz). In 6-bit mode it counts from 0 to 63 (64 steps) and a full cycle takes 1.95ms (512Hz).

The output of the LED circuit is asserted whenever the **PERIOD CTR** is less than the contents of the **DUTY CYCLE** register. The appearance of breathing is created by modifying the contents of the **DUTY CYCLE** register in a continuous manner. When the LED control is off the internal counters and registers are all reset to 0 (i.e. after a write setting the **RESET** bit in the [LED Configuration Register](#) Register.) Once enabled, the **DUTY CYCLE** register is increased by an amount determined by the **LED_STEP** register and at a rate determined by the **DELAY** counter. Once the duty cycle reaches its maximum value (determined by the field **MAX**), the duty cycle is held constant for a period determined by the field **HD**. Once the hold time is complete, the **DUTY CYCLE** register is decreased, again by an amount determined by the **LED_STEP** register and at a rate determined by the **DELAY** counter. When the duty cycle then falls at or below the minimum value (determined by the field **MIN**), the duty cycle is held constant for a period determined by the field **HD**. Once the hold time is complete, the cycle repeats, with the duty cycle oscillating between **MIN** and **MAX**.

The rising and falling ramp times as shown in [Figure 32-2, "Breathing LED Example"](#) can be either symmetric or asymmetric depending on the setting of the **SYMMETRY** bit in the [LED Configuration Register](#) Register. In Symmetric mode the rising and falling ramp rates have mirror symmetry; both rising and falling ramp rates use the same (all) 8 segments fields in each of the following registers (see [Table 32-6](#)): the [LED Update Stepsize Register](#) register and the [LED Update Interval Register](#) register. In Asymmetric mode the rising ramp rate uses 4 of the 8 segments fields and the falling ramp rate uses the remaining 4 of the 8 segments fields (see [Table 32-6](#)).

The parameters **MIN**, **MAX**, **HD**, **LD** and the 8 fields in **LED_STEP** and **LED_INT** determine the brightness range of the LED and the rate at which its brightness changes. See the descriptions of the fields in [Section 32.10, "EC Registers"](#), as well as the examples in [Section 32.9.3, "Breathing Examples"](#) for information on how to set these fields.

TABLE 32-6: SYMMETRIC BREATHING MODE REGISTER USAGE

Rising/ Falling Ramp Times in Figure 32-3, "Clipping Example"	Duty Cycle	Segment Index	Symmetric Mode Register Fields Utilized	
X	000xxxxxb	000b	STEP[0]/INT[0]	Bits[3:0]
X	001xxxxxb	001b	STEP[1]/INT[1]	Bits[7:4]
X	010xxxxxb	010b	STEP[2]/INT[2]	Bits[11:8]
X	011xxxxxb	011b	STEP[3]/INT[3]	Bits[15:12]
X	100xxxxxb	100b	STEP[4]/INT[4]	Bits[19:16]
X	101xxxxxb	101b	STEP[5]/INT[5]	Bits[23:20]
X	110xxxxxb	110b	STEP[6]/INT[6]	Bits[27:24]
X	111xxxxxb	111b	STEP[7]/INT[7]	Bits[31:28]

Note: In Symmetric Mode the Segment_Index[2:0] = Duty Cycle Bits[7:5]

TABLE 32-7: ASYMMETRIC BREATHING MODE REGISTER USAGE

Rising/ Falling Ramp Times in Figure 32-3, "Clipping Example"	Duty Cycle	Segment Index	Asymmetric Mode Register Fields Utilized	
Rising	00xxxxxb	000b	STEP[0]/INT[0]	Bits[3:0]
Rising	01xxxxxb	001b	STEP[1]/INT[1]	Bits[7:4]
Rising	10xxxxxb	010b	STEP[2]/INT[2]	Bits[11:8]

TABLE 32-7: ASYMMETRIC BREATHING MODE REGISTER USAGE (CONTINUED)

Rising/ Falling Ramp Times in Figure 32-3, "Clipping Example"	Duty Cycle	Segment Index	Asymmetric Mode Register Fields Utilized	
Rising	11xxxxxb	011b	STEP[3]/INT[3]	Bits[15:12]
falling	00xxxxxb	100b	STEP[4]/INT[4]	Bits[19:16]
falling	01xxxxxb	101b	STEP[5]/INT[5]	Bits[23:20]
falling	10xxxxxb	110b	STEP[6]/INT[6]	Bits[27:24]
falling	11xxxxxb	111b	STEP[7]/INT[7]	Bits[31:28]

Note: In Asymmetric Mode the Segment_Index[2:0] is the bit concatenation of following: Segment_Index[2] = (FALLING RAMP TIME in Figure 32-3, "Clipping Example") and Segment_Index[1:0] = Duty Cycle Bits[7:6].

32.9.2 BLINKING CONFIGURATION

The Delay counter and the PWM counter are the same as in the breathing configuration, except in this configuration they are connected differently. The Delay counter is clocked on either the 32.768 KHz clock or the Main system clock, rather than the output of the PWM. The PWM counter is clocked by the zero output of the Delay counter, which functions as a prescaler for the input clocks to the PWM. The Delay counter is reloaded from the LD field of the LED_DELAY register. When the LD field is 0 the input clock is passed directly to the PWM counter without prescaling. In Blinking/PWM mode the PWM counter is always 8-bit, and the PSIZE parameter has no effect.

The frequency of the PWM pulse waveform is determined by the formula:

$$f_{PWM} = \frac{f_{clock}}{(256 \times (LD + 1))}$$

where f_{PWM} is the frequency of the PWM, f_{clock} is the frequency of the input clock (32.768 KHz clock or Main system clock) and LD is the contents of the LD field.

Note: At a duty cycle value of 00h (in the MIN register), the LED output is fully off. At a duty cycle value of 255h, the LED output is fully on. Alternatively, In order to force the LED to be fully on, firmware can set the CONTROL field of the Configuration register to 3 (always on).

The other registers in the block do not affect the PWM or the LED output in Blinking/PWM mode.

32.9.3 BREATHING EXAMPLES

32.9.3.1 Linear LED brightness change

In this example, the brightness of the LED increases and diminishes in a linear fashion. The entire cycle takes 5 seconds. The rise time and fall time are 1.6 seconds, with a hold time at maximum brightness of 200ms and a hold time at minimum brightness of 1.6 seconds. The LED brightness varies between full off and full on. The PWM size is set to 8-bit, so the time unit for adjusting the PWM is approximately 8ms. The registers are configured as follows:

TABLE 32-8: LINEAR EXAMPLE CONFIGURATION

Field	Value							
PSIZE	8-bit							
MAX	255							
MIN	0							
HD	25 ticks (200ms)							
LD	200 ticks (1.6s)							
Duty cycle most significant bits	000b	001b	010b	011b	100b	101b	110b	1110
LED_INT	8	8	8	8	8	8	8	8
LED_STEP	10	10	10	10	10	10	10	10

FIGURE 32-5: LINEAR BRIGHTNESS CURVE EXAMPLE

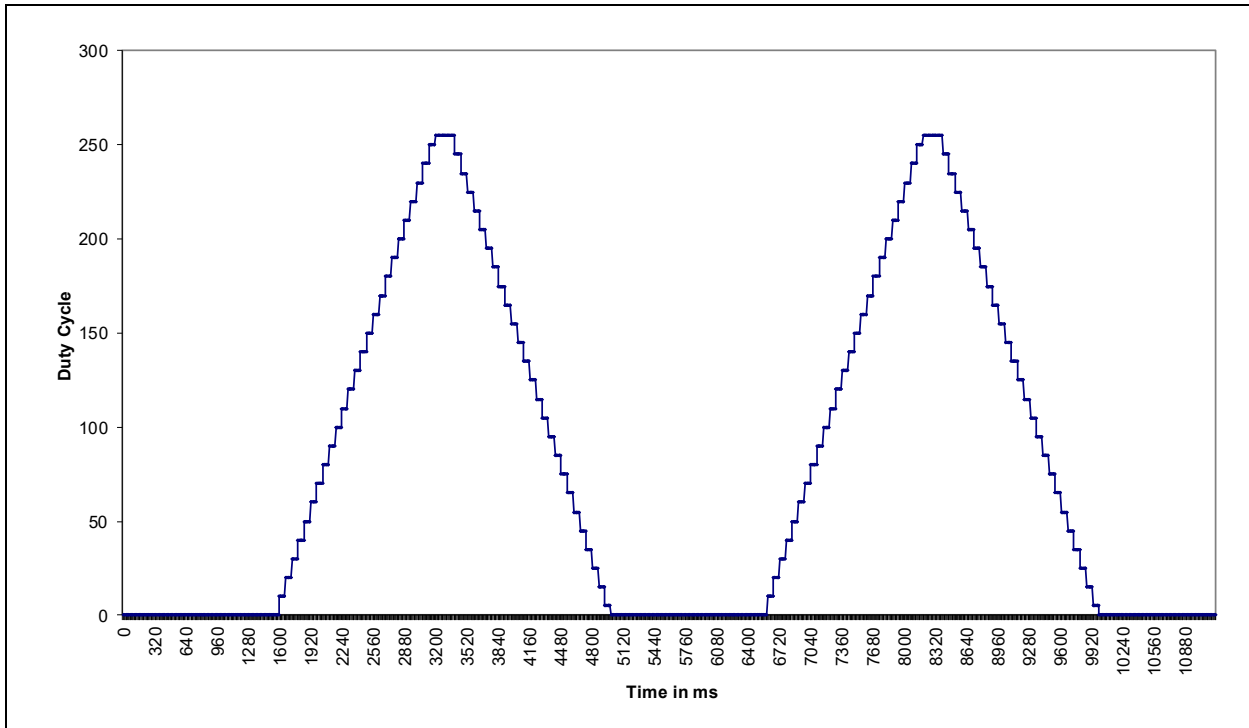

32.9.3.2 Non-linear LED brightness change

In this example, the brightness of the LED increases and diminishes in a non-linear fashion. The brightness forms a curve that is approximated by four piece wise-linear line segments. The entire cycle takes about 2.8 seconds. The rise time and fall time are about 1 second, with a hold time at maximum brightness of 320ms and a hold time at minimum brightness of 400ms. The LED brightness varies between full off and full on. The PWM size is set to 7-bit, so the time unit for adjusting the PWM is approximately 4ms. The registers are configured as follows:

TABLE 32-9: NON-LINEAR EXAMPLE CONFIGURATION

Field	Value							
PSIZE	7-bit							
MAX	255 (effectively 127)							
MIN	0							
HD	80 ticks (320ms)							
LD	100 ticks (400ms)							
Duty cycle most significant bits	000b	001b	010b	011b	100b	101b	110b	111b
LED_INT	2	3	6	6	9	9	16	16
LED_STEP	4	4	4	4	4	4	4	4

The resulting curve is shown in the following figure:

FIGURE 32-6: NON-LINEAR BRIGHTNESS CURVE EXAMPLE

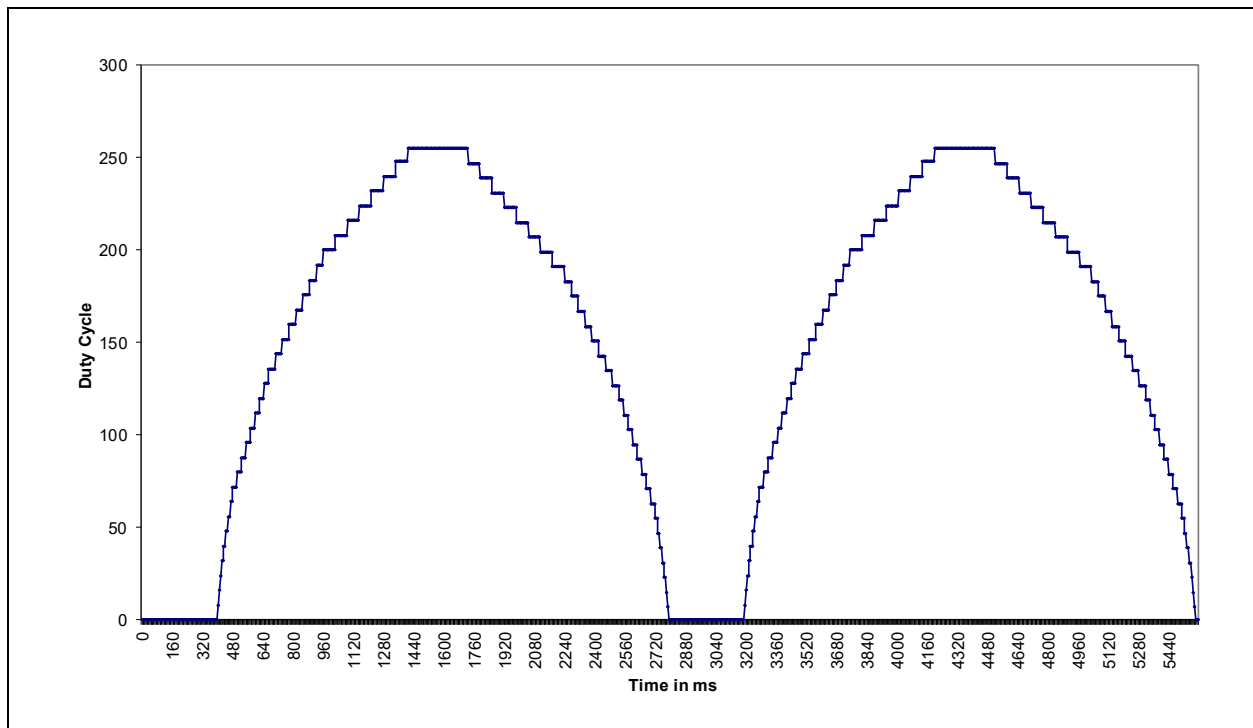

32.10 EC Registers

Registers for this block are shown in the following summary table. Addresses for each register are determined by adding the offset to the Base Address for each instance of the [Blinking/Breathing LED](#) Block in the Block Overview and Base Address Table in [Section 3.0, "Device Inventory"](#).

TABLE 32-10: REGISTER SUMMARY

Offset	Register Name
00h	LED Configuration Register
04h	LED Limits Register
08h	LED Delay Register
0Ch	LED Update Stepsize Register
10h	LED Update Interval Register
14h	LED Output Delay

In the following register definitions, a “PWM period” is defined by time the PWM counter goes from 000h to its maximum value (FFh in 8-bit mode, FEh in 7-bit mode and FCh in 6-bit mode, as defined by the PSCALE field in register LED_CFG). The end of a PWM period occurs when the PWM counter wraps from its maximum value to 0.

The registers in this block can be written 32-bits, 16-bits or 8-bits at a time. Writes to [LED Configuration Register](#) take effect immediately. Writes to [LED Limits Register](#) are held in a holding register and only take effect only at the end of a PWM period. The update takes place at the end of every period, even if only one byte of the register was updated. This means that in blink/PWM mode, software can change the duty cycle with a single 8-bit write to the MIN field in the LED_LIMIT register. Writes to [LED Delay Register](#), [LED Update Stepsize Register](#) and [LED Update Interval Register](#) also go initially into a holding register. The holding registers are copied to the operating registers at the end of a PWM period only if the Enable Update bit in the [LED Configuration Register](#) is set to 1. If LED_CFG is 0, data in the holding registers is retained but not copied to the operating registers when the PWM period expires. To change an LED breath-

MEC1725

ing configuration, software should write these three registers with the desired values and then set LED_CFG to 1. This mechanism ensures that all parameters affecting LED breathing will be updated consistently, even if the registers are only written 8 bits at a time.

32.10.1 LED CONFIGURATION REGISTER

Offset	00h			
Bits	Description	Type	Default	Reset Event
31:16	Reserved	RES	-	-
16	<p>SYMMETRY</p> <p>1=The rising and falling ramp times are in Asymmetric mode. Table 32-7, "Asymmetric Breathing Mode Register Usage" shows the application of the Stepsize and Interval registers to the four segments of rising duty cycles and the four segments of falling duty cycles.</p> <p>0=The rising and falling ramp times (as shown in Figure 32-2, "Breathing LED Example") are in Symmetric mode. Table 32-6, "Symmetric Breathing Mode Register Usage" shows the application of the Stepsize and Interval registers to the 8 segments of both rising and falling duty cycles.</p>	R/W	0b	RESET_SYS
15:8	<p>WDT_RELOAD</p> <p>The PWM Watchdog Timer counter reload value. On system reset, it defaults to 14h, which corresponds to a 4 second Watchdog timeout value.</p>	R/W	14h	RESET_SYS
7	<p>RESET</p> <p>Writes of '1' to this bit resets the PWM registers to their default values. This bit is self clearing. Writes of '0' to this bit have no effect.</p>	W	0b	RESET_SYS
6	<p>ENABLE_UPDATE</p> <p>This bit is set to 1 when written with a '1'. Writes of '0' have no effect. Hardware clears this bit to 0 when the breathing configuration registers are updated at the end of a PWM period. The current state of the bit is readable any time.</p> <p>This bit is used to enable consistent configuration of LED_DELAY, LED_STEP and LED_INT. As long as this bit is 0, data written to those three registers is retained in a holding register. When this bit is 1, data in the holding register are copied to the operating registers at the end of a PWM period. When the copy completes, hardware clears this bit to 0.</p>	R/WS	0b	RESET_SYS
5:4	<p>PWM_SIZE</p> <p>This bit controls the behavior of PWM:</p> <p>3=Reserved 2=PWM is configured as a 6-bit PWM 1=PWM is configured as a 7-bit PWM 0=PWM is configured as an 8-bit PWM</p>	R/W	0b	RESET_SYS

Offset	00h			
Bits	Description	Type	Default	Reset Event
3	<p>SYNCHRONIZE</p> <p>When this bit is '1', all counters for all LEDs are reset to their initial values. When this bit is '0' in the LED Configuration Register for all LEDs, then all counters for LEDs that are configured to blink or breathe will increment or decrement, as required.</p> <p>To synchronize blinking or breathing, the SYNCHRONIZE bit should be set for at least one LED, the control registers for each LED should be set to their required values, then the SYNCHRONIZE bits should all be cleared. If the all LEDs are set for the same blink period, they will all be synchronized.</p>	R/W	0b	RESET_SYS
2	<p>CLOCK_SOURCE</p> <p>This bit controls the base clock for the PWM. It is only valid when CNTRL is set to blink (2).</p> <p>1=Clock source is the Main system clock 0=Clock source is the 32.768 KHz clock</p>	R/W	0b	RESET_SYS
1:0	<p>CONTROL</p> <p>This bit controls the behavior of PWM:</p> <p>3=PWM is always on 2=LED blinking (standard PWM) 1=LED breathing configuration 0=PWM is always off. All internal registers and counters are reset to 0. Clocks are gated</p>	R/W	00b 11b	RESET_SYS WDT TC

32.10.2 LED LIMITS REGISTER

This register may be written at any time. Values written into the register are held in an holding register, which is transferred into the actual register at the end of a PWM period. The two byte fields may be written independently. Reads of this register return the current contents and not the value of the holding register.

Offset	04h			
Bits	Description	Type	Default	Reset Event
31:16	Reserved	RES	-	-
15:8	<p>MAXIMUM</p> <p>In breathing mode, when the current duty cycle is greater than or equal to this value the breathing apparatus holds the current duty cycle for the period specified by the field HD in register LED_DELAY, then starts decrementing the current duty cycle</p>	R/W	0h	RESET_SYS
7:0	<p>MINIMUM</p> <p>In breathing mode, when the current duty cycle is less than or equal to this value the breathing apparatus holds the current duty cycle for the period specified by the field LD in register LED_DELAY, then starts incrementing the current duty cycle</p> <p>In blinking mode, this field defines the duty cycle of the blink function.</p>	R/W	0h	RESET_SYS

MEC1725

32.10.3 LED DELAY REGISTER

This register may be written at any time. Values written into the register are held in an holding register, which is transferred into the actual register at the end of a PWM period if the Enable Update bit in the LED Configuration register is set to 1. Reads of this register return the current contents and not the value of the holding register.

Offset	08h			
Bits	Description	Type	Default	Reset Event
31:24	Reserved	RES	-	-
23:12	<p>HIGH_DELAY</p> <p>In breathing mode, the number of PWM periods to wait before updating the current duty cycle when the current duty cycle is greater than or equal to the value MAX in register LED_LIMIT.</p> <p>4095=The current duty cycle is decremented after 4096 PWM periods ... 1=The delay counter is bypassed and the current duty cycle is decremented after two PWM period 0=The delay counter is bypassed and the current duty cycle is decremented after one PWM period</p>	R/W	000h	RESET_SYS
11:0	<p>LOW_DELAY</p> <p>The number of PWM periods to wait before updating the current duty cycle when the current duty cycle is greater than or equal to the value MIN in register LED_LIMIT.</p> <p>4095=The current duty cycle is incremented after 4096 PWM periods ... 0=The delay counter is bypassed and the current duty cycle is incremented after one PWM period</p> <p>In blinking mode, this field defines the prescaler for the PWM clock</p>	R/W	000h	RESET_SYS

32.10.4 LED UPDATE STEPSIZE REGISTER

This register has eight segment fields which provide the amount the current duty cycle is adjusted at the end of every PWM period. Segment field selection is decoded based on the segment index. The segment index equation utilized depends on the **SYMMETRY** bit in the **LED Configuration Register** Register)

- In Symmetric Mode the Segment_Index[2:0] = Duty Cycle Bits[7:5]
- In Asymmetric Mode the Segment_Index[2:0] is the bit concatenation of following: Segment_Index[2] = (FALLING RAMP TIME in Figure 32-3, "Clipping Example") and Segment_Index[1:0] = Duty Cycle Bits[7:6].

This register may be written at any time. Values written into the register are held in an holding register, which is transferred into the actual register at the end of a PWM period if the Enable Update bit in the LED Configuration register is set to 1. Reads of this register return the current contents and not the value of the holding register.

In 8-bit mode, each 4-bit STEPSIZE field represents 16 possible duty cycle modifications, from 1 to 16 as the duty cycle is modified between 0 and 255:

15: Modify the duty cycle by 16

...

1: Modify the duty cycle by 2

0=Modify the duty cycle by 1

In 7-bit mode, the least significant bit of the 4-bit field is ignored, so each field represents 8 possible duty cycle modifications, from 1 to 8, as the duty cycle is modified between 0 and 127:

14, 15: Modify the duty cycle by 8

...

2, 3: Modify the duty cycle by 2

0, 1: Modify the duty cycle by 1

In 6-bit mode, the two least significant bits of the 4-bit field is ignored, so each field represents 4 possible duty cycle modifications, from 1 to 4 as the duty cycle is modified between 0 and 63:

12, 13, 14, 15: Modify the duty cycle by 4

8, 9, 10, 11: Modify the duty cycle by 3

4, 5, 6, 7: Modify the duty cycle by 2

0, 1, 2, 3: Modify the duty cycle by 1

Offset	0Ch			
Bits	Description	Type	Default	Reset Event
31:28	UPDATE_STEP7 Amount the current duty cycle is adjusted at the end of every PWM period when the segment index is equal to 111.	R/W	0h	RESET_SYS
27:24	UPDATE_STEP6 Amount the current duty cycle is adjusted at the end of every PWM period when the segment index is equal to 110.	R/W	0h	RESET_SYS
23:20	UPDATE_STEP5 Amount the current duty cycle is adjusted at the end of every PWM period when the segment index is equal to 101	R/W	0h	RESET_SYS
19:16	UPDATE_STEP4 Amount the current duty cycle is adjusted at the end of every PWM period when the segment index is equal to 100.	R/W	0h	RESET_SYS
15:12	UPDATE_STEP3 Amount the current duty cycle is adjusted at the end of every PWM period when the segment index is equal to 011.	R/W	0h	RESET_SYS
11:8	UPDATE_STEP2 Amount the current duty cycle is adjusted at the end of every PWM period when the segment index is equal to 010.	R/W	0h	RESET_SYS
7:4	UPDATE_STEP1 Amount the current duty cycle is adjusted at the end of every PWM period when the segment index is equal to 001.	R/W	0h	RESET_SYS
3:0	UPDATE_STEP0 Amount the current duty cycle is adjusted at the end of every PWM period when the segment index is equal to 000.	R/W	0h	RESET_SYS

32.10.5 LED UPDATE INTERVAL REGISTER

This register has eight segment fields which provide the number of PWM periods between updates to current duty cycle. Segment field selection is decoded based on the segment index. The segment index equation utilized depends on the [SYMMETRY](#) bit in the [LED Configuration Register](#) Register)

- In Symmetric Mode the `Segment_Index[2:0] = Duty Cycle Bits[7:5]`
- In Asymmetric Mode the `Segment_Index[2:0]` is the bit concatenation of following: `Segment_Index[2] = (FALLING RAMP TIME in Figure 32-3, "Clipping Example")` and `Segment_Index[1:0] = Duty Cycle Bits[7:6]`.

This register may be written at any time. Values written into the register are held in an holding register, which is transferred into the actual register at the end of a PWM period if the Enable Update bit in the LED Configuration register is set to 1. Reads of this register return the current contents and not the value of the holding register.

MEC1725

Offset	10h			
Bits	Description	Type	Default	Reset Event
31:28	<p>UPDATE_INTERVAL7 The number of PWM periods between updates to current duty cycle when the segment index is equal to 111b.</p> <p>15=Wait 16 PWM periods ... 0=Wait 1 PWM period</p>	R/W	0h	RESET_SYS
27:24	<p>UPDATE_INTERVAL6 The number of PWM periods between updates to current duty cycle when the segment index is equal to 110b.</p> <p>15=Wait 16 PWM periods ... 0=Wait 1 PWM period</p>	R/W	0h	RESET_SYS
23:20	<p>UPDATE_INTERVAL5 The number of PWM periods between updates to current duty cycle when the segment index is equal to 101b.</p> <p>15=Wait 16 PWM periods ... 0=Wait 1 PWM period</p>	R/W	0h	RESET_SYS
19:16	<p>UPDATE_INTERVAL4 The number of PWM periods between updates to current duty cycle when the segment index is equal to 100b.</p> <p>15=Wait 16 PWM periods ... 0=Wait 1 PWM period</p>	R/W	0h	RESET_SYS
15:12	<p>UPDATE_INTERVAL3 The number of PWM periods between updates to current duty cycle when the segment index is equal to 011b.</p> <p>15=Wait 16 PWM periods ... 0=Wait 1 PWM period</p>	R/W	0h	RESET_SYS
11:8	<p>UPDATE_INTERVAL2 The number of PWM periods between updates to current duty cycle when the segment index is equal to 010b.</p> <p>15=Wait 16 PWM periods ... 0=Wait 1 PWM period</p>	R/W	0h	RESET_SYS

Offset	10h			
Bits	Description	Type	Default	Reset Event
7:4	UPDATE_INTERVAL1 The number of PWM periods between updates to current duty cycle when the segment index is equal to 001b. 15=Wait 16 PWM periods ... 0=Wait 1 PWM period	R/W	0h	RESET_SYS
3:0	UPDATE_INTERVAL0 The number of PWM periods between updates to current duty cycle when the segment index is equal to 000b. 15=Wait 16 PWM periods ... 0=Wait 1 PWM period	R/W	0h	RESET_SYS

32.10.6 LED OUTPUT DELAY

This register permits the transitions for multiple blinking/breathing LED outputs to be skewed, so as not to present too great a current load. The register defines a count for the number of clocks the circuitry waits before turning on the output, either on initial enable, after a resume from Sleep, or when multiple outputs are synchronized through the Sync control in the LED CONFIGURATION (LED_CFG) register.

When more than one LED outputs are used simultaneously, the LED OUTPUT DELAY fields of each should be configured with different values so that the outputs are skewed. When used with the 32KHz clock domain as a clock source, the differences can be as small as 1.

Offset	14h			
Bits	Description	Type	Default	Reset Event
31:8	Reserved	RES	-	-
7:0	OUTPUT_DELAY The delay, in counts of the clock defined in Clock Source (CLKSRC), in which output transitions are delayed. When this field is 0, there is no added transition delay. When the LED is programmed to be Always On or Always Off, the Output Delay field has no effect.	R/W	000h	RESET_SYS

33.0 PROCHOT MONITOR

33.1 Overview

This block monitors the **PROCHOT#** signal generated by the host processor. It is designed to detect single assertions and monitor cumulative PROCHOT active time.

33.2 References

No references have been cited for this chapter.

33.3 Terminology

There is no terminology defined for this section.

33.4 Interface

This block is designed to be accessed externally via the pin interface and internally via a registered host interface.

FIGURE 33-1: I/O DIAGRAM OF BLOCK

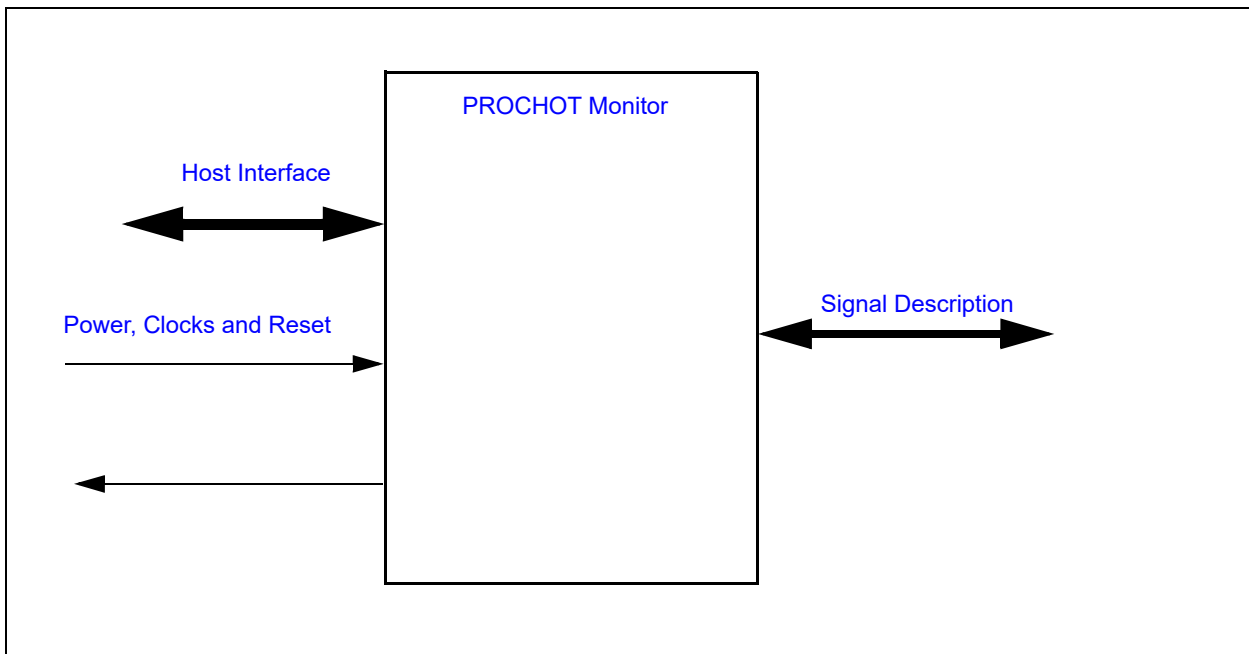

33.4.1 SIGNAL DESCRIPTION

TABLE 33-1: SIGNAL DESCRIPTION

Name	Direction	Description
PROCHOT#	Input	<p>PROCHOT# is an active low signal generated by some processors to indicate the processor is running hot. This signal is used to throttle the processors clocks and as notification to the system.</p> <p>Some processors are equipped with a bi-directional PROCHOT# pin. This PROCHOT block in combination with a PWM can be used to support a bi-directional PROCHOT# pin.</p>

33.4.2 HOST INTERFACE

The registers defined for the [PROCHOT Monitor](#) are accessible by the various hosts as indicated in [Section 33.9, "EC Registers"](#).

33.5 Power, Clocks and Reset

This section defines the Power, Clock, and Reset parameters of the block.

33.5.1 POWER DOMAINS

Name	Description
VTR1	The logic and registers implemented in this block are powered by this power well.

33.5.2 CLOCK INPUTS

Name	Description
48MHz	This is the clock source for this block
100KHz	This is the clock source for filters and counters

33.5.3 RESETS

Name	Description
RESET_SYS	This signal resets all the registers and logic in this block to their default state.
RESET_PHOT	This signal resets all the logic and registers in this block when RESET_SYS is asserted and when the PHOT_RESET bit is asserted by software. This reset is not affected by Low Power Modes .
RESET_SLP	This signal resets all the logic and registers in this block when PHOT_RESET is asserted and when the block is commanded to sleep by the Sleep_Enable signal.

33.6 Interrupts

This section defines the Interrupt Sources generated from this block.

Source	Description
PHOT	PHOT events are generated when either a single PROCHOT Assertion event is detected or a Cumulative PROCHOT Assertion is detected. A PROCHOT Assertion event is generated when the PHOT_ASSERT bit is asserted if the ASSERT_ENABLE bit is set to one. A Cumulative PROCHOT Assertion event is generated when the PHOT_PERIOD bit is asserted if the PERIOD_ENABLE bit is set to one.

33.7 Low Power Modes

The [PROCHOT Monitor](#) may be put into a low power state by the chip's Power, Clocks, and Reset (PCR) circuitry. The block will immediately enter sleep when commanded, resetting any internal counters and filters back to their initial state.

33.8 Description

The [PROCHOT](#) logic defaults to disabled (i.e., not monitoring). To enable the [PROCHOT](#) function, set the [PROCHOT Enable](#) bit in the [PROCHOT Status/Control Register](#) to one.

The [PROCHOT Monitor](#) block supports two types of monitoring features:

- [PROCHOT Assertion Monitoring](#)
- [PROCHOT Cumulative Duty Cycle Monitoring](#)

Note: A 3-stage filter is implemented to prevent system noise from being detected as a processor hot event. If enabled via the [FILT_ENABLE](#) bit, this filter will always reject an high or low pulses that are less than two times the [100KHz](#) clock period.

33.8.1 PROCHOT ASSERTION MONITORING

The [PROCHOT Monitor](#) block is equipped with an internal counter, referred to as the PROCHOT Assertion Counter, that increments when the [PROCHOT#](#) signal is active (i.e., low) and is reset to zero when the [PROCHOT#](#) signal is inactive (i.e., high). The host may read the current value of this counter at any time via the [PROCHOT Assertion Counter Register](#). If the value of this counter is greater than or equal to the value programmed in the [PROCHOT Assertion Counter Register](#) the [PHOT_ASSERT](#) status bit is set to one. This sticky status bit will remain set until either the bit is reset by the defined hardware reset event or software clears the bit. If the [ASSERT_ENABLE](#) bit is set, the [PHOT_ASSERT](#) status bit will trigger a [PHOT](#).

33.8.2 PROCHOT CUMULATIVE DUTY CYCLE MONITORING

The [PROCHOT Cumulative Duty Cycle Monitoring](#) feature measures the total amount of time the [PROCHOT#](#) signal is active (i.e., low) for a specified period of time. The period is programmable in the [PROCHOT Duty Cycle Period Register](#).

To enable the [PROCHOT Cumulative Duty Cycle Monitoring](#) feature the [PROCHOT Monitor](#) block must be enabled via the [PHOT_ENABLE](#) bit and the [PROCHOT Duty Cycle Period Register](#) must be set to a value greater than zero. When the [PROCHOT Cumulative Duty Cycle Monitoring](#) feature is enabled the internal counters associated with this feature are initialized. The [PROCHOT Active Counter](#), which is used to measure the total amount of time the [PROCHOT#](#) signal is active during a specified period, is reset to zero. The [PROCHOT Period Counter](#), which is used to determine the PROCHOT period being monitored, is initialized to the value programmed in the [PROCHOT Duty Cycle Period Register](#). Once enabled, these internal counters will run continuously until either the block is disabled or the [PROCHOT Duty Cycle Period Register](#) is written to zero.

33.8.2.1 PROCHOT Active Counter

- Increments when the [PROCHOT#](#) signal is active (i.e., low) and is held static when the [PROCHOT#](#) signal is inactive (i.e., high).
- The [PROCHOT Active Counter](#) is reset to zero when the [PROCHOT Monitor](#) block is disabled, when the [PROCHOT Duty Cycle Period Register](#) is written, and when the [PROCHOT Period Counter](#) reaches zero. The host may read the current value of this counter at any time via the [PROCHOT Cumulative Count Register](#).

33.8.2.2 PROCHOT Period Counter

- Decrements from the programmed PROCHOT Duty Cycle Period until counter reaches zero.
- When the duty cycle counter reaches zero:
 - The [PROCHOT Cumulative Count Register](#), which contains the filtered [PROCHOT Active Counter](#) value, is loaded into the [PROCHOT Duty Cycle Count Register](#)
 - The [PROCHOT Active Counter](#) is reset to zero.
 - The [PHOT_PERIOD](#) bit is set in the [PROCHOT Status/Control Register](#).
 - The [PROCHOT Period Counter](#) is reloaded from the [PROCHOT Duty Cycle Period Register](#).

33.8.2.3 PROCHOT Cumulative Duty Cycle Filter

A filter has been implemented to discard any invalid active time. The minimum required assertion period for a valid [PROCHOT#](#) signal is 500µS. Pulses less than 500µS should be ignored. The [PROCHOT Active Counter](#) is used to remove low-going pulses that are less than this threshold. This is done by discarding any counter incremental values that are less than or equal to 50 [100KHz](#) clock pulses.

Figure 33-2, "Effects of PROCHOT# Filtering" shows the effect of PROCHOT# input filtering:

FIGURE 33-2: EFFECTS OF PROCHOT# FILTERING

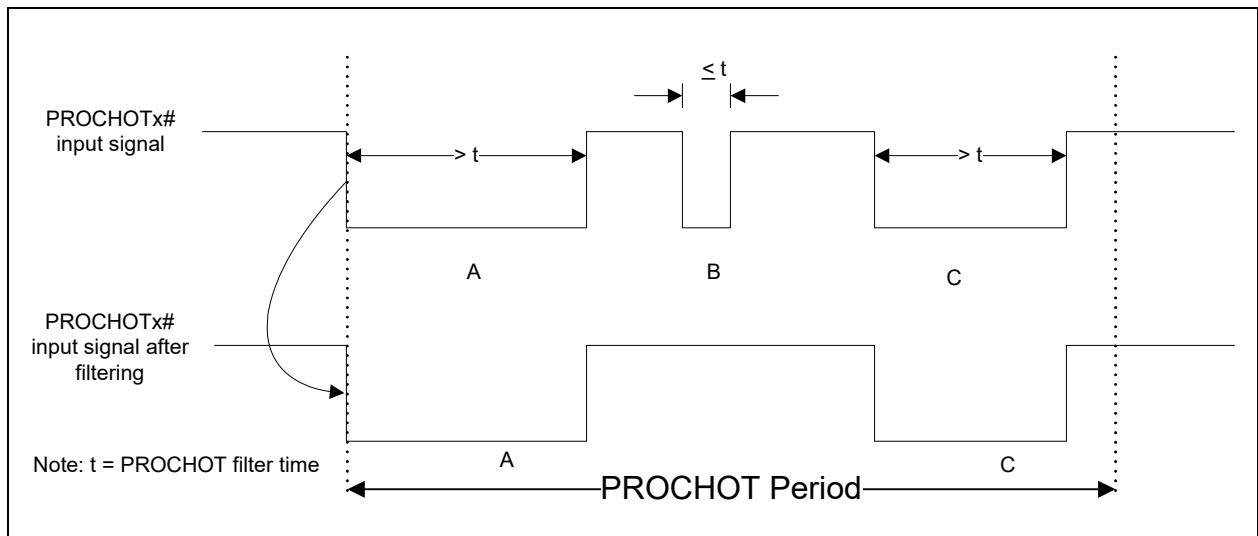
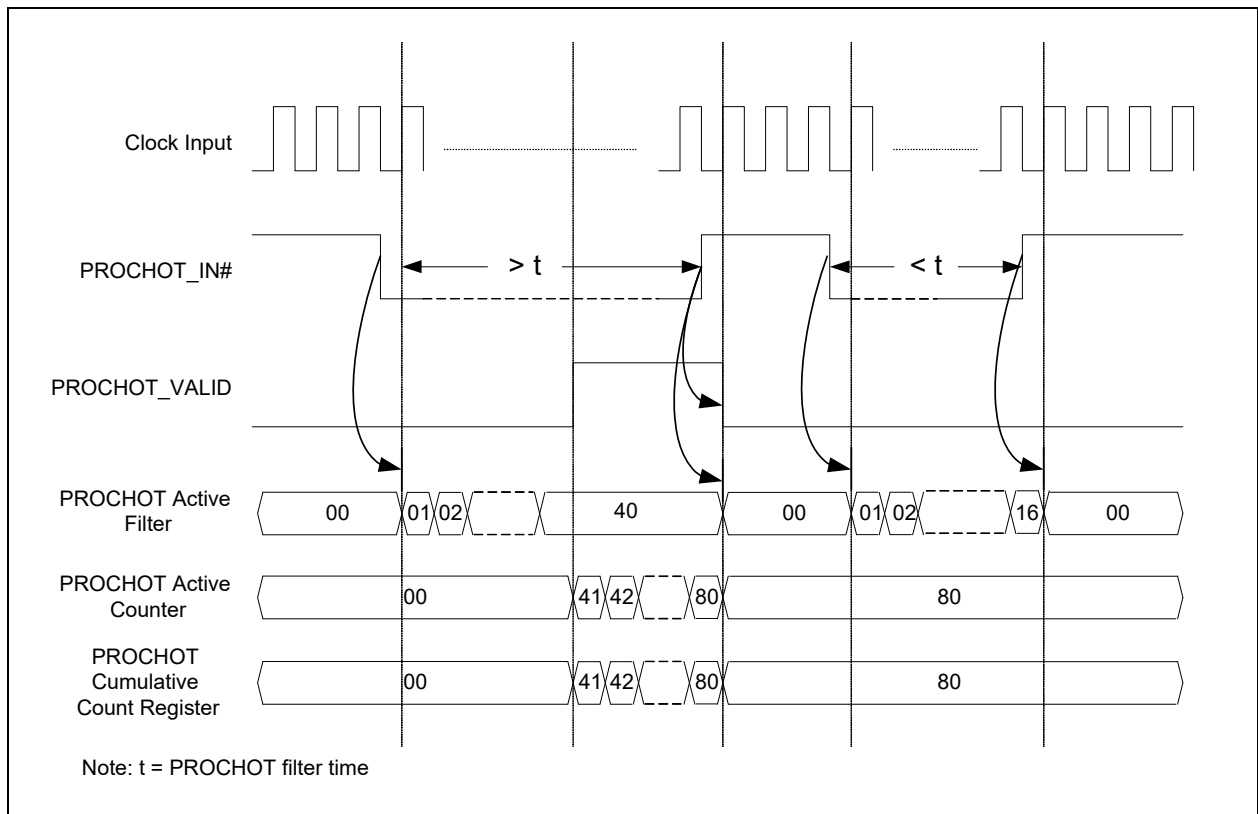

Figure 33-3, "Example of PROCHOT Active Counter" provides an example of the interaction between the internal PROCHOT Cumulative Duty Cycle Filter, PROCHOT Active Counter and the PROCHOT Cumulative Count Register.

FIGURE 33-3: EXAMPLE OF PROCHOT Active Counter



MEC1725

33.8.2.4 Determining a PROCHOT Cumulative Duty Cycle

This hardware may be used by firmware to determine the cumulative duty cycle of the **PROCHOT#** signal. The cumulative duty cycle (the percentage of time that PROCHOT was asserted for a period longer than the filter time) is derived from the **PROCHOT Duty Cycle Count Register** and the **PROCHOT Duty Cycle Period Register**. The duty cycle can be calculated using the relation:

$$DutyCycle = \frac{PROCHOT\ Duty\ Cycle\ Count}{PROCHOT\ Duty\ Cycle\ Period}$$

Figure 33-4, "PROCHOT Duty Cycle Example" shows an example of how the Cumulative Count, Duty Cycle Count and Duty Cycle Period registers relate. The numbers are arbitrary and are for illustration purposes only:

FIGURE 33-4: PROCHOT Duty Cycle Example

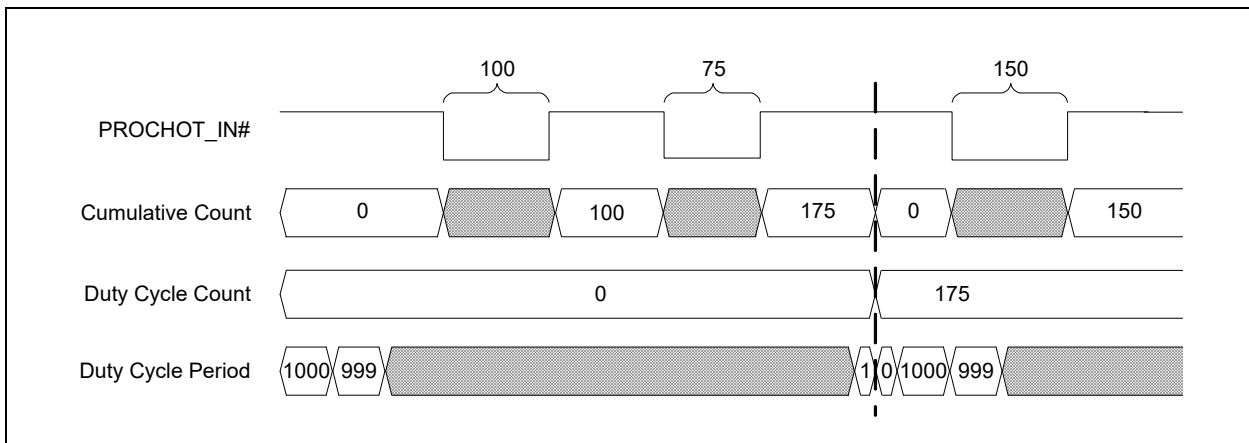

33.9 EC Registers

Registers for this block are shown in the following summary table. Addresses for each register are determined by adding the offset to the Base Address for each instance of the **PROCHOT Monitor** Block in the Block Overview and Base Address Table in [Section 3.0, "Device Inventory"](#).

TABLE 33-2: REGISTER SUMMARY

Offset	Register Name
00h	PROCHOT Cumulative Count Register
04h	PROCHOT Duty Cycle Count Register
08h	PROCHOT Duty Cycle Period Register
0Ch	PROCHOT Status/Control Register
10h	PROCHOT Assertion Counter Register
14h	PROCHOT Assertion Counter Limit Register

33.9.1 PROCHOT CUMULATIVE COUNT REGISTER

Whenever byte 0 of this register is read, bytes 1, 2 and 3 are held in a holding register. Subsequent reads of 8-bits or 16-bits to bytes other than byte 0 return data from the holding register, although the actual register may continue to be updated by hardware. A 32-bit read always returns the current register value.

Offset	00h			
Bits	Description	Type	Default	Reset Event
31:24	Reserved	R	-	-
23:0	CUMULATIVE_PROCHOT_ACTIVE This register contains the current filtered PROCHOT Active Counter value. This register returns the value of the internal PROCHOT Active Counter . When PROCHOT# transitions from low to high (from active to inactive) this register retains its most recent value. This register, as well as the internal PROCHOT Active Counter , are cleared to 0 when this register is copied into the PROCHOT Duty Cycle Count Register on the 1 to 0 transition of the internal Duty Cycle Counter.	R	00_0000h	RESET_SLP

33.9.2 PROCHOT DUTY CYCLE COUNT REGISTER

Whenever byte 0 of this register is read, bytes 1, 2 and 3 are held in a holding register. Subsequent reads of 8-bits or 16-bits to bytes other than byte 0 return data from the holding register, although the actual register may continue to be updated by hardware. A 32-bit read always returns the current register value.

Offset	04h			
Bits	Description	Type	Default	Reset Event
31:24	Reserved	R	-	-
23:0	DUTY_CYCLE_COUNT The contents of the PROCHOT Cumulative Count Register is copied into this register when the PROCHOT Duty Cycle Period Register transitions from 1 to 0.	R	0h	RESET_SLP

MEC1725

33.9.3 PROCHOT DUTY CYCLE PERIOD REGISTER

Offset	08h			
Bits	Description	Type	Default	Reset Event
31:24	Reserved	R	-	-
23:0	<p>DUTY_CYCLE_PERIOD</p> <p>This register defines the number of 100KHz periods required for a duty cycle measurement. It can be programmed for periods from one 100KHz period to $2^{24}-1$ 100KHz periods. As long as the PROCHOT device is enabled, the PROCHOT Period Counter repeatedly counts down from this value to 0. When the counter transitions from 1 to 0, the contents of the PROCHOT Cumulative Count Register are copied into the PROCHOT Duty Cycle Count Register. The status bit in the register is set and the counter is reloaded from this register.</p> <p>Setting this register to 0 disables duty cycle measurement.</p> <p>When this register is written, both the internal PROCHOT Active Counter and the PROCHOT Cumulative Count Register are reset to 0.</p>	R/W	0b	RESET_PHOT

33.9.4 PROCHOT STATUS/CONTROL REGISTER

Offset	0Ch			
Bits	Description	Type	Default	Reset Event
15:12	Reserved	R	-	-
11	<p>PHOT_PERIOD</p> <p>This sticky status bit is set to '1b' when the PROCHOT Period Counter transitions from '1b' to '0b.' It is cleared when written by software with a '1b' or when a hardware reset event occurs. Writes of '0b' have no affect.</p>	R/WC	0b	RESET_SLP
10	<p>PHOT_ASSERT</p> <p>This bit is set when the PROCHOT Assertion Counter Register value is greater than or equal to the PROCHOT Assertion Counter Limit Register value. It is cleared when written with a '1b,' if the counter value is no longer violating the limit or by a hardware reset event. Writes of '0b,' and writes of '1b' when the counter is violating the limit, have no affect.</p>	R/WC	0b	RESET_SLP
9:6	Reserved	R	-	-

Offset	0Ch			
Bits	Description	Type	Default	Reset Event
5	FILT_ENABLE This bit determines whether a digital filter eliminates pulses less than 3 100KHz pulses wide and potentially up to 4 100KHz pulses wide on the PROCHOT# signal before PROCHOT# is sampled by the Assertion counter or the Active counter. 1=PROCHOT# input filtered 0=PROCHOT# input not filtered	R/W	0b	RESET_PHOT
4	PHOT_RESET Writing this self-clearing bit to one resets all the registers and logic in the PROCHOT Monitor block to its defined initial state. Writing a zero to this bit has no effect	R/W	0b	RESET_PHOT
3	PERIOD_ENABLE This bit determines whether or not an interrupt will be generated when the PHOT_PERIOD bit is set. 1=PROCHOT Duty Cycle Period Event interrupt enabled 0=PROCHOT Duty Cycle Period Event interrupt blocked	R/W	0b	RESET_PHOT
2	ASSERT_ENABLE This bit determines whether or not an interrupt will be generated when the PHOT_ASSERT bit is set. 1=PROCHOT Assertion Event interrupt enabled 0=PROCHOT Assertion Event interrupt blocked	R/W	0b	RESET_PHOT
1	PHOT_PIN When PHOT_ENABLE is '1'b, this bit reflects the state of the PROCHOT# Pin input. When PHOT_ENABLE is '0'b, the pin is not monitored and this bit is not updated. 1=PROCHOT Pin is high 0=PROCHOT Pin is low	R	0b	RESET_SLP
0	PHOT_ENABLE This bit enables the PROCHOT Monitor logic. When Enable is 0, no status bits in this register or any of the counters in this block will be updated, although the registers can still be read by the EC. 1=PROCHOT Monitoring 0=PROCHOT Idle (default). This mode gates the clocks to the PROCHOT I/O block Contents of the registers are not affected.	R/W	0b	RESET_PHOT

33.9.5 PROCHOT ASSERTION COUNTER REGISTER

Whenever byte 0 of this register is read, bytes 1, 2 and 3 are held in a holding register. Subsequent reads of 8-bits or 16-bits to bytes other than byte 0 return data from the holding register, although the actual register may continue to be updated by hardware. A 32-bit read always returns the current register value.

MEC1725

Offset	10h			
Bits	Description	Type	Default	Reset Event
31:16	Reserved	R	-	-
15:0	<p>ASSERTION_COUNTER</p> <p>The PROCHOT Assertion Counter is a 16-bit up-counter that is clocked by the 100KHz and is gated and reset by the PROCHOT# input signal. If enabled, this counter increments when the PROCHOT# input signal is active (low) and is reset to 0000h when the pin is inactive (high). This counter is used to measure a single PROCHOT assertion. This register allows the firmware to read the current count value.</p> <p>This counter is a saturating counter: When it reaches FFFFh, it stops counting rather than rolling over to 0000h.</p>	R	0000h	RESET_SLP

33.9.6 PROCHOT ASSERTION COUNTER LIMIT REGISTER

Offset	14h			
Bits	Description	Type	Default	Reset Event
31:16	Reserved	R	-	-
15:0	<p>ASSERTION_COUNT_LIMIT</p> <p>The PROCHOT Assertion Counter Limit register is compared to the 16-bit PROCHOT Assertion Counter. If the value in the PROCHOT Assertion counter is greater than or equal to the value in the limit register, then the PHOT_ASSERT bit contained in the PROCHOT Status/Control Register is set. In addition, an interrupt will be generated if the ASSERT_ENABLE bit in the PROCHOT Status/Control Register is set.</p> <p>A value of 0000h disables the comparison process.</p>	R/w	0000h	RESET_PHOT

34.0 POWERGUARD

34.1 Overview

The PowerGuard Voltage Monitor logic, used in combination with the PROCHOT# Monitor logic, the Analog-to-Digital Converter and a PWM, provides a mechanism to monitor power supplies and if the supplies are operating out of range, throttle the CPU by asserting the PROCHOT# signal. The Voltage Monitor logic is used to filter the output of the ADC.

34.2 References

No references have been cited for this chapter.

34.3 Terminology

There is no terminology defined for this section.

34.4 Interface

This block is designed to be accessed externally via the pin interface and internally via a registered host interface.

FIGURE 34-1: I/O DIAGRAM OF BLOCK

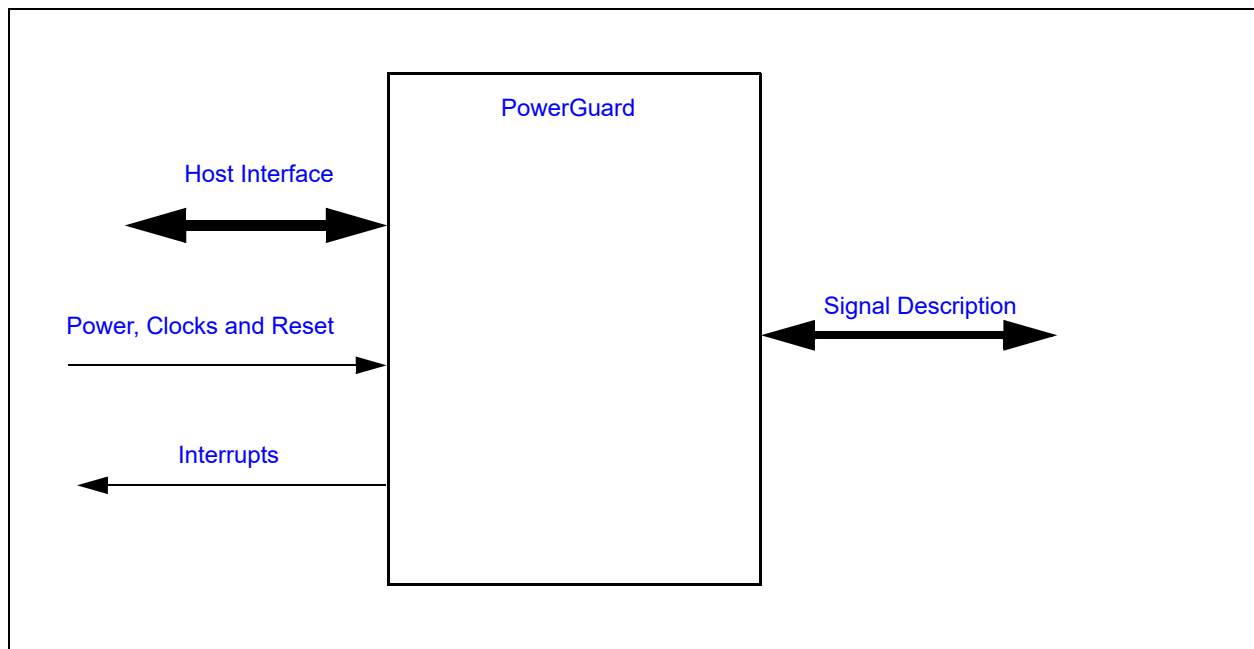

MEC1725

34.5 Signal Description

TABLE 34-1: EXTERNAL SIGNAL DESCRIPTION TABLE

Name	Direction	Description
PROCHOT#	Input/Output	PROCHOT# is an active low signal generated by some processors to indicate the processor is running hot. This version of the signal is used to throttle the processors clocks and as notification to the system. It is driven as an output by the PowerGuard logic.
VCI_OVRD_IN	Input	When Pin input is low the PROCHOT#_OUT is driven low regardless the state of the other contributions to PROCHOT OUTPUT ORing Logic
V_ISYS[n:0]	Input	The V_ISYS0 analog input is routed to ADC channel 0. The V_ISYS1 analog input is routed to ADC channel 1.

TABLE 34-2: INTERNAL SIGNAL DESCRIPTION TABLE

Name	Direction	Description
FORCE_PROCHOT#	Input	This input comes from a PWM. The PROCHOT_IO# pin can be asserted with a square wave, using this signal as a source.
PHOT	Input	Input from the PROCHOT Monitor. This signal is asserted by the PROCHOT Monitor when the assertion duty cycle of the PROCHOT_IN# pin exceeds a set limit. It is the same signal as the PHOT interrupt.

34.6 Host Interface

The registers defined for the [PowerGuard](#) are accessible by the System Host and the Embedded Controller as indicated in [Section 34.13, "EC Registers"](#).

34.7 Power, Clocks and Reset

This section defines the Power, Clock, and Reset parameters of the block.

34.7.1 POWER DOMAINS

Name	Description
VTR_REG	The logic and registers implemented in this block are powered by this power well.

34.7.2 CLOCK INPUTS

Name	Description
48MHz	This is the clock source for this block

34.7.3 RESETS

Name	Description
RESET_SYS	This signal resets all the registers and logic in this block to their default state.

34.8 Interrupts

This section defines the Interrupt Sources generated from this block.

TABLE 34-3: EC INTERRUPTS

Source	DESCRIPTION
POWERGUARD	<p>The POWERGUARD interrupt is asserted when any of the following bits in the PowerGuard Interrupt Status Register are asserted and enabled by the corresponding bit in the PowerGuard Interrupt Enable Register:</p> <ul style="list-style-type: none"> • FORCE_PROCHOT • CT_LO_L2H • CT_HI_L2H • CT_LO_H2L • CT_HI_H2L

34.9 Low Power Modes

Each block instance enters low power when the [BLOCK_DISABLE](#) bit is set in the corresponding [Control And Status Register](#).

34.10 Description

The PROCHOT interface with PowerGuard Technology provides a monitoring and control solution for a PROCHOT# interface. The solution comprises four different blocks:

- The [Analog to Digital Converter](#), used to monitor external voltages. One ADC channel is used per PowerGuard monitor. The ADC channel-to-PowerGuard mapping is:
 - PowerGuard Instance 0 is linked to ADC Channel 0
 - PowerGuard Instance 1 is linked to ADC Channel 1
- The [PROCHOT Monitor](#), used to monitor the PROCHOT signal output from the CPU
- A [PWM](#) instance, used to generate a FORCE_PROCHOT# throttling signal. The following PWM instance is used for FORCE_PROCHOT#:
 - PWM11
- One or more instances of the PowerGuard voltage monitor circuit, described in this section

The following diagram illustrates the typical PowerGuard implementation. This chapter describes the functionality implemented in a PowerGuard block.

FIGURE 34-2: POWERGUARD SYSTEM DIAGRAM

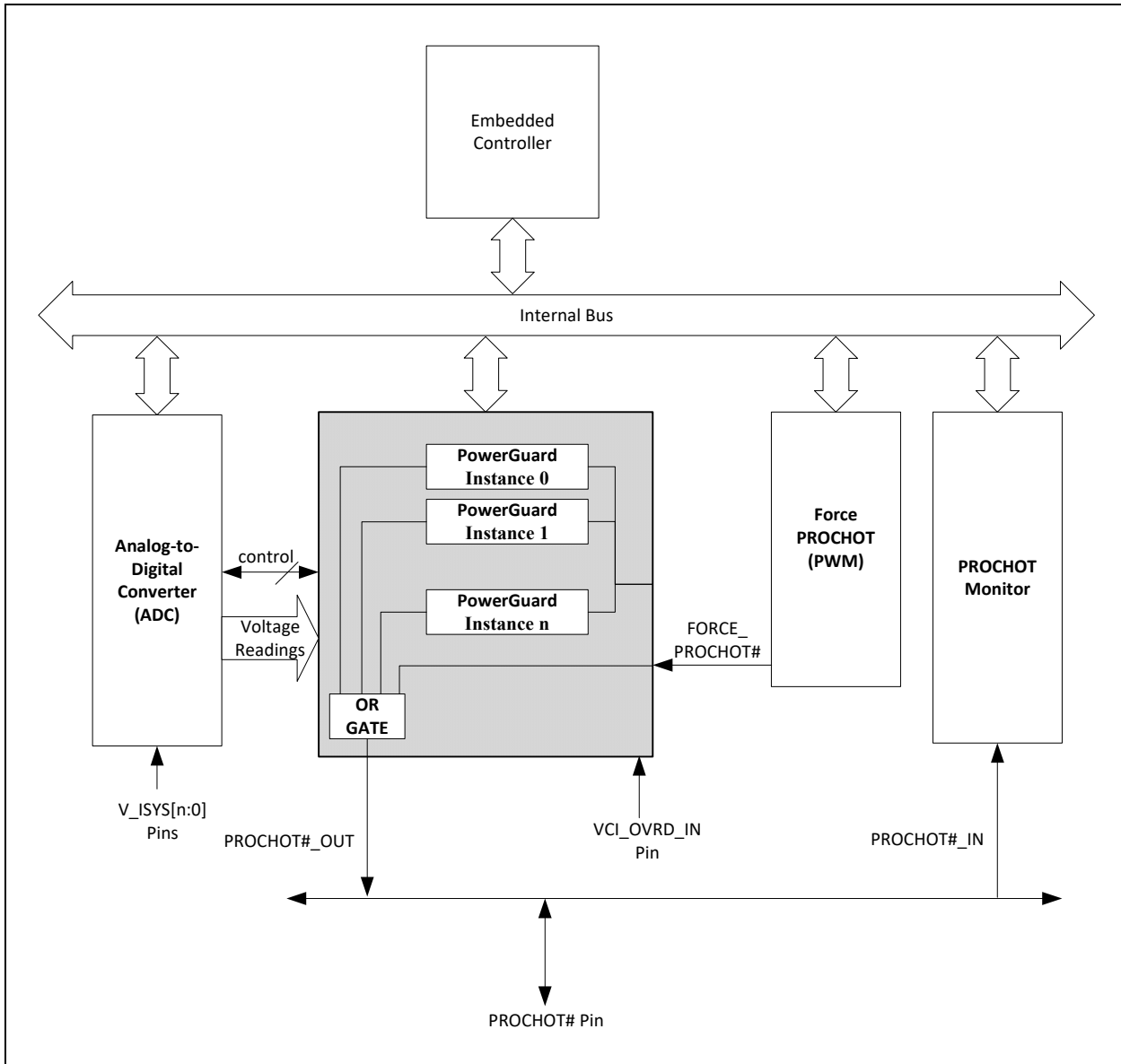

Note: The PROCHOT# pin is associated with a GPIO. The GPIO must be configured as an open-drain output with maximum drive strength to operate as a PROCHOT# signal. The GPIO alternate function field must be set either to PROCHOT_IN# (option 1) or PROCHOT_IO# (option 2). The PROCHOT# output function will only operate when the GPIO is configured for PROCHOT_IO#. The PROCHOT Monitor functions when the GPIO is configured for either PROCHOT_IN# or PROCHOT_IO#.

Each **PowerGuard** instance generates a PROCHOT#_OUT signal. Each of these PROCHOT#_OUT signals are OR'd together to create a single PROCHOT#_OUT signal from the **PowerGuard** block as illustrated in [Figure 34-2, "PowerGuard System Diagram"](#). The remainder of this description focuses on a single **PowerGuard** Instance.

As illustrated in [Figure 34-3](#), a **PowerGuard** instance consists of the following:

- The **Front End Data Input** selects the source sample data for the remainder of the circuit.
- The **Second Order LPF**

- The [Prochot Data Mux](#) selects what data is forwarded to the [Prochot Comparators](#).
- The [Prochot Comparators](#) which compare the PROCHOT Data to two reference values.
- The [Timers](#) which provide delay to the comparator outputs prior to PROCHOT ORing Logic.
- The PROCHOT [ORing Logic](#) adds in the various contributions to the [PROCHOT#](#) pin

The following figure is a block diagram of two instances of the PowerGuard logic, including the external PWM and ADC which are shown in blue:

FIGURE 34-3: POWERGUARD BLOCK DIAGRAM

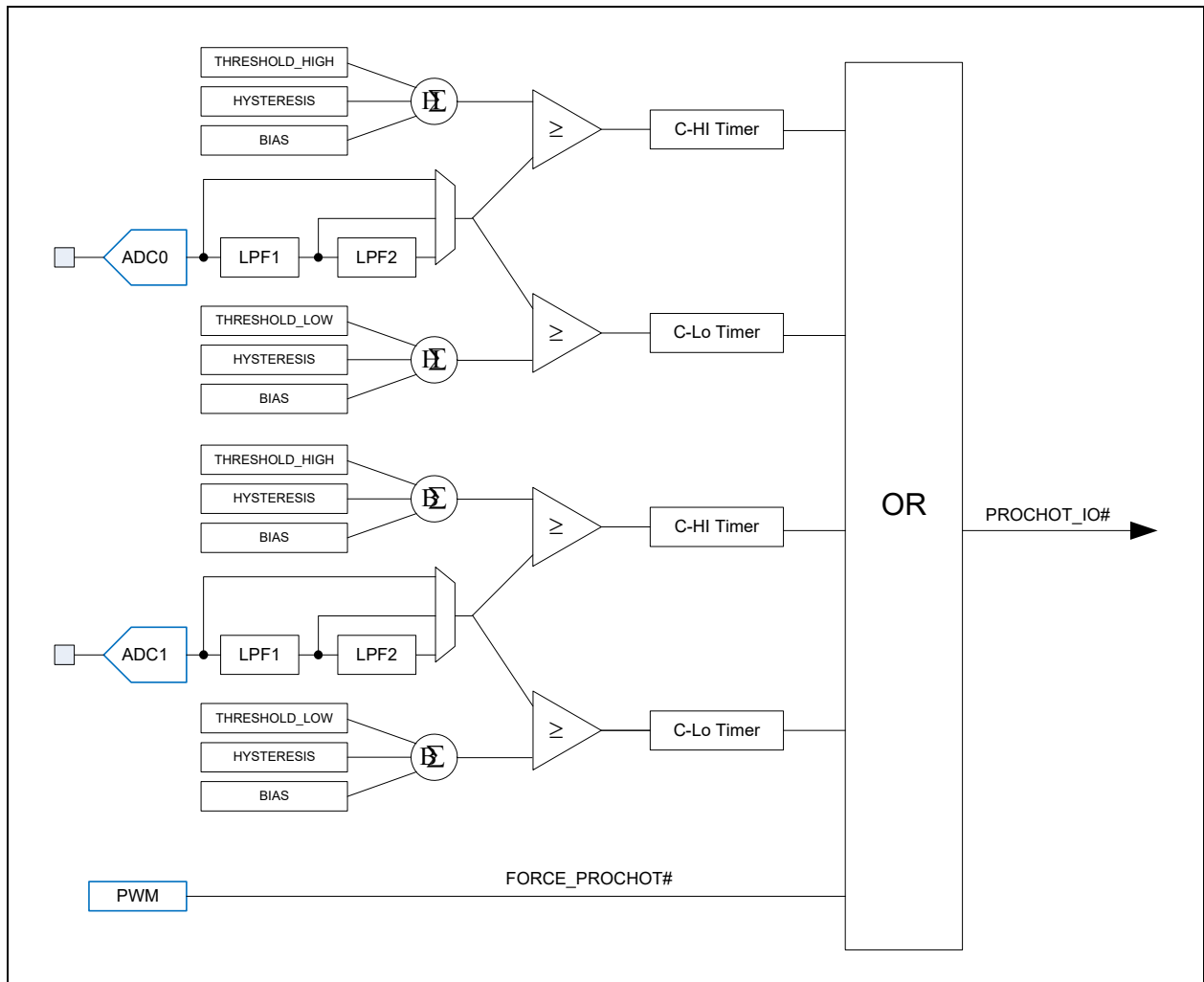

34.10.1 FRONT END DATA INPUT

The Front End Data Input phase of the PowerGuard logic collects data from an ADC channel. For testing purposes, the ADC input can be bypassed with test data provided under firmware control. The bypass is controlled by the [TEST_DATA_MUX_SELECT](#) bit in the [Control And Status Register](#). Test data is written into the [TEST_WRITE_DATA](#) of the [Data Register](#).

The ADC samples input data with 10-bit precision. ADC data routed to the PowerGuard logic are limited to 8 bits, consisting of the most significant 8 bits of the ADC 10-bit samples. If the ADC reference voltage is 3.3V, the least significant bit of an 8-bit sample therefore represents $3.3V/256$ or approximately 12.9mV.

The output of the ADC and [TEST_WRITE_DATA](#) field have the same 8-bit format.

34.10.2 SECOND ORDER LPF

The ADC data is filtered through a second order linear-predictive filter. The second order filtering is accomplished using two identical first order filters in series.

Two factors affect the filter performance:

- The sample rate at which voltage samples are input to the filter
- The number of samples that are averaged together. The averaging can be over 4 samples or 64 samples

The frequency of sampling is determined by the [LPF1_CUTOFF_FREQ](#) and [LPF2_CUTOFF_FREQ](#) fields in the [LPF1 Frequency Cut-off Rate Register](#) and [LPF2 Frequency Cut-off Rate Register](#), respectively. The averaging window is determined by the [WEIGHT](#) bits in the two registers.

EQUATION 34-1: SAMPLE RATE CALCULATIONS

$$RawSampleRate = \frac{48MHz}{LPFxCUTOFFREQ}$$

$$AveragedSampleRate = \frac{RawSampleRate}{WEIGHT}$$

Examples of sample rates are shown in [Table 34-4, "Example ADC Oversampling Rates"](#).

34.10.2.1 Filter Design Description

Each first-order filter contains a 14-bit accumulator, with the binary point between bit 6 and bit 5 (that is, 8 integer bits and 6 fractional bits). The most significant 8 bits represent a voltage in the same format as the 8-bit ADC readings; the least significant 6 bits are a fraction of the LSB of an 8-bit sample. Samples from the [Front End Data Input](#) are averaged over a moving window; the size of the window is determined by the Weight fields ([WEIGHT](#) in the [LPF1 Frequency Cut-off Rate Register](#), [WEIGHT](#) in the [LPF2 Frequency Cut-off Rate Register](#)). When the Weight is set to 64 (the default), the averaging window is 64 samples. The following equation shows how the running average is calculated:

EQUATION 34-2: LPF AVERAGING

$$Average = Average - \frac{Average}{W} + \frac{Sample}{W}$$

In the equation, *Average* is the integral portion of the accumulator (the most significant 8 bits), *W* is the averaging window (either 4 or 64) and *Sample* is a sample delivered by the [Front End Data Input](#).

34.10.2.2 ADC Oversampling

The ADC can deliver samples at a maximum rate of 1MHz; this rate is divided by the number of channels that are enabled for conversion. When the LPF filters are configured for a sample rate that exceeds the rate at which the ADC can deliver readings, the ADC readings are oversampled (that is, the same reading is input to the filter more than once).

TABLE 34-4: EXAMPLE ADC OVERSAMPLING RATES

LPF1_CUTOFF_FREQ	Sample Rate	Sample Rate after Averaging, Window = 64	Average ADC Oversampling, 1 ADC Channel Enabled	Average ADC Oversampling, 2 ADC Channels Enabled
00000h	48 MHz	750 KHz	48.0	96.0
00004h	9.6 MHz	150 KHz	9.60	19.2
00010h	2.82 MHz	44.1 KHz	2.82	5.65

TABLE 34-4: EXAMPLE ADC OVERSAMPLING RATES (CONTINUED)

LPF1_CUTOFF_FREQ	Sample Rate	Sample Rate after Averaging, Window = 64	Average ADC Oversampling, 1 ADC Channel Enabled	Average ADC Oversampling, 2 ADC Channels Enabled
00020h	1.45 MHz	22.7 KHz	1.45	2.91
00030h	980 KHz	15.3 KHz	No oversampling	1.96
00040h	738 KHz	11.5 KHz	No oversampling	1.48
00048h	657 KHz	10.3 KHz	No oversampling	1.32
0004Ah	640 KHz	10.0 KHz	No oversampling	1.28
00060h	495 KHz	7.7 KHz	No oversampling	No oversampling
> 00060h	-	-	No oversampling	No oversampling

34.10.2.3 First Order Filter Input Response

Figure 34-4 illustrated the input response of the First Order Filter. The input (V_{in}) is normalized to 100. The input waveform consists of a long pulse high to show the step function response of the filter followed by a squarewave of 20 samples high/20 samples low.

Three curves are shown:

1. WEIGHT bit = '1' (Averaging window $W=4$)
2. WEIGHT bit = '0' (Averaging window $W=64$)
3. WEIGHT bit = '0' (Averaging window $W=64$, each ADC reading oversampled 5 times)

FIGURE 34-4: FIRST ORDER FILTER INPUT RESPONSE

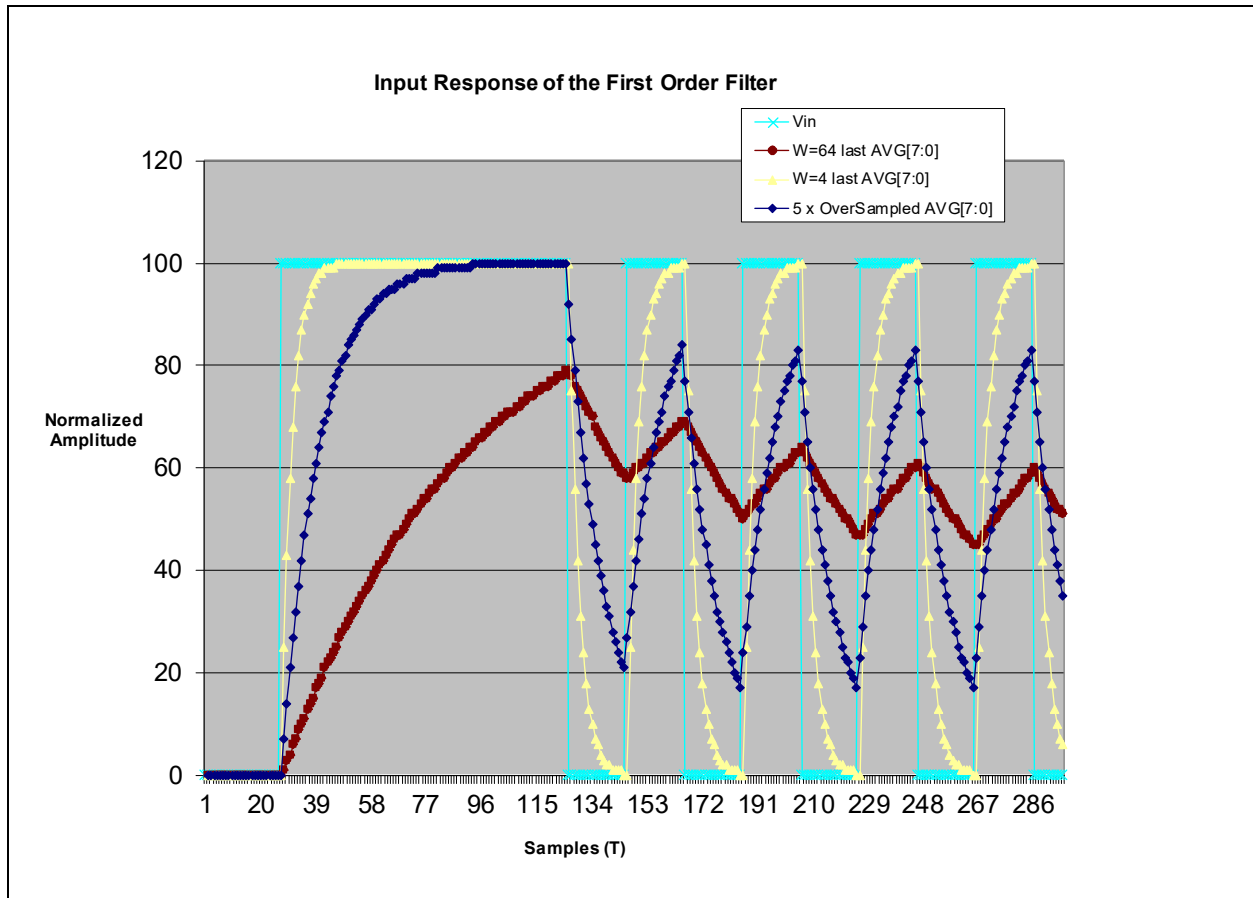

MEC1725

34.10.2.4 Second Order Filter Implementable

The second-order LPF is composed of two first-order LPFs that are cascaded. Each LPF is implemented as described in [Section 34.10.2.1, "Filter Design Description"](#). The first LPF is defined by parameters in the [LPF1 Frequency Cut-off Rate Register](#) and the second LPF is defined by parameters in the [LPF2 Frequency Cut-off Rate Register](#). The second LPF may be bypassed. The connectivity is shown in [Figure 34-3, "PowerGuard Block Diagram"](#).

34.10.3 PROCHOT DATA MUX

The Prochot Data Mux selects which data are forwarded to the comparators that determine when the voltage is out of range. The choices are:

- 8-bit unfiltered data from the ADC
- The output of the initial first-order LPF
- The output of the second-order LPF

34.10.4 PROCHOT COMPARATORS

The output of the PROCHOT Data Mux is compared to two thresholds in order to determine if the voltage is out of a permitted range. The high-side comparator asserts if its input is greater than or equal to the high reference value, and the low-side comparator asserts if its input is less than or equal to the low reference value.

The reference value for each comparator has three components: a threshold, a bias and a hysteresis value. All values are 8 bits, in the same format as the ADC readings. There is a separate threshold setting for the high-side comparator ([THRESHOLD_HIGH](#)) and the low-side comparator ([THRESHOLD_LOW](#)). The same bias settings ([BIAS](#)) and hysteresis settings ([HYSTERESIS](#)) are used for both comparators. All four values are located in the [Threshold Limit Register](#).

Note: The sum of either [THRESHOLD_LOW](#)+[BIAS](#)+[HYSTERESIS](#) or [THRESHOLD_HIGH](#)+[BIAS](#)+[HYSTERESIS](#) must not exceed FFh.

Hysteresis is always enabled on both comparators. Hysteresis can be either positive or negative, which is set independently for the two comparators.

34.10.4.1 Positive Hysteresis Mode Equations

The input Data must rise above the level of $THRESHOLD + BIAS + HYSTERESIS$ for the comparator to switch from low to high state. In pseudo-code:

```
if( output == 1 )
    output = input COMPARE (THRESHOLD + Bias)
else
    output = input COMPARE (THRESHOLD + Bias + Hysteresis)
```

where COMPARE is ">=" for the high-side comparator and "<=" for the low-side comparator, and THRESHOLD is [THRESHOLD_HIGH](#) for the high-side comparator and [THRESHOLD_LOW](#) for the low-side comparator.

34.10.4.2 Negative Hysteresis Mode Equations

The input Data must fall below the level of $THRESHOLD + BIAS - HYSTERESIS$ for the comparator to switch from low to high state. In pseudo-code:

```
if( output == 0 )
    output = input COMPARE (THRESHOLD + Bias)
else
    output = input COMPARE (THRESHOLD + Bias - Hysteresis)
```

where COMPARE is ">=" for the high-side comparator and "<=" for the low-side comparator, and THRESHOLD is [THRESHOLD_HIGH](#) for the high-side comparator and [THRESHOLD_LOW](#) for the low-side comparator.

34.10.5 TIMERS

The High Timer and the Low Timer provide programmable delays to the output of the high-side comparator and the low-side comparator, respectively. Each timer has a 2ms resolution, a max delay of 8.192 seconds, and can be disabled to provide a pass-through signal from its corresponding comparator output. The High Timer is configured with the [HIGH_TIMER Register](#) and the Low Timer is configured with the [LOW_TIMER Register](#).

Each timer counts down from a programmable preload value down to zero while the comparator output is asserted. When the comparator output is de-asserted, the associated timer is reset to the preload value. The timer is also set to the preload value any time the preload value is reprogrammed. Once a timer counts down to zero, it can assert PROCHOT_OUT# if its output is enabled.

Recovery Mode effects the timer's contribution to PROCHOT_OUT#. Once asserted, the Recovery Mode determines when the timer output is de-asserted.

In Auto Recover Mode, the timer output to PROCHOT_OUT# is de-asserted as soon as the timer is reset and stops asserting. In Manual Recovery Mode, the assertion of PROCHOT_OUT# persists even after the timer is reset.

In Manual Recovery Mode, once a timer times out and generates an assertion to the ORing Logic, the assertion will remain until firmware sets the [MANUAL_RECOVERY](#) bit in the [Control And Status Register](#) to '0b', even if the comparator subsequently stops asserting.

If both the high-side timer and the low-side timer are configured for Manual Recovery Mode, the [MAN_RECOVERY_OUT](#) status bit in the [Control And Status Register](#) can be used to monitor when either of the timers is actively asserting PROCHOT_OUT# to the ORing Logic. If either the high-side timer and the low-side timer are in Auto Recovery Mode, the [MAN_RECOVERY_OUT](#) bit is invalid.

34.10.6 ORING LOGIC

The [ORing Logic](#) logically OR's the various contributions to [PROCHOT#](#). Each contribution has a separate enable bit in the [Control And Status Register](#). The following signals are OR'd together to generate the PROCHOT_OUT# signal.

- The [FORCE_PROCHOT#](#) input from the PROCHOT PWM. This component is enabled by the [FORCE_PROCHOT_ENABLE](#) bit in the [Control And Status Register](#). Whenever the PROCHOT PWM is asserted low, the PROCHOT_OUT# signal is asserted low
- Assertion from the high-side timer. This component is enabled by s enabled by the [CTMER_OUT_HI_ENABLE](#) bit in the [Control And Status Register](#)
- Assertion from the low-side timer. This component is enabled by s enabled by the [CTMR_OUT_LO_ENABLE](#) bit in the [Control And Status Register](#)

34.11 General Use

34.11.1 POWERGUARD SETUP

The general usage model is to setup all the register setting and then enable the block via the [BLOCK_DISABLE](#) bit in the [Control And Status Register](#).

If the [FORCE_PROCHOT](#) input is required as a component of the ORing Logic, then the following steps must be performed before modifying the [Control And Status Register](#):

- Set the INVERT bit in the PWMx Configuration Register of the PROCHOT PWM to '1b'. This configures the PROCHOT PWM as an active low output
- Clear the [FORCE_PROCHOT](#) bit in the [PowerGuard Interrupt Status Register](#) by writing the bit with a '1b'

34.11.2 POWERGUARD PROPAGATION DELAY

Propagation Delay through the ADC/[PowerGuard](#) Circuit obeys the following equation

$T_{prop} = (\text{Channels_Enabled} \times \text{ADC Acquisition}) + \text{LPF1 Delay} + \text{LPF2 Delay} + \text{Programmed Timer Delay} + \text{Processor PROCHOT\# assertion to P-State change}$

- Channels_Enabled = Integer value determined by number of ADC channels enabled for monitoring
- ADC Acquisition = 1µs/channel (max)
- LPF delay is $(1/\text{Sample_Rate}) \times \text{Averaging_Window}$

34.12 Typical Application Example

Requirement to provide a 10k pole LPF capable of passing a 900µs pulse.

The input (Vin) is normalized to 100, so ADC input values range between 0 and 64h (that is, between 0V and 1.29V). The input waveform consists of a squarewave of 90 ADC samples high/90 ADC samples low. Assume input has 25mv of noise pedestal and you want to use an 80%/20% threshold detection with 60mV Hysteresis using Positive Hysteresis & Negative Hysteresis Modes similar to a Schmitt trigger.

Set up the ADC to sample at the maximum rate (without delay), for a sampling rate of 1MHz. This is the default setting.

MEC1725

Program the [LPF1 Frequency Cut-off Rate Register](#) to 48h which results in the following settings:

- [WEIGHT](#) = 64
- [LPF1_SAMPLE_EQ_ADC](#) = Sampling is controlled by [LPF1_CUTOFF_FREQ](#).
- LPF1 Cut-off frequency (F_C) = 10KHz
- LPF1 Sample Rate (F_S) = 640KHz
- Oversample Rate = no oversampling

Program the [Threshold Limit Register](#) to create the following settings:

- [BIAS](#) = 0
- [THRESHOLD_HIGH](#) = 50h (80% of full scale)
- [THRESHOLD_LOW](#) = 14h (20% of full scale)
- [HYSTERESIS](#) = 5 (about 60mV)
- [HIGH_COMPARATOR_HYSTERESIS_MODE](#) = Positive Hysteresis Mode
- [LOW_COMPARATOR_HYSTERESIS_MODE](#) = Negative Hysteresis Mode

Figure 34-5, "LPF Example Waveforms" shows how the [AVG\[7:0\]](#) output responds to the squarewave input by reaching 63% of V_{in} in 100 μ s.

FIGURE 34-5: LPF EXAMPLE WAVEFORMS

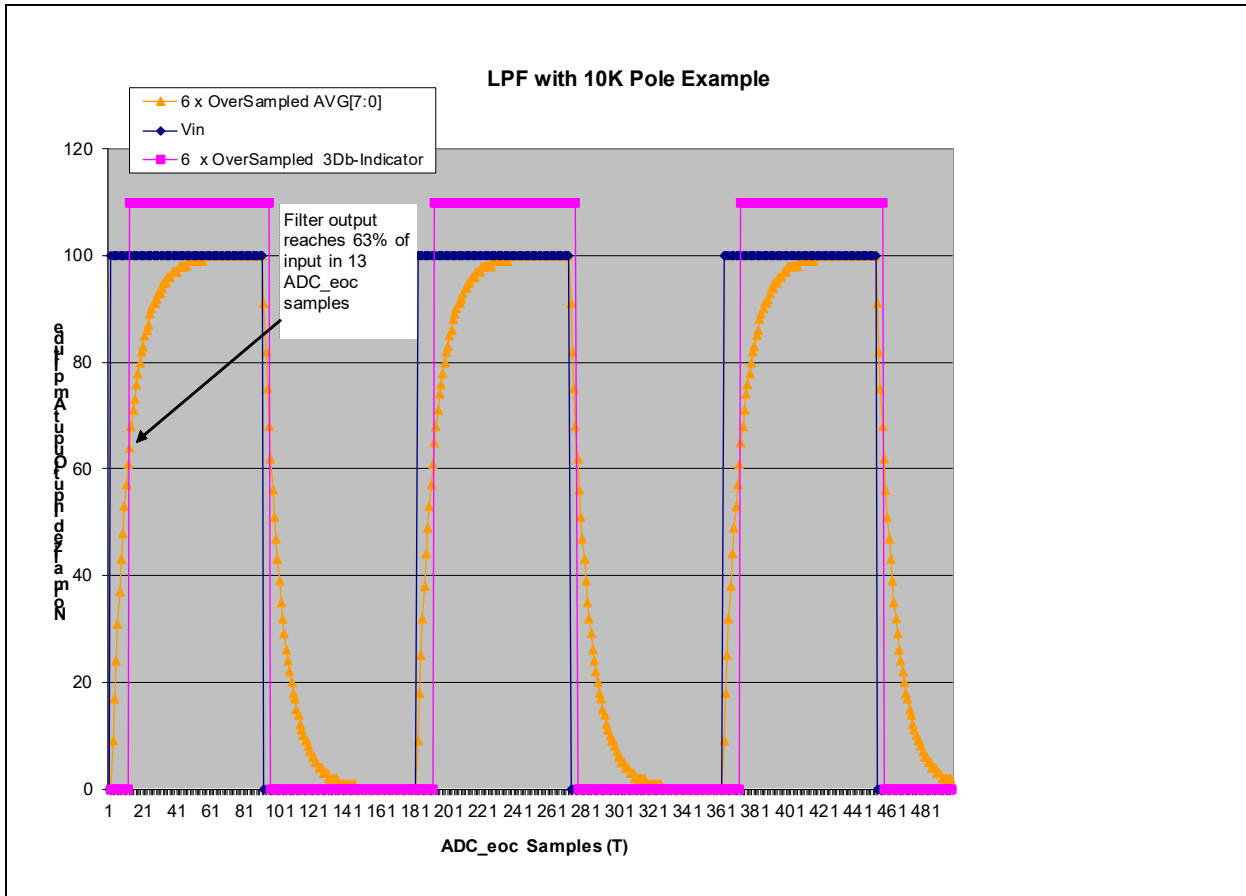

34.13 EC Registers

Registers for this block are shown in the following summary table. Addresses for each register are determined by adding the offset to the Base Address for each instance of the [PowerGuard](#) Block in the Block Overview and Base Address Table in [Section 3.0, "Device Inventory"](#).

TABLE 34-5: REGISTER SUMMARY

Offset	REGISTER NAME (Mnemonic)
00h	LPF1 Frequency Cut-off Rate Register
04h	LPF2 Frequency Cut-off Rate Register
08h	Data Register
0Ch	Threshold Limit Register
10h	LOW_TIMER Register
14h	HIGH_TIMER Register
18h	Control And Status Register
1Ch	PowerGuard Interrupt Status Register
20h	PowerGuard Interrupt Enable Register

34.13.1 LPF1 FREQUENCY CUT-OFF RATE REGISTER

Offset	00h			
Bits	Description	Type	Default	Reset Event
31:22	Reserved	R	0h	
21	<p>LPF1_SAMPLE_EQ_ADC</p> <p>1=LPF1 samples at the rate of the ADC. There is no oversampling of the ADC input. The LPF1_CUTOFF_FREQ field has no effect 0=LPF1 sampling rate is determined by the LPF1_CUTOFF_FREQ field</p>	R/W	0h	RESET_SYS
20	<p>WEIGHT</p> <p>This bit controls the weight parameter “W” in the First Order Average Equation and the weight parameter “W2” in the Second Order Average Equation for Linear Predictive Filter 1.</p> <p>1=The Weight parameter is 4 0=The Weight parameter is 64</p>	R/W	0h	RESET_SYS
19:0	<p>LPF1_CUTOFF_FREQ</p> <p>The cutoff frequency for the Linear Predictive Filter 1.</p> <p>Only 12 of the 20 bits in this field are writable. The following bits are fixed at ‘0’ (writes to these bits are ignored; reads always return ‘0’): Bits[15:14] Bits[11:8] Bits[1:0]</p>	R, R/W	F0h	RESET_SYS

MEC1725

34.13.2 LPF2 FREQUENCY CUT-OFF RATE REGISTER

Offset	04h			
Bits	Description	Type	Default	Reset Even
31:22	Reserved	R	0h	
21	LPF2_SAMPLE_EQ_ADC 1=LPF2 samples at the rate of the ADC. There is no oversampling of the ADC input. The LPF2_CUTOFF_FREQ field has no effect 0=LPF2 sampling rate is determined by the LPF2_CUTOFF_FREQ field	R/W	0h	RESET_SYS
20	WEIGHT This bit controls the weight parameter “W” in the First Order Average Equation and the weight parameter “W2” in the Second Order Average Equation for Linear Predictive Filter 2. 1=The Weight parameter is 4 0=The Weight parameter is 64	R/W	0h	RESET_SYS
19:0	LPF2_CUTOFF_FREQ The cutoff frequency for the Linear Predictive Filter 2. Only 12 of the 20 bits in this field are writable. The following bits are fixed at '0' (writes to these bits are ignored; reads always return '0'): Bits[15:14] Bits[11:8] Bits[1:0]	R, R/W	F0h	RESET_SYS

34.13.3 DATA REGISTER

Offset	08h			
Bits	Description	Type	Default	Reset Even
31:24	<p>TEST_WRITE_DATA</p> <p>When the TEST_DATA_MUX_SELECT bit in the Control And Status Register is a '1', writes to this register are used as the ADC sample data. The PowerGuard data path is synchronized to the write to this register. Reads of this register return 0. Data written can be read back by selecting ADC Sample Data (option 0) in the SELECTED_BYTE0 field.</p> <p>When the TEST_DATA_MUX_SELECT bit in the Control And Status Register is '0', writes to this register and the contents of this field have no effect.</p> <p>The Timers do not get synchronized to writes to this field.</p>	W	0h	RESET_SYS
23:16	<p>LPF2_OUTPUT_DATA</p> <p>Data output of 2nd Order LPF</p>	R	0h	RESET_SYS
15:8	<p>LPF1_OUTPUT_DATA</p> <p>Data output of 1st Order LPF</p>	R	0h	RESET_SYS
7:0	<p>SELECTED_BYTE0</p> <p>This contents of this read-only field is controlled by the value written into the DATA_MUX_SELECT field in the Control And Status Register. Data are always 8 bits. Options, based on the DATA_MUX_SELECT value, are:</p> <p>111b=Reserved 110b=Theshold data for the low side comparator 101b=Threshold data for the high side comparator 100b=Reserved 010b=The LPF2 accumulator least significant six bits. These 6 bits are shifted left by 2 bits to form this 8-bit data value; the LPF2 Accumulator consists of the field LPF2_OUTPUT_DATA concatenated with bits[7:2]. Bits[1:0] are always 0 001b=The LPF1 accumulator least significant six bits. These 6 bits are shifted left by 2 bits to form this 8-bit data value; the LPF1 Accumulator consists of the field LPF1_OUTPUT_DATA concatenated with bits[7:2]. Bits[1:0] are always 0 000b=ADC Sample Data</p>	R	0h	RESET_SYS

MEC1725

34.13.4 THRESHOLD LIMIT REGISTER

Offset	0Ch			
Bits	Description	Type	Default	Reset Even
31:24	THRESHOLD_HIGH This field contains the base value for setting the comparison threshold for the high-side comparator. It is combined with the BASIS and HYSTERESIS fields in this register to generate the threshold used in the comparison.	R/W	0h	RESET_SYS
23:16	THRESHOLD_LOW This field contains the base value for setting the comparison threshold for the low-side comparator. It is combined with the BASIS and HYSTERESIS fields in this register to generate the threshold used in the comparison.	R/W	0h	RESET_SYS
15:11	HYSTERESIS The contents of this field is added or subtracted both comparator thresholds, based on the hysteresis settings for the comparators.	R/W	0h	RESET_SYS
10:8	Reserved	R	0h	
7:0	BIAS The contents of this field are added to both THRESHOLD_HIGH and THRESHOLD_LOW when generating the comparison thresholds for the high-side and low-side comparators, respectively.	R/W	0h	RESET_SYS

Note: The sum of either THRESHOLD_LOW+BIAS+HYSTERESIS or THRESHOLD_HIGH+BIAS+HYSTERESIS must not exceed FFh.

34.13.5 LOW_TIMER REGISTER

Offset	10h			
Bits	Description	Type	Default	Reset Even
31	LOW_TIMER_RECOVERY_OPTIONS Recovery mode for the low-side timer. 1=Manual Recovery Mode. Once asserted by the low-side timer, PROCHOT_OUT# will remain asserted until firmware sets the MANUAL_RECOVERY bit in the Control And Status Register to '1b' 0=Automatic Recovery Mode. PROCHOT_OUT# assertion from the low-side timer is terminated as soon as the low-side comparator de-asserts	R/W	0h	RESET_SYS
30	TEST_BIT All writes to this register should clear this test bit to '0'.	R/W	0h	RESET_SYS

Offset	10h			
Bits	Description	Type	Default	Reset Even
29:24	Reserved	R		
23:12	<p>LOW_TIMER_LOAD The value written into this field is the Load Count value for the LOW_TIMER_COUNTER. Sample values are:</p> <p>FFFh=A count of 8.19 seconds (maximum) 7D0h=A count of 4.00 seconds 0FAh=A count of 500mS 001h=A count of 2mS (minimum) 000h=Disable the counter. The low-side comparator output signal is passed directly to the ORing Logic</p>	R/W	0h	RESET_SYS
11:0	<p>LOW_TIMER_COUNTER Reads of this field provides the current count of the low-side timer.</p>	R	0h	RESET_SYS

34.13.6 HIGH_TIMER REGISTER

Offset	14h			
Bits	Description	Type	Default	Reset Even
31	<p>HIGH_TIMER_RECOVERY_OPTIONS Recovery mode for the high-side timer.</p> <p>1=Manual Recovery Mode. Once asserted by the high-side timer, PROCHOT_OUT# will remain asserted until firmware sets the MANUAL_RECOVERY bit in the Control And Status Register to '1b' 0=Automatic Recovery Mode. PROCHOT_OUT# assertion from the high-side timer is terminated as soon as the high-side comparator de-asserts</p>	R/W	0h	RESET_SYS
30	<p>TEST_BIT All writes to this register should clear this test bit to '0'.</p>	R/W	0h	RESET_SYS
29:24	Reserved	R		

MEC1725

Offset	14h			
Bits	Description	Type	Default	Reset Even
23:12	HIGH_TIMER_LOAD The value written into this field is the Load Count value for the HIGH_TIMER_COUNTER . Sample values are: FFFh=A count of 8.19 seconds (maximum) 7D0h=A count of 4.00 seconds 0FAh=A count of 500mS 001h=A count of 2mS (minimum) 000h=Disable the counter. The high-side comparator output signal is passed directly to the ORing Logic	R/W	0h	RESET_SYS
11:0	HIGH_TIMER_COUNTER Reads of this field provides the current count of the high-side timer.	R	0h	RESET_SYS

34.13.7 CONTROL AND STATUS REGISTER

Offset	18h			
Bits	Description	Type	Default	Reset Even
31	Reserved	R	0h	
30	PROCHOT#_OUT Current output of the ORing Logic .	R	0h	RESET_SYS
29	TEST	R	0h	RESET_SYS
28	TEST	R	0h	RESET_SYS
27	FORCE_PROCHOT Inverted copy of the current state of the input signal FORCE_PROCHOT# from the PROCHOT PWM.	R	1h	RESET_SYS
26	MAN_RECOVERY_OUT If both the high-side timer and the low-side timer are configured for Manual Recovery Mode, this bit reports the status of the timer contribution to the ORing Logic . If either the high-side timer and the low-side timer are configured for Auto Recovery Mode, this bit is invalid.	R	0h	RESET_SYS
25	CTMR_OUT_HI Status bit of the high-side timer.	R	0h	RESET_SYS
24	CTMR_OUT_LO Status bit of the low-side timer.	R	0h	RESET_SYS

Offset	18h			
Bits	Description	Type	Default	Reset Even
23	BLOCK_RESET When this bit is set to '1b' the entire block is reset. This bit is self clearing.	R/W	0h	RESET_SYS
22	BLOCK_DISABLE When this bit is set to '1b' the PowerGuard block is disabled and placed in a low power state. The PROCHOT# signal is deasserted.	R/W	1h	RESET_SYS
21:20	TEST All writes to this register should clear this test field to '0'.	R/W	0h	RESET_SYS
19:18	TEST All writes to this register should clear this test field to '0'.	R/W	0h	RESET_SYS
17	TEST All writes to this register should clear this test bit to '0'.	R/W	0h	RESET_SYS
16	TEST All writes to this register should clear this test bit to '0'.	R/W	0h	RESET_SYS
15:13	Reserved	R	0h	
12	HIGH_COMPARATOR_HYSTERESIS_MODE This bit selects Hysteresis Mode for the high-side comparator. See Section 34.10.4, "Prochot Comparators" . 1=Negative Hysteresis Mode 0=Positive Hysteresis Mode	R/W	0h	RESET_SYS
11	LOW_COMPARATOR_HYSTERESIS_MODE This bit selects Hysteresis Mode for the low-side comparator. See Section 34.10.4, "Prochot Comparators" . 1=Negative Hysteresis Mode 0=Positive Hysteresis Mode	R/W	0h	RESET_SYS
10:9	PROCHOT_DATA_MUX_SELECT The field controls the source of the Prochot Data Mux . 11=Reserved 10=Source is the output of LPF2; Both LPF1 and LPF2 are enabled 01=Source is the output of LPF2; LPF2 is disabled. 00=Source is ADC; Both LPF1 & LPF2 are disabled	R/W	0h	RESET_SYS

MEC1725

Offset	18h			
Bits	Description	Type	Default	Reset Even
8	<p>TEST_DATA_MUX_SELECT</p> <p>The bit controls the source of the ADC sample data to the Second Order LPF.</p> <p>1=Test mode. The TEST_WRITE_DATA field of the Data Register is the data source for the Second Order LPF.</p> <p>0=Functional mode. The input from the ADC is used as the source for the Second Order LPF.</p>	R/W	0h	RESET_SYS
7	<p>PROCHOT_GATE</p> <p>This bit controls the effect of the VCI_OVRD_IN pin on the PROCHOT# Output.</p> <p>0=The VCI_OVRD_IN pin input has no effect on the PROCHOT# pin.</p> <p>1=The VCI_OVRD_IN pin input effects the PROCHOT#_OUT pin as follows:</p> <ul style="list-style-type: none"> - When the VCI_OVRD_IN pin is low PROCHOT#_OUT is driven low unconditionally. - When the VCI_OVRD_IN pin is high PROCHOT#_OUT is driven by the PROCHOT# ORing Logic 	R/W	0h	RESET_SYS
6:4	<p>DATA_MUX_SELECT</p> <p>The field controls the read data accessible of the SELECTED_BYTE0 field of the Data Register.</p> <p>111b=Reserved 110b=Theshold data for the low side comparator 101b=Threshold data for the high side comparator 100b=Reserved 010b=The LPF2 accumulator least significant six bits. 001b=The LPF1 accumulator least significant six bits. 000b=ADC Sample Data</p>	R/W	0h	RESET_SYS
3	<p>MANUAL_RECOVERY</p> <p>This bit is set to '1b' if either high-side timer or the low-side timer is configured for Manual Recovery Mode and the timer times out and asserts.</p> <p>1=A timer event remains asserted to the ORing Logic</p> <p>0=Events for both the high-side timer and low-side timer are de-asserted. If a timer configured for Manual Recover Mode asserts, this bit changes to '1b'</p> <p>This bit has no effect on any timer in Auto Recovery Mode.</p>	R/W	0h	RESET_SYS
2	<p>FORCE_PROCHOT_ENABLE</p> <p>1=The FORCE_PROCHOT# input from the PROCHOT Monitor block is a component of the ORing Logic that generates PROCHOT_IO#</p> <p>0=The FORCE_PROCHOT# input is masked from the ORing Logic</p>	R/W	1h	RESET_SYS

Offset	18h			
Bits	Description	Type	Default	Reset Even
1	CTMR_OUT_LO_ENABLE 1=The low-side timer output is a component of the ORing Logic that generates PROCHOT_IO# 0=The low-side timer output is masked from the ORing Logic	R/W	0h	RESET_SYS
0	CTMER_OUT_HI_ENABLE 1=The high-side timer output is a component of the ORing Logic that generates PROCHOT_IO# 0=The high-side timer output is masked from the ORing Logic	R/W	0h	RESET_SYS

34.13.8 POWERGUARD INTERRUPT STATUS REGISTER

Offset	1Ch			
Bits	Description	Type	Default	Reset Even
31:5	Reserved	R	0h	
4	FORCE_PROCHOT This bit is set to '1b' if the FORCE_PROCHOT# input from the PROCHOT PWM is low (asserted). This bit is cleared to '0b' when written with a '1b'. Writes of '0b' have no effect.	R/WC	1h	RESET_SYS
3	CT_LO_L2H This bit is set to '1b' when the CTMR_OUT_LO in the Control And Status Register transitions from '0b' to '1b'. This bit is cleared to '0b' when written with a '1b'. Writes of '0b' have no effect.	R/WC	0h	RESET_SYS
2	CT_HI_L2H This bit is set to '1b' when the CTMR_OUT_HI in the Control And Status Register transitions from '0b' to '1b'. This bit is cleared to '0b' when written with a '1b'. Writes of '0b' have no effect.	R/WC	0h	RESET_SYS

MEC1725

Offset	1Ch			
Bits	Description	Type	Default	Reset Even
1	<p>CT_LO_H2L</p> <p>This bit is set to '1'b when the CTMR_OUT_LO in the Control And Status Register transitions from '1b' to '0b'.</p> <p>This bit is cleared to '0b' when written with a '1b'. Writes of '0b' have no effect.</p>	R/WC	0h	RESET_SYS
0	<p>CT_HI_H2L</p> <p>This bit is set to '1'b when the CTMR_OUT_HI in the Control And Status Register transitions from '1b' to '0b'.</p> <p>This bit is cleared to '0b' when written with a '1b'. Writes of '0b' have no effect.</p>	R/WC	0h	RESET_SYS

34.13.9 POWERGUARD INTERRUPT ENABLE REGISTER

Offset	20h			
Bits	Description	Type	Default	Reset Even
31:3	Reserved	R	0h	
4	FORCE_PROCHOT_ENABLE 1=The PowerGuard interrupt is enabled when the FORCE_PROCHOT bit in the PowerGuard Interrupt Status Register is '1'b 0=The FORCE_PROCHOT interrupt is disabled	R/W	0h	RESET_SYS
3	CT_LO_L2H_ENABLE 1=The PowerGuard interrupt is enabled when the FORCE_PROCHOT bit in the PowerGuard Interrupt Status Register is '1'b 0=The FORCE_PROCHOT interrupt is disabled	R/W	0h	RESET_SYS
2	CT_HI_L2H_ENABLE 1=The PowerGuard interrupt is enabled when the FORCE_PROCHOT bit in the PowerGuard Interrupt Status Register is '1'b 0=The FORCE_PROCHOT interrupt is disabled	R/W	0h	RESET_SYS
1	CT_LO_H2L_ENABLE 1=The PowerGuard interrupt is enabled when the FORCE_PROCHOT bit in the PowerGuard Interrupt Status Register is '1'b 0=The FORCE_PROCHOT interrupt is disabled	R/W	0h	RESET_SYS
0	CT_HI_H2L_ENABLE 1=The PowerGuard interrupt is enabled when the FORCE_PROCHOT bit in the PowerGuard Interrupt Status Register is '1'b 0=The FORCE_PROCHOT interrupt is disabled	R/W	0h	RESET_SYS

MEC1725

35.0 RPM-PWM INTERFACE

35.1 Introduction

The [RPM-PWM Interface](#) is a closed-loop RPM based Fan Control Algorithm that monitors a fan's speed and automatically adjusts the drive to the fan in order to maintain the desired fan speed.

The [RPM-PWM Interface](#) functionality consists of a closed-loop "set-and-forget" RPM-based fan controller.

35.2 References

No references have been cited for this chapter

35.3 Terminology

There is no terminology defined for this chapter.

35.4 Interface

This block is designed to be accessed externally via the pin interface and internally via a registered host interface.

The registers in the block are accessed by embedded controller code at the addresses shown in [Section 35.9, "EC Registers"](#).

FIGURE 35-1: RPM-PWM INTERFACE I/O DIAGRAM

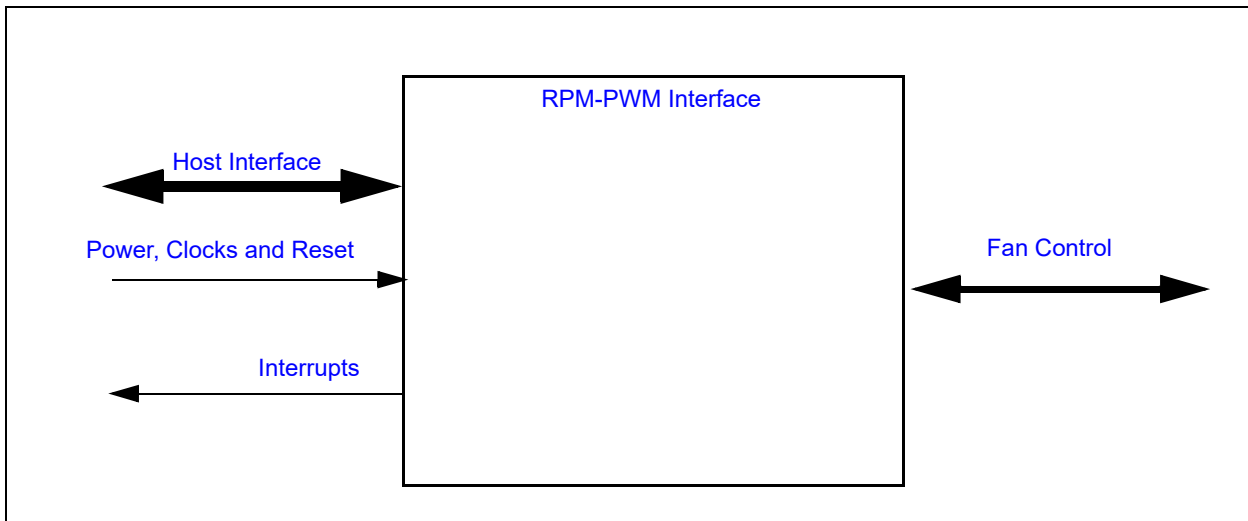

35.4.1 FAN CONTROL

The Fan Control Signal Description Table lists the signals that are routed to/from the block.

Name	Direction	Description
GTACH	Input	Tachometer input from fan
GPWM	Output	PWM fan drive output

35.4.2 HOST INTERFACE

The registers defined for the [RPM-PWM Interface](#) are accessible by the various hosts as indicated in [Section 35.9, "EC Registers"](#).

35.5 Power, Clocks and Reset

This section defines the Power, Clock, and Reset parameters of the block.

35.5.1 POWER DOMAINS

Name	Description
VTR_CORE	This power well sources the registers and logic in this block.

35.5.2 CLOCK INPUTS

Name	Description
48MHz	This clock signal drives selected logic (e.g., counters).
32KHz Core	This clock signal drives selected logic (e.g., counters).

35.5.3 RESETS

Name	Description
RESET_SYS	This reset signal resets all of the registers and logic in this block.

35.6 Interrupts

This section defines the Interrupt Sources generated from this block.

Source	Description
FAN_FAIL	The DRIVE_FAIL & FAN_SPIN bits in the Fan Status Register are logically ORed and routed to the FAIL_SPIN Interrupt
FAN_STALL	The FAN_STALL bit in the Fan Status Register is routed to the FAN_STALL Interrupt

35.7 Low Power Modes

The [RPM-PWM Interface](#) may be put into a low power state by the chip's Power, Clocks, and Reset (PCR) circuitry.

35.8 Description

This section defines the functionality of the block.

35.8.1 GENERAL OPERATION

The [RPM-PWM Interface](#) is an RPM based Fan Control Algorithm that monitors the fan's speed and automatically adjusts the drive to maintain the desired fan speed. This RPM based Fan Control Algorithm controls a PWM output based on a tachometer input.

35.8.2 FAN CONTROL MODES OF OPERATION

The [RPM-PWM Interface](#) has two modes of operation for the PWM Fan Driver. They are:

1. Manual Mode - in this mode of operation, the user directly controls the fan drive setting. Updating the Fan Driver Setting Register (see [Section 35.9.1, "Fan Setting Register"](#)) will update the fan drive based on the programmed ramp rate (default disabled).
 - The Manual Mode is enabled by clearing the EN_ALGO bit in the Fan Configuration Register (see [Section 35.9.2, "Fan Configuration Register"](#)).
 - Whenever the Manual Mode is enabled the current drive settings will be changed to what was last used by the RPM control algorithm.
 - Setting the drive value to 00h will disable the PWM Fan Driver.
 - Changing the drive value from 00h will invoke the Spin Up Routine.
2. Using RPM based Fan Control Algorithm - in this mode of operation, the user determines a target tachometer reading and the drive setting is automatically updated to achieve this target speed.

Manual Mode	Algorithm
Fan Driver Setting (read / write)	Fan Driver Setting (read only)
EDGES[1:0] (Fan Configuration)	EDGES[1:0] (Fan Configuration)
UPDATE[2:0] (Fan configuration)	UPDATE[2:0] (Fan configuration)
LEVEL (Spin Up Configuration)	LEVEL (Spin Up Configuration)
SPINUP_TIME[1:0] (Spin Up Configuration)	SPINUP_TIME[1:0] (Spin Up Configuration)
Fan Step	Fan Step
-	Fan Minimum Drive
Valid TACH Count	Valid TACH Count
-	TACH Target
TACH Reading	TACH Reading
RANGE[2:0] (Fan Configuration 2)	RANGE[2:0] (Fan Configuration 2)
-	DRIVE_FAIL_CNT[2:0] (Spin Up Config) and Drive Fail Band

35.8.3 RPM BASED FAN CONTROL ALGORITHM

The [RPM-PWM Interface](#) includes an RPM based Fan Control Algorithm.

The fan control algorithm uses Proportional, Integral, and Derivative terms to automatically approach and maintain the system's desired fan speed to an accuracy directly proportional to the accuracy of the clock source. [Figure 35-2, "RPM based Fan Control Algorithm"](#) shows a simple flow diagram of the RPM based Fan Control Algorithm operation.

The desired tachometer count is set by the user inputting the desired number of 32.768KHz cycles that occur per fan revolution. The user may change the target count at any time. The user may also set the target count to FFh in order to disable the fan driver.

For example, if a desired RPM rate for a 2-pole fan is 3000 RPMs, the user would input the hexadecimal equivalent of 1312d (52_00h in the TACH Target Registers). This number represents the number of 32.768KHz cycles that would occur during the time it takes the fan to complete a single revolution when it is spinning at 3000RPMs (see [Section 35.9.10, "TACH Target Register"](#) and [Section 35.9.11, "TACH Reading Register"](#)).

The [RPM-PWM Interface's](#) RPM based Fan Control Algorithm has programmable configuration settings for parameters such as ramp-rate control and spin up conditions. The fan driver automatically detects and attempts to alleviate a stalled/stuck fan condition while also asserting the interrupt signal. The [RPM-PWM Interface](#) works with fans that operate up to 16,000 RPMs and provide a valid tachometer signal.

FIGURE 35-2: RPM BASED FAN CONTROL ALGORITHM

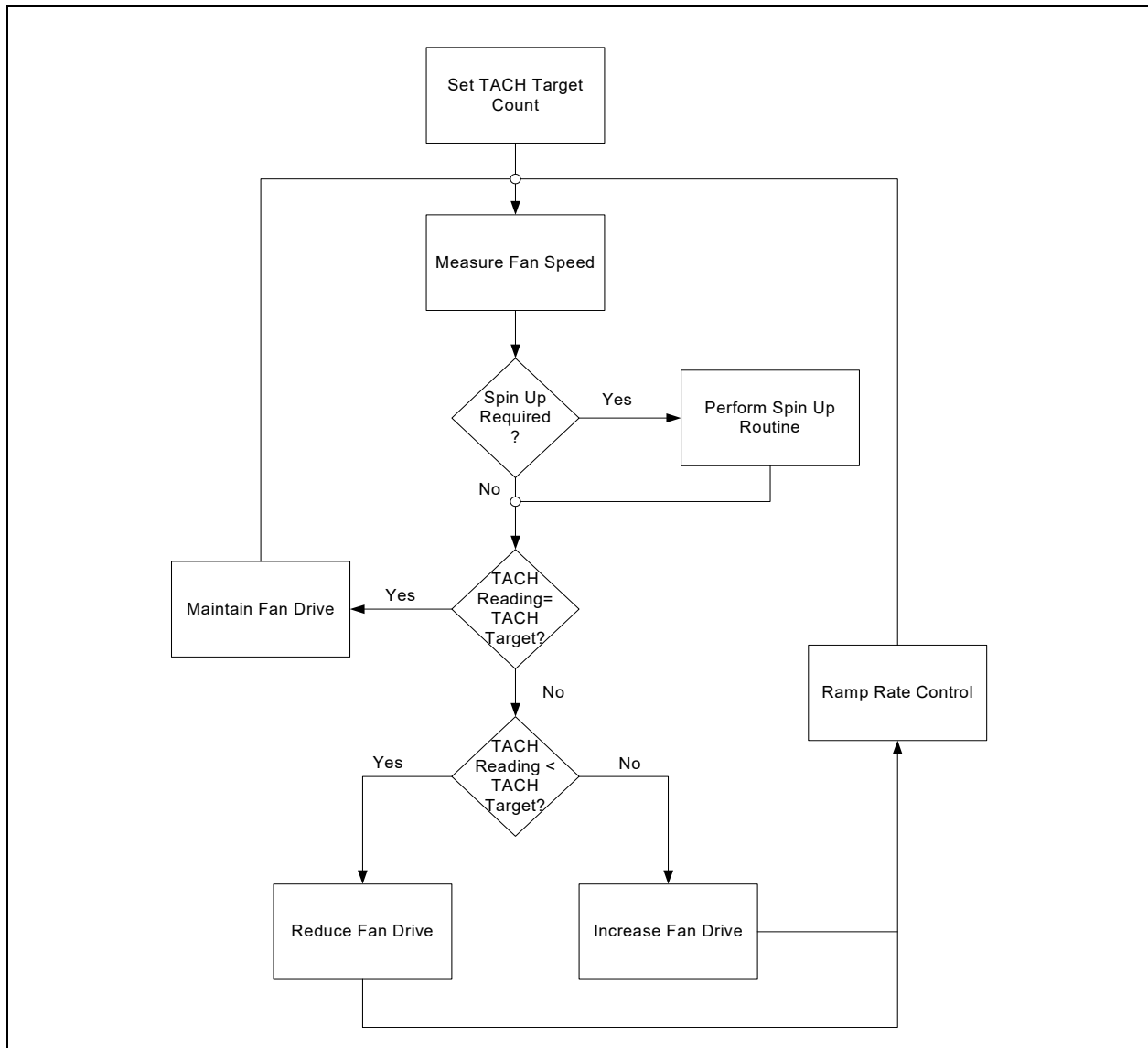

35.8.3.1 Programming the RPM Based Fan Control Algorithm

The RPM based Fan Control Algorithm powers-up disabled. The following registers control the algorithm. The [RPM-PWM Interface](#) fan control registers are pre-loaded with defaults that will work for a wide variety of fans so only the TACH Target Register is required to set a fan speed. The other fan control registers can be used to fine-tune the algorithm behavior based on application requirements.

1. Set the Valid TACH Count Register to the minimum tachometer count that indicates the fan is spinning.
2. Set the Spin Up Configuration Register to the spin up level and Spin Time desired.
3. Set the Fan Step Register to the desired step size.
4. Set the Fan Minimum Drive Register to the minimum drive value that will maintain fan operation.
5. Set the Update Time, and Edges options in the Fan Configuration Register.
6. Set the TACH Target Register to the desired tachometer count.
7. Enable the RPM based Fan Control Algorithm by setting the EN_ALGO bit.

35.8.3.2 Tachometer Measurement

In both modes of operation, the tachometer measurement operates independently of the mode of operation of the fan driver and RPM based Fan Speed Control algorithm. Any tachometer reading that is higher than the Valid TACH Count (see [Section 35.9.8, "Valid TACH Count Register"](#)) will flag a stalled fan and trigger an interrupt.

When measuring the tachometer, the fan must provide a valid tachometer signal at all times to ensure proper operation. The tachometer measurement circuitry is programmable to detect the fan speed of a variety of fan configurations and architectures including 1-pole, 2-pole (default), 3-pole, and 4-pole fans.

Note: The tachometer measurement works independently of the drive settings. If the device is put into manual mode and the fan drive is set at a level that is lower than the fan can operate (including zero drive), the tachometer measurement may signal a Stalled Fan condition and assert an interrupt.

STALLED FAN

If the TACH Reading Register exceeds the user-programmable Valid TACH Count setting, it will flag the fan as stalled and trigger an interrupt. If the RPM based Fan Control Algorithm is enabled, the algorithm will automatically attempt to restart the fan until it detects a valid tachometer level or is disabled.

The FAN_STALL Status bit indicates that a stalled fan was detected. This bit is checked conditionally depending on the mode of operation.

- Whenever the Manual Mode is enabled or whenever the drive value is changed from 00h, the FAN_STALL interrupt will be masked for the duration of the programmed Spin Up Time (see [Section 35.9.5, "Fan Spin Up Configuration Register"](#)) to allow the fan an opportunity to reach a valid speed without generating unnecessary interrupts.
- In Manual Mode, whenever the TACH Reading Register exceeds the Valid TACH Count Register setting, the FAN_STALL status bit will be set.
- When the RPM based Fan Control Algorithm, the stalled fan condition is checked whenever the Update Time is met and the fan drive setting is updated. It is not a continuous check.

35.8.3.3 Spin Up Routine

The [RPM-PWM Interface](#) also contains programmable circuitry to control the spin up behavior of the fan driver to ensure proper fan operation. The Spin Up Routine is initiated under the following conditions:

- The TACH Target High Byte Register value changes from a value of FFh to a value that is less than the Valid TACH Count (see [Section 35.9.8, "Valid TACH Count Register"](#)).
- The RPM based Fan Control Algorithm's measured tachometer reading is greater than the Valid TACH Count.
- When in Manual Mode, the Drive Setting changes from a value of 00h.

When the Spin Up Routine is operating, the fan driver is set to full scale for one quarter of the total user defined spin up time. For the remaining spin up time, the fan driver output is set to a user defined level (30% to 65% drive).

After the Spin Up Routine has finished, the [RPM-PWM Interface](#) measures the tachometer. If the measured tachometer reading is higher than the Valid TACH Count Register setting, the FAN_SPIN status bit is set and the Spin Up Routine will automatically attempt to restart the fan.

Note: When the device is operating in manual mode, the FAN_SPIN status bit may be set if the fan drive is set at a level that is lower than the fan can operate (excluding zero drive which disables the fan driver). If the FAN_SPIN interrupt is unmasked, this condition will trigger an errant interrupt.

[Figure 35-3, "Spin Up Routine"](#) shows an example of the Spin Up Routine in response to a programmed fan speed change based on the first condition above.

FIGURE 35-3: SPIN UP ROUTINE

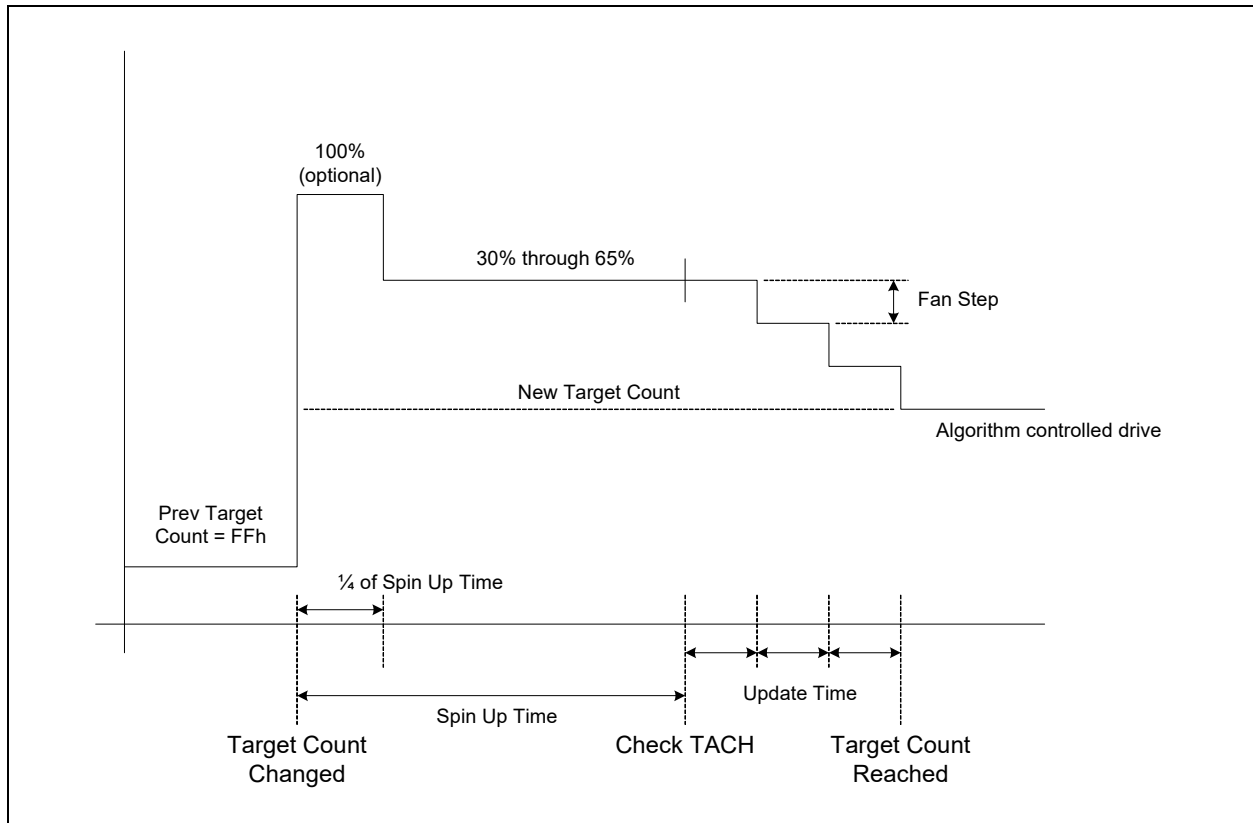

35.8.4 PWM DRIVER

The [RPM-PWM Interface](#) contains an optional, programmable 10-bit PWM driver which can serve as part of the RPM based Fan Speed Control Algorithm or in Manual Mode.

When enabled, the PWM driver can operate in four programmable frequency bands. The lower frequency bands offer frequencies in the range of 9.5Hz to 4.8kHz while the higher frequency options offer frequencies of 21Hz or 25.2kHz.

The highest frequency available, 25.2KHz, operates in 8-bit resolution. All other PWM frequencies operate in 10-bit resolution.

35.8.5 FAN SETTING

The Fan Setting Registers are used to control the output of the Fan Driver. The driver setting operates independently of the Polarity bit for the PWM output. That is, a setting of 0000h will mean that the fan drive is at minimum drive while a value of FFC0h will mean that the fan drive is at maximum drive.

If the Spin Up Routine is invoked, reading from the registers will return the current fan drive setting that is being used by the Spin Up Routine instead of what was previously written into these registers.

The Fan Driver Setting Registers, when the RPM based Fan Control Algorithm is enabled, are read only. Writing to the register will have no effect and the data will not be stored. Reading from the register will always return the current fan drive setting.

If the INT_PWRGD pin is de-asserted, the Fan Driver Setting Register will be made read only. Writing to the register will have no effect and reading from the register will return 0000h.

When the RPM based Fan Control Algorithm is disabled, the current fan drive setting that was last used by the algorithm is retained and will be used.

If the Fan Driver Setting Register is set to a value of 0000h, all tachometer related status bits will be masked until the setting is changed. Likewise, the FAN_SHORT bit will be cleared and masked until the setting is changed.

MEC1725

The contents of the register represent the weighting of each bit in determining the final duty cycle. The output drive for a PWM output is given by the following equation:

$$\text{Drive} = (\text{FAN_SETTING_VALUE}/1023) \times 100\%$$

The PWM Divide Register determines the final PWM frequency. The base frequency set by the PWM_BASE[1:0] bits is divided by the decimal equivalent of the register settings.

The final PWM frequency is derived as the base frequency divided by the value of this register as shown in the equation below:

$$\text{PWM_Frequency} = \text{base_clk} / \text{PWM_D}$$

Where:

- base_clk = The base frequency set by the PWMx_CFG[1:0] bits
- PWM_D = the divide setting set by the PWM Divide Register.

35.8.6 ALERTS AND LIMITS

Figure 35-4, "Interrupt Flow" shows the interactions of the interrupts for fan events.

If the Fan Driver detects a drive fail, spin-up or stall event, the interrupt signal will be asserted (if enabled).

All of these interrupts can be masked from asserting the interrupt signal individually. If any bit of either Status register is set, the interrupt signal will be asserted provided that the corresponding interrupt enable bit is set accordingly.

The Status register will be updated due to an active event, regardless of the setting of the individual enable bits. Once a status bit has been set, it will remain set until the Status register bit is written to 1 (and the error condition has been removed).

If the interrupt signal is asserted, it will be cleared immediately if either the status or enable bit is cleared.

See Section 35.6, "Interrupts".

FIGURE 35-4: INTERRUPT FLOW

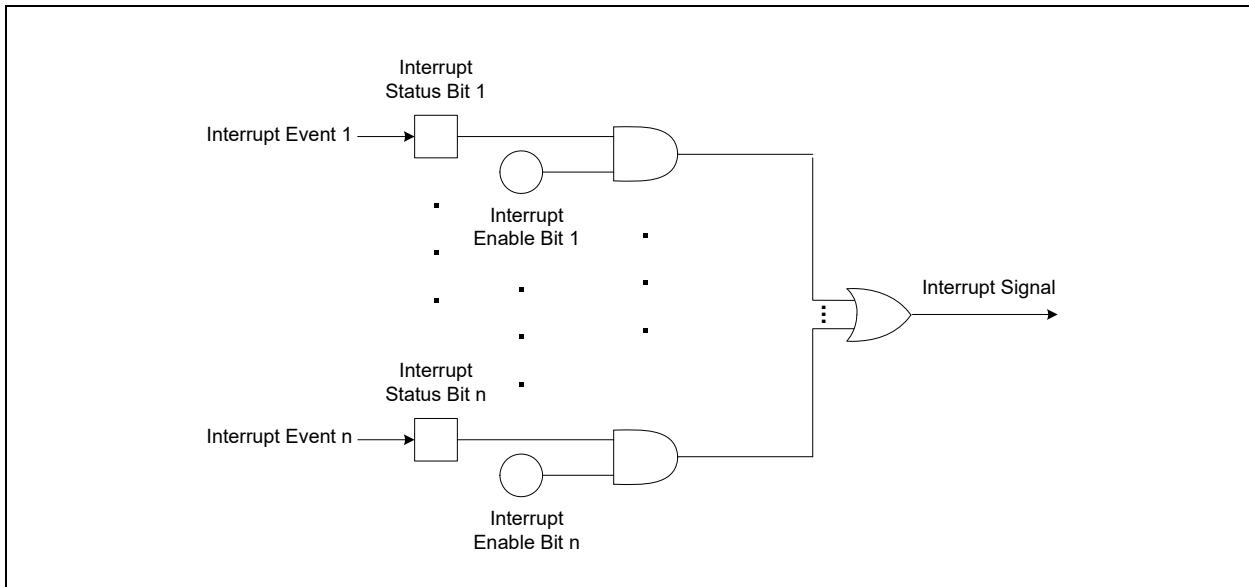

35.9 EC Registers

Registers for this block are shown in the following summary table. Addresses for each register are determined by adding the offset to the Base Address for each instance of the [RPM-PWM Interface](#) Block in the Block Overview and Base Address Table in [Section 3.0, "Device Inventory"](#).

TABLE 35-1: REGISTER SUMMARY

Offset	Register Name
00h	Fan Setting
02h	Fan Configuration Register
04h	PWM Divide Register
05h	Gain Register
06h	Fan Spin Up Configuration Register
07h	Fan Step Register
08h	Fan Minimum Drive Register
09h	Valid TACH Count Register
0Ah	Fan Drive Fail Band Register
0Ch	TACH Target Register
0Eh	TACH Reading Register
10h	PWM Driver Base Frequency Register
11h	Fan Status Register

35.9.1 FAN SETTING REGISTER

Offset	00h			
Bits	Description	Type	Default	Reset Event
15:6	FAN_SETTING The Fan Driver Setting used to control the output of the Fan Driver.	R/W	00h	RESET_SYS
5:0	Reserved	R	-	-

MEC1725

35.9.2 FAN CONFIGURATION REGISTER

Offset	02h			
Bits	Description	Type	Default	Reset Event
15	<p>EN_RRC Enables the ramp rate control circuitry during the Manual Mode of operation.</p> <p>1=The ramp rate control circuitry for the Manual Mode of operation is enabled. The PWM setting will follow the ramp rate controls as determined by the Fan Step and Update Time settings. The maximum PWM step is capped at the Fan Step setting and is updated based on the Update Time as given by the field UPDATE.</p> <p>0=The ramp rate control circuitry for the Manual Mode of operation is disabled. When the Fan Drive Setting values are changed and the RPM based Fan Control Algorithm is disabled, the fan driver will be set to the new setting immediately.</p>	R/W	0b	RESET_SYS
14	<p>DIS_GLITCH Disables the low pass glitch filter that removes high frequency noise injected on the TACH pin.</p> <p>1=The glitch filter is disabled 0=The glitch filter is enabled</p>	R/W	0b	RESET_SYS
13:12	<p>DER_OPT Control some of the advanced options that affect the derivative portion of the RPM based fan control algorithm as shown in Table 35-3, "Derivative Options". These bits only apply if the Fan Speed Control Algorithm is used.</p>	R/W	3h	RESET_SYS
11:10	<p>ERR_RNG Control some of the advanced options that affect the error window. When the measured fan speed is within the programmed error window around the target speed, the fan drive setting is not updated. These bits only apply if the Fan Speed Control Algorithm is used.</p> <p>3=200 RPM 2=100 RPM 1=50 RPM 0=0 RPM</p>	R/W	1h	RESET_SYS
9	<p>POLARITY Determines the polarity of the PWM driver. This does NOT affect the drive setting registers. A setting of 0% drive will still correspond to 0% drive independent of the polarity.</p> <p>1=The Polarity of the PWM driver is inverted. A drive setting of 00h will cause the output to be set at 100% duty cycle and a drive setting of FFh will cause the output to be set at 0% duty cycle. 0=The Polarity of the PWM driver is normal. A drive setting of 00h will cause the output to be set at 0% duty cycle and a drive setting of FFh will cause the output to be set at 100% duty cycle.</p>	R/W	0h	RESET_SYS

Offset	02h			
Bits	Description	Type	Default	Reset Event
8	Reserved	R	-	-
7	<p>EN_ALGO</p> <p>Enables the RPM based Fan Control Algorithm.</p> <p>1=The control circuitry is enabled and the Fan Driver output will be automatically updated to maintain the programmed fan speed as indicated by the TACH Target Register.</p> <p>0=The control circuitry is disabled and the fan driver output is determined by the Fan Driver Setting Register.</p>	R/W	0b	RESET_SYS
6:5	<p>RANGE</p> <p>Adjusts the range of reported and programmed tachometer reading values. The RANGE bits determine the weighting of all TACH values (including the Valid TACH Count, TACH Target, and TACH reading).</p> <p>3=Reported Minimum RPM: 4000. Tach Count Multiplier: 8</p> <p>2=Reported Minimum RPM: 2000. Tach Count Multiplier: 4</p> <p>1=Reported Minimum RPM: 1000. Tach Count Multiplier: 2</p> <p>0=Reported Minimum RPM: 500. Tach Count Multiplier: 1</p>	R/W	1h	RESET_SYS

MEC1725

Offset	02h			
Bits	Description	Type	Default	Reset Event
4:3	<p>EDGES</p> <p>Determines the minimum number of edges that must be detected on the TACH signal to determine a single rotation. A typical fan measured 5 edges (for a 2-pole fan).</p> <p>Increasing the number of edges measured with respect to the number of poles of the fan will cause the TACH Reading registers to indicate a fan speed that is higher or lower than the actual speed. In order for the FSC Algorithm to operate correctly, the TACH Target must be updated by the user to accommodate this shift. The Effective Tach Multiplier shown in Table 35-2, "Minimum Edges for Fan Rotation" is used as a direct multiplier term that is applied to the Actual RPM to achieve the Reported RPM. It should only be applied if the number of edges measured does not match the number of edges expected based on the number of poles of the fan (which is fixed for any given fan).</p> <p>Contact Microchip for recommended settings when using fans with more or less than 2 poles.</p>	R/W	1h	RESET_SYS
2:0	<p>UPDATE</p> <p>Determines the base time between fan driver updates. The Update Time, along with the Fan Step Register, is used to control the ramp rate of the drive response to provide a cleaner transition of the actual fan operation as the desired fan speed changes.</p> <p>7=1600ms 6=1200ms 5=800ms 4=500ms 3=400ms 2=300ms 1=200ms 0=100ms</p> <p>Note: This ramp rate control applies for all changes to the active PWM output including when the RPM based Fan Speed Control Algorithm is disabled.</p>	R/W	3h	RESET_SYS

TABLE 35-2: MINIMUM EDGES FOR FAN ROTATION

Edges	Minimum TACH Edges	Number of Fan Poles	Effective TACH Multiplier (Based on 2 Pole Fans) If Edges Changed
0h	3	1	0.5
1h	5	2 (default)	1
2h	7	3	1.5
3h	9	4	2

TABLE 35-3: DERIVATIVE OPTIONS

DER_OPT	Operation	Note (see Section 35.9.6, "Fan Step Register")
0	No derivative options used	PWM steps are limited to the maximum PWM drive step value in Fan Step Register
1	Basic derivative. The derivative of the error from the current drive setting and the target is added to the iterative PWM drive setting (in addition to proportional and integral terms)	PWM steps are limited to the maximum PWM drive step value in Fan Step Register
2	Step derivative. The derivative of the error from the current drive setting and the target is added to the iterative PWM drive setting and is not capped by the maximum PWM drive step. This allows for very fast response times	PWM steps are not limited to the maximum PWM drive step value in Fan Step Register (i.e., maximum fan step setting is ignored)
3	Both the basic derivative and the step derivative are used effectively causing the derivative term to have double the effect of the derivative term (default).	PWM steps are not limited to the maximum PWM drive step value in Fan Step Register (i.e., maximum fan step setting is ignored)

35.9.3 PWM DIVIDE REGISTER

Offset	04h			
Bits	Description	Type	Default	Reset Event
7:0	PWM_DIVIDE The PWM Divide value determines the final frequency of the PWM driver. The driver base frequency is divided by the PWM Divide value to determine the final frequency.	R/W	01h	RESET_SYS

35.9.4 GAIN REGISTER

The Gain Register stores the gain terms used by the proportional and integral portions of the RPM based Fan Control Algorithm. These terms will affect the FSC closed loop acquisition, overshoot, and settling as would be expected in a classic PID system.

This register only applies if the Fan Speed Control Algorithm is used.

Offset	05h			
Bits	Description	Type	Default	Reset Event
7:6	Reserved	R	-	-
5:4	GAIND The derivative gain term. Gain Factor: 3=8x 2=4x 1=2x 0=1x	R/W	2h	RESET_SYS

MEC1725

Offset	05h			
Bits	Description	Type	Default	Reset Event
3:2	<p>GAINI The integral gain term.</p> <p>Gain Factor: 3=8x 2=4x 1=2x 0=1x</p>	R/W	2h	RESET_SYS
1:0	<p>GAINP The proportional gain term.</p> <p>Gain Factor: 3=8x 2=4x 1=2x 0=1x</p>	R/W	2h	RESET_SYS

35.9.5 FAN SPIN UP CONFIGURATION REGISTER

Offset	06h			
Bits	Description	Type	Default	Reset Event
7:6	<p>DRIVE_FAIL_CNT Determines how many update cycles are used for the Drive Fail detection function. This circuitry determines whether the fan can be driven to the desired Tach target. These settings only apply if the Fan Speed Control Algorithm is enabled.</p> <p>3=Drive Fail detection circuitry will count for 64 update periods 2=Drive Fail detection circuitry will count for 32 update periods 1=Drive Fail detection circuitry will count for 16 update periods 0=Drive Fail detection circuitry is disabled</p>	R/W	00b	RESET_SYS
5	<p>NOKICK Determines if the Spin Up Routine will drive the fan to 100% duty cycle for 1/4 of the programmed spin up time before driving it at the programmed level.</p> <p>1=The Spin Up Routine will not drive the PWM to 100%. It will set the drive at the programmed spin level for the entire duration of the programmed spin up time 0=The Spin Up Routine will drive the PWM to 100% for 1/4 of the programmed spin up time before reverting to the programmed spin level</p>	R/W	0b	RESET_SYS

Offset	06h			
Bits	Description	Type	Default	Reset Event
4:2	<p>SPIN_LVL</p> <p>Determines the final drive level that is used by the Spin Up Routine.</p> <p>7=65% 6=60% 5=55% 4=50% 3=45% 2=40% 1=35% 0=30%</p>	R/W	6h	RESET_SYS
1:0	<p>SPINUP_TIME</p> <p>Determines the maximum Spin Time that the Spin Up Routine will run for. If a valid tachometer measurement is not detected before the Spin Time has elapsed, an interrupt will be generated. When the RPM based Fan Control Algorithm is active, the fan driver will attempt to re-start the fan immediately after the end of the last spin up attempt.</p> <p>3=2 seconds 2=1 second 1=500 ms 0=250 ms</p>	R/W	1h	RESET_SYS

35.9.6 FAN STEP REGISTER

The Fan Step Register, along with the Update Time, controls the ramp rate of the fan driver response calculated by the RPM based Fan Control Algorithm for the Derivative Options field values of “00” and “01” in the [Fan Configuration Register](#).

The value of the register represents the maximum step size the fan driver will take for each update.

When the maximum step size limitation is applied, if the necessary fan driver delta is larger than the Fan Step, it will be capped at the Fan Step setting and updated every Update Time ms.

The maximum step size is ignored for the Derivative Options field values of “10” and “11”.

Offset	07h			
Bits	Description	Type	Default	Reset Event
7:0	<p>FAN_STEP</p> <p>The Fan Step value represents the maximum step size the fan driver will take between update times.</p> <p>When the PWM_BASE frequency range field in the PWM Driver Base Frequency Register is set to the value 1, 2 or 3, this 8-bit field is added to the 10-bit PWM duty cycle, for a maximum step size of 25%. When the PWM_BASE field is set to 0, the PWM operates in an 8-bit mode. In 8-bit mode, this 8-bit field is added to the 8-bit duty cycle, for a maximum step size of 100%.</p>	R/W	10h	RESET_SYS

MEC1725

35.9.7 FAN MINIMUM DRIVE REGISTER

the Fan Minimum Drive Register stores the minimum drive setting for the RPM based Fan Control Algorithm. The RPM based Fan Control Algorithm will not drive the fan at a level lower than the minimum drive unless the target Fan Speed is set at FFh (see "TACH Target Registers").

During normal operation, if the fan stops for any reason (including low drive), the RPM based Fan Control Algorithm will attempt to restart the fan. Setting the Fan Minimum Drive Registers to a setting that will maintain fan operation is a useful way to avoid potential fan oscillations as the control circuitry attempts to drive it at a level that cannot support fan operation.

These registers only apply if the Fan Speed Control Algorithm is used.

Offset	08h			
Bits	Description	Type	Default	Reset Event
7:0	MIN_DRIVE The minimum drive setting.	R/W	66h	RESET_SYS

Note: To ensure proper operation, the Fan Minimum Drive register must be set prior to setting the Tach Target High and Low Byte registers, and then the Tach Target registers can be subsequently updated. At a later time, if the Fan Minimum Drive register is changed to a value higher than current Fan value, the Tach Target registers must also be updated.

35.9.8 VALID TACH COUNT REGISTER

The Valid TACH Count Register stores the maximum TACH Reading Register value to indicate that the fan is spinning properly. The value is referenced at the end of the Spin Up Routine to determine if the fan has started operating and decide if the device needs to retry. See the equation in the TACH Reading Registers section for translating the RPM to a count.

If the TACH Reading Register value exceeds the Valid TACH Count Register (indicating that the Fan RPM is below the threshold set by this count), a stalled fan is detected. In this condition, the algorithm will automatically begin its Spin Up Routine.

Note: The automatic invoking of the Spin Up Routine only applies if the Fan Speed Control Algorithm is used. If the FSC is disabled, then the device will only invoke the Spin Up Routine when the PWM setting changes from 00h.

If a TACH Target setting is set above the Valid TACH Count setting, that setting will be ignored and the algorithm will use the current fan drive setting.

These registers only apply if the Fan Speed Control Algorithm is used.

Offset	09h			
Bits	Description	Type	Default	Reset Event
7:0	VALID_TACH_CNT The maximum TACH Reading Register value to indicate that the fan is spinning properly.	R/W	F5h	RESET_SYS

35.9.9 FAN DRIVE FAIL BAND REGISTER

The Fan Drive Fail Band Registers store the number of Tach counts used by the Fan Drive Fail detection circuitry. This circuitry is activated when the fan drive setting high byte is at FFh. When it is enabled, the actual measured fan speed is compared against the target fan speed.

This circuitry is used to indicate that the target fan speed at full drive is higher than the fan is actually capable of reaching. If the measured fan speed does not exceed the target fan speed minus the Fan Drive Fail Band Register settings for a period of time longer than set by the DRIVE_FAIL_CNTx[1:0] bits in the [Fan Spin Up Configuration Register](#), the DRIVE_FAIL status bit will be set and an interrupt generated.

These registers only apply if the Fan Speed Control Algorithm is used.

Offset	0Ah			
Bits	Description	Type	Default	Reset Event
15:3	FAN_DRIVE_FAIL_BAND The number of Tach counts used by the Fan Drive Fail detection circuitry	R	0h	RESET_SYS
2:0	Reserved	R	-	-

35.9.10 TACH TARGET REGISTER

The TACH Target Registers hold the target tachometer value that is maintained for the RPM based Fan Control Algorithm.

If the algorithm is enabled, setting the TACH Target Register High Byte to FFh will disable the fan driver (or set the PWM duty cycle to 0%). Setting the TACH Target to any other value (from a setting of FFh) will cause the algorithm to invoke the Spin Up Routine after which it will function normally.

These registers only apply if the Fan Speed Control Algorithm is used.

Offset	0Ch			
Bits	Description	Type	Default	Reset Event
15:3	TACH_TARGET The target tachometer value.	R	-	RESET_SYS
2:0	Reserved	R	-	-

MEC1725

35.9.11 TACH READING REGISTER

The TACH Reading Registers' contents describe the current tachometer reading for the fan. By default, the data represents the fan speed as the number of 32.768kHz clock periods that occur for a single revolution of the fan.

The Equation below shows the detailed conversion from tachometer measurement (COUNT) to RPM.

$$RPM = \frac{1}{Poles} \times \frac{(n-1)}{COUNT \times \frac{1}{m}} \times f_{TACH} \times 60$$

where:

- *Poles* = number of poles of the fan (typically 2)
- f_{TACH} = the frequency of the tachometer measurement clock
- *n* = number of edges measured (typically 5 for a 2 pole fan)
- *m* = the multiplier defined by the RANGE bits
- *COUNT* = TACH Reading Register value (in decimal)

The following equation shows the simplified translation of the TACH Reading Register count to RPM assuming a 2-pole fan, measuring 5 edges, with a frequency of 32.768kHz.

$$RPM = \frac{3932160 \times m}{COUNT}$$

Offset	0Eh			
Bits	Description	Type	Default	Reset Event
15:3	TACH_READING The current tachometer reading value.	R	-	RESET_SYS
2:0	Reserved	R	-	-

35.9.12 PWM DRIVER BASE FREQUENCY REGISTER

Offset	10h			
Bits	Description	Type	Default	Reset Event
7:2	Reserved	R	-	-
1:0	PWM_BASE Determines the frequency range of the PWM fan driver (when enabled). PWM resolution is 10-bit, except when this field is set to '0b', when it is 8-bit. 3=2.34KHz 2=4.67KHz 1=23.4KHz 0=26.8KHz	R/W	00b	RESET_SYS

35.9.13 FAN STATUS REGISTER

Offset	11h			
Bits	Description	Type	Default	Reset Event
7:6	Reserved	R	-	-
5	<p>DRIVE_FAIL</p> <p>The bit Indicates that the RPM-based Fan Speed Control Algorithm cannot drive the Fan to the desired target setting at maximum drive.</p> <p>1=The RPM-based Fan Speed Control Algorithm cannot drive Fan to the desired target setting at maximum drive. 0=The RPM-based Fan Speed Control Algorithm can drive Fan to the desired target setting.</p>	R/WC	0b	RESET_SYS
4:2	Reserved	R	-	-
1	<p>FAN_SPIN</p> <p>The bit Indicates that the Spin up Routine for the Fan could not detect a valid tachometer reading within its maximum time window.</p> <p>1=The Spin up Routine for the Fan could not detect a valid tachometer reading within its maximum time window. 0=The Spin up Routine for the Fan detected a valid tachometer reading within its maximum time window.</p>	R/WC	0b	RESET_SYS
0	<p>FAN_STALL</p> <p>The bit Indicates that the tachometer measurement on the Fan detects a stalled fan.</p> <p>1=Stalled fan not detected 0=Stalled fan not detected</p>	R/WC	0b	RESET_SYS

35.10 Usage Models

The example below explains the usage/ register programming of this block for a 2 pole Fan with RPM value less than 500.

Example

Most fans are two pole and thus require 5 edges to calculate one revolution. In cases where you need a minimum fan speed of less than 500 RPM, 3 edges can be used to measure half of a revolution. This allows for a lower fan speed before a Tach reaches its end count.

The equation for determining RPM as function of Tach count when the proper edge selection is done is given below:

$$\text{RPM} = (392160 * M) / \text{count}$$

When 3 edges is chosen instead of 5 edge for a 2 pole fan, the RPM equation is as follows:

$$\text{RPM} = (392160 * M) / (\text{count} * 2)$$

MEC1725

When 3 edges instead of 5 edges are used to determine fan speed, the modified equation must be used for calculating and programming [TACH Target Register](#) and [Valid TACH Count Register](#) or reading from [TACH Reading Register](#) to determine appropriate fan speed. This would require software that use the [TACH Reading Register](#) to use the new equation mentioned above to display the fan speed properly.

Note: The [Valid TACH Count Register](#) is a 8 bit register instead of a 13 bit. These 8 bits should be treated as the upper 8 bits of a 13 bit count value.

36.0 KEYBOARD SCAN INTERFACE

36.1 Overview

The Keyboard Scan Interface block provides a register interface to the EC to directly scan an external keyboard matrix of size up to 18x8.

The maximum configuration of the Keyboard Scan Interface is 18 outputs by 8 inputs. For a smaller matrix size, firmware should configure unused KSO pins as GPIOs or another alternate function, and it should mask out unused KSIs and associated interrupts.

36.2 References

No references have been cited for this feature.

36.3 Terminology

There is no terminology defined for this section.

36.4 Interface

This block is designed to be accessed externally via the pin interface and internally via a registered host interface.

FIGURE 36-1: I/O DIAGRAM OF BLOCK

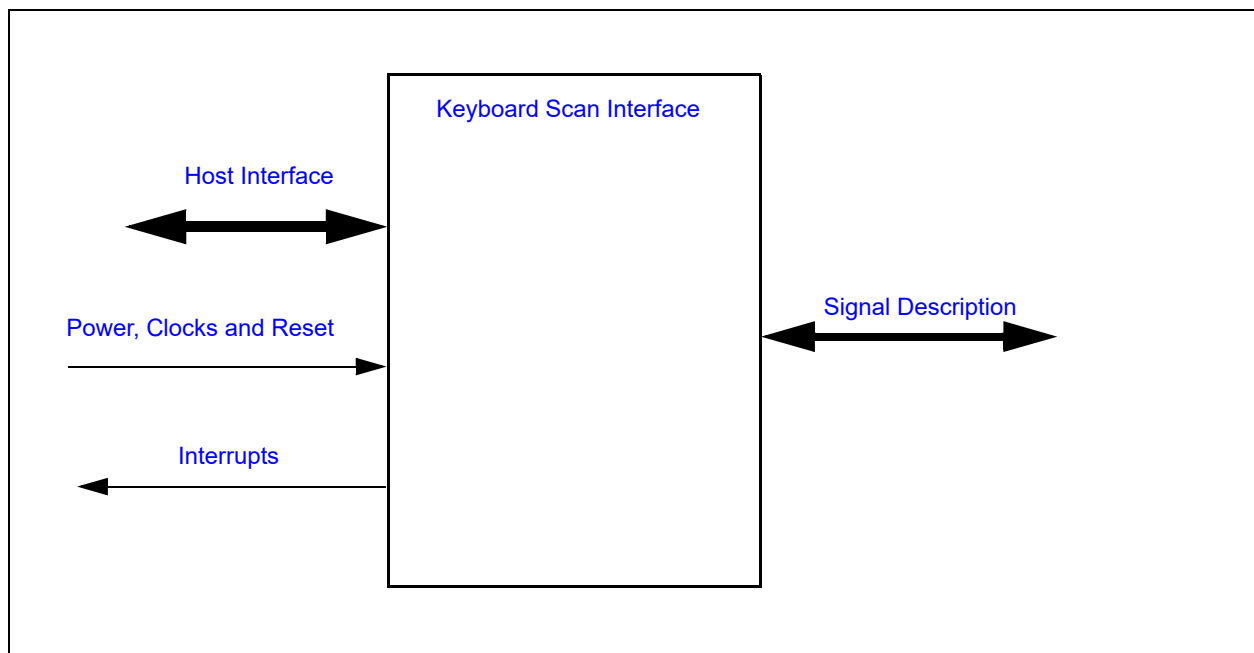

36.5 Signal Description

Name	Direction	Description
KSI[7:0]	Input	Column inputs from external keyboard matrix.
KSO[17:0]	Output	Row outputs to external keyboard matrix.

MEC1725

36.6 Host Interface

The registers defined for the Keyboard Scan Interface are accessible by the various hosts as indicated in [Section 3.2, "Block Overview and Base Addresses"](#).

36.7 Power, Clocks and Reset

This section defines the Power, Clock, and Reset parameters of the block.

36.7.1 POWER DOMAINS

Name	Description
VTR_CORE	The logic and registers implemented in this block are powered by this power well.

36.7.2 CLOCK INPUTS

Name	Description
48MHz	This is the clock source for Keyboard Scan Interface logic.

36.7.3 RESETS

Name	Description
RESET_SYS	This signal resets all the registers and logic in this block to their default state.

36.8 Interrupts

This section defines the Interrupt Sources generated from this block.

Source	Description
KSC_INT	Wake capable Interrupt request to the Interrupt Aggregator.

36.9 Low Power Modes

The Keyboard Scan Interface automatically enters a low power mode whenever it is not actively scanning the keyboard matrix. The block is also placed in a low-power state when it is disabled by the [KSEN](#) bit. When the interface is in a low-power mode it will not prevent the chip from entering a sleep state. When the interface is active it will inhibit the chip sleep state until the interface has re-entered its low power mode.

36.10 Description

FIGURE 36-2: KEYBOARD SCAN INTERFACE BLOCK DIAGRAM

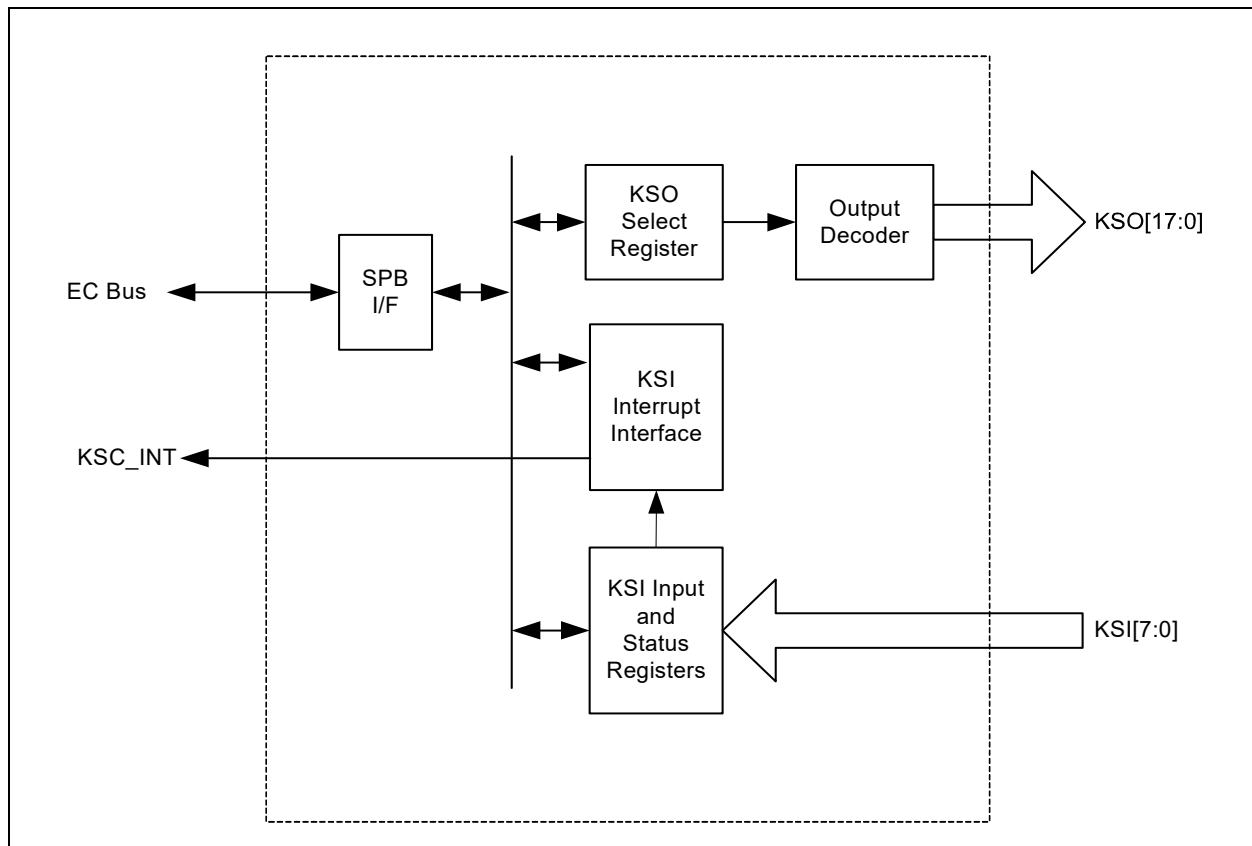

During scanning the firmware sequentially drives low one of the rows (KSO[17:0]) and then reads the column data line (KSI[7:0]). A key press is detected as a zero in the corresponding position in the matrix. Keys that are pressed are debounced by firmware. Once confirmed, the corresponding keycode is loaded into host data read buffer in the 8042 Host Interface module. Firmware may need to buffer keycodes in memory in case this interface is stalled or the host requests a Resend.

36.10.1 INITIALIZATION OF KSO PINS

If the Keyboard Scan Interface is not configured for PREDRIVE Mode, KSO pins should be configured as open-drain outputs. Internal or external pull-ups should be used so that the GPIO functions that share the pins do not have a floating input when the KSO pins are tri-stated.

If the Keyboard Scan Interface is configured for PREDRIVE Mode, KSO pins must be configured as push-pull outputs. Internal or external pull-ups should be used to protect the GPIO inputs associated with the KSO pins from floating inputs.

36.10.2 PREDRIVE MODE

There is an optional Predrive Mode that can be enabled to actively drive the KSO pins high before switching to open-drain operation. The PREDRIVE ENABLE bit in the [Keyscan Extended Control Register](#) is used to enable the PREDRIVE option. Timing for the Predrive mode is shown in [Section 53.12, Keyboard Scan Matrix Timing](#).

36.10.2.1 Predrive Mode Programming

The following precautions should be taken to prevent output pad damage during [Predrive Mode Programming](#).

MEC1725

36.10.2.2 Asserting PREDRIVE_ENABLE

1. Disable Key Scan Interface (KSEN = '1')
2. Enable Predrive function (PREDRIVE_ENABLE = '1')
3. Program buffer type for all KSO pins to "push-pull"
4. Enable Keyscan Interface (KSEN = '0')

36.10.2.3 De-asserting PREDRIVE_ENABLE

1. Disable Key Scan Interface (KSEN = '1')
2. Program buffer type for all KSO pins to "open-drain"
3. Disable Predrive function (PREDRIVE_ENABLE = '0')
4. Enable Keyscan Interface (KSEN = '0')

36.10.3 INTERRUPT GENERATION

To support interrupt-based processing, an interrupt can optionally be generated on the high-to-low transition on any of the KSI inputs. A running clock is not required to generate interrupts.

36.10.3.1 Runtime interrupt

[KSC_INT](#) is the block's runtime active-high level interrupt. It is connected to the interrupt interface of the Interrupt Aggregator, which then relays interrupts to the EC.

Associated with each KSI input is a status register bit and an interrupt enable register bit. A status bit is set when the associated KSI input goes from high to low. If the interrupt enable bit for that input is set, an interrupt is generated. An interrupt is de-asserted when the status bit and/or interrupt enable bit is clear. A status bit cleared when written to a '1'.

Interrupts from individual KSIs are logically ORed together to drive the [KSC_INT](#) output port. Once asserted, an interrupt is not asserted again until either all [KSI\[7:0\]](#) inputs have returned high or the [KSC_INT](#) has changed.

36.10.4 WAKE PROGRAMMING

Using the Keyboard Scan Interface to 'wake' the MEC1725 can be accomplished using either the Keyboard Scan Interface wake interrupt, or using the wake capabilities of the GPIO Interface pins that are multiplexed with the Keyboard Scan Interface pins. Enabling the Keyboard Scan Interface wake interrupt requires only a single interrupt enable access and is recommended over using the GPIO Interface for this purpose.

36.11 EC Registers

Registers for this block are shown in the following summary table. Addresses for each register are determined by adding the offset to the Base Address for each instance of the [Keyboard Scan Interface](#) Block in the Block Overview and Base Address Table in [Section 3.0, "Device Inventory"](#).

TABLE 36-1: EC-ONLY REGISTER SUMMARY

Offset	Register Name
0h	Reserved
4h	KSO Select Register
8h	KSI INPUT Register
Ch	KSI STATUS Register
10h	KSI INTERRUPT ENABLE Register
14h	Keyscan Extended Control Register

36.11.1 KSO SELECT REGISTER

Offset	04h			
Bits	Description	Type	Default	Reset Event
31:4	Reserved	RES	-	-
7	KSO_INVERT This bit controls the output level of KSO pins when selected. 0=KSO[x] driven low when selected 1=KSO[x] driven high when selected.	R/W	0h	RESET_SYS
6	KSEN This field enables and disables keyboard scan 0=Keyboard scan enabled 1=Keyboard scan disabled. All KSO output buffers disabled.	R/W	1h	RESET_SYS
5	KSO_ALL 0=When key scan is enabled, KSO output controlled by the KSO_SELECT field. 1=KSO[x] driven high when selected.	R/W	0h	RESET_SYS
4:0	KSO_SELECT This field selects a KSO line (00000b = KSO[0] etc.) for output according to the value off KSO_INVERT in this register. See Table 36-2, "KSO Select Decode"	R/W	0h	RESET_SYS

TABLE 36-2: KSO SELECT DECODE

KSO Select [4:0]	KSO Selected
00h	KSO00
01h	KSO01
02h	KSO02
03h	KSO03
04h	KSO04
05h	KSO05
06h	KSO06
07h	KSO07
08h	KSO08
09h	KSO09
0Ah	KSO10
0Bh	KSO11
0Ch	KSO12
0Dh	KSO13
0Eh	KSO14
0Fh	KSO15

MEC1725

TABLE 36-2: KSO SELECT DECODE (CONTINUED)

KSO Select [4:0]	KSO Selected
10h	KSO16
11h	KSO17

TABLE 36-3: KEYBOARD SCAN OUT CONTROL SUMMARY

KSO_INVERTt	KSEN	KSO_ALL	KSO_SELECT	Description
X	1	x	x	Keyboard Scan disabled. KSO[17:0] output buffers disabled.
0	0	0	10001b-00000b	KSO[Drive Selected] driven low. All others driven high
1	0	0	10001b-00000b	KSO[Drive Selected] driven high. All others driven low
0	0	0	11111b-10010b	All KSO's driven high
1	0	0	11111b-10010b	All KSO's driven low
0	0	1	x	All KSO's driven high
1	0	1	x	All KSO's driven low

36.11.2 KSI INPUT REGISTER

Offset	08h			
Bits	Description	Type	Default	Reset Event
31:8	Reserved	RES	-	-
7:0	KSI This field returns the current state of the KSI pins.	R	0h	RESET_SYS

36.11.3 KSI STATUS REGISTER

Offset	0Ch			
Bits	Description	Type	Default	Reset Event
31:8	Reserved	RES	-	-
7:0	KSI_STATUS Each bit in this field is set on the falling edge of the corresponding KSI input pin. A KSI interrupt is generated when its corresponding status bit and interrupt enable bit are both set. KSI interrupts are logically ORed together to produce KSC_INT . Writing a '1' to a bit will clear it. Writing a '0' to a bit has no effect.	R/WC	0h	RESET_SYS

36.11.4 KSI INTERRUPT ENABLE REGISTER

Offset	10h			
Bits	Description	Type	Default	Reset Event
31:8	Reserved	RES	-	-
7:0	KSI_INT_EN Each bit in KSI_INT_EN enables interrupt generation due to high-to-low transition on a KSI input. An interrupt is generated when the corresponding bits in KSI_STATUS and KSI_INT_EN are both set.	R/W	0h	RESET_SYS

36.11.5 KEYSKAN EXTENDED CONTROL REGISTER

Offset	14h			
Bits	Description	Type	Default	Reset Event
32:1	Reserved	RES	-	-
0	PREDRIVE_ENABLE PREDRIVE_ENABLE enables the PREDRIVE mode to actively drive the KSO pins high for two 96 MHz clocks before switching to open-drain operation. 0=Disable predrive on KSO pins 1=Enable predrive on KSO pins.	R/W	0h	RESET_SYS

37.0 ENVIRONMENTAL MONITOR

37.1 Introduction

The [Environmental Monitor](#) block is a combination temperature sensor, voltage monitor, and hardware set thermal monitor and fan controller. It monitors one internal diode and four external diodes, or eight external diodes if anti-parallel diodes are used. It monitors three external voltage channels (including VSET), plus the VTR supply.

The [Environmental Monitor](#) acts as an always on thermal monitor to signal a system wide interrupt should the CPU temperature exceed a hardware set limit that cannot be altered via software. It also contains a VBAT Power Domain ThermTrip Status register to identify which inputs have caused the SYS_SHDN# signal to be asserted.

37.2 References

1. "Using Anti-Parallel Diode (APD) with Microchip Temperature Sensors", Application Note 16.4, Microchip Technology

37.3 Terminology

There is no terminology defined for this chapter.

37.4 Interface

This block is designed to be accessed externally via the pin interface and internally via a registered host interface.

The registers in the block are accessed by embedded controller code at the addresses shown in and [Section 37.10](#), "[Environmental Monitor Register Bank](#)".

37.4.1 ENVIRONMENTAL MONITOR SIGNAL TO PIN MAPPING

The [Environmental Monitor Signal to Pin Mapping](#) Table maps the pins to the signals that are routed to/from the [Environmental Monitor](#) block.

TABLE 37-1: ENVIRONMENTAL MONITOR SIGNAL TO PIN MAPPING

Pin Name	ENV MON Signal	ENV MON Direction	Description
VCI_IN0#	SYS_SHDN_RST1#	Input	SYS_SHDN_RST1# is an active low reset for the ThermTrip logic output, SYS_SHDN#. VCI_IN0# is combined with the VCI_IN1# pin to create the SYS_SHDN_RST1# signal to the Environmental Monitor block.
VCI_IN1#	SYS_SHDN_RST1#	Input	SYS_SHDN_RST1# is an active low reset for the ThermTrip logic output, SYS_SHDN#. VCI_IN1# is combined with the VCI_IN0# pin to create the SYS_SHDN_RST1# signal to the Environmental Monitor block.
VCI_OVRD_IN	SYS_SHDN_RST2	Input	SYS_SHDN_RST2 is an active high reset for ThermTrip logic output, SYS_SHDN#. VCI_OVRD_IN is used as the SYS_SHDN_RST2 signal to the Environmental Monitor block.
VCI_OUT	SYS_SHDN#	Output	SYS_SHDN# is the Active low output from the ThermTrip logic in the Environmental Monitor block. This signal is routed into the VBAT Powered Control Logic to assert the VCI_OUT pin.
VTR_ANALOG	VTR	Input	The VTR voltage input in the Environmental Monitor block monitors VTR_ANALOG .
RESET_VCC	PWRGD_IN	Input	PWRGD_IN is the active high powergood input to the Environmental Monitor block that is derived from RESET_VCC .

37.4.2 ENVIRONMENTAL MONITOR SIGNALS

The [Environmental Monitor Signal Description Table](#) lists the signals that are routed to/from the block.

TABLE 37-2: Environmental Monitor SIGNAL DESCRIPTION TABLE

Name	Direction	Description
SYS_SHDN_RST1#	Input	Active low reset for ThermTrip logic output
SYS_SHDN_RST2#	Input	Active high reset for ThermTrip logic output
SYS_SHDN#	Output	Active low output from ThermTrip logic
DN1_DP1A /THERM1	Analog Input/Output	DN1 - External Diode 1 negative (cathode) connection DP1A - External Diode 1A positive (anode) connection when APD enabled THERM1 - Thermistor 1 measurement input
DP1_DN1A /VREF_T1	Analog Input/Output	DP1 - External Diode 1 positive (anode) connection DN1A - External Diode 1A negative (cathode) connection when APD enabled VREF_T1 - Thermistor 1 reference voltage output
DN2_DP2A /THERM2	Analog Input/Output	DN2 - External Diode 2 negative (cathode) connection DP2A - External Diode 2A positive (anode) connection when APD enabled THERM2 - Thermistor 2 measurement input
DP2_DN2A /VREF_T2	Analog Input/Output	DP2 - External Diode 2 positive (anode) connection DN2A - External Diode 2A negative (cathode) connection when APD enabled VREF_T2 - Thermistor 2 reference voltage output
DN3_DP3A /THERM3	Analog Input/Output	DN3 - External Diode 3 negative (cathode) connection DP3A - External Diode 3A positive (anode) connection when APD enabled THERM3 - Thermistor 3 measurement input
DP3_DN3A /VREF_T3	Analog Input/Output	DP3 - External Diode 3 positive (anode) connection DN3A - External Diode 3A negative (cathode) connection when APD enabled VREF_T3 - Thermistor 3 reference voltage output
DN4_DP4A /THERM3	Analog Input/Output	DN4 - External Diode 4 negative (cathode) connection DP3A - External Diode 4A positive (anode) connection when APD enabled THERM3 - Thermistor 4 measurement input
DP4_DN4A /VREF_T4	Analog Input/Output	DP4 - External Diode 4 positive (anode) connection DN4A - External Diode 4A negative (cathode) connection when APD enabled VREF_T4 - Thermistor 4 reference voltage output
VIN	Analog Input/Output	Voltage input for VIN
VSET	Analog Input	Voltage input to set hardware failsafe temperature threshold
VTT	Analog Input	Voltage input for VTT
VTR	Analog Input	Voltage input for VTR

MEC1725

TABLE 37-3: Environmental Monitor INTERNAL SIGNAL TABLE

Name	Description
PWRGD_IN	This signal indicates that the main system power supply is operational. It is asserted when the RESET_VCC reset signal is de-asserted.
HW_FAILSAFE#	This signal indicate an over-temperature condition exists. Used internally in the block.
SYS_SHDN_RST	Active high reset for ThermTrip logic, from the SYS_SHDN_RST bit in the System Shutdown Reset Register .

37.4.3 UNUSED DIODE PINS

If a Diode is not used, then place a resistor between the Diode pins as shown in [Figure 37-1](#).

FIGURE 37-1: UNUSED DIODE PIN CONNECTION

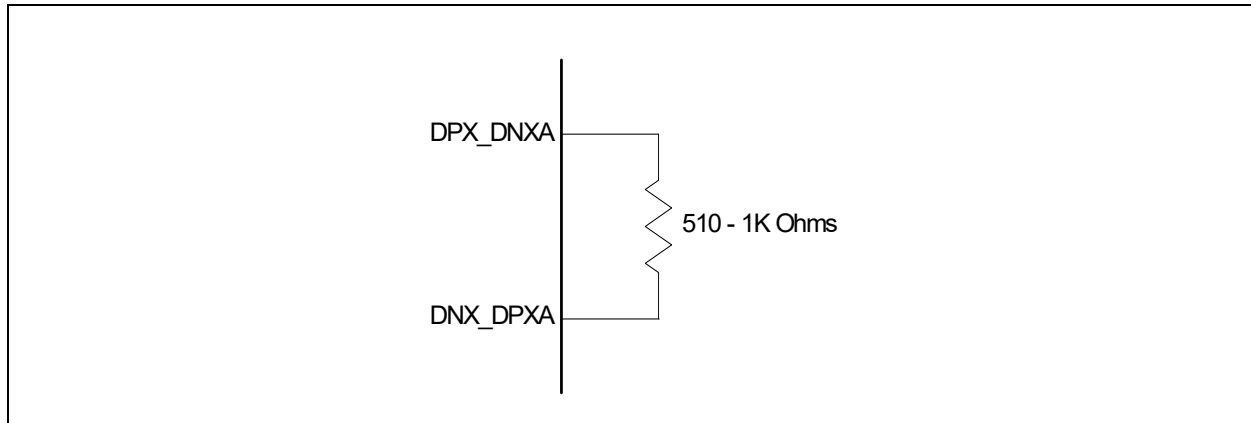

TABLE 37-4: UNUSED DIODE CURRENT

Diode Selected For Temperature Conversion	MIN	MAX	Unit
No	–	4	μA
Yes	100	350	

37.5 Power, Clocks and Reset

This section defines the Power, Clock, and Reset parameters of the block.

37.5.1 POWER DOMAINS

TABLE 37-5: POWER SOURCES

Name	Description
VTR_ANALOG	This power well sources all of the registers and logic in this block, except where noted.
VTR_ANALOG	This power well sources the analog components of this block. These bit fields are identified in the register descriptions.

TABLE 37-5: POWER SOURCES (CONTINUED)

Name	Description
VBAT	This power well sources selected bit fields in the registers implemented in this block. These bit fields are identified in the register descriptions.

37.5.2 CLOCK INPUTS

TABLE 37-6: CLOCK INPUTS

Name	Description
48MHz	This clock signal drives selected logic (e.g., counters).
32KHz Core	The 32KHz clock domain provides clocking for Conversion Cycles and to reset the SYS_SHDN# output. The 32KHz clock domain must be operational in order for the Environmental Monitor to operate.

37.5.3 RESETS

TABLE 37-7: RESET SIGNALS

Name	Description
RESET_SYS	This reset signal resets all of the registers and logic in this block. RESET_SYS is the VTR Reset.
RESET_VBAT	This reset signal reset selected bit fields in the registers implemented in this block. These bit fields are identified in the register descriptions. RESET_VBAT is the VBAT Reset.
RESET_VCC	This signal indicates the main power supply is available when it is high (that is, when this reset is de-asserted).

37.5.4 POWERGOOD SIGNALS

TABLE 37-8: POWERGOOD SIGNALS

Name	Description
RESET_VTR	This signal indicates that the VTR_ANALOG supply is fully powered.

MEC1725

37.5.5 POWER MANAGEMENT

TABLE 37-9: ENVIRONMENTAL MONITOR OPERATION

LPM (Note 1)	PWRGD_IN	Channel Enables	Idle	Description
1	X	Any Channel Enabled	0	The ENV MON is in run mode whenever any monitoring channel is enabled and the LPM bit is '1,' or whenever the LPM bit is '0' and PWRGD_IN is asserted.
0	1			
	0	All Channels Disabled	1	The ENV MON is in idle mode whenever any monitoring channel is enabled and the LPM bit is '0' and PWRGD_IN is <i>not</i> asserted, or whenever all monitoring channels are disabled. The block will enter heavy a sleep state when it is idle.
X	X			

Note 1: The LPM bit is bit 0 in the FailSafe Configuration Register

See [Section 37.9.4, "Power Modes,"](#) on page 511.

See also the CONV<1:0> bits in the [Temperature Conversion Rate Configuration Register](#).

37.6 Host Interface

The registers defined for the General Purpose Serial Peripheral Interface are accessible by the various hosts as indicated in [Section 37.10, "Environmental Monitor Register Bank"](#).

37.7 Interrupts

This section defines the Interrupt Sources generated from this block.

Source	Description
ENVMON	The event status interrupt is the OR of the enabled temp, therm and volt events from the Interrupt status/enable registers. It is routed to the Interrupt Controller.

37.8 Low Power Modes

The [Environmental Monitor](#) may be put into a low power state by the chip's Power, Clocks, and Reset (PCR) circuitry.

37.9 Description

This section defines the functionality of the block.

[Figure 37-2](#) illustrates the [Environmental Monitor](#) block and shows the sub-blocks and interface signals to the block.

FIGURE 37-2: ENVIRONMENTAL MONITOR DIAGRAM

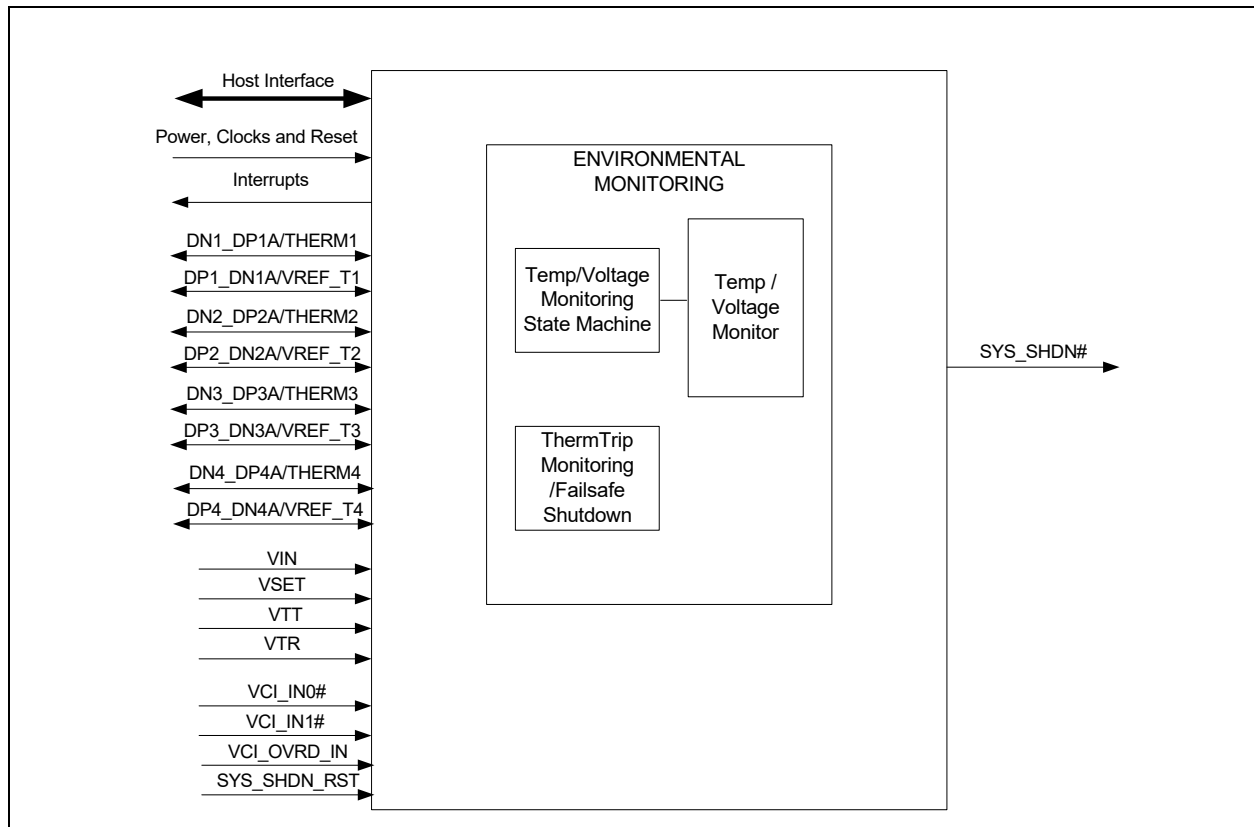

37.9.1 GENERAL OPERATION

The **Environmental Monitor** is a combination temperature sensor, voltage and thermal monitor device. The **Environmental Monitor** monitors up to four (4) external diodes, or eight external diodes if anti-parallel diodes are used, and up to four (4) voltage channels. The **Environmental Monitor** also acts as an always on thermal monitor to signal a system wide interrupt should the CPU temperature exceed a hardware set limit that cannot be altered via software. This ThermTrip logic uses signals from other external devices to determine overall system operation.

37.9.2 CONVERSION CYCLES

The **Environmental Monitor** monitors up to eight (8) temperature channels (not including internal diode) in addition to four (4) voltage channels. All of these measurements are performed in a round-robin loop.

Monitoring is active as shown in as shown in [Table 37-10](#). In addition, the chip samples the VSET voltage on the first monitoring conversion cycle following **RESET_SYS**. See also [Section 37.9.9, "Voltage Programmable Fail-Safe Temperature Monitor"](#).

TABLE 37-10: MONITORING

RESET_VTR	PWRGD_IN	LPM (Note 1)	Monitoring
0	0	0	No
1	0	0	No

TABLE 37-10: MONITORING (CONTINUED)

RESET_VTR	PWRGD_IN	LPM (Note 1)	Monitoring
1	0	1	Yes
1	1	x	Yes

Note 1: The LPM bit is in the FailSafe Configuration Register.

Whenever the monitoring is disabled and restarted, the cycle starts from the beginning.

TABLE 37-11: CONVERSION CHANNEL ORDER

Order	Channel	Stored Resolution
1	Internal Diode	9-bit
2	External Diode 1	12-bit
	Thermistor 1 (if enabled)	8-bit
3	External Diode 2	12-bit
	Thermistor 2 (if enabled)	8-bit
4	External Diode 3	12-bit
	Thermistor 3 (if enabled)	8-bit
5	External Diode 4	12-bit
	Thermistor 4 (if enabled)	8-bit
6	External Diode 1A (if enabled)	12-bit
7	External Diode 2A (if enabled)	12-bit
8	External Diode 3A (if enabled)	12-bit
9	External Diode 4A (if enabled)	12-bit
10	VIN	8-bit
11	VTR	8-bit
12	VTT	8-bit
13	VSET	8-bit

If no channels are enabled, a conversion cycle will take less than 1 μ S.

37.9.3 PROCEDURE FOR MULTI-SECOND WAKE INTERRUPT EVENT

The ENVMON interrupt bit is a wake-capable interrupt event that is triggered by the CONV CNT DONE status bit. Here is the recommended procedure for generating a wakeup interrupt event when the Conversion Rate Mode is configured for Multi-Second Rate Conversions.

1. Set Conversion rate to 1 second in the Temperature Conversion Config. Register, offset 2Fh, field CONV, bits[1:0]
2. Set the desired conversion rate in the Conversion Seconds Rate Register, offset 6Ch, field Conversion Seconds Rate, bits [4:0]
3. Set CONV CNT DONE field to 1 in the Volt Interrupt Enable Register, offset 7Eh, bit 4.

4. Set the Conversion Rate Mode to Multi-Second Rate by setting the field, bit[0] in the Conversion Mode Register, offset 6Eh, to 1
5. Put Embedded Controller to sleep
6. <sleep>
7. After the timer expires, an interrupt occurs and the Embedded Controller is awakened
8. <Customer Actions, if required>
9. Force a conversion by setting the Conversion Force field, bit[1] in the Conversion Mode Register, offset 6Eh, to 1
10. Go to step 5

37.9.4 POWER MODES

The [Environmental Monitor](#) has three power modes:

- Run. In this mode, the block performs all the enabled temperature and voltage measurements listed in [Table 37-11, "Conversion Channel Order"](#).
- Idle. In this mode, the block is in a low power state. The [Environmental Monitor](#) block does not require a clock and it will enter a heavy sleep state while the [Environmental Monitor](#) is in the Idle state. The block will remain in this sleep state until it needs to perform a Conversion Cycle.
- VBAT Power. In this mode, VTR power has been removed, and all logic in the block except the ThermTrip logic is disabled. The ThermTrip logic remains powered but cannot be updated.

The block transitions from the Run state to the Idle state when the Conversion Cycle described in [Section 37.9.2, "Conversion Cycles"](#) completes, unless all the following conditions are true:

- The [Temperature Conversion Rate Configuration Register](#) is set to Continuous operation
- Either the [PWRGD_IN](#) signal or the [LPM](#) bit are asserted

If the [Environmental Monitor](#) does not transition to the Idle state, it will remain in the Run state and immediately start a new conversion cycle.

In the Idle state, the [Environmental Monitor](#) will transition to the Run state and start a Conversion Cycle when all the following conditions are true:

- The interval specified in the [Temperature Conversion Rate Configuration Register](#) completes
- Either the [PWRGD_IN](#) signal or the [LPM](#) bit are asserted

The SYS_SHDN# pin will not assert while [PWRGD_IN](#) is de-asserted, even if the [Environmental Monitor](#) is in the Run state. However, once SYS_SHDN# asserted, it will remain active low until SYS_SHDN_RST1# or SYS_SHDN_RST2 asserts.

37.9.5 VOLTAGE MONITORS

The [Environmental Monitor](#) contains inputs for measuring the VTR voltage as well as voltages VTT, VSET and VIN. The nominal value, range, and resolution of the input voltage channels are shown in [Table 37-12, "Voltage Input Characteristics"](#).

TABLE 37-12: VOLTAGE INPUT CHARACTERISTICS

Voltage Input	Nominal Input Voltage	Maximum Input Voltage	Resolution
VSET	600mV	800mV	3.125mV
VIN	600mV	800mV	3.125mV
VTR	3.3V	4.4V	17.18mV
VTT	1.8V	See Note 1	9.375mV

37.9.5.1 Input Attenuators

The VTT and VTR voltage inputs contain attenuators that are used to bias the nominal voltage to 3/4 of full scale on the ADC. The total impedance on these attenuators is typically 300k Ohm and each contains a low pass filter with a cutoff frequency of approximately 140kHz.

MEC1725

The VSET and VIN inputs do not have an attenuator. Any voltage above the Maximum voltage will result in a full scale reading.

37.9.6 TEMPERATURE MONITORS

The [Environmental Monitor](#) can monitor the temperature of up to four (4) externally connected diodes as well as the internal or ambient temperature. Each channel is configured with the following features enabled or disabled based on user settings and system requirements.

37.9.6.1 Resistance Error Correction

The [Environmental Monitor](#) includes active Resistance Error Correction to remove the effect of up to 100 ohms of series resistance. Without this automatic feature, voltage developed across the parasitic resistance in the remote diode path causes the temperature to read higher than the true temperature is. The error induced by parasitic resistance is approximately $+0.7^{\circ}\text{C}$ per ohm. Sources of parasitic resistance include bulk resistance in the remote temperature transistor junctions, series resistance in the CPU, and resistance in the printed circuit board traces and package leads. Resistance error correction in the [Environmental Monitor](#) eliminates the need to characterize and compensate for parasitic resistance in the remote diode path.

37.9.6.2 Beta Compensation

The forward current gain, or beta, of a transistor is not constant as emitter currents change. As well, it is not constant over changes in temperature. The variation in beta causes an error in temperature reading that is proportional to absolute temperature. This correction is done by implementing the BJT or transistor model for temperature measurement.

For discrete transistors configured with the collector and base shorted together, the beta is generally sufficiently high such that the percent change in beta variation is very small. For example, a 10% variation in beta for two forced emitter currents with a transistor whose ideal beta is 50 would contribute approximately 0.25°C error at 100°C . However for substrate transistors where the base-emitter junction is used for temperature measurement and the collector is tied to the substrate, the proportional beta variation will cause large error. For example, a 10% variation in beta for two forced emitter currents with a transistor whose ideal beta is 0.5 would contribute approximately 8.25°C error at 100°C .

The Beta Compensation circuitry in the [Environmental Monitor](#) corrects for this beta variation to eliminate any error which would normally be induced. It automatically detects the appropriate beta setting to use.

37.9.7 DIODE CONNECTIONS

The external diode channels support any diode connection shown below. The External Diode 2 - 4 channel settings can be modified at any time; however, the External Diode 1 settings are fixed at power up based on the pull-up resistor setting of VSET pin and can be changed based on the setting of the OVRD bit in the [Special Function Register on page 541](#).

FIGURE 37-4: DIODE CONNECTIONS

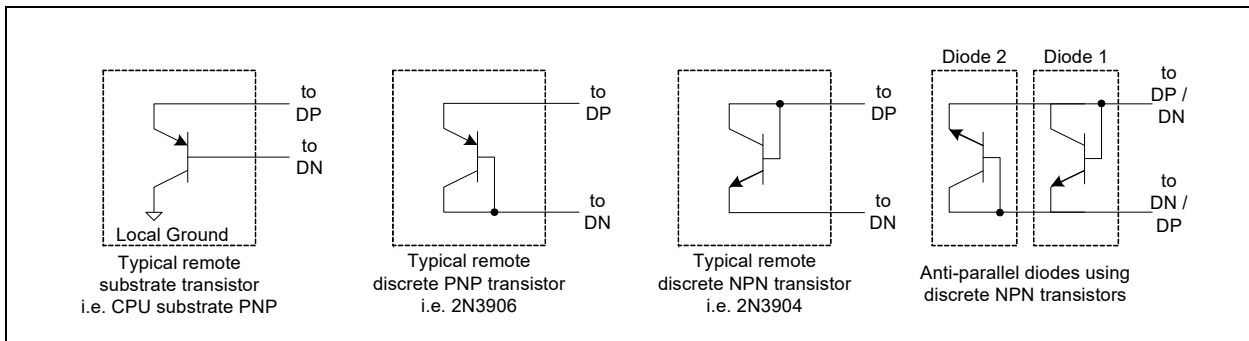

37.9.7.1 Anti-Parallel Diode Capability

The [Environmental Monitor](#) has another unique technology available to allow two thermal diodes to share a single DP/DN temperature sensing pair. The “Anti-Parallel” circuit drives measurement currents alternately in opposite directions to measure first one, then the other diode. Because the diodes are reverse biased relative to each other, their temperatures can be measured independently. This arrangement can provide a very efficient pin usage. [Figure 6.5, “Anti-Parallel Diode Configuration”](#) illustrates the Anti-Parallel diode configuration.

See reference [1] for more information on using the Anti-Parallel Diode technology.

FIGURE 37-5: ANTI-PARALLEL DIODE CONFIGURATION

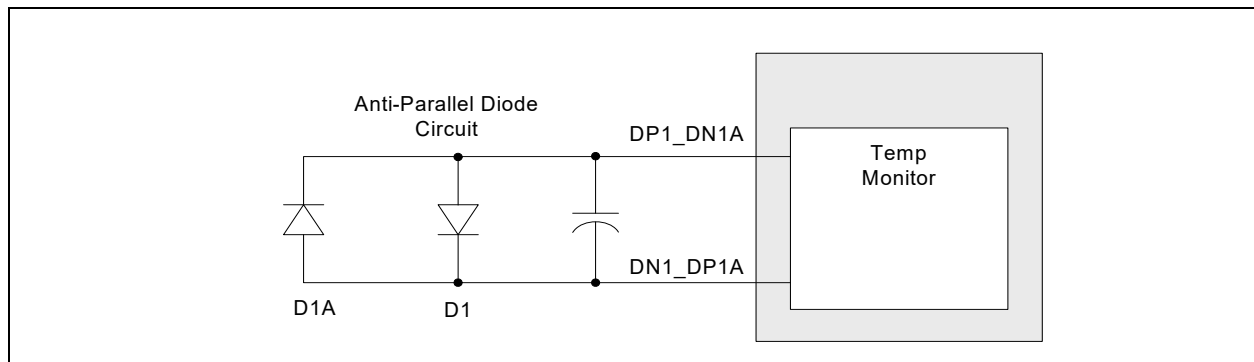

Note: This technique must not be used for CPU and GPU thermal diodes that require the BJT or transistor models

It is recommended that the PCB layout includes capacitor footprints near the [Environmental Monitor](#) interface and near each thermal diode. The capacitors near thermal diodes are normally not placed.

37.9.7.2 Diode Faults

The [Environmental Monitor](#) actively detects an open and short condition on each measurement channel. When a diode fault is detected, the temperature data MSByte is forced to a value of 80h and the FAULT bit is set in the Status Register.

Because of the nature of the thermal monitoring hardware, it is not possible to directly detect diode faults on anti-parallel diodes. Parallel diodes, even if an anti-parallel diode is connected to the same diode pins, will report an out-of-range temperature of 80h, along with a diode fault bit, whenever there is either an open diode fault or a shorted diode fault. Anti-parallel diodes will not return a value of 80h, but instead will return readings of temperatures at the ends of the range. An open fault will return the largest reading, 7Fh, which corresponds to a temperature of 127°C. The Fault Status bit will not be set. A diode fault caused by a short will return the minimum reading, C0h, which corresponds to a temperature of -64°C. In this case, the Fault Status bit will be set, because the short affects the parallel diode as well.

Diode fault behavior for anti-parallel diodes is summarized in the following table:

Actual Data		Description
Temp Reading Register	Fault Int Status	
7Fh	0	Open Diode Fault (7Fh = 127 °C)
C0h	1	Shorted Diode Fault (C0h = -64 °C)

37.9.8 ADC/THERMISTOR SUPPORT ON EXTERNAL DIODE LINES

The External Diode 1 channel normally monitors a 2N3904 diode in the CPU well. The measured temperature is compared against ThermTrip Temperature threshold determined by the VSET voltage and SYS_SHDN# is asserted if it exceeds the set point.

To allow a longer trace run to the CPU well, the [Environmental Monitor](#) can also use a thermistor as the critical shutdown thermal sensor. The resistor/thermistor divider voltage is driven out on DP1 when a measurement is made, and the voltage measurement is made on DN1. This reading can be capacitively filtered with a 0.1uF cap and is inherently averaged by the delta-sigma ADC so the results are very noise immune.

Additionally, the data measured on the DN1 / THERM pin will be automatically inverted (subtracted from FFh) prior to being loaded into the data registers.

When changing between measuring a diode and a thermistor, the limit settings may cause invalid interrupts. It is recommended that the channels be disabled until the limits are properly configured.

MEC1725

When configured to measure a thermistor on the External Diode 1 channel, it is the user's responsibility to set the VSET voltage to an appropriate level to emulate the desired threshold temperature. The [Environmental Monitor](#) will perform no calculations to translate the VSET voltage to an equivalent thermistor voltage. Additionally, high and low limits comparisons are not changed so the user should set the limits to appropriate values.

Note: Thermistor mode does not convert the ADC codes to temperature readings. Thermistor linearization, or a look up table, needs to be done in the EC if actual temperature values are required.

The External Diode 2-4 channels can also be configured to use a thermistor instead of a diode. See [Section 37.10.5, "Thermistor Configuration Register"](#).

37.9.9 VOLTAGE PROGRAMMABLE FAIL-SAFE TEMPERATURE MONITOR

The Voltage Programmable Fail-Safe Temperature monitor provides thermal fail-safe detection without software intervention or programming. The voltage determined on the VSET input determines the logic threshold for the temperature measured by External Diode 1.

The Voltage Programmable Fail-Safe Temperature Monitor operates off of the VTR power supply.

The chip samples the VSET voltage on the first monitoring conversion cycle following a [RESET_SYS](#). Monitoring is active as shown in [Table 37-10, "Monitoring"](#). A threshold temperature is calculated based on the VSET voltage and stored it in ThermTrip Temperature Register Diode 1 register.

37.9.9.1 VSET Pin

The [Environmental Monitor's](#) VSET pin is an input to ThermTrip block which sets ThermTrip shutdown temperature. The system designer creates a voltage level at this input through a simple resistor connected to GND as shown in [Figure 37-6, "VSET Circuit"](#). The value of this resistor (RSET in [Figure 37-6](#)) is used to create an input voltage on the VSET pin which is translated into a temperature ranging from 60°C to 123°C as enumerated in [Table 37-13, "VSET Resistor Setting"](#).

VSET is designed to operate using a 1% resistor. If a 5% resistor is used, the decoded temperature may have as much as 1°C error.

An open condition on the VSET pin will be decoded as a minimum temperature threshold level.

FIGURE 37-6: VSET CIRCUIT

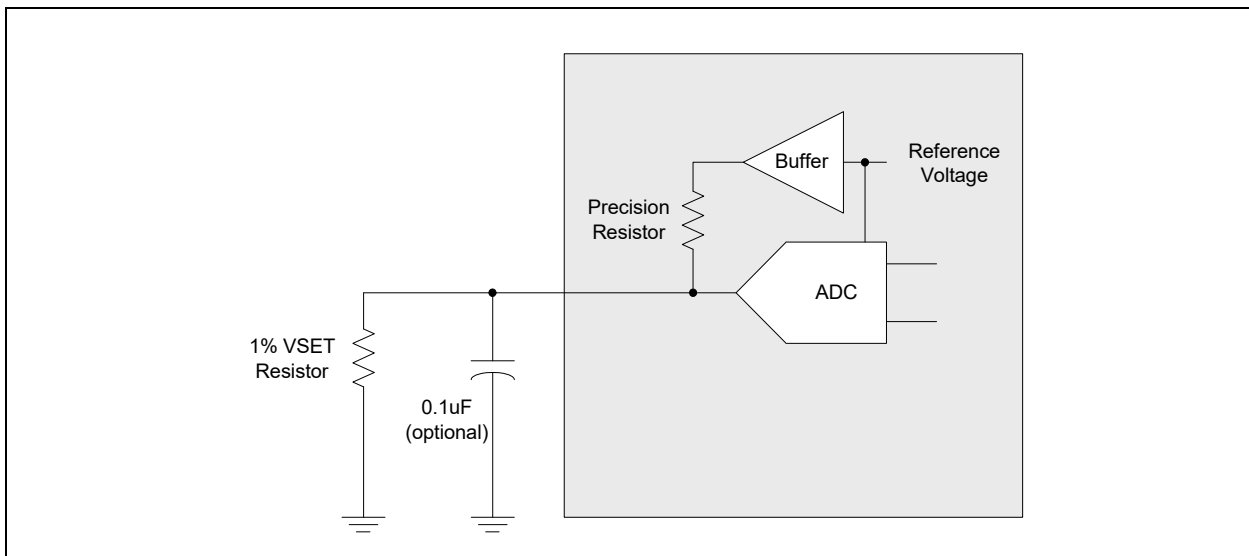

Note: The values in [Table 37-13](#) are subject to change after characterization of the part.

TABLE 37-13: VSET RESISTOR SETTING

TTRIP (°C)	RSET	TTRIP (°C)	RSET
60	0.0	92	1240.0
61	28.7	93	1330.0
62	48.7	94	1400.0
63	69.8	95	1500.0
64	90.9	96	1580.0
65	113.0	97	1690.0
66	137.0	98	1820.0
67	158.0	99	1960.0
68	182.0	100	2050.0
69	210.0	101	2210.0
70	237.0	102	2370.0
71	261.0	103	2550.0
72	294.0	104	2740.0
73	324.0	105	2940.0
74	348.0	106	3160.0
75	383.0	107	3480.0
76	412.0	108	3740.0
77	453.0	109	4120.0
78	487.0	110	4530.0
79	523.0	111	4990.0
80	562.0	112	5490.0
81	604.0	113	6190.0
82	649.0	114	6980.0
83	698.0	115	7870.0
84	750.0	116	9090.0
85	787.0	117	10700.0
86	845.0	118	13000.0
87	909.0	119	16200.0
88	953.0	120	21500.0
89	1020.0	121	30900.0
90	1100.0	122	49900.0

MEC1725

TABLE 37-13: VSET RESISTOR SETTING (CONTINUED)

TTRIP (°C)	RSET	TTRIP (°C)	RSET
91	1150.0	60	Open

37.9.9.2 Internal HW_FAILSAFE# Signal

The internal HW_FAILSAFE# signal is asserted if there is an over-temperature condition on at least one of the External Diodes. The HW_FAILSAFE# signal is valid when monitoring is active as shown in [Table 37-10, "Monitoring"](#).

HW_FAILSAFE# is an input to the [ThermTrip Logic](#), which may result in the assertion of the [SYS_SHDN#](#) output. The HW_FAILSAFE# state is reflected in the HWFS bit in the [Failsafe Status Register](#).

An over temperature event occurs when the temperature of an External Diode exceeds the programmed limit in the [ThermTrip Temperature Registers](#). The operation of the HW_FAILSAFE# signal is described below for External Diode 1 using the threshold computed from VSET.

The status bits in the [Shutdown Status Register](#) indicate which diode had an over-temperature event that caused the HW_FAILSAFE# signal to go active. Note that only diodes that are enabled using bits in the [Shutdown Configuration Register](#) will cause the HW_FAILSAFE# signal to go active.

The HW_FAILSAFE# signal asserts when the External Diode 1 temperature exceeds the temperature threshold (TP) established by the VSET input pin after the first conversion cycle (as shown in [Figure 37-7, "Example #1 of HW_FAILSAFE# Operation"](#)).

HW_FAILSAFE# is also asserted when the External Diode 1 temperature exceeds TP minus 10°C during the first valid conversion cycle (as shown in [Figure 37-8, "Example #2 of HW_FAILSAFE# Operation"](#)).

In both cases, the over-temperature condition is considered to be cleared when the diode temperature drops below TP, at which time the HWFS bit and the [SYS_SHDN#](#) output may be deasserted.

FIGURE 37-7: EXAMPLE #1 OF HW_FAILSAFE# OPERATION

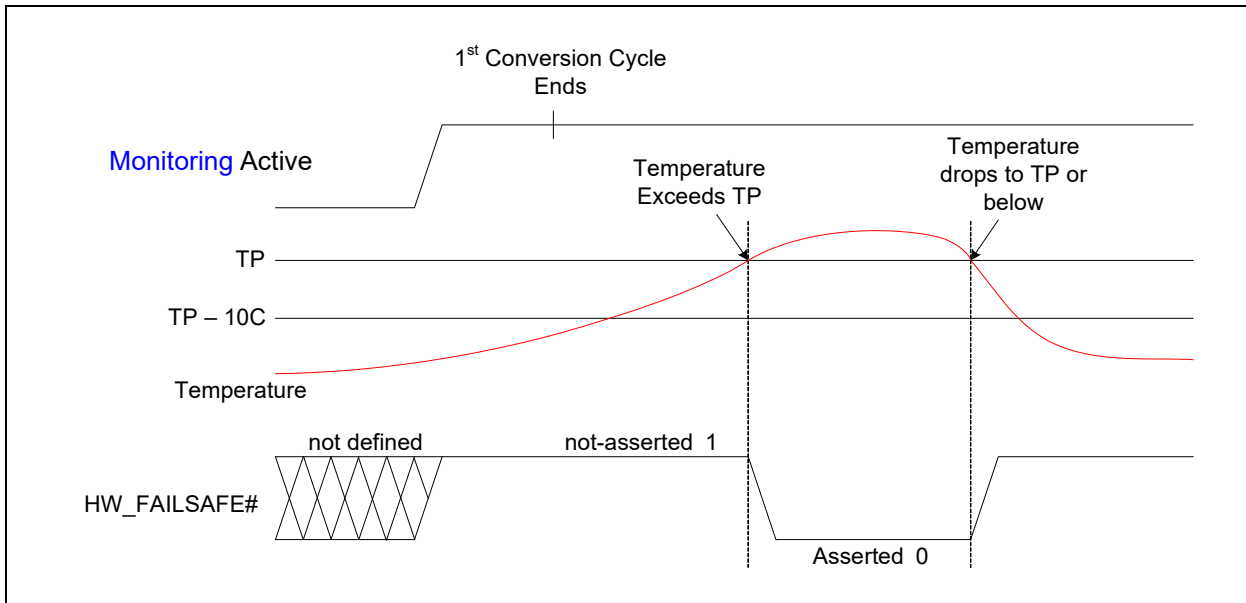
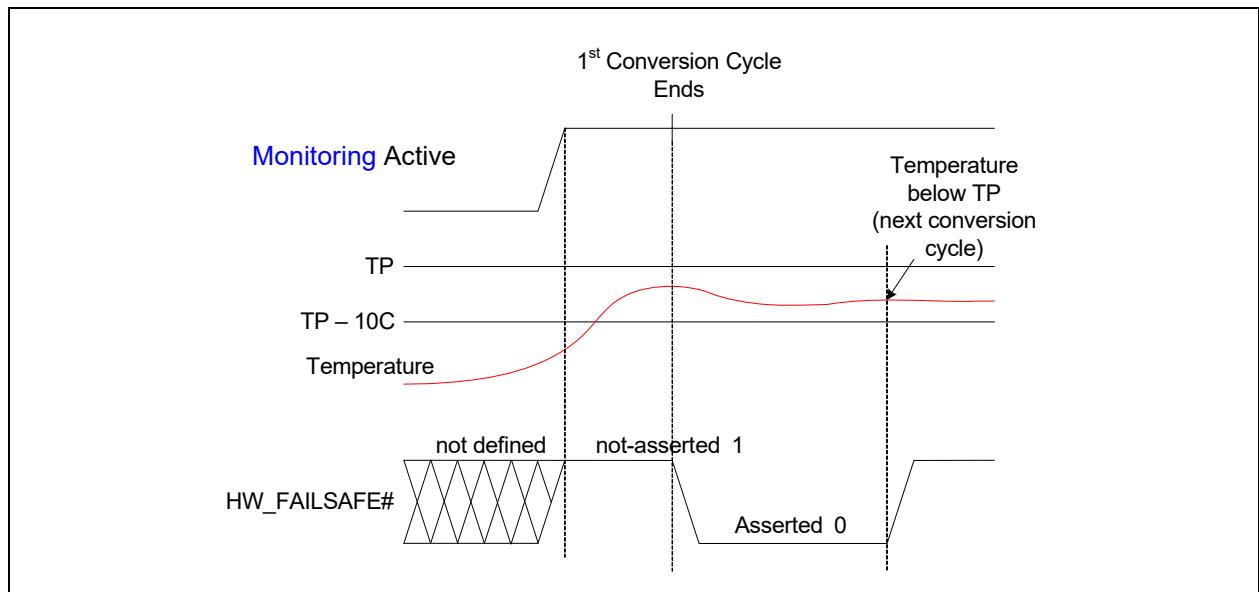

FIGURE 37-8: EXAMPLE #2 OF HW_FAILSAFE# OPERATION



37.9.10 THERMTRIP LOGIC

The [Environmental Monitor](#) ThermTrip logic uses the HW_FAILSAFE# signal in addition to the SYS_SHDN#, SYS_SHDN_RST1# and SYS_SHDN_RST2 pins.

The SYS_SHDN#, SYS_SHDN_RST1# and SYS_SHDN_RST2 signals are powered by the VBAT supply. In addition, this supply signal powers all of ThermTrip Logic integration as well an internal status register that indicates which of the inputs caused the outputs to be asserted.

The signal interaction is shown in [Table 37-14, "ThermTrip Logic Functionality"](#).

TABLE 37-14: THERMTRIP LOGIC FUNCTIONALITY

Control Signals				Output	Description
HW_FAILSAFE#	PWRGD_IN	SHDN_RST1#	SHDN_RST2	SYS_SHDN#	
X	0	1	0	no change	Power is not supplied. HW_FAILSAFE# is ignored and output remains unchanged
1	1	1	0	no change	Power is supplied, but the Input is not asserted. The output does not change state
0	1	1	0	0	Power is supplied. The input asserting to '0' causes the output to be asserted.
X	X	1->0	X	1	The SYS_SHDN_RST1# and SYS_SHDN_RST2 pins acts as a reset for the logic block - both pins generate a short duration pulse when asserted so that holding either pin in the asserted state ('0' for SYS_SHDN_RST1# or '1' for SYS_SHDN_RST2) will not permanently disable the ThermTrip logic block.
X	X	X	0->1		

37.9.10.1 SYS_SHDN_RST1# Pin

The SYS_SHDN_RST1# pin is used in the ThermTrip logic integration as a reset input for the circuitry. In order to prevent a device from holding the SYS_SHDN_RST1# low and effectively holding the ThermTrip logic inactive, the SYS_SHDN_RST1# pin has some special logic added to it that generates a short duration (~1 clock pulse) reset pulse that is triggered on the falling edge of the SYS_SHDN_RST1# pin.

37.9.10.2 SYS_SHDN_RST2 Pin

The SYS_SHDN_RST2 pin, like the SYS_SHDN_RST1# pin, is used by the ThermTrip logic integration as a reset input for the circuitry. In order to prevent a device from holding the SYS_SHDN_RST2 pin high and effectively holding the ThermTrip logic inactive, the SYS_SHDN_RST2 pin has some special logic added to it that generates a short duration (~1 clock pulse) reset pulse that is triggered on the rising edge of the SYS_SHDN_RST2 pin.

37.9.10.3 Use of the SYS_SHDN# Pin

The [Environmental Monitor](#) provides a critical threshold facility that can be used as a fail-safe temperature monitor. If a thermal event occurs, the fail-safe monitor asserts the SYS_SHDN# signal which can de-assert the VCI_OUT pin that is associated with the VBAT-Powered Control Interface.

In addition, the [Environmental Monitor](#) can assert a pin, SYS_SHDN#, when there is a thermal event. The SYS_SHDN# pin function must be enabled using its associated GPIO control register. The SYS_SHDN# pin can be used in a system in two ways:

1. **Hardware Failsafe.** In this mode, the SYS_SHDN# signal turns off VTR power.
2. **System Shutdown Monitor.** In this mode, the SYS_SHDN# pin has no effect on VTR power, but can be used in the system as a status signal indicating an over-temperature condition.

37.9.10.3.1 Hardware Failsafe

When used in this manner, the SYS_SHDN# pin is connected directly to the power regulator that provides the VTR power rail, which powers the EC. The response to a critical temperature threshold violation would proceed as follows:

1. The [Environmental Monitor](#) measures the temperature on Diode 1 and detects a temperature that exceeds the level programmed by the VSET resistor.
2. The SYS_SHDN# pin is asserted, which also de-asserts VCI_OUT.
3. The regulator that provides the VTR power rail is shut down.
4. The EC is shut down, except for VBAT-powered circuitry.
5. The VTR power rails remains off until a transition on one of the VCI_IN# input signals causes VCI_OUT to be asserted. This will cause the VTR regulator to turn on, providing VTR power.
6. The EC resets and restarts.

37.9.10.3.2 System Shutdown Monitor

The SYS_SHDN# pin may be used by the system to note an over-temperature condition. Because the logic that drives SYS_SHDN# responds to changes in the critical temperature comparison logic, rather than the current state of the comparator, the system may be required to re-arm the monitor logic. The response to a critical temperature threshold violation would proceed as follows:

1. A critical temperature violation condition causes SYS_SHDN# to be asserted. This also can cause an interrupt to the firmware.
2. After noting the cause of the event, firmware should set the [SYS_SHDN_RST](#) bit in the [System Shutdown Reset Register](#) to 1.
3. Setting it to 1 de-asserts the SYS_SHDN# pin.
4. The [SYS_SHDN_RST](#) bit is not self-clearing and must be reset to '0' by firmware. No delay is required between successive writes to the bit.
5. Firmware should set the CFS bit in the Special Function Register to 1. This clears the Failsafe Status Register, which records the internal status of the failsafe logic, and the Shutdown Status Register, which records which sensor was responsible for causing the assertion of the pin.
6. Once de-asserted, the SYS_SHDN# pin will only be asserted when one of the following three conditions occur:
 - a) The system temperature drops below and subsequently rises above the ThermTrip temperature limit.
 - b) The ThermTrip temperature limit is set to a value over the current temperature on any sensor that caused the over-temperature event, and is subsequently set to a temperature below the current temperature of any enabled

sensor. This forces the internal over-temperature status to assert and then de-assert, causing the edge that triggers SYS_SHDN#.

- c) The bits in the Shutdown Configuration Register that enable diodes to trigger the assertion of SYS_SHDN# should be set to 0 (to disable all diodes) and then to 1 for all diodes that should trigger a shutdown event. Firmware must wait at least 62µS (that is, two periods of the 32.768KHz clock) between writing the [System Shutdown Reset Register](#) and writing the Shutdown Configuration Register.

37.9.11 ALERTS AND LIMITS

[Figure 37-9, "Interrupt Flow"](#) shows the interactions of the interrupts for temperature channels and voltage channels.

The [Environmental Monitor](#) contains both high and low limits for all temperature channels and both high and low limits for VTT, VIN and VTR. If the corresponding channel exceeds these limits (by either being too high or too low), the interrupt signal will be asserted (if enabled). If an external diode detects a diode fault, the interrupt signal will be asserted low (if enabled).

All of these interrupts can be masked from asserting the interrupt signal individually. If any bit of either Status register is set, the interrupt signal will be asserted provided that the corresponding interrupt enable bit is set accordingly.

The Status register will be updated due to an active event, regardless of the setting of the individual enable bits. Once a status bit has been set, it will remain set until the Status register bit is written to 1 (and the error condition has been removed).

If the interrupt signal is asserted, it will be cleared immediately if either the status or enable bit is cleared.

The Voltage Programmable Fail-Safe Temperature Monitor can be masked from asserting the interrupt signal; however, it will always affect ThermTrip logic block normally.

See [Section 37.7, "Interrupts"](#).

FIGURE 37-9: INTERRUPT FLOW

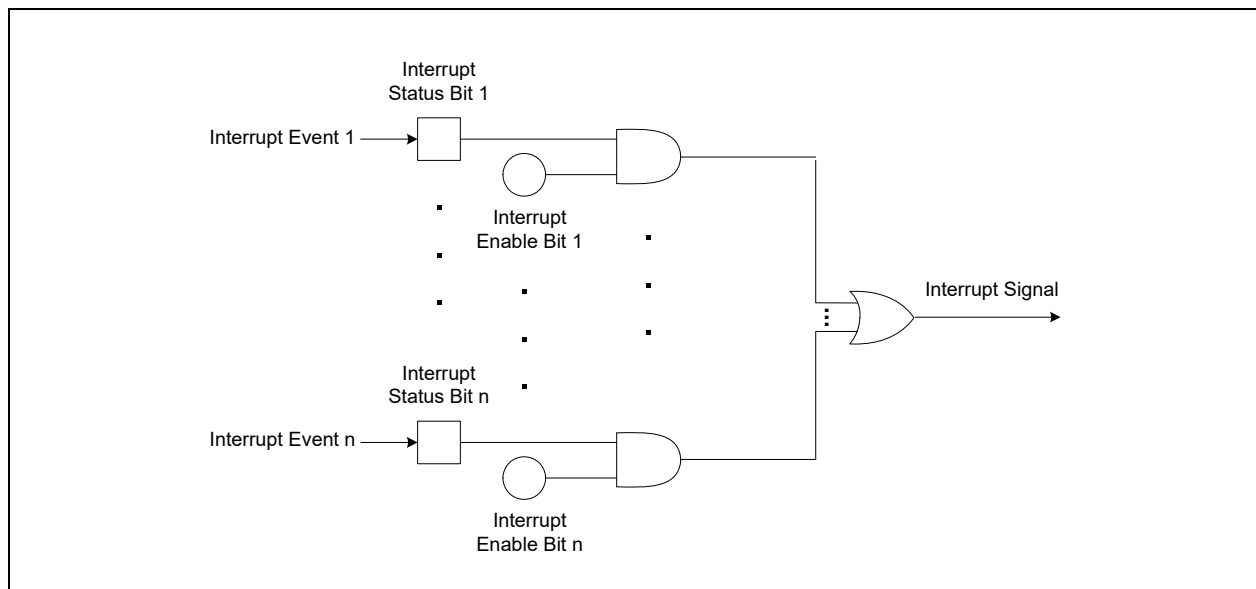

37.10 Environmental Monitor Register Bank

Registers for this block are shown in the following summary table. Addresses for each register are determined by adding the offset to the Base Address for each instance of the [Environmental Monitor](#) Block in the Block Overview and Base Address Table in [Section 3.0, "Device Inventory"](#).

Note: Test locations should not be modified from their default value. Changing an Test register or bit may cause unwanted results.

TABLE 37-15: ENVIRONMENTAL MONITOR REGISTER SUMMARY

Offset	R/W	Name	Description	RESET_SYS Default Value	Lock (Note 1)
00h	R	External Diode 1 Temperature Low Byte	Stores fractional data for External Diode 1	00h	No
01h	R	External Diode 1 Temperature High Byte	Stores the integer data of External Diode 1 or the Thermistor Input if enabled	00h	No
02h	R	Internal Temperature Low Byte	Stores fractional data for the Internal Diode (used to measure T_{DIE})	00h	No
03h	R	Internal Temperature High Byte	Stores integer data for the Internal Diode (used to measure T_{DIE})	00h	No
04h	R	External Diode 2 Temperature Low Byte	Stores the fractional data for External Diode 2	00h	No
05h	R	External Diode 2 Temperature High Byte	Stores the Integer data for External Diode 2 or the Thermistor Input if enabled	00h	No
06h	R	External Diode 3 Temperature Low Byte	Stores the fractional data for External Diode 3	00h	No
07h	R	External Diode 3 Temperature High Byte	Stores the integer data for External Diode 3 or the Thermistor Input if enabled	00h	No
08h	R	External Diode 4 Temperature Low Byte	Stores the fractional data for External Diode 4	00h	No
09h	R	External Diode 4 Temperature High Byte	Stores the integer data for External Diode 4 or the Thermistor Input if enabled	00h	No
0Ah-0Dh	R	Reserved	Reserved	00h	No
0Eh	R	VIN Voltage	Stores the voltage Measured on VIN channel	FFh	No
0Fh-11h	R	Reserved	Reserved	00h	No
12h	R	External Diode 1A Temperature Low Byte	Stores the fractional data for External Diode 1A	00h	No
13h	R	External Diode 1A Temperature High Byte	Stores the integer data for External Diode 1A	00h	No
14h	R	External Diode 2A Temperature Low Byte	Stores the fractional data for External Diode 2A	00h	No
15h	R	External Diode 2A Temperature High Byte	Stores the integer data for External Diode 2A	00h	No
16h	R	External Diode 3A Temperature Low Byte	Stores the fractional data for External Diode 3A	00h	No
17h	R	External Diode 3A Temperature High Byte	Stores the integer data for External Diode 3A	00h	No
18h	R	External Diode 4A Temperature Low Byte	Stores the fractional data for External Diode 4A	00h	No

TABLE 37-15: ENVIRONMENTAL MONITOR REGISTER SUMMARY (CONTINUED)

Offset	R/W	Name	Description	RESET_SYS Default Value	Lock (Note 1)
19h	R	External Diode 4A Temperature High Byte	Stores the integer data for External Diode 4A	00h	No
20h	R	Reserved	Reserved	00h	No
21h	R	Test	Test	N/A	N/A
22h	R	VTR Voltage Reading	Stores the VTR Voltage Monitor data	FFh	No
23h	R	VTT Voltage Reading	Stores the VTT Voltage Monitor data	FFh	No
24h-2Ah	R	Reserved	Reserved	00h	No
Configuration and Control					
2Bh	R/W	Temperature Configuration 1	Controls whether temperature sensing is performed for external diodes	00h	SWL
2Ch	R/W	Temperature Configuration 2	Controls whether temperature sensing is performed for internal diode	00h	SWL
2Dh	R/W	Voltage Configuration	Controls whether voltage sensing is performed for voltages	00h	SWL
2Eh	R/W	Thermistor Configuration	Diode or Thermistor Configuration	00h	SWL
2Fh	R/W	Temperature Conversion Configuration	Controls the Temperature Conversion for the temperature channels	00h	SWL
30h	R/W	Averaging Enable	Controls software averaging	00h	SWL
31h-37h	R	Reserved	Reserved	00h	No
Beta Configuration					
38h	R/W	External Diode 1 Beta Configuration	Configures the beta compensation settings for External Diode 1	00h	SWL
39h	R/W	External Diode 2 Beta Configuration	Configures the beta compensation settings for External Diode 2	1Fh	SWL
3Ah	R	Reserved	Reserved	00h	No
3Bh	R	Reserved	Reserved	00h	No
3Ch	R	Reserved	Reserved	00h	No
3Dh	R	Reserved	Reserved	00h	No
3Eh	R	Reserved	Reserved	00h	No
3Fh	R	Reserved	Reserved	00h	No
Control					
40h	R/W	Lock Start	Enables the software lock functionality and gives status of the monitoring functionality.	01h	SWL
Interrupt Status					
41h	RWC	Fault Interrupt Status Register	Stores the status of the External Diode Faults	00h	No
42h	RWC	Temp Interrupt Status Register	Stores the status bits for the External Diode channels	00h	No
43h	R	ThermTrip Pin State	Stores the pin state of the signals that affect the SYS_SHDN# signal	00h	No
44h	RWC	Int Temp Interrupt Status Register	Stores the status bits for the Internal Diode	00h	No
45h	RWC	Volt Interrupt Status Register	Stores the status bits for voltage inputs	00h	No
Limit Registers					
46h	R/W	Test	Test	N/A	N/A

MEC1725

TABLE 37-15: ENVIRONMENTAL MONITOR REGISTER SUMMARY (CONTINUED)

Offset	R/W	Name	Description	RESET_SYS Default Value	Lock (Note 1)
47h	R/W	Test	Test	N/A	N/A
48h	R/W	VTR Low Limit	Low Limit for VTR Voltage Monitor	00h (0V)	SWL
49h	R/W	VTR High Limit	High Limit for VTR Voltage Monitor	FFh (4.4V)	SWL
4Ah	R/W	VTT Low Limit	Low Limit for VTT Voltage Monitor	00h (0V)	SWL
4Bh	R/W	VTT High Limit	High Limit for VTT Voltage Monitor	FFh (2.4V)	SWL
4Ch	R/W	VIN Low Limit	Low Limit for VIN Input Channel	00h (0V)	SWL
4Dh	R/W	VIN High Limit	High Limit for VIN Input Channel	FFh (800mV)	SWL
4Eh	R/W	External Diode 1 Temp Low Limit	Low limit for External Diode 1	81h (-127°C)	SWL
4Fh	R/W	External Diode 1 Temp High Limit	High limit for External Diode 1	7Fh (+127°C)	SWL
50h	R/W	Internal Temp Low Limit	Low limit for the Internal Diode	81h (-127°C)	SWL
51h	R/W	Internal Temp High Limit	High limit for the Internal Diode	7Fh (127°C)	SWL
52h	R/W	External Diode 2 Temp Low Limit	Low limit for External Diode 2	81h (-127°C)	SWL
53h	R/W	External Diode 2 Temp High Limit	High limit for External Diode 2	7Fh (127°C)	SWL
54h	R/W	External Diode 3 Temp Low Limit	Low limit for External Diode 3	81h (-127°C)	SWL
55h	R/W	External Diode 3 Temp High Limit	High limit for External Diode3	7Fh (127°C)	SWL
56h	R/W	External Diode 4 Temp Low Limit	Low limit for External Diode 4	81h (-127°C)	SWL
57h	R/W	External Diode 4 Temp High Limit	High limit for External Diode 4	7Fh (127°C)	SWL
58h	R/W	External Diode 1A Temp Low Limit	Low limit for External Diode 1A	81h (-127°C)	SWL
59h	R/W	External Diode 1A Temp High Limit	High limit for External Diode 1A	7Fh (127°C)	SWL
5Ah	R/W	External Diode 2A Temp Low Limit	Low limit for External Diode 2A	81h (-127°C)	SWL
5Bh	R/W	External Diode 2A Temp High Limit	High limit for External Diode 2A	7Fh (127°C)	SWL
5Ch	R/W	External Diode 3A Temp Low Limit	Low limit for External Diode 3A	81h (-127°C)	SWL
5Dh	R/W	External Diode 3A Temp High Limit	High limit for External Diode 3A	7Fh (127°C)	SWL
5Eh	R/W	External Diode 4A Temp Low Limit	Low limit for External Diode 4A	81h (-127°C)	SWL
5Fh	R/W	External Diode 4A Temp High Limit	High limit for External Diode 4A	7Fh (127°C)	SWL
60h-63h	R	Reserved	Reserved	00h	No
64h	R/W	External Diode 3 Beta Configuration	Configures the beta compensation settings for External Diode 3	1Fh	SWL
65h	R/W	External Diode 4 Beta Configuration	Configures the beta compensation settings for External Diode 4	1Fh	SWL
66h	R	Reserved	Reserved	00h	No

TABLE 37-15: ENVIRONMENTAL MONITOR REGISTER SUMMARY (CONTINUED)

Offset	R/W	Name	Description	RESET_SYS Default Value	Lock (Note 1)
67h	R	Internal Diode Beta Setting	Stores the beta settings used by the internal diode	00h	No
68h-6Bh	R	Reserved	Reserved	00h	No
6Ch	R/W	Conversion Seconds Rate	Conversion Seconds Rate register	00h	SWL
6Dh	R	Reserved	Reserved	00h	No
6Eh	R/W	Conversion Mode	Conversion Rate Mode register	00h	SWL
6Fh	R	Reserved	Reserved	00h	No
Misc. Registers					
70h	R/W	REC Enable Register	Enables REC for all external diode channels	FFh	SWL
71h	R	VSET Voltage Reading	Stores the VSET Voltage Monitor reading	FFh	No
72h	R	Reserved	Reserved	00h	No
73h-74h	R	Reserved	Reserved	00h	No
75h	R	Thermal Trip Temperature Diode 1	Stores the calculated ThermTrip temperature high limit derived from the voltage on VSET and compared against External Diode 1.	7Fh	No
76h	R	FailSafe Status	Stores the status bits that indicate which ThermTrip input condition caused the SYS_SHDN# pin to be asserted.	00h on RESET_VBAT	No
77h	R/W	FailSafe Config	Stores configuration bits that are retained over all power modes	00h on RESET_VBAT	SWL
78h	R	Shutdown Status	Stores the status bits that indicate which diode caused the SYS_SHDN# output to assert.	00h on RESET_VBAT	No
79h	R	Shutdown Config	Controls which diode will cause the SYS_SHDN# pin to assert when it exceeds its threshold. Configuration bits are retained over all power modes	01h on RESET_VBAT	SWL
7Ah	R/W	Fault Interrupt Status Enable	Controls whether the External Diode Fault events generate an interrupt if the associated status bit is set.	00h	SWL
7Bh	R/W	Temp Interrupt Status Enable	Controls whether the External Diode events generate an interrupt if the associated status bit is set.	00h	SWL
7Ch	R/W	Special Function Register	Controls the bit that resets the FailSafe Status register	00h	No
7Dh	R/W	Int Temp Interrupt Status Enable	Controls whether the Internal Diode event generate an interrupt if the associated status bit is set.	00h	SWL
7Eh	R/W	Volt Interrupt Status Enable	Controls whether the voltage events generate an interrupt if the associated status bit is set.	00h	SWL
7Fh	R	Reserved	Reserved	00h	No
80h	R/W	Thermal Trip Temperature Diode 2	ThermTrip temperature high limit compared against External Diode 2	7Fh	No
81h	R/W	Thermal Trip Temperature Diode 3	ThermTrip temperature high limit compared against External Diode 3	7Fh	No
82h	R/W	Thermal Trip Temperature Diode 4	ThermTrip temperature high limit compared against External Diode 4	7Fh	No
83h	R/W	Thermal Trip Temperature Diode 1A	ThermTrip temperature high limit compared against External Diode 1A	7Fh	No

MEC1725

TABLE 37-15: ENVIRONMENTAL MONITOR REGISTER SUMMARY (CONTINUED)

Offset	R/W	Name	Description	RESET_SYS Default Value	Lock (Note 1)
84h	R/W	Thermal Trip Temperature Diode 2A	ThermTrip temperature high limit compared against External Diode 2A	7Fh	No
85h	R/W	Thermal Trip Temperature Diode 3A	ThermTrip temperature high limit compared against External Diode 3A	7Fh	No
86h	R/W	Thermal Trip Temperature Diode 4A	ThermTrip temperature high limit compared against External Diode 4A	7Fh	No
87h	R/W	Reserved	Reserved	00h	No
88h	R/W	Adjust Ch1	Contain EMC IP Trim Adjust values for External Channel 1	00h	SWL
89h	R/W	Adjust Ch2	Contain Adjust values for External Channel 2	00h	SWL
8Ah	R/W	Adjust Ch3	Contain Adjust values for External Channel 3	00h	SWL
8Bh	R/W	Adjust Ch4	Contain Adjust values for External Channel 4	00h	SWL
8Ch	R/W	Adjust Ch1A	Contain Adjust values for External Channel 1A	00h	SWL
8Dh	R/W	Adjust Ch2A	Contain Adjust values for External Channel 2A	00h	SWL
8Eh	R/W	Adjust Ch3A	Contain Adjust values for External Channel 3A	00h	SWL
8Fh	R/W	Adjust Ch4A	Contain Adjust values for External Channel 4A	00h	SWL
90h-97h	R/W	Test	Test	N/A	N/A
98h-9Bh	R	Reserved	Reserved	00h	No
9Ch-C1h	R	Test	Test	N/A	N/A
C2h-FBh	R	Reserved	Reserved	00h	No
FCh	R	Unlock	Unlock	00h	No
FDh-FFh	R	Test	Test	N/A	N/A
100h- 3FFh	R	Reserved	Reserved	00h	No
400h	R/W	System Shutdown Reset	Used to de-assert the SYS_SHDN# signal	00h	No

Note: Any reads to undefined registers will return 00h. Writes to undefined registers will not have an effect.

Note 1: Software Lock (SWL) is controlled by the Lock bit in [Section 37.10.8, "Lock Start Register,"](#) on page 532. Registers designated as SWL are Read-Only when the Lock bit is set.

37.10.1 TEMPERATURE DATA REGISTERS

TABLE 37-16: TEMPERATURE DATA REGISTERS

ADDR	Register	B7	B6	B5	B4	B3	B2	B1	B0	Lock	Default
00h	External Diode 1 Low Byte	0.5	0.25	0.125	0.0625	RES	RES	RES	RES	No	00h
01h	External Diode 1 High Byte	Sign	64	32	16	8	4	2	1	No	00h
02h	Internal Temp Low Byte	0.5	RES	RES	RES	RES	RES	RES	RES	No	00h
03h	Internal Temp High Byte	Sign	64	32	16	8	4	2	1	No	00h
04h	External Diode 2 Low Byte	0.5	0.25	0.125	0.0625	RES	RES	RES	RES	No	00h
05h	External Diode 2 High Byte	Sign	64	32	16	8	4	2	1	No	00h
06h	External Diode 3 Low Byte	0.5	0.25	0.125	0.0625	RES	RES	RES	RES	No	00h
07h	External Diode 3 High Byte	Sign	64	32	16	8	4	2	1	No	00h
08h	External Diode 4 Low Byte	0.5	0.25	0.125	0.0625	RES	RES	RES	RES	No	00h
09h	External Diode 4 High Byte	Sign	64	32	16	8	4	2	1	No	00h
12h	External Diode 1A Low Byte	0.5	0.25	0.125	0.0625	RES	RES	RES	RES	No	00h
13h	External Diode 1A High Byte	Sign	64	32	16	8	4	2	1	No	00h
14h	External Diode 2A Low Byte	0.5	0.25	0.125	0.0625	RES	RES	RES	RES	No	00h
15h	External Diode 2A High Byte	Sign	64	32	16	8	4	2	1	No	00h

MEC1725

TABLE 37-16: TEMPERATURE DATA REGISTERS (CONTINUED)

ADDR	Register	B7	B6	B5	B4	B3	B2	B1	B0	Lock	Default
16h	External Diode 3A Low Byte	0.5	0.25	0.125	0.0625	RES	RES	RES	RES	No	00h
17h	External Diode 3A High Byte	Sign	64	32	16	8	4	2	1	No	00h
18h	External Diode 4A Low Byte	0.5	0.25	0.125	0.0625	RES	RES	RES	RES	No	00h
19h	External Diode 4A High Byte	Sign	64	32	16	8	4	2	1	No	00h

As shown in [Table 37-16, "Temperature Data Registers"](#), each temperature monitor has two byte wide data registers. The 12 bit data temperature is stored aligned to the left resulting in the High Byte to contain temperature in 1°C steps and the Low Byte to contain fractions of a degree. The temperature format is shown below. The '-' entries represent bits are not part of the measured data and will be read as a logic '0'.

TABLE 37-17: TEMPERATURE DATA FORMAT

Temperature (°C)	2's Complement Format	
	Binary (12-bit)	Hex (12-bit)
Diode Fault	1000 0000 0000 ----b	80 00h
<= -63.9375	1100 0000 0001 ----b	C0 10h
-63	1100 0001 0000 ----b	C1 00h
-1	1111 1111 0000 ----b	FF 00h
0	0000 0000 0000 ----b	00 00h
0.0625	0000 0000 0001 ----b	00 10h
1	0000 0001 0000 ----b	01 00h
63	0011 1111 0000 ----b	3F 00h
64	0100 0000 0000 ----b	40 00h
65	0100 0001 0000 ----b	41 00h
126	0111 1110 0000 ----b	7E 00h
127	0111 1111 0000 ----b	7F 00h
>=127.9375	0111 1111 1111 ----b (Note 1)	7F F0h

Note 1: All temperatures above 127.9375°C will be reported as 127.9375°C. A Diode Fault will result in a stored reading of 80 00h.

Note: If Data Averaging for External Diodes 1-4 is enabled then the value stored is the averaged result not the actual reading. Data averaging is not available for the Internal Diode so the stored value is the actual reading.

When the External Diode channel is configured to operate in Thermistor mode, the External Diode High Byte is loaded with the measured voltage of the thermistor circuit instead of temperature data. The LSB will contain 00h.

37.10.2 VOLTAGE DATA REGISTERS

TABLE 37-18: VOLTAGE DATA REGISTERS

ADDR	Register	B7	B6	B5	B4	B3	B2	B1	B0	Lock	Default
0Eh	VIN	7	6	5	4	3	2	1	0	No	FFh
22h	VTR	7	6	5	4	3	2	1	0	No	FFh
23h	VTT	7	6	5	4	3	2	1	0	No	FFh
71h	VSET	7	6	5	4	3	2	1	0	No	FFh

The voltage data registers hold measured values of the voltage input channels. The resolution of the data is dependent upon which channel is being measured. The data is displayed in a binary form with 00h corresponding to 0V in and FFh corresponding to the an input that is equal to or greater than the maximum voltage.

The channels are configured so that the nominal voltage will equal 3/4 of full scale (high byte = C0h output). See [Table 37-19, "Voltage Data Format Example"](#).

TABLE 37-19: VOLTAGE DATA FORMAT EXAMPLE

Input Channel	Input Voltage	Data Reading	
		Binary	Hex
VSET/VIN (600mv nominal)	0V	0000 0000b	00h
	600mV	1100 0000b	C0h
	800mV	1111 1111b	FFh
VTR (3.3V nominal)	0V	0000 0000b	00h
	2.5V	1010 0010b	A2h
	3.3V	1100 0000b	C0h (3/4 full scale)
	4.4V	1111 1111b	FFh
VTT (1.8V nominal) Note 1	0V	0000 0000b	00h
	1.8V	1100 0000b	C0h (3/4 full scale)

Note 1: Voltage readings of the VTT voltage input are linear up to the nominal 1.8V reading, which is C0h. Input voltages above 1.8V saturate the reading, until a 3.3V input will return approximately CFh. Users can monitor nominal voltages up to about 1.6V and still obtain accurate readings when the input voltage is 10% over nominal. The reading can be used to determine that a nominal input voltage of 1.8V is over 1.8V, but not by how much.

MEC1725

37.10.3 TEMPERATURE CONFIGURATION REGISTERS

TABLE 37-20: TEMPERATURE CONFIGURATION REGISTER

ADDR	Register	B7	B6	B5	B4	B3	B2	B1	B0	Lock	Default
2Bh	Temperature Config 1	D4A	D3A	D2A	D1A	D4	D3	D2	D1	SWL	00h
2Ch	Temperature Config 2	RES	RES	RES	RES	RES	RES	RES	INT	SWL	00h

This register determines which temperatures readings are performed every conversion cycle.

37.10.3.1 Temperature Configuration Register 1 (2Bh)

Note: Bits[7:4] are used to enable/disable anti-parallel diode technology. When disabled, the DPX_DNXA and DNX_DPXA pins will be used only for the External Diode X channel. Any diode type (CPU, GPU, or diode connected transistor) can be connected to these pins. When the anti-parallel diode technology is enabled, the DPX_DNXA and DNX_DPXA pins will be used for both the External Diode X and the External Diode XA channels. The two diodes are connected in an anti-parallel fashion and only diode-connected transistors are supported for each diode.

Bit 7 - D4A - Controls whether temperatures readings are performed for Diode 4A. This bit enables anti-parallel diode technology on the DP4_DN4A and DN4_DP4A pins.

- '0' - Temperature readings disabled.
- '1' - Temperature readings enabled. This setting is ignored if Diode 4 is configured as a Thermistor.

Bit 6 - D3A - Controls whether temperatures readings are performed for Diode 3A. This bit enables anti-parallel diode technology on the DP3_DN3A and DN3_DP3A pins.

- '0' - Temperature readings disabled.
- '1' - Temperature readings enabled. This setting is ignored if Diode 3 is configured as a Thermistor.

Bit 5 - D2A - Controls whether temperatures readings are performed for Diode 2A. This bit enables anti-parallel diode technology on the DP2_DN2A and DN2_DP2A pins.

- '0' - Temperature readings disabled.
- '1' - Temperature readings enabled. This setting is ignored if Diode 2 is configured as a Thermistor.

Bit 4 - D1A - Controls whether temperatures readings are performed for Diode 1A. This bit enables anti-parallel diode technology on the DP1_DN1A and DN1_DP1A pins.

- '0' - Temperature readings disabled.
- '1' - Temperature readings enabled. This setting is ignored if Diode 1 is configured as a Thermistor.

Bit 3 - D4 - Controls whether temperatures readings are performed for Diode 4

- '0' - Temperature readings disabled.
- '1' - Temperature readings enabled.

Bit 2 - D3 - Controls whether temperatures readings are performed for Diode 3.

- '0' - Temperature readings disabled.
- '1' - Temperature readings enabled.

Bit 1 - D2 - Controls whether temperatures readings are performed for Diode 2

- '0' - Temperature readings disabled.
- '1' - Temperature readings enabled.

Bit 0 - D1 - Controls whether temperatures readings are performed for Diode 1. This bit is read-only.

- '1' - Temperature readings enabled.

37.10.3.2 Temperature Configuration Register 2 (2Ch)

Bit [7:1] Reserved

Bit 0 - INT - Controls whether temperatures readings are performed for the Internal Diode.

- '0' - Temperature readings disabled.
- '1' - Temperature readings enabled.

37.10.4 VOLTAGE CONFIGURATION REGISTER

TABLE 37-21: VOLTAGE CONFIGURATION REGISTER

ADDR	Register	B7	B6	B5	B4	B3	B2	B1	B0	Lock	Default
2Dh	Voltage Config	RES	RES	VSET	RES	VTT	VTR	VIN	Test	SWL	00h

This register determines which voltage readings are performed every conversion cycle.

Bits[7:6] Reserved

Bit 5 - VSET - Controls whether voltage readings are performed for VSET

- '0' - Voltage readings disabled.
- '1' - Voltage readings enabled.

Bit 4 Reserved

Bit 3 - VTT - Controls whether voltage readings are performed for VTT

- '0' - Voltage readings disabled.
- '1' - Voltage readings enabled.

Bit 2 - VTR - Controls whether voltage readings are performed for VTR.

- '0' - Voltage readings disabled.
- '1' - Voltage readings enabled.

Bit 1 - VIN - Controls whether voltage readings are performed for VIN

- '0' - Voltage readings disabled.
- '1' - Voltage readings enabled.
- Bit 0 - Test

37.10.5 THERMISTOR CONFIGURATION REGISTER

TABLE 37-22: THERMISTOR CONFIGURATION REGISTER

ADDR	Register	B7	B6	B5	B4	B3	B2	B1	B0	Lock	Default
2Eh	Thermistor Config	RES	RES	RES	RES	D4	D3	D2	D1	SWL	00h

The Thermistor Configuration Register controls whether temperature readings come from diodes or thermistors. The bits are described below.

Bit 3 - D4 - Enables thermistor readings on the DP4 / DN4 pins.

- '0' (default) - Diode readings.
- '1' - Thermistor readings

Bit 2 - D3 - Enables thermistor readings on the DP3 / DN3 pins.

- '0' (default) - Diode readings.
- '1' - Thermistor readings

MEC1725

Bit 1 - D2 - Enables thermistor readings on the DP2 / DN2 pins.

- '0' (default) - Diode readings.
- '1' - Thermistor readings

Bit 0 - D1 - Enables thermistor readings on the DP1 / DN1 pins.

- '0' - Diode readings.
- '1' - Thermistor readings

37.10.6 TEMPERATURE CONVERSION RATE CONFIGURATION REGISTER

TABLE 37-23: TEMPERATURE CONVERSION RATE CONFIGURATION REGISTER

ADDR	Register	B7	B6	B5	B4	B3	B2	B1	B0	Lock	Default
2Fh	Temperature Conversion Config	RES	RES	RES	RES	RES	RES	CONV[1:0]		SWL	00h

The Temperature Conversion Configuration Register controls the Temperature Conversion functionality of the [Environmental Monitor](#). The bits are described below.

Bit [7:2] Reserved

Bit [1:0] - CONV<1:0> - determine the temperature conversion rate that is used. The following table shows the temperature conversion rates available. Note that the [Environmental Monitor](#) is 'idle' during the delay time between round robin [Conversion Cycles](#), as described in [Table 37-24](#) (also see the "Power Management" section).

TABLE 37-24: TEMP CONVERSION RATE

CONV<1:0>		Conversion Rate
0	0	Continuous (no delay between round robin Conversion Cycles) (default)
0	1	1 second delay between round robin Conversion Cycles
1	0	0.5 second delay between round robin Conversion Cycles
1	1	Reserved

TABLE 37-25: AVERAGING ENABLE REGISTER

ADDR	Register	B7	B6	B5	B4	B3	B2	B1	B0	Lock	Default
30h	Averaging Enable	AVG_EN4A	AVG_EN3A	AVG_EN2A	AVG_EN1A	AVG_EN4	AVG_EN3	AVG_EN2	AVG_EN1	SWL	00h

The Averaging Enable Register controls the digital averaging per temperature channel. The bits are described below.

If enabled, the averaged result is loaded into the associated channel's reading register. If disabled, the current reading is loaded into the associated channel's reading register.

Averaging can be preformed for 2's complement Temperature Data as well as Voltage Readings.

Bit [7:0] - AVG_ENx - enables digital averaging.

- '0' (default) - digital averaging is not enabled on external diode x.
- '1' - digital averaging is enabled. External diode x temperature channels will be put into four stage running average. The temperature will continue to be updated after every conversion based on the average of the previous four measurement values

37.10.7 BETA CONFIGURATION REGISTERS

TABLE 37-26: BETA CONFIGURATION REGISTERS

ADDR	Register	B7	B6	B5	B4	B3	B2	B1	B0	Lock	Default
39h	External Diode 2 Beta Configuration	RES	RES	RES	AUTO2	BETA2[3:0]				SWL	1Fh
64h	External Diode 3 Beta Configuration	RES	RES	RES	AUTO3	BETA3[3:0]				SWL	1Fh
65h	External Diode 4 Beta Configuration	RES	RES	RES	AUTO4	BETA4[3:0]				SWL	1Fh

The Beta Configuration Registers hold a value that corresponds to a range of betas that the Beta Correction circuitry can compensate for. The Beta Configuration Registers activate the Beta Compensation circuitry if any value besides '1111' is written.

When the Beta Compensation circuitry is disabled, the diode channels will function with default current levels and will not automatically adjust for beta variation. They will still support the Ideality Configuration and the Resistance Error Correction Features.

Bit 4 - AUTOx - Enables the automatic beta circuitry. This circuitry automatically detects the optimal beta settings to be used for each external diode as it is measured.

- '0' - The automatic beta detection circuitry is disabled. The BETAx[3:0] bits will directly control the beta setting used. Writing to these bits will change the beta setting for the appropriate channel starting with the next conversion.
- '1' (default) - The automatic beta detection circuitry is enabled. The circuitry will automatically select the optimal beta settings for the connected diode. The BETAx[3:0] bits will be updated to reflect the current settings used. Writing to these bits will have no affect on the temperature measurement and the data will not be stored.

Bits 3 - 0 - BETAx[3:0] - These bits represent the current settings of the beta compensation circuitry. when the automatic beta detection circuitry is enabled, they are automatically updated based on the current settings. When the automatic beta detection circuitry is disabled, these bits should be set with a value corresponding to the lowest expected value of beta for the PNP transistor being used as a temperature sensing device. See [Table 37-27](#) for supported beta ranges.

APPLICATION NOTE: A diode connected transistor or an NPN transistor should use the '1111b' setting. For most applications, the automatic beta detection circuitry will determine the optimal settings to be used. Only disable the automatic beta detection circuitry if using a known transistor.

TABLE 37-27: BETA COMPENSATION LOOK UP

BETAX[2:0]				Minimum Beta
3	2	1	0	
0	0	0	0	0.050
0	0	0	1	0.066
0	0	1	0	0.087
0	0	1	1	0.114
0	1	0	0	0.150
0	1	0	1	0.197
0	1	1	0	0.260

MEC1725

TABLE 37-27: BETA COMPENSATION LOOK UP (CONTINUED)

BETAX[2:0]				Minimum Beta
3	2	1	0	
0	1	1	1	0.342
1	0	0	0	0.449
1	0	0	1	0.591
1	0	1	0	0.778
1	0	1	1	1.024
1	1	0	0	1.348
1	1	0	1	1.773
1	1	1	0	2.333
1	1	1	1	Disabled

37.10.8 LOCK START REGISTER

TABLE 37-28: LOCK START REGISTER

ADDR	Register	B7	B6	B5	B4	B3	B2	B1	B0	Lock	Default
40h	Lock/Start Register	RES	RES	RES	RES	RES	RES	LOCK (Note 1)	START	SWL	01h

Note 1: The UNLOCK bit located in the [Unlock Register on page 544](#) can be used to make this bit writable.

The Lock-Start register is included for legacy purposes and controls the Software Locking functionality.

Bit 1 - LOCK - this bit acts on all registers that are designated SWL. When this bit is set, the locked registers become read only and cannot be updated.

The LOCK bit is reset on RESET_SYS.

Bit 0 - START - The START bit is a READ ONLY Status bit that is set to '1' when [Monitoring](#) is enabled (see [Table 37-10, "Monitoring," on page 509](#)).

37.10.9 INTERRUPT STATUS REGISTERS

TABLE 37-29: INTERRUPT STATUS REGISTERS

ADDR	Register	B7	B6	B5	B4	B3	B2	B1	B0	Lock	Default
41h	Fault Error Interrupt Status Register	RES	RES	RES	RES	ERR4	ERR3	ERR2	ERR1	No	00h
42h	Temp Interrupt Status Register	TRD4A	TRD3A	TRD2A	TRD1A	TRD4	TRD3	TRD2	TRD1	No	00h

TABLE 37-29: INTERRUPT STATUS REGISTERS

ADDR	Register	B7	B6	B5	B4	B3	B2	B1	B0	Lock	Default
44h	Int Temp Interrupt Status Register	RES	RES	RES	RES	RES	RES	RES	TINT	No	00h
45h	Volt Interrupt Status Register	RES	RES	RES	CONV CNT DONE	VIN	VTR	Test	VTT	No	00h

The Interrupt Status Registers report the operating condition of the [Environmental Monitor](#). Each status bit can be individually enabled or disabled from causing an interrupt. If any of the bits are asserted then the Event Status Interrupt will be asserted if the associated enable bit is set to logic '1'.

Writing 1 to a status register bit will clear the status bit if the error condition is removed. If there are no set status bits, then the Event Status Interrupt will be released.

37.10.9.1 Fault Interrupt Status Register (41h)

Bit[7:4] - Reserved

Bit[3:0] - ERR[4:1] - this bit is asserted '1' if there is a diode fault error on External Diode [4:1]

Note: There is no diode fault indication for the APDs.

37.10.9.2 Temp Interrupt Status Register (42h)

Bit[7:4] - TRD[4:1]A - this bit is asserted '1' if the External Diode [4:1]A Temperature measurement exceeds the high limit or falls below the low limit

Bit[3:0] - TRD[4:1] - this bit is asserted '1' if the External Diode [4:1] Temperature measurement (or the THERM[4:1] channel measurement if enabled) exceeds the software defined high limit or falls below the software defined low limit. Exceeding the Temperature Programmable Voltage limit does not update the bit unless the temperature also exceeds the software high limit.

37.10.9.3 Int Temp/ Therm Interrupt Status Register (44h)

Bit[7:1] Reserved

Bit 0 - TINT - this bit is asserted '1' if the Internal temperature channel exceeds the high limit or falls below the low limit.

37.10.9.4 Voltage Interrupt Status Register (45h)

Bit [7:5] Reserved

Bit 4 - CONV CNT DONE - Conversion Counter Done Interrupt.

Interrupt Status Bit indicating that the Conversion Rate counter has expired and a Round Robin Conversion is requested. Will never fire in Continuous Mode (unless going from non-continuous to continuous, then it will fire once).

APPLICATION NOTE: This is a special wake-capable interrupt event used to restart the internal oscillator. This allows firmware to sleep the processor and enter low power modes in between conversions when the device is configured to periodically retrieve readings.

Bit 3 - VIN - This bit is asserted '1' if the VIN voltage exceeds the high limit or drops below the low limit.

Bit 2 - VTR- this bit is asserted '1' if the VTR voltage exceeds the high limit or drops below the low limit.

Bit 1- Test

Bit 0 - VTT - this bit is asserted '1' if the VTT input voltage exceeds the high limit or drops below the low limit.

MEC1725

37.10.10 THERMTRIP PIN STATE REGISTER

TABLE 37-30: THERMTRIP PIN STATE REGISTER

ADDR	Register	B7	B6	B5	B4	B3	B2	B1	B0	Lock	Default
43h	ThermTrip Pin State	DIODE_MD	RES	SYS_SHDN_RST2	SYS_SHDN_RST1#	Test	Test	Test	PWRGD_IN	No	00h

All bits in this register are read-only status or state bits.

Bit 7 - DIODE_MD - Indicates the select function for the External Diode 1 channel.

- '0' - The External Diode 1 channel is measuring a 2N3904 diode connected between the DP1 / VREF_T and DN1/ THERM pins.
- '1' - The External Diode 1 channel is measuring a thermistor input biased via the DP1 / VREF_T pin and measured on the DN1 / THERM pin.

Bit 6 Reserved

Bit 5 - SYS_SHDN_RST2 - reflects the state of the SYS_SHDN_RST2 signal.

Bit 4 - SYS_SHDN_RST1# - reflects the state of the SYS_SHDN_RST1# signal

Bit 3 - Test

Bit 2 - Test

Bit 1 - Test

Bit 0 - PWRGD_IN - Reflects the state of the [PWRGD_IN](#) signal.

37.10.11 VOLTAGE LIMIT REGISTERS

TABLE 37-31: VOLTAGE LIMIT REGISTERS

ADDR	Register	B7	B6	B5	B4	B3	B2	B1	B0	Lock	Default
48h	VTR Low Limit	7	6	5	4	3	2	1	0	SWL	00h
49h	VTR High Limit	7	6	5	4	3	2	1	0	SWL	FFh
4Ah	VTT Low Limit	7	6	5	4	3	2	1	0	SWL	00h
4Bh	VTT High Limit	7	6	5	4	3	2	1	0	SWL	FFh
4Ch	VIN Low Limit	7	6	5	4	3	2	1	0	SWL	00h
4Dh	VIN High Limit	7	6	5	4	3	2	1	0	SWL	FFh

The [Environmental Monitor](#) contains both high and low voltage limits for the VTR, VTT and VIN voltage inputs. These limits are compared to the appropriate measurement channel after every conversion cycle and whenever the limits are updated. If the high limit is exceeded, or the measured data is below the low limit, then the appropriate Status bit is set.

Note: The limit comparison is done with the voltage reading value, including the fractional portion.

37.10.12 TEMPERATURE LIMIT REGISTERS

TABLE 37-32: TEMPERATURE LIMIT REGISTERS

ADDR	Register	B7	B6	B5	B4	B3	B2	B1	B0	Lock	Default
4Eh	External Diode 1 Low Limit	Sign	64	32	16	8	4	2	1	SWL	81h (-127°C)
4Fh	External Diode 1 High Limit	Sign	64	32	16	8	4	2	1	SWL	7Fh (+127°C)
50h	Internal Temp Low Limit	Sign	64	32	16	8	4	2	1	SWL	81h (-127°C)
51h	Internal Temp High Limit	Sign	64	32	16	8	4	2	1	SWL	7Fh (+127°C)
52h	External Diode 2 Low Limit	Sign	64	32	16	8	4	2	1	SWL	81h (-127°C)
53h	External Diode 2 High Limit	Sign	64	32	16	8	4	2	1	SWL	7Fh (+127°C)
54h	External Diode 3 Low Limit	Sign	64	32	16	8	4	2	1	SWL	81h (-127°C)
55h	External Diode 3 High Limit	Sign	64	32	16	8	4	2	1	SWL	7Fh (+127°C)
56h	External Diode 4 Low Limit	Sign	64	32	16	8	4	2	1	SWL	81h (-127°C)
57h	External Diode 4 High Limit	Sign	64	32	16	8	4	2	1	SWL	7Fh (+127°C)
58h	External Diode 1A Low Limit	Sign	64	32	16	8	4	2	1	SWL	81h (-127°C)
59h	External Diode 1A High Limit	Sign	64	32	16	8	4	2	1	SWL	7Fh (+127°C)
5Ah	External Diode 2A Low Limit	Sign	64	32	16	8	4	2	1	SWL	81h (-127°C)
5Bh	External Diode 2A High Limit	Sign	64	32	16	8	4	2	1	SWL	7Fh (+127°C)
5Ch	External Diode 3A Low Limit	Sign	64	32	16	8	4	2	1	SWL	81h (-127°C)
5Dh	External Diode 3A High Limit	Sign	64	32	16	8	4	2	1	SWL	7Fh (+127°C)
5Eh	External Diode 4A Low Limit	Sign	64	32	16	8	4	2	1	SWL	81h (-127°C)
5Fh	External Diode 4A High Limit	Sign	64	32	16	8	4	2	1	SWL	7Fh (+127°C)

The [Environmental Monitor](#) contains both high and low limits for all temperature channels. The value is a 2's complement Temperature Value. If any particular temperature channel exceeds the high limit then the appropriate status bit is set. Likewise, if any particular temperature channel drops below the low limit, then the appropriate status bit is set.

MEC1725

The low limits can be used to detect diode fault conditions that are not explicitly detected by circuitry such as a short between DP and DN or a short of DP to ground or a short of DN to VTR. In all of these cases, the ADC will return a high byte value of 80h (diode fault) indicating that the delta V_{BE} is zero.

Note: The limit comparison is done with the diode reading value, including the fractional portion.

37.10.13 CONVERSION SECONDS RATE REGISTER

TABLE 37-33: CONVERSION SECONDS RATE REGISTER

ADDR	Register	B7	B6	B5	B4	B3	B2	B1	B0	Lock	Default
6Ch	Conversion Seconds Rate	RES	RES	RES	4	3	2	1	0	SWL	00h

Bits 4:0 - Conversion Seconds Rate - This controls the seconds counter for the conversion rate. This counter counts from 1 to 31 seconds.

0 = The counter is loaded for 32 seconds.

1-31 = Seconds Counter is enabled. A Round Robin Conversion starts every N seconds.

Note:

- When changing the Conversion Seconds Rate, the seconds counter is immediately forced to the new value. This means that even if the seconds counter was about to expire, the seconds counter will be reset to the newly programmed duration. The primary 1 second counter will not be reset so the 1st conversion rate can be up to 1 second less than what was programmed.
- This register is disabled when the [Conversion Configuration]:[Conversion Rate Mode] is programmed to 0 (default).

37.10.14 CONVERSION MODE REGISTER

TABLE 37-34: CONVERSION MODE REGISTER

ADDR	Register	B7	B6	B5	B4	B3	B2	B1	B0	Lock	Default
6Eh	Conversion Mode	RES	RES	RES	RES	RES	RES	Conversion Forced (Note 1)	Conversion Rate Mode	SWL	00h

Note 1: This bit is a self-clearing bit.

Bit 0 - Conversion Rate Mode - This selects which field defines the conversion rate.

When changing the mode from Multi-Second to Second Rate the seconds counter will be disabled, causing the conversion to occur on the next primary counter pulse.

Going from Second Rate to Multi-Second Rate will delay the Round Robin conversion until after the multi-second counter expires.

0: Second Rate - use the Conversion Rate as the time setting. (i.e., Bits 1:0 of the [Temperature Conversion Rate Configuration Register on page 530](#) determines the conversion rate.)

1: Multi-Second Rate - use the Conversion Seconds Rate setting. (i.e., Bits 4:0 of the [Conversion Seconds Rate Register on page 536](#) determine the conversion rate).

Note:

- Switching from Second Rate to Multi-Second Rate will not reset the primary (second) counter, so the 1st conversion may occur up to 1 second before the programmed delay. All subsequent conversions will occur at the programmed rate.
- Continuous Monitoring mode is only available when the Conversion Rate Mode is set to 0 (Second Rate).

Bit 1 - Conversion Forced - Overrides Conversion Rate Timer and forces an immediate conversion.

Once set, this bit will force the conversion rate timer to expire which will trigger a Round Robin conversion. This is a self-clear bit, which clears on the next cycle. This will also trigger the Conversion Counter Done IRQ.

0: No action

1: Force a conversion

37.10.15 REC ENABLE REGISTER

TABLE 37-35: REC ENABLE REGISTER

ADDR	Register	B7	B6	B5	B4	B3	B2	B1	B0	Lock	Default
70h	REC Enable	EN_R EC4A	EN_R EC3A	EN_R EC2A	EN_R EC1A	EN_R EC4	EN_R EC3	EN_R EC2	EN_R EC1	SWL	FFh

The REC Enable Register enables or disables the Resistance Error Correction circuitry for the corresponding external diode channel.

Note: REC should always be enabled, including for thermistors.

Bit 7 - EN_REC4A - Enables the REC circuitry on the External Diode 4A channel.

Bit 6 - EN_REC3A - Enables the REC circuitry on the External Diode 3A channel.

Bit 5 - EN_REC2A - Enables the REC circuitry on the External Diode 2A channel.

Bit 4 - EN_REC1A - Enables the REC circuitry on the External Diode 1A channel.

Bit 3 - EN_REC4 - Enables the REC circuitry on the External Diode 4 channel.

Bit 2 - EN_REC3 - Enables the REC circuitry on the External Diode 3 channel.

Bit 1 - EN_REC2 - Enables the REC circuitry on the External Diode 2 channel.

Bit 0 - EN_REC1 - Enables the REC circuitry on the External Diode 1 channel.

- '0' - Resistance Error Correction is disabled for External Diode x (if enabled).
- '1' - (default) The Resistance Error Correction circuitry is enabled for External Diode x.

37.10.16 THERMTRIP TEMPERATURE REGISTERS

TABLE 37-36: THERMTRIP TEMPERATURE REGISTERS

ADDR	Register	B7	B6	B5	B4	B3	B2	B1	B0	Lock	Default
75h	ThermTrip Temperature Diode 1	128	64	32	16	8	4	2	1	No	7Fh Note 1
80h	ThermTrip Temperature Diode 2	128	64	32	16	8	4	2	1	No	7Fh

MEC1725

TABLE 37-36: THERMTRIP TEMPERATURE REGISTERS (CONTINUED)

ADDR	Register	B7	B6	B5	B4	B3	B2	B1	B0	Lock	Default
81h	ThermTrip Temperature Diode 3	128	64	32	16	8	4	2	1	No	7Fh
82h	ThermTrip Temperature Diode 4	128	64	32	16	8	4	2	1	No	7Fh
83h	ThermTrip Temperature Diode 1A	128	64	32	16	8	4	2	1	No	7Fh
84h	ThermTrip Temperature Diode 2A	128	64	32	16	8	4	2	1	No	7Fh
85h	ThermTrip Temperature Diode 3A	128	64	32	16	8	4	2	1	No	7Fh
86h	ThermTrip Temperature Diode 4A	128	64	32	16	8	4	2	1	No	7Fh

Note 1: The Thermtrip Temperature for Diode 1 is set by VSET.

The ThermTrip Temperature Register Diode 1 is a Voltage Programmable Fail-Safe Temperature Monitor. The chip calculates a threshold temperature based on the VSET voltage and stores it in this register, as described in [Section 37.9.9, "Voltage Programmable Fail-Safe Temperature Monitor," on page 514](#). Software can later override the VSET-derived threshold if the OVRD bit is cleared. This register is programmed as 8-bit 2's complement Temperature Limit value.

If the External Diode Channel 1 is configured to operate as a thermistor input, then no calculations are done. In this case, ThermTrip Temperature Diode 1 will reflect the VSET voltage.

The ThermTrip Temperature Register Diode 2-4 registers are programmed as the 8-bit 2's complement Temperature Limit value for External Ch2-4. If the Reading exceeds this value the External Ch2-4 Shutdown Status bit will be set.

When Diodes 1-4 are replaced with thermistors, the limit is a voltage value and applies to the thermistor.

The ThermTrip Temperature Register Diode 1A-4A registers are programmed as the 8-bit 2's complement Temperature Limit value for External Ch1A-4A. If the Reading exceeds this value the External Ch1A-4A Shutdown Status bit will be set.

37.10.17 FAILSAFE STATUS REGISTER

TABLE 37-37: FAILSAFE STATUS REGISTER

ADDR	Register	B7	B6	B5	B4	B3	B2	B1	B0	Lock	Default
76h	FailSafe Status	RES	RES	RES	RES	Test	Test	Test	HWFS	No	00h

The FailSafe Status Register is a read-only register that indicates that the ThermTrip logic block was responsible for causing the SYS_SHDN# signal to be asserted. This register and the FailSafe Configuration Register are unique in that they are powered from the VBAT pin so that if power is removed from the VTR pin, these registers will not be reset.

In this register, the HWFS bit is set to '1' when the corresponding signal is asserted low. Once set, the bit remains set until cleared by writing to the CFS bit in the Special Function Register. Note that clearing the bit in this register will not cause the SYS_SHDN# pin to deassert. The [The SYS_SHDN# pin will not assert while PWRGD_IN is de-asserted](#),

even if the Environmental Monitor is in the Run state. However, once SYS_SHDN# asserted, it will remain active low until SYS_SHDN_RST1# or SYS_SHDN_RST2 asserts. In addition, deasserting the SYS_SHDN# pin will not cause the bit in this register to be cleared.

This register will not be updated if the PWRGD_IN signal is not asserted.

Bit[7:4] Reserved

Bit 3 - Test

Bit 2 - Test

Bit 1 - Test

Bit 0 - HWFS - indicates that the internal HW_FAILSAFE# signal for one of the enabled diodes has exceeded its failsafe limit. See Section 37.10.19, "Shutdown Status Register," on page 539.

37.10.18 FAILSAFE CONFIGURATION REGISTER

TABLE 37-38: FAILSAFE CONFIG REGISTER

ADDR	Register	B7	B6	B5	B4	B3	B2	B1	B0	Lock	Default
77h	FailSafe Config	RES	RES	RES	RES	RES	RES	RES	LPM	SWL	00h

The FailSafe Configuration Register stores configuration bits that are retained across all power mode including the VBAT Power Mode. This register and the FailSafe Status Register are unique in that they are powered from the VBAT pin so that if power is removed from the VTR pin, these registers will not be reset.

Bit[7:1] Reserved

Bit 0 - LPM - Determines whether the Environmental Monitor is placed into sleep mode when the PWRGD_IN signal is de-asserted. In this case, the SYS_SHDN# pin (if enabled) will be blocked.

- '0' (default) - The Low Power Mode is not enabled. When the PWRGD_IN signal is de-asserted, all hardware monitoring will cease.
- '1' - The Low Power Mode is enabled. When the PWRGD_IN signal is de-asserted, the hardware monitoring will continue to function.

37.10.19 SHUTDOWN STATUS REGISTER

TABLE 37-39: SHUTDOWN STATUS REGISTER

ADDR	Register	B7	B6	B5	B4	B3	B2	B1	B0	Lock	Default
78h	Shutdown Status	D4A	D3A	D2A	D1A	D4	D3	D2	D1	No	00h

The Shutdown Status Register is a read-only register that indicates which diode was responsible for causing the SYS_SHDN# signal to be asserted when it exceeded its thermtrip limit. This register is powered from the VBAT pin so that if power is removed from the VTR pin, this register will not be reset.

In this register, each bit is set to '1' when the corresponding input pin (or signal) is asserted low. Once set, the bits remain set until they are cleared by writing to the CFS bit in the Special Function Register.

This register will not be updated if the PWRGD_IN signal is not asserted.

Bit 7 - D4A - indicates that the D4A temperature exceeded its thermtrip temperature limit.

Bit 6 - D3A - indicates that the D3A temperature exceeded its thermtrip temperature limit.

Bit 5 - D2A - indicates that the D2A temperature exceeded its thermtrip temperature limit.

Bit 4 - D1A - indicates that the D1A temperature exceeded its thermtrip temperature limit.

MEC1725

Bit 3 - D4 - indicates that the D4 temperature exceeded its thermtrip temperature limit.

Bit 2 - D3 - indicates that the D3 temperature exceeded its thermtrip temperature limit.

Bit 1 - D2 - indicates that the D2 temperature exceeded its thermtrip temperature limit.

Bit 0 - D1 - indicates that the D1 temperature exceeded its thermtrip temperature limit.

37.10.20 SHUTDOWN CONFIGURATION REGISTER

TABLE 37-40: SHUTDOWN CONFIG REGISTER

ADDR	Register	B7	B6	B5	B4	B3	B2	B1	B0	Lock	Default
79h	Shutdown Config	D4A	D3A	D2A	D1A	D4	D3	D2	D1	SWL	01h

Note: The bits in this register can only be written when **PWRGD_IN** is set to '1'.

The Shutdown Configuration Register stores configuration bits that are retained across all power modes including the VBAT Power Mode. This register is powered from the VBAT pin so that if power is removed from the VTR pin, this register will not be reset.

Bit 7 - D4A - When this bit is set, the SYS_SHDN# pin will assert when the D4A temperature exceeds its thermtrip temperature limit.

Bit 6 - D3A - When this bit is set, the SYS_SHDN# pin will assert when the D3A temperature exceeds its thermtrip temperature limit.

Bit 5 - D2A - When this bit is set, the SYS_SHDN# pin will assert when the D2A temperature exceeds its thermtrip temperature limit.

Bit 4 - D1A - When this bit is set, the SYS_SHDN# pin will assert when the D1A temperature exceeds its thermtrip temperature limit.

Bit 3 - D4 - When this bit is set, the SYS_SHDN# pin will assert when the D4 temperature exceeds its thermtrip temperature limit.

Bit 2 - D3 - When this bit is set, the SYS_SHDN# pin will assert when the D3 temperature exceeds its thermtrip temperature limit.

Bit 1 - D2 - When this bit is set, the SYS_SHDN# pin will assert when the D2 temperature exceeds its thermtrip temperature limit.

Bit 0 - D1 - When this bit is set, the SYS_SHDN# pin will assert when the D1 temperature exceeds its thermtrip temperature limit.

Bit definition:

- 0: disable
- 1: enable.

37.10.21 INTERRUPT ENABLE REGISTERS

TABLE 37-41: INTERRUPT ENABLE REGISTERS

ADDR	Register	B7	B6	B5	B4	B3	B2	B1	B0	Lock	Default
7Ah	Fault Interrupt Enable Register	RES	RES	RES	RES	ERR4	ERR3	ERR2	ERR1	SWL	00h
7Bh	Temp Interrupt Enable Register	TRD4 A	TRD3 A	TRD2 A	TRD1 A	TRD4	TRD3	TRD2	TRD1	SWL	00h

TABLE 37-41: INTERRUPT ENABLE REGISTERS

ADDR	Register	B7	B6	B5	B4	B3	B2	B1	B0	Lock	Default
7Dh	Int Temp Interrupt Enable Register	RES	RES	RES	RES	RES	RES	RES	TINT	SWL	00h
7Eh	Volt Interrupt Enable Register	RES	RES	RES	CONV CNT DONE	VIN	VTR	Test	VTT	SWL	00h

The Interrupt Enable Registers determine which interrupt events will update the status registers. If a condition or channel is not enabled, then any error conditions associated with it will be ignored.

37.10.21.1 Fault Interrupt Enable Register (7Ah)

Bit[7:4] - Reserved

Bit[3:0] - ERR[4:1] - This bit enables an interrupt for a diode fault error on External Diode [4:1].

37.10.21.2 Temp Interrupt Enable Register (7Bh)

Bit[7:4] - TRD[4:1]A - Enables an interrupt for an External Diode [4:1]A out-of-limit condition.

Bit[3:0] - TRD[4:1] - Enables an interrupt for an External Diode [4:1] out-of-limit condition. This includes the THERM measurement channel when enabled.

37.10.21.3 Int Temp Interrupt Enable Register (7Dh)

Bit [7:1] Reserved

Bit 0 - INT - enables Internal diode interrupts.

37.10.21.4 Voltage Interrupt Status Enable Register (7Eh)

Bit [7:5] Reserved

Bit 4 - CONV CNT DONE - enables Conversion Count Done based interrupts.

Bit 3 - VIN - enables VIN based interrupts.

Bit 2 - VTR - enables VTR based interrupts.

Bit 1 - Test

Bit 0 - VTT - enables VTT based interrupts.

37.10.22 SPECIAL FUNCTION REGISTER

TABLE 37-42: SPECIAL FUNCTION REGISTER

ADDR	Register	B7	B6	B5	B4	B3	B2	B1	B0	Lock	Default
7Ch	Special Function Register	RES	RES	RES	RES	CFS	RES	RES	OVRD	No	00h

The Special Function Register controls the Failsafe Status register, the Shutdown Status Register and the ThermTrip Status register.

Bit [7:4] - Reserved - This bit is always '0'.

APPLICATION NOTE: The CFS bit requires [PWRGD_IN](#) to be asserted before it will clear the Failsafe Status Register. This applies to both Standby and Low Power modes. If the bit is set while the

MEC1725

PWRGD_IN signal is de-asserted, it will remain set and clear the Failsafe Status Register when the PWRGD_IN signal is asserted.

Bit 3 - CFS - clears the Failsafe Status register and the Shutdown Status Register. When set to '1', the FailSafe Status register and the Shutdown Status Register is cleared and reset to default values. This bit is NOT self clearing and must be set to '0' in order for the FailSafe Status register and the Shutdown Status Register to function correctly. No delay is required between successive writes of the CFS bit.

Bit [2:1] - Reserved - This bit is always '0'.

Bit 0 - OVRD - This bit disables write protection of the ThermTrip threshold for Diode 1.

- '0' (default) - The ThermTrip Temperature Diode 1 register is read-only and Diode 1 cannot be disabled from Fail-Safe Monitoring
- '1' -The ThermTrip Temperature Diode 1 register is read-write and Diode 1 can be disabled from FailSafe Monitoring

37.10.23 ADJUST CH1-4 REGISTERS

TABLE 37-43: ADJUST CH1-4 REGISTERS

ADDR	Register	B7	B6	B5	B4	B3	B2	B1	B0	Default
88h	Adjust Ch1	RES	ADJUST_EXT_CH1[6:0]						00h	
89h	Adjust Ch2	RES	ADJUST_EXT_CH2[6:0]						00h	
8Ah	Adjust Ch3	RES	ADJUST_EXT_CH3[6:0]						00h	
8Bh	Adjust Ch4	RES	ADJUST_EXT_CH4[6:0]						00h	

These registers contain Adjust values for External Channel 1-4.

The Adjust Ch 1-4 Registers hold a value that is automatically applied to the External Diode channel. This 7-bit adjust value may be used to correct offsets and errors caused by external diode ideality factors that do not match the internally calibrated value.

ADJUST_EXT_CH1[6:0] - 2's Complement adjustment value for TR Trim to be used for External Ch1.

Note: ADJUST must be set so that the result does not roll over to be a negative number.

ADJUST_EXT_CH2[6:0] - 2's Complement adjustment value to be used for External Ch2.

ADJUST must be set so that the result does not roll over to be a negative number.

ADJUST_EXT_CH3[6:0] - 2's Complement adjustment value to be used for External Ch3.

ADJUST must be set so that the result does not roll over to be a negative number.

ADJUST_EXT_CH4[6:0] - 2's Complement adjustment value to be used for External Ch4.

ADJUST must be set so that the result does not roll over to be a negative number.

37.10.24 ADJUST CH1A-4A REGISTERS

TABLE 37-44: ADJUST CH1A-4A REGISTERS

ADDR	Register	B7	B6	B5	B4	B3	B2	B1	B0	Default
8Ch	Adjust Ch1A	RES	ADJUST_EXT_CH1A[6:0]						00h	
8Dh	Adjust Ch2A	RES	ADJUST_EXT_CH2A[6:0]						00h	
8Eh	Adjust Ch3A	RES	ADJUST_EXT_CH3A[6:0]						00h	
8Fh	Adjust Ch4A	RES	ADJUST_EXT_CH4A[6:0]						00h	

These registers contain EMC IP Trim Adjust values for External Channel 1A-14A.

TR_ADJUST_EXT_CH1A[6:0] - 2's Complement adjustment value to be used for External Ch1A.

Note: ADJUST must be set so that the result does not roll over to be a negative number.

ADJUST_EXT_CH2A[6:0] - 2's Complement adjustment value to be used for External Ch2A.

Note: ADJUST must be set so that the result does not roll over to be a negative number.

ADJUST_EXT_CH3A[6:0] - 2's Complement adjustment value to be used for External Ch3A.

Note: ADJUST must be set so that the result does not roll over to be a negative number.

ADJUST_EXT_CH4A[6:0] - 2's Complement adjustment value to be used for External Ch4A.

Note: ADJUST must be set so that the result does not roll over to be a negative number.

37.10.25 ADJUST INTERNAL REGISTERS

TABLE 37-45: ADJUST INTERNAL REGISTERS

ADDR	Register	B7	B6	B5	B4	B3	B2	B1	B0	Default
90h	Adjust Internal	RES	ADJUST_INT_TEMP[6:0]							00h
91h	Adjust VSET	RES	ADJUST_VSET[6:0]							00h
92h	Adjust Res Byte 3	RES	RES	RES	RES	RES	RES	RES	RES	00h
93h	Adjust Res Byte 4	RES	RES	RES	RES	RES	RES	RES	RES	00h

These registers contain Adjust values for Internal Temp and VSET.

ADJUST_INT_TEMP[6:0] - 2's Complement adjustment value to be used for Internal Temp.

Note: ADJUST must be set so that the result does not roll over to be a negative number.

ADJUST_VSET[6:0] - 2's Complement adjustment value to be used for VSET.

Note: ADJUST must be set so that the result does not roll over to be a negative number.

37.10.26 ADJUST VOLTAGE CHS REGISTERS

TABLE 37-46: ADJUST VOLTAGE CHS REGISTERS

ADDR	Register	B7	B6	B5	B4	B3	B2	B1	B0	Default
94h	Test	RES	Test	Test	Test	Test	Test	Test	Test	00h
95h	Adjust VIN	RES	ADJUST_VIN[6:0]							00h
96h	Adjust VTR	RES	ADJUST_VTR[6:0]							00h
97h	Adjust VTT	RES	ADJUST_VTT[6:0]							00h

These registers contain Adjust values for Voltage Channels.

ADJUST_VIN[6:0] - 2's Complement adjustment value to be used for VIN.

ADJUST must be set so that the result does not roll over to be a negative number.

ADJUST_VTR[6:0] - 2's Complement adjustment value to be used for VTR.

ADJUST must be set so that the result does not roll over to be a negative number.

MEC1725

ADJUST_VTT[6:0] - 2's Complement adjustment value to be used for VTT.

ADJUST must be set so that the result does not roll over to be a negative number.

37.10.27 UNLOCK REGISTER

TABLE 37-47: UNLOCK REGISTER

ADDR	Register	B7	B6	B5	B4	B3	B2	B1	B0	Default
FCh	Unlock	RES	RES	RES	RES	RES	RES	RES	UNLOCK	00h

UNLOCK: This bit unlocks the LOCK bit located in Bit 1 of the [Lock Start Register on page 532](#).

0: Bit 1 LOCK is locked normally by itself.

1: Bit 1 LOCK is R/W accessible no matter how the LOCK bit is set.

37.10.28 SYSTEM SHUTDOWN RESET REGISTER

TABLE 37-48: SYSTEM SHUTDOWN RESET REGISTER

ADDR	Register	B7	B6	B5	B4	B3	B2	B1	B0	Default
400h	System Shutdown Reset	RES	RES	RES	RES	RES	RES	RES	SYS_SHD-N_RST	00h

SYS_SHDN_RST: The SYS_SHDN# output is de-asserted within a clock cycle on the rising edge of this bit. The bit is not self clearing and must be reset to '0' by firmware. No delay is required between successive writes to this bit.

38.0 QUAD SPI MASTER CONTROLLER

38.1 Overview

The Quad SPI Master Controller may be used to communicate with various peripheral devices that use a Serial Peripheral Interface, such as EEPROMS, DACs and ADCs. The controller can be configured to support advanced SPI Flash devices with multi-phase access protocols. Data can be transferred in Half Duplex, Single Data Rate, Dual Data Rate and Quad Data Rate modes. In all modes and all SPI clock speeds, the controller supports back-to-back reads and writes without clock stretching if internal bandwidth permits.

38.2 References

No references have been cited for this feature.

38.3 Terminology

No terminology for this block.

38.4 Interface

This block is designed to be accessed externally via the pin interface and internally via a registered host interface.

FIGURE 38-1: I/O DIAGRAM OF BLOCK

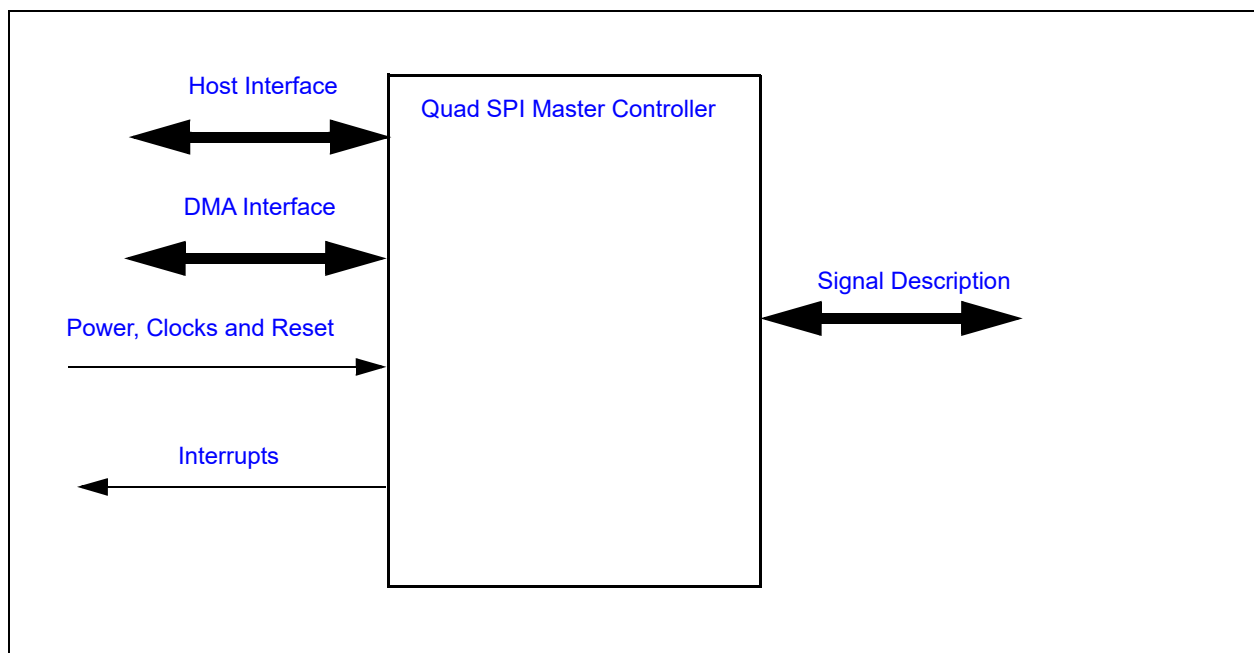

38.5 Signal Description

TABLE 38-1: EXTERNAL SIGNAL DESCRIPTION

Name	Direction	Description
SPI_CLK	Output	SPI Clock output used to drive the SPCLK pin.
SPI_CS#	Output	SPI chip select
SPI_IO0	Input/Output	SPI Data pin 0. Also used as SPI_MOSI, Master-Out/Slave-In when the interface is used in Single wire mode
SPI_IO1	Input/Output	SPI Data pin 1. Also used as SPI_MISO, Master-In/Slave-Out when the interface is used in Single wire mode

MEC1725

TABLE 38-1: EXTERNAL SIGNAL DESCRIPTION (CONTINUED)

Name	Direction	Description
SPI_IO2	Input/Output	SPI Data pin 2 when the SPI interface is used in Quad Mode. Also can be used by firmware as WP.
SPI_IO3	Input/Output	SPI Data pin 3 when the SPI interface is used in Quad Mode. Also can be used by firmware as HOLD.

38.6 Host Interface

The registers defined for the General Purpose Serial Peripheral Interface are accessible by the various hosts as indicated in [Section 3.2, "Block Overview and Base Addresses"](#).

38.7 DMA Interface

This block is designed to communicate with the Internal DMA Controller.

Note: For a description of the Internal DMA Controller implemented in this design see [Section 7.0, "Internal DMA Controller"](#).

38.8 Power, Clocks and Reset

This section defines the Power, Clock, and Reset parameters of the block.

38.8.1 POWER

Name	Description
VTR_CORE	The logic and registers implemented in this block are powered by this power well.

38.8.2 CLOCKS

Name	Description
96 MHz	This is a clock source for the SPI clock generator.

38.8.3 RESETS

Name	Description
RESET_SYS	This signal resets all the registers and logic in this block to their default state. QMSPI Status Register
RESET	This reset is generated if either the RESET_SYS is asserted or the SOFT_RESET is asserted.

38.9 Interrupts

This section defines the Interrupt Sources generated from this block.

Source	Description
QMSPI_INT	Interrupt generated by the Quad SPI Master Controller. Events that may cause the interrupt to be asserted are stored in the QMSPI Status Register .

38.10 Low Power Modes

The Quad SPI Master Controller is always in its lowest power state unless a transaction is in process. A transaction is in process between the time the START bit is written with a '1' and the TRANSFER_DONE bit is set by hardware to '1'. If the QMSPI SLEEP_ENABLE input is asserted, writes to the START bit are ignored and the Quad SPI Master Controller will remain in its lowest power state.

38.11 Description

- Support for multiple SPI pin configurations
 - Single wire half duplex
 - Two wire full duplex
 - Two wire double data rate
 - Four wire quad data rate
- Separate FIFO buffers for Receive and Transmit
 - 8 byte FIFO depth in each FIFO
 - Each FIFO can be 1 byte, 2 bytes or 4 bytes wide
- Support for all four SPI clock formats
- Programmable SPI Clock generator, with clock polarity and phase controls
- Separate DMA support for Receive and Transmit data transfers
- Configurable interrupts, for errors, individual bytes, or entire transactions
- Descriptor Mode, in which a set of sixteen descriptor registers can configure the controller to autonomously perform multi-phase SPI data transfers
- Capable of wire speed transfers in all SPI modes and all configurable SPI clock rates (internal bus contention may cause clock stretching)

FIGURE 38-2: QUAD MASTER SPI BLOCK DIAGRAM

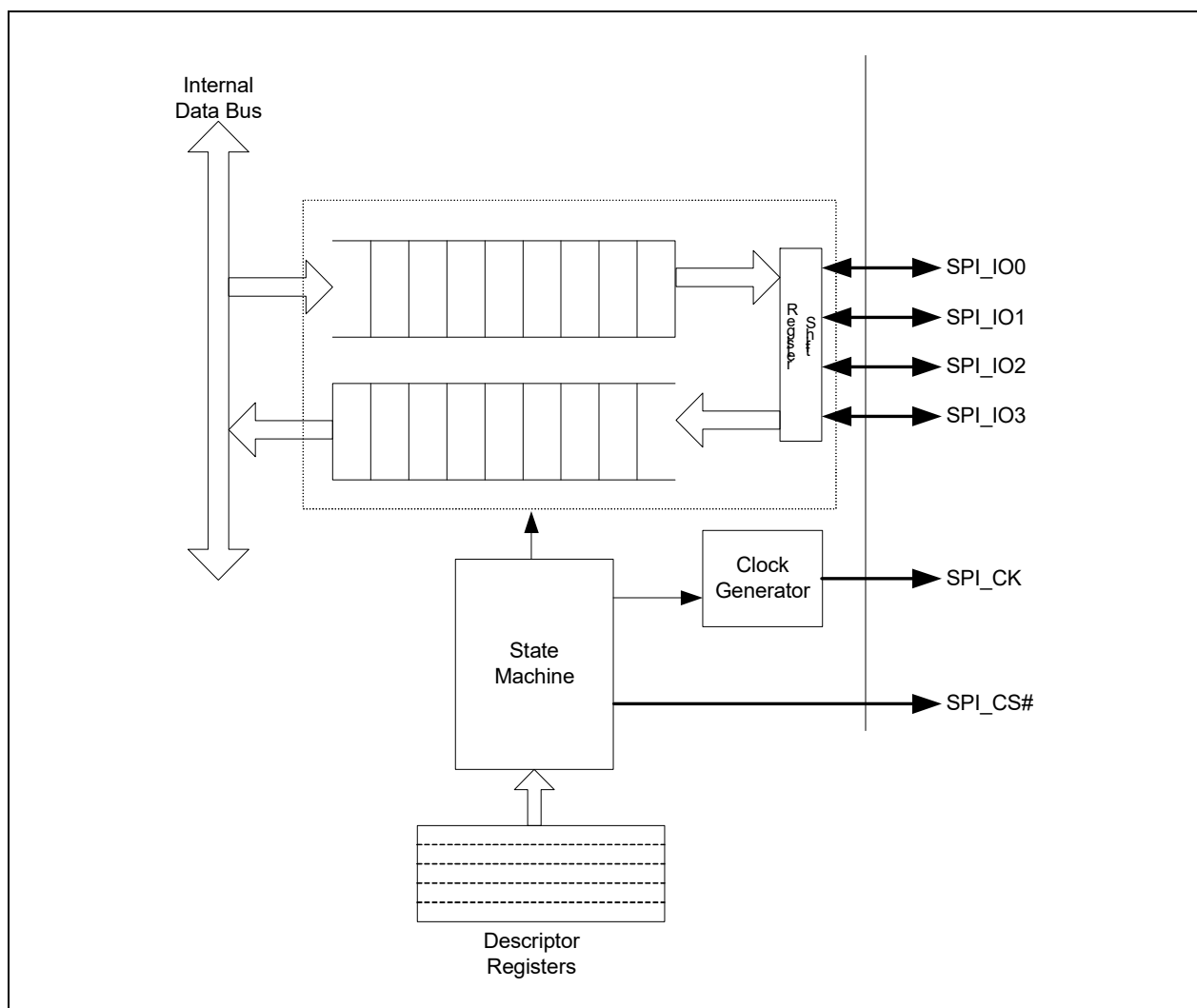

38.11.1 SPI CONFIGURATIONS MODES

- Half Duplex. All SPI data transfers take place on a single wire, SPI_IO0
- Full Duplex. This is the legacy SPI configuration, where all SPI data is transferred one bit at a time and data from the SPI Master to the SPI Slave takes place on SPI_MOSI (SPI_IO0) and at the same time data from the SPI Slave to the SPI Master takes place on SPI_MISO (SPI_IO1)
- Dual Data Rate. Data transfers between the SPI Master and the SPI Slave take place two bits at a time, using SPI_IO0 and SPI_IO1
- Quad Data Rate. Data transfers between the SPI Master and the SPI Slave take place four bits at a time, using all four SPI data wires, SPI_IO0, SPI_IO1, SPI_IO2 and SPI_IO3

38.11.2 SPI CONTROLLER MODES

- Manual. In this mode, firmware control all SPI data transfers byte at a time
- DMA. Firmware configures the SPI Master controller for characteristics like data width but the transfer of data between the FIFO buffers in the SPI controller and memory is controlled by the DMA controller. DMA transfers can take place from the Slave to the Master, from the Master to the Slave, or in both directions simultaneously
- Descriptor. Descriptor Mode extends the SPI Controller so that firmware can configure a multi-phase SPI transfer, in which each phase may have a different SPI bus width, a different direction, and a different length. For example, firmware can configure the controller so that a read from an advanced SPI Flash, which consists of a command phase, an address phase, a dummy cycle phase and the read phase, can take place as a single operation, with a single interrupt to firmware when the entire transfer is completed
- Local DMA. Supports local Rx and Tx DMA channels to transfer data at high rates.

38.11.3 SPI CLOCK

The SPI output clock is derived from the 96 MHz, divided by a value programmed in the [CLOCK_DIVIDE](#) field of the [QMSPI Mode Register](#). Sample frequencies are shown in the following table:

TABLE 38-2: EXAMPLE SPI FREQUENCIES

CLOCK_DIVIDE	SPI Clock Frequency
0	375 KHz
1	96 MHz
2	48 MHz
3	36 MHz
6	16 MHz
48	2 MHz
128	750 KHz
255	376.5 KHz

38.11.4 ERROR CONDITIONS

The Quad SPI Master Controller can detect some illegal configurations. When these errors are detected, an error is signaled via the [PROGRAMMING_ERROR](#) status bit. This bit is asserted when any of the following errors are detected:

- Both Receive and the Transmit transfers are enabled when the SPI Master Controller is configured for Dual Data Rate or Quad Data Rate
- Both Pull-up and Pull-down resistors are enabled on either the Receive data pins or the Transmit data pins
- The transfer length is programmed in bit mode, but the total number of bits is not a multiple of 2 (when the controller is configured for Dual Data Rate) or 4 (when the controller is configured for Quad Data Rate)
- Both the [STOP](#) bit and the [START](#) bits in the [QMSPI Execute Register](#) are set to '1' simultaneously

38.12 EC Registers

Registers for this block are shown in the following summary table. Addresses for each register are determined by adding the offset to the Base Address for each instance of the [Quad SPI Master Controller](#) Block in the Block Overview and Base Address Table in [Section 3.0, "Device Inventory"](#).

TABLE 38-3: REGISTER SUMMARY

Offset	Register Name
0h	QMSPI Mode Register
4h	QMSPI Control Register
8h	QMSPI Execute Register
Ch	QMSPI Interface Control Register
10h	QMSPI Status Register
14h	QMSPI Buffer Count Status Register
18h	QMSPI Interrupt Enable Register
1Ch	QMSPI Buffer Count Trigger Register
20h	QMSPI Transmit Buffer Register
24h	QMSPI Receive Buffer Register
28h	QMSPI Chip Select Timing Register
30h	QMSPI Description Buffer 0 Register
34h	QMSPI Description Buffer 1 Register
38h	QMSPI Description Buffer 2 Register
3Ch	QMSPI Description Buffer 3 Register
40h	QMSPI Description Buffer 4 Register
44h	QMSPI Description Buffer 5 Register
48h	QMSPI Description Buffer 6 Register
4Ch	QMSPI Description Buffer 7 Register
50h	QMSPI Description Buffer 8 Register
54h	QMSPI Description Buffer 9 Register
58h	QMSPI Description Buffer 10 Register
5Ch	QMSPI Description Buffer 11 Register
60h	QMSPI Description Buffer 12 Register
64h	QMSPI Description Buffer 13 Register
68h	QMSPI Description Buffer 14 Register
6Ch	QMSPI Description Buffer 15 Register
B0	Test
C0	QMSPI Mode Alternate1 Register
D0	Test
D4	QMSPI Taps Adjustment Register
D8	Test
100h	QMSPI Descriptor Local DMA Rx Enable Register
104h	QMSPI Descriptor Local DMA Tx Enable Register
110h	QMSPI Local DMA Rx Control Channel 0 Register
114h	QMSPI Local DMA Rx Start Address Channel 0 Register
118h	QMSPI Local DMA Rx Length Channel 0 Register
11Ch	Reserved
120h	QMSPI Local DMA Rx Control Channel 1 Register

TABLE 38-3: REGISTER SUMMARY (CONTINUED)

Offset	Register Name
124h	QMSPI Local DMA Rx Start Address Channel 1 Register
128h	QMSPI Local DMA Rx Length Channel 1 Register
12Ch	Reserved
120h	QMSPI Local DMA Rx Control Channel 2 Register
124h	QMSPI Local DMA Rx Start Address Channel 2 Register
128h	QMSPI Local DMA Rx Length Channel 2 Register
12Ch	Reserved
140h	QMSPI Local DMA Tx Control Channel 0 Register
144h	QMSPI Local DMA Tx Start Address Channel 0 Register
148h	QMSPI Local DMA Tx Length Channel 0 Register
14Ch	Reserved
150h	QMSPI Local DMA Tx Control Channel 1 Register
154h	QMSPI Local DMA Tx Start Address Channel 1 Register
158h	QMSPI Local DMA Tx Length Channel 1 Register
15Ch	Reserved
160h	QMSPI Local DMA Tx Control Channel 2 Register
164h	QMSPI Local DMA Tx Start Address Channel 2 Register
168h	QMSPI Local DMA Tx Length Channel 2 Register
16Ch	Reserved

38.12.1 QMSPI MODE REGISTER

Offset	00h			
Bits	Description	Type	Default	Reset Event
31:24	Reserved	RES	-	-
23:16	CLOCK_DIVIDE The SPI clock divide in number of system clocks. A value of 1 divides the master clock by 1, a value of 255 divides the master clock by 255. A value of 0 divides the master clock by 256. See Table 38-2, "Example SPI Frequencies" for examples.	R/W	0h	RESET
15:14	Reserved	RES	-	-
13:12	CHIP_SELECT Selects which Chip Select line is active. The non-active CS line is driven high. 00=Chip Select 0 01=Chip Select 1 1x=unused.	R/W	0h	RESET
11	Reserved	RES	-	-

Offset	00h			
Bits	Description	Type	Default	Reset Event
10	<p>CHPA_MISO</p> <p>If CPOL=1: 1=Data are captured on the rising edge of the SPI clock 0=Data are captured on the falling edge of the SPI clock</p> <p>If CPOL=0: 1=Data are captured on the falling edge of the SPI clock 0=Data are captured on the rising edge of the SPI clock</p> <p>Application Notes: Common SPI Mode configurations: Common SPI Modes require the CHPA_MISO and CHPA_MOSI programmed to the same value. E.g.,</p> <ul style="list-style-type: none"> - Mode 0: CPOL=0; CHPA_MISO=0; CHPA_MOSI=0 - Mode 3: CPOL=1; CHPA_MISO=1; CHPA_MOSI=1 <p>Alternative SPI Mode configurations When configured for quad mode, applications operating at 48MHz may find it difficult to meet the minimum setup timing using the default Mode 0. It is recommended to configure the Master to sample and change data on the same edge when operating at 48MHz as shown in these examples. E.g.,</p> <ul style="list-style-type: none"> - Mode 0: CPOL=0; CHPA_MISO=1; CHPA_MOSI=0 - Mode 3: CPOL=1; CHPA_MISO=0; CHPA_MOSI=1 	R/W	0h	RESET
9	<p>CHPA_MOSI</p> <p>If CPOL=1: 1=Data changes on the falling edge of the SPI clock 0=Data changes on the rising edge of the SPI clock</p> <p>If CPOL=0: 1=Data changes on the rising edge of the SPI clock 0=Data changes on the falling edge of the SPI clock</p>	R/W	0h	RESET
8	<p>CPOL</p> <p>Polarity of the SPI clock line when there are no transactions in process.</p> <p>1=SPI Clock starts High 0=SPI Clock starts Low</p>	R/W	0h	RESET
7:5	Reserved	RES	-	-
4	<p>Local DMA Tx Enable</p> <p>This enables the Local DMA usage (instead of the Central DMA) when the Control register enables the DMA.</p> <p>0 = Central DMA for Tx DMA Enable 1 = Local DMA for Tx DMA Enable</p>	R/W	0h	RESET
3	<p>Local DMA Rx Enable</p> <p>This enables the Local DMA usage (instead of the Central DMA) when the Control register enables the DMA.</p> <p>0 = Central DMA for Rx DMA Enable 1 = Local DMA for Rx DMA Enable</p>	R/W	0h	RESET

MEC1725

Offset	00h			
Bits	Description	Type	Default	Reset Event
2	SAF DMA Mode This mode enables the H/W to allow a DMA to access the part with accesses that are not a multiple of 4 bytes. 0 = Standard DMA functionality 1 = SAF DMA Mode: Non-standard DMA functionality with arbitrary (unaligned) sizes and FIFO underflow allowed.	R/W	0h	RESET
1	SOFT_RESET Writing this bit with a '1' will reset the Quad SPI block. It is self-clearing.	W	0h	RESET_SYS
0	ACTIVATE 1=Enabled. The block is fully operational 0=Disabled. Clocks are gated to conserve power and the output signals are set to their inactive state	R/W	0h	RESET

38.12.2 QMSPI CONTROL REGISTER

Offset	04h			
Bits	Description	Type	Default	Reset Event
31:17	TRANSFER_LENGTH The length of the SPI transfer. The count is in bytes or bits, depending on the value of TRANSFER_UNITS . A value of '0' means an infinite length transfer.	R/W	0h	RESET
16	DESCRIPTION_BUFFER_ENABLE This enables the Description Buffers to be used. 1=Description Buffers in use. The first buffer is defined in DESCRIPTION_BUFFER_POINTER 0=Description Buffers disabled	R/W	0h	RESET
15:12	DESCRIPTION_BUFFER_POINTER This field selects the first buffer used if Description Buffers are enabled.	R/W	0h	RESET
11:10	TRANSFER_UNITS 3= TRANSFER_LENGTH defined in units of 16-byte segments 2= TRANSFER_LENGTH defined in units of 4-byte segments 1= TRANSFER_LENGTH defined in units of bytes 0= TRANSFER_LENGTH defined in units of bits	R/W	0h	RESET
9	CLOSE_TRANSFER_ENABLE This selects what action is taken at the end of a transfer. When the transaction closes, the Chip Select de-asserts, the SPI interface returns to IDLE and the DMA transfer terminates. When Description Buffers are in use this bit must be set only on the Last Buffer. 1=The transaction is terminated 0=The transaction is not terminated	R/W	0h	RESET
8:7	RX_DMA_ENABLE This bit enables DMA support for Receive Transfer. If enabled, DMA will be requested to empty the FIFO until either the interface reaches TRANSFER_LENGTH or the DMA sends a termination request. The size defined here must match DMA programmed access size. 1=DMA is enabled and set to 1 Byte 2=DMA is enabled and set to 2 Bytes 3=DMA is enabled and set to 4 Bytes 0=DMA is disabled. All data in the Receive Buffer must be emptied by firmware When the local DMA is in use: This selects what channel of the local Rx DMA is selected. If 0, DMA is disabled. If 1-3 local Rx DMA channel 1-3 is selected.	R/W	0h	RESET
6	RX_TRANSFER_ENABLE This bit enables the receive function of the SPI interface. 1=Receive is enabled. Data received from the SPI Slave is stored in the Receive Buffer 0=Receive is disabled	R/W	0h	RESET

MEC1725

Offset	04h			
Bits	Description	Type	Default	Reset Event
5:4	<p>TX_DMA_ENABLE</p> <p>This bit enables DMA support for Transmit Transfer. If enabled, DMA will be requested to fill the FIFO until either the interface reaches TRANSFER_LENGTH or the DMA sends a termination request. The size defined here must match DMA programmed access size.</p> <p>1=DMA is enabled and set to 1 Byte 2=DMA is enabled and set to 2 Bytes 3=DMA is enabled and set to 4 Bytes 0=DMA is disabled. All data in the Transmit Buffer must be emptied by firmware</p> <p>When the local DMA is in use: This selects what channel of the local Tx DMA is selected. If 0, DMA is disabled. If 1-3 local Tx DMA channel 1-3 is selected.</p>	R/W	0h	RESET
3:2	<p>TX_TRANSFER_ENABLE</p> <p>This field bit selects the transmit function of the SPI interface.</p> <p>3=Transmit Enabled in 1 Mode. The MOSI or IO Bus will send out only 1's. The Transmit Buffer will not be used 2=Transmit Enabled in 0 Mode. The MOSI or IO Bus will send out only 0's. The Transmit Buffer will not be used. 1=Transmit Enabled. Data will be fetched from the Transmit Buffer and sent out on the MOSI or IO Bus. 0=Transmit is Disabled. Not data is sent. This will cause the MOSI be to be undriven, or the IO bus to be undriven if Receive is also disabled.</p>	R/W	0h	RESET
1:0	<p>INTERFACE_MODE</p> <p>This field sets the transmission mode. If this field is set for Dual Mode or Quad Mode then either TX_TRANSFER_ENABLE or RX_TRANSFER_ENABLE must be 0.</p> <p>3=Reserved 2=Quad Mode 1=Dual Mode 0=Single/Duplex Mode</p>	R/W	0h	RESET

38.12.3 QMSPI EXECUTE REGISTER

Offset	08h			
Bits	Description	Type	Default	Reset Event
31:3	Reserved	RES	-	-
2	<p>CLEAR_DATA_BUFFER</p> <p>Writing a '1' to this bit will clear out the Transmit and Receive FIFOs. Any data stored in the FIFOs is discarded and all count fields are reset. Writing a '0' to this bit has no effect. This bit is self-clearing.</p>	W	0h	RESET

Offset	08h			
Bits	Description	Type	Default	Reset Event
1	STOP Writing a '1' to this bit will stop any transfer in progress at the next byte boundary. Writing a '0' to this bit has no effect. This bit is self-clearing. After the transfer has stopped, the controller will de-assert chip-select to terminate the transfer over the SPI interface This bit must not be set to '1' if the field START in this register is set to '1'.	W	0h	RESET
0	START Writing a '1' to this bit will start the SPI transfer. Writing a '0' to this bit has no effect. This bit is self-clearing. This bit must not be set to '1' if the field STOP in this register is set to '1'.	W	0h	RESET

38.12.4 QMSPI INTERFACE CONTROL REGISTER

Offset	0Ch			
Bits	Description	Type	Default	Reset Event
31:4	Reserved	RES	-	-
3	HOLD_OUT_ENABLE 1=HOLD SPI Output Port is driven 0=HOLD SPI Output Port is not driven	R/W	0h	RESET
2	HOLD_OUT_VALUE This bit sets the value on the HOLD SPI Output Port if it is driven. 1=HOLD is driven to 1 0=HOLD is driven to 0	R/W	0h	RESET
1	WRITE_PROTECT_OUT_ENABLE 1=WRITE PROTECT SPI Output Port is driven 0=WRITE PROTECT SPI Output Port is not driven	R/W	0h	RESET
0	WRITE_PROTECT_OUT_VALUE This bit sets the value on the WRITE PROTECT SPI Output Port if it is driven. 1=WRITE PROTECT is driven to 1 0=WRITE PROTECT is driven to 0	R/W	0h	RESET

38.12.5 QMSPI STATUS REGISTER

Offset	10h			
Bits	Description	Type	Default	Reset Event
31:28	Reserved	RES	-	-

MEC1725

Offset	10h			
Bits	Description	Type	Default	Reset Event
27:24	CURRENT_DESCRIPTION_BUFFER This field shows the Description Buffer currently active. This field has no meaning if Description Buffers are not enabled.	R	0h	RESET
23:17	Reserved	RES	-	-
16	TRANSFER_ACTIVE 1=A transfer is currently executing 0=No transfer currently in progress	R	0h	RESET
15	RECEIVE_BUFFER_STALL 1=The SPI interface had been stalled due to a flow issue (an attempt by the interface to write to a full Receive Buffer) 0=No stalls occurred	R/WC	0h	RESET
14	RECEIVE_BUFFER_REQUEST This status is asserted if the Receive Buffer reaches a high water mark established by the RECEIVE_BUFFER_TRIGGER field. 1=RECEIVE_BUFFER_COUNT is greater than or equal to RECEIVE_BUFFER_TRIGGER 0=RECEIVE_BUFFER_COUNT is less than RECEIVE_BUFFER_TRIGGER	R/WC	0h	RESET
13	RECEIVE_BUFFER_EMPTY 1=The Receive Buffer is empty 0=The Receive Buffer is not empty	R	1h	RESET
12	RECEIVE_BUFFER_FULL 1=The Receive Buffer is full 0=The Receive Buffer is not full	R	0h	RESET
11	TRANSMIT_BUFFER_STALL 1=The SPI interface had been stalled due to a flow issue (an attempt by the interface to read from an empty Transmit Buffer) 0=No stalls occurred	R/WC	0h	RESET
10	TRANSMIT_BUFFER_REQUEST This status is asserted if the Transmit Buffer reaches a high water mark established by the TRANSMIT_BUFFER_TRIGGER field. 1=TRANSMIT_BUFFER_COUNT is less than or equal to TRANSMIT_BUFFER_TRIGGER 0=TRANSMIT_BUFFER_COUNT is greater than TRANSMIT_BUFFER_TRIGGER	R/WC	0h	RESET
9	TRANSMIT_BUFFER_EMPTY 1=The Transmit Buffer is empty 0=The Transmit Buffer is not empty	R	1h	RESET
8	TRANSMIT_BUFFER_FULL 1=The Transmit Buffer is full 0=The Transmit Buffer is not full	R	0h	RESET

Offset	10h			
Bits	Description	Type	Default	Reset Event
7	Reserved	RES	-	-
6	LOCAL_DMA_TX_ERROR 1=Error during transfer 0= No Error	R	1h	RESET
5	LOCAL_DMA_RX_ERROR 1=Error during transfer 0=No Error	R	0h	RESET
4	PROGRAMMING_ERROR This bit if a programming error is detected. Programming errors are listed in Section 38.11.4, "Error Conditions" . 1=Programming Error detected 0=No programming error detected	R/WC	0h	RESET
3	RECEIVE_BUFFER_ERROR 1=Underflow error occurred (attempt to read from an empty Receive Buffer) 0=No underflow occurred	R/WC	0h	RESET
2	TRANSMIT_BUFFER_ERROR 1=Overflow error occurred (attempt to write to a full Transmit Buffer) 0=No overflow occurred	R/WC	0h	RESET
1	DMA_COMPLETE This field has no meaning if DMA is not enabled. This bit will be set to '1' when the DMA controller asserts the DONE signal to the SPI controller. This occurs either when the SPI controller has closed the DMA transfer, or the DMA channel has completed its count. If both Transmit and Receive DMA transfers are active, then this bit will only assert after both have completed. If CLOSE_TRANSFER_ENABLE is enabled, DMA_COMPLETE and TRANSFER_COMPLETE will be asserted simultaneously. This status is not inhibited by the description buffers, so it can fire on all valid description buffers while operating in that mode. 1=DMA completed 0=DMA not completed	R/WC	0h	RESET

MEC1725

Offset	10h			
Bits	Description	Type	Default	Reset Event
0	<p>TRANSFER_COMPLETE</p> <p>In Manual Mode (neither DMA nor Description Buffers are enabled), this bit will be set to '1' when the transfer matches TRANSFER_LENGTH.</p> <p>If DMA Mode is enabled, this bit will be set to '1' when DMA_COMPLETE is set to '1'.</p> <p>In Description Buffer Mode, this bit will be set to '1' only when the Last Buffer completes its transfer.</p> <p>In all cases, this bit will be set to '1' if the STOP bit is set to '1' and the controller has completed the current 8 bits being copied.</p> <p>1=Transfer completed 0=Transfer not complete</p>	R/WC	0h	RESET

38.12.6 QMSPI BUFFER COUNT STATUS REGISTER

Offset	14h			
Bits	Description	Type	Default	Reset Event
31:16	<p>RECEIVE_BUFFER_COUNT</p> <p>This is a count of the number of bytes currently valid in the Receive Buffer.</p>	R	0h	RESET
15:0	<p>TRANSMIT_BUFFER_COUNT</p> <p>This is a count of the number of bytes currently valid in the Transmit Buffer.</p>	R	0h	RESET

38.12.7 QMSPI INTERRUPT ENABLE REGISTER

Offset	18h			
Bits	Description	Type	Default	Reset Event
31:15	Reserved	RES	-	-
14	<p>RECEIVE_BUFFER_REQUEST_ENABLE</p> <p>1=Enable an interrupt if RECEIVE_BUFFER_REQUEST is asserted 0=Disable the interrupt</p>	R/W	0h	RESET
13	<p>RECEIVE_BUFFER_EMPTY_ENABLE</p> <p>1=Enable an interrupt if RECEIVE_BUFFER_EMPTY is asserted 0=Disable the interrupt</p>	R/W	1h	RESET
12	<p>RECEIVE_BUFFER_FULL_ENABLE</p> <p>1=Enable an interrupt if RECEIVE_BUFFER_FULL is asserted 0=Disable the interrupt</p>	R/W	0h	RESET
11	Reserved	RES	-	-

Offset	18h			
Bits	Description	Type	Default	Reset Event
10	TRANSMIT_BUFFER_REQUEST_ENABLE 1=Enable an interrupt if TRANSMIT_BUFFER_REQUEST is asserted 0=Disable the interrupt	R/W	0h	RESET
9	TRANSMIT_BUFFER_EMPTY_ENABLE 1=Enable an interrupt if TRANSMIT_BUFFER_EMPTY is asserted 0=Disable the interrupt	R/W	0h	RESET
8	TRANSMIT_BUFFER_FULL_ENABLE 1=Enable an interrupt if TRANSMIT_BUFFER_FULL is asserted 0=Disable the interrupt	R/W	0h	RESET
7	Reserved	RES	-	-
6	LOCAL_DMA_TX_ERR_ENABLE 1=Enable an interrupt if LOCAL_DMA_TX_ERROR is asserted 0=Disable the interrupt	R/W	0h	RESET
5	LOCAL_DMA_RX_ERR_ENABLE 1=Enable an interrupt if LOCAL_DMA_RX_ERROR is asserted 0=Disable the interrupt	R/W	0h	RESET
4	PROGRAMMING_ERROR_ENABLE 1=Enable an interrupt if PROGRAMMING_ERROR is asserted 0=Disable the interrupt	R/W	0h	RESET
3	RECEIVE_BUFFER_ERROR_ENABLE 1=Enable an interrupt if RECEIVE_BUFFER_ERROR is asserted 0=Disable the interrupt	R/W	0h	RESET
2	TRANSMIT_BUFFER_ERROR_ENABLE 1=Enable an interrupt if TRANSMIT_BUFFER_ERROR is asserted 0=Disable the interrupt	R/W	0h	RESET
1	DMA_COMPLETE_ENABLE 1=Enable an interrupt if DMA_COMPLETE is asserted 0=Disable the interrupt	R/W	0h	RESET
0	TRANSFER_COMPLETE_ENABLE 1=Enable an interrupt if TRANSFER_COMPLETE is asserted 0=Disable the interrupt	R/W	0h	RESET

MEC1725

38.12.8 QMSPI BUFFER COUNT TRIGGER REGISTER

Offset	1Ch			
Bits	Description	Type	Default	Reset Event
31:16	RECEIVE_BUFFER_TRIGGER An interrupt is triggered if the RECEIVE_BUFFER_COUNT field is greater than or equal to this value. A value of '0' disables the interrupt.	R/W	0h	RESET
15:0	TRANSMIT_BUFFER_TRIGGER An interrupt is triggered if the TRANSMIT_BUFFER_COUNT field is less than or equal to this value. A value of '0' disables the interrupt.	R/W	0h	RESET

38.12.9 QMSPI TRANSMIT BUFFER REGISTER

Offset	20h			
Bits	Description	Type	Default	Reset Event
31:0	TRANSMIT_BUFFER Writes to this register store data to be transmitted from the SPI Master to the external SPI Slave. Writes to this block will be written to the Transmit FIFO. A 1 Byte write fills 1 byte of the FIFO. A Word write fills 2 Bytes and a Doubleword write fills 4 bytes. The data must always be aligned to the bottom most byte (so 1 byte write is on bits [7:0] and Word write is on [15:0]). An overflow condition, TRANSMIT_BUFFER_ERROR will happen, if a write to a full FIFO occurs. Write accesses to this register increment the TRANSMIT_BUFFER_COUNT field.	W	0h	RESET

38.12.10 QMSPI RECEIVE BUFFER REGISTER

Offset	24h			
Bits	Description	Type	Default	Reset Event
31:0	RECEIVE_BUFFER Buffer that stores data from the external SPI Slave device to the SPI Master (this block), which is received over MISO or IO. Reads from this register will empty the Rx FIFO. A 1 Byte read will have valid data on bits [7:0] and a Word read will have data on bits [15:0]. It is possible to request more data than the FIFO has (underflow condition), but this will cause an error (RECEIVE_BUFFER_ERROR). Read accesses to this register decrement the RECEIVE_BUFFER_COUNT field.	R	0h	RESET

38.12.11 QMSPI CHIP SELECT TIMING REGISTER

Offset	28h			
Bits	Description	Type	Default	Reset Event
31:24	<p>DELAY_CS_OFF_TO_CS_ON</p> <p>This selects the number of system clock cycles between CS deassertion to CS assertion. This is the minimum pulse width of CS deassertion.</p> <p>Note: this field delays the start of the next transaction, it does not delay the status of the current transaction.</p>	R/W	06h	RESET
23:20	Reserved	RES	0h	RESET
19:16	<p>DELAY_LAST_DATA_HOLD</p> <p>This selects the number of system clock cycles between CS deassertion to the data ports for WP and HOLD switching from input to output. This is only used if the WP/HOLD functions are in use and only on IO2/WP and IO3/HOLD pins.</p>	R/W	6h	RESET
15:12	Reserved	RES	0h	RESET
11:8	<p>DELAY_CLK_STOP_TO_CS_OFF</p> <p>This selects the number of system clock cycles between the last clock edge and the deassertion of CS.</p>	R/W	4h	RESET
7:4	Reserved	RES	0h	RESET
3:0	<p>DELAY_CS_ON_TO_CLOCK_START</p> <p>This selects the number of system clock cycles between CS assertion to the start of the SPI Clock. An additional ½ SPI Clock delay is inherently added to allow pre-set-up of the data ports.</p>	R/W	6h	RESET

38.12.12 QMSPI DESCRIPTION BUFFER 0 REGISTER

Offset	30h			
Bits	Description	Type	Default	Reset Event
31:17	<p>TRANSFER_LENGTH</p> <p>The length of the SPI transfer. The count is in bytes or bits, depending on the value of TRANSFER_LENGTH_BITS. A value of '0' means an infinite length transfer.</p>	R/W	0h	RESET
16	<p>DESCRIPTION_BUFFER_LAST</p> <p>If this bit is '1' then this is the last Description Buffer in the chain. When the transfer described by this buffer completes the TRANSFER_COMPLETE status will be set to '1'. If this bit is '0', then this is not the last buffer in use. When the transfer completes the next buffer will be activated, and no additional status will be asserted.</p>	R/W	0h	RESET
15:12	<p>DESCRIPTION_BUFFER_NEXT_POINTER</p> <p>This defines the next buffer to be used if Description Buffers are enabled and this is not the last buffer. This can point to the current buffer, creating an infinite loop.</p>	R/W	0h	RESET

MEC1725

Offset	30h			
Bits	Description	Type	Default	Reset Event
11:10	<p>TRANSFER_UNITS</p> <p>3=TRANSFER_LENGTH defined in units of 16-byte segments 2=TRANSFER_LENGTH defined in units of 4-byte segments 1=TRANSFER_LENGTH defined in units of bytes 0=TRANSFER_LENGTH defined in units of bits</p>	R/W	0h	RESET
9	<p>CLOSE_TRANFSEER_ENABLE</p> <p>This selects what action is taken at the end of a transfer. This bit must be set only on the Last Buffer.</p> <p>1=The transfer is terminated. The Chip Select de-asserts, the SPI interface returns to IDLE and the DMA interface completes the transfer. 0=The transfer is not closed. Chip Select remains asserted and the DMA interface and the SPI interface remain active</p>	R/W	0h	RESET
8:7	<p>RX_DMA_ENABLE</p> <p>This bit enables DMA support for Receive Transfer. If enabled, DMA will be requested to empty the FIFO until either the interface reaches TRANSFER_LENGTH or the DMA sends a termination request. The size defined here must match DMA programmed access size.</p> <p>1= DMA is enabled.and set to 1 Byte 2= DMA is enabled and set to 2 Bytes 3= DMA is enabled and set to 4 Bytes 0= DMA is disabled. All data in the Receive Buffer must be emptied by firmware</p> <p>Note: When the local DMA is in use: RX_DMA_ENABLE selects what channel of the local Rx DMA is selected. If 0, DMA is disabled. If 1 to 3 local Rx DMA channel 1 to 3 is selected.</p>	R/W	0h	RESET
6	<p>RX_TRANSFER_ENABLE</p> <p>This bit enables the receive function of the SPI interface.</p> <p>1=Receive is enabled. Data received from the SPI Slave is stored in the Receive Buffer 0=Receive is disabled</p>	R/W	0h	RESET
5:4	<p>TX_DMA_ENABLE</p> <p>This bit enables DMA support for Transmit Transfer. If enabled, DMA will be requested to fill the FIFO until either the interface reaches TRANSFER_LENGTH or the DMA sends a termination request. The size defined here must match DMA programmed access size.</p> <p>1= DMA is enabled.and set to 1 Byte 2= DMA is enabled and set to 2 Bytes 3= DMA is enabled and set to 4 Bytes 0= DMA is disabled. All data in the Transmit Buffer must be emptied by firmware</p> <p>Note: When the local DMA is in use: TX_DMA_ENABLE selects what channel of the local Tx DMA is selected. If 0, DMA is disabled. If 1 to 3 local Tx DMA channel 1 to 3 is selected.</p>	R/W	0h	RESET

Offset	30h			
Bits	Description	Type	Default	Reset Event
3:2	TX_TRANSFER_ENABLE This field bit selects the transmit function of the SPI interface. 3=Transmit Enabled in 1 Mode. The MOSI or IO Bus will send out only 1's. The Transmit Buffer will not be used 2=Transmit Enabled in 0 Mode. The MOSI or IO Bus will send out only 0's. The Transmit Buffer will not be used. 1=Transmit Enabled. Data will be fetched from the Transmit Buffer and sent out on the MOSI or IO Bus. 0=Transmit is Disabled. No data is sent. This will cause the MOSI be to be undriven, or the IO bus to be undriven if Receive is also disabled.	R/W	0h	RESET
1:0	INTERFACE_MODE This field sets the transmission mode. If this field is set for Dual Mode or Quad Mode then either TX_TRANSFER_ENABLE or RX_TRANSFER_ENABLE must be 0. 3=Reserved 2=Quad Mode 1=Dual Mode 0=Single/Duplex Mode	R/W	0h	RESET

38.12.13 QMSPI DESCRIPTION BUFFER 1 REGISTER

The format for this register is the same as the format of the [QMSPI Description Buffer 0 Register](#).

38.12.14 QMSPI DESCRIPTION BUFFER 2 REGISTER

The format for this register is the same as the format of the [QMSPI Description Buffer 0 Register](#).

38.12.15 QMSPI DESCRIPTION BUFFER 3 REGISTER

The format for this register is the same as the format of the [QMSPI Description Buffer 0 Register](#).

38.12.16 QMSPI DESCRIPTION BUFFER 4 REGISTER

The format for this register is the same as the format of the [QMSPI Description Buffer 0 Register](#).

38.12.17 QMSPI DESCRIPTION BUFFER 5 REGISTER

The format for this register is the same as the format of the [QMSPI Description Buffer 0 Register](#).

38.12.18 QMSPI DESCRIPTION BUFFER 6 REGISTER

The format for this register is the same as the format of the [QMSPI Description Buffer 0 Register](#).

38.12.19 QMSPI DESCRIPTION BUFFER 7 REGISTER

The format for this register is the same as the format of the [QMSPI Description Buffer 0 Register](#).

38.12.20 QMSPI DESCRIPTION BUFFER 8 REGISTER

The format for this register is the same as the format of the [QMSPI Description Buffer 0 Register](#).

38.12.21 QMSPI DESCRIPTION BUFFER 9 REGISTER

The format for this register is the same as the format of the [QMSPI Description Buffer 0 Register](#).

38.12.22 QMSPI DESCRIPTION BUFFER 10 REGISTER

The format for this register is the same as the format of the [QMSPI Description Buffer 0 Register](#).

MEC1725

38.12.23 QMSPI DESCRIPTION BUFFER 11 REGISTER

The format for this register is the same as the format of the [QMSPI Description Buffer 0 Register](#).

38.12.24 QMSPI DESCRIPTION BUFFER 12 REGISTER

The format for this register is the same as the format of the [QMSPI Description Buffer 0 Register](#).

38.12.25 QMSPI DESCRIPTION BUFFER 13 REGISTER

The format for this register is the same as the format of the [QMSPI Description Buffer 0 Register](#).

38.12.26 QMSPI DESCRIPTION BUFFER 14 REGISTER

The format for this register is the same as the format of the [QMSPI Description Buffer 0 Register](#).

38.12.27 QMSPI DESCRIPTION BUFFER 15 REGISTER

The format for this register is the same as the format of the [QMSPI Description Buffer 0 Register](#).

38.12.28 QMSPI MODE ALTERNATE1 REGISTER

Offset	C0h			
Bits	Description	Type	Default	Reset Event
31:16	Chip Select 1 Alternate Clock Divide The SPI clock divide in number of system clocks when CS1 is in use and CS1 Alt Mode Enable is set.	R/W	0h	RESET
15:1	Reserved	RES	-	-
0	Chip Select 1 Alternate Mode Enable Enable the CS1 Clock Divide to be active if CS1 is the interface in use.	R/W	0h	RESET

38.12.29 QMSPI TAPS ADJUSTMENT REGISTER

Offset	D4h			
Bits	Description	Type	Default	Reset Event
31:16	Reserved	RES	-	-
15:8	Select Control Tap Adjustment This is a signed value used to come up with the final value for the delay. This is used to adjust the auto-H/W trim if needed.	R/W	0h	RESET
7:0	Select SCK Tap Adjustment This is a signed value used to come up with the final value for the delay. This is used to adjust the auto-H/W trim if needed.	R/W	0h	RESET

38.12.30 QMSPI DESCRIPTOR LOCAL DMA RX ENABLE REGISTER

Offset	100h			
Bits	Description	Type	Default	Reset Event
31:16	Reserved	RES	-	-
15:0	Local DMA Descriptor Rx Enable This enables the Local DMA usage (instead of the Central DMA) when the Descriptor Buffer register enables the DMA. Bit 0 is associated with Description Buffer[0] while bit 15 is associated with Description Buffer [15].	R/W	0h	RESET

38.12.31 QMSPI DESCRIPTOR LOCAL DMA TX ENABLE REGISTER

Offset	104h			
Bits	Description	Type	Default	Reset Event
31:16	Reserved	RES	-	-
15:0	Local DMA Descriptor Tx Enable This enables the Local DMA usage (instead of the Central DMA) when the Descriptor Buffer register enables the DMA. Bit 0 is associated with Description Buffer[0] while bit 15 is associated with Description Buffer [15].	R/W	0h	RESET

38.12.32 QMSPI LOCAL DMA RX CONTROL CHANNEL 0 REGISTER

Offset	110h			
Bits	Description	Type	Default	Reset Event
31:7	Reserved	RES	-	-
6	Local DMA Rx Increment Address Enable When set, the DMA Channel's Start Address will increment on every access. If not set the address will not increment; so it can be targeted at a FIFO style memory. 0=On Access: Start Address does not increment. 1=On Access: Start Address increments.	R/W	0h	RESET
5:4	Local DMA Rx Access Size Selects the AHB Access Size. 0=1 Byte 1=2 Bytes 2=4 Bytes	R/W	0h	RESET

MEC1725

Offset	110h			
Bits	Description	Type	Default	Reset Event
3	<p>Local DMA Rx Override Length</p> <p>This will override the length field to the QMSPI protocol FSM with the length programmed into the Local DMA.</p> <p>Do not have both Tx and Rx Local DMA's enabled with different lengths. This is a mis-programming case and will flag an error interrupt and abort the transfer.</p> <p>0=Normal Length is used. 1=Length of transfer uses the DMA length rather than the standard control register length.</p>	R/W	0h	RESET
2	<p>Local DMA Rx Restart Address Enable</p> <p>When set, the DMA Channel's Start Address will reset to its initial value upon completion. This facilitates DMA Channel re-use without reprogramming. If this is not set, then the Start Address will be the last address accessed + transfer size upon completion.</p> <p>0=On Completion: Start Address is last address accessed + transfer size. 1=On Completion: Start Address is reset to the initially programmed Start Address.</p>	R/W	0h	RESET
1	<p>Local DMA Rx Restart Enable</p> <p>This sets the DMA Channel to re-enable itself after a completion so the next DMA transfer can occur without requiring manual re-programming of the DMA Channel.</p> <p>0=On Completion: DMA is disabled and needs to be restarted. 1=On Completion: DMA is re-enabled.</p>	R/W	0h	RESET
0	<p>Local DMA Rx Channel Enable</p> <p>This states that the DMA is programmed and ready to run. While this is cleared the QMSPI will be stalled, waiting for the DMA to be transferring, once the local FIFO is full.</p> <p>This is cleared by H/W once a transfer is completed. It can be re-set by H/W if Local DMA Restart is enabled.</p> <p>0=The Local DMA Channel will not run. 1=The Local DMA Channel will run once the transfer requests this to function.</p>	R/W	0h	RESET

38.12.33 QMSPI LOCAL DMA RX START ADDRESS CHANNEL 0 REGISTER

Offset	114h			
Bits	Description	Type	Default	Reset Event
31:0	<p>Local DMA Start Address</p> <p>This enables the Local DMA usage (instead of the Central DMA) when the Descriptor Buffer register enables the DMA.</p> <p>Bit 0 is associated with Description Buffer[0] while bit 15 is associated with Description Buffer [15].</p>	R/W	0h	RESET

38.12.34 QMSPI LOCAL DMA RX LENGTH CHANNEL 0 REGISTER

Offset	118h			
Bits	Description	Type	Default	Reset Event
31:0	<p>Local DMA Length Address</p> <p>This is the maximum Length of the transfer in Bytes that the DMA Channel will allow access to. Once this length is reached the DMA Channel will terminate any further accesses, like the Central DMA does. This length can be used as a Byte Length to the QMSPI FSM's in the override mode.</p>	R/W	0h	RESET

38.12.35 QMSPI LOCAL DMA RX CONTROL CHANNEL 1 REGISTER

The format for this register is the same as the format of the [QMSPI Local DMA Rx Control Channel 0 Register](#).

38.12.36 QMSPI LOCAL DMA RX START ADDRESS CHANNEL 1 REGISTER

The format for this register is the same as the format of the [QMSPI Local DMA Rx Start Address Channel 0 Register](#).

38.12.37 QMSPI LOCAL DMA RX LENGTH CHANNEL 1 REGISTER

The format for this register is the same as the format of the [QMSPI Local DMA Rx Length Channel 0 Register](#).

38.12.38 QMSPI LOCAL DMA RX CONTROL CHANNEL 2 REGISTER

The format for this register is the same as the format of the [QMSPI Local DMA Rx Control Channel 0 Register](#).

38.12.39 QMSPI LOCAL DMA RX START ADDRESS CHANNEL 2 REGISTER

The format for this register is the same as the format of the [QMSPI Local DMA Rx Start Address Channel 0 Register](#).

38.12.40 QMSPI LOCAL DMA RX LENGTH CHANNEL 2 REGISTER

The format for this register is the same as the format of the [QMSPI Local DMA Rx Length Channel 0 Register](#).

38.12.41 QMSPI LOCAL DMA TX CONTROL CHANNEL 0 REGISTER

Offset	140h			
Bits	Description	Type	Default	Reset Event
31:7	Reserved	RES	-	-
6	<p>Local DMA Tx Increment Address Enable</p> <p>When set, the DMA Channel's Start Address will increment on every access. If not set the address will not increment; so it can be targeted at a FIFO style memory.</p> <p>0=On Access: Start Address does not increment. 1=On Access: Start Address increments.</p>	R/W	0h	RESET
5:4	<p>Local DMA Tx Access Size</p> <p>Selects the AHB Access Size.</p> <p>0=1 Byte 1=2 Bytes 2=4 Bytes</p>	R/W	0h	RESET

MEC1725

Offset	140h			
Bits	Description	Type	Default	Reset Event
3	<p>Local DMA Tx Override Length</p> <p>This will override the length field to the QMSPI protocol FSM with the length programmed into the Local DMA.</p> <p>Do not have both Tx and Rx Local DMA's enabled with different lengths. This is a mis-programming case and will flag an error interrupt and abort the transfer.</p> <p>0=Normal Length is used. 1=Length of transfer uses the DMA length rather than the standard control register length.</p>	R/W	0h	RESET
2	<p>Local DMA Tx Restart Address Enable</p> <p>When set, the DMA Channel's Start Address will reset to its initial value upon completion. This facilitates DMA Channel re-use without reprogramming. If this is not set, then the Start Address will be the last address accessed + transfer size upon completion.</p> <p>0=On Completion: Start Address is last address accessed + transfer size. 1=On Completion: Start Address is reset to the initially programmed Start Address.</p>	R/W	0h	RESET
1	<p>Local DMA Tx Restart Enable</p> <p>This sets the DMA Channel to re-enable itself after a completion so the next DMA transfer can occur without requiring manual re-programming of the DMA Channel.</p> <p>0=On Completion: DMA is disabled and needs to be restarted. 1=On Completion: DMA is re-enabled.</p>	R/W	0h	RESET
0	<p>Local DMA Tx Channel Enable</p> <p>This states that the DMA is programmed and ready to run. While this is cleared the QMSPI will be stalled, waiting for the DMA to being transferring, once the local FIFO is full.</p> <p>This is cleared by H/W once a transfer is completed. It can be re-set by H/W if Local DMA Restart is enabled.</p> <p>0=The Local DMA Channel will not run. 1=The Local DMA Channel will run once the transfer requests this to function.</p>	R/W	0h	RESET

38.12.42 QMSPI LOCAL DMA TX START ADDRESS CHANNEL 0 REGISTER

Offset	144h			
Bits	Description	Type	Default	Reset Event
31:0	<p>Local DMA TX Start Address</p> <p>This enables the Local DMA usage (instead of the Central DMA) when the Descriptor Buffer register enables the DMA.</p> <p>Bit 0 is associated with Description Buffer[0] while bit 15 is associated with Description Buffer [15].</p>	R/W	0h	RESET

38.12.43 QMSPI LOCAL DMA TX LENGTH CHANNEL 0 REGISTER

Offset	148h			
Bits	Description	Type	Default	Reset Event
31:0	<p>Local DMA Tx Length Address</p> <p>This is the maximum Length of the transfer in Bytes that the DMA Channel will allow access to. Once this length is reached the DMA Channel will terminate any further accesses, like the Central DMA does. This length can be used as a Byte Length to the QMSPI FSM's in the override mode.</p>	R/W	0h	RESET

38.12.44 QMSPI LOCAL DMA TX CONTROL CHANNEL 1 REGISTER

The format for this register is the same as the format of the [QMSPI Local DMA Tx Control Channel 0 Register](#).

38.12.45 QMSPI LOCAL DMA TX START ADDRESS CHANNEL 1 REGISTER

The format for this register is the same as the format of the [QMSPI Local DMA Tx Start Address Channel 0 Register](#).

38.12.46 QMSPI LOCAL DMA TX LENGTH CHANNEL 1 REGISTER

The format for this register is the same as the format of the [QMSPI Local DMA Tx Length Channel 0 Register](#).

38.12.47 QMSPI LOCAL DMA TX CONTROL CHANNEL 2 REGISTER

The format for this register is the same as the format of the [QMSPI Local DMA Tx Control Channel 0 Register](#).

38.12.48 QMSPI LOCAL DMA TX START ADDRESS CHANNEL 2 REGISTER

The format for this register is the same as the format of the [QMSPI Local DMA Tx Start Address Channel 0 Register](#).

38.12.49 QMSPI LOCAL DMA TX LENGTH CHANNEL 2 REGISTER

The format for this register is the same as the format of the [QMSPI Local DMA Tx Length Channel 0 Register](#).

39.0 GENERAL PURPOSE SERIAL PERIPHERAL INTERFACE

39.1 Overview

The General Purpose Serial Peripheral Interface (GP-SPI) may be used to communicate with various peripheral devices, e.g., EEPROMS, DACs, ADCs, that use a standard Serial Peripheral Interface.

.Characteristics of the GP-SPI Controller include:

- 8-bit serial data transmitted and received simultaneously over two data pins in Full Duplex mode with options to transmit and receive data serially on one data pin in Half Duplex (Bidirectional) mode.
- An internal programmable clock generator and clock polarity and phase controls allowing communication with various SPI peripherals with specific clocking requirements.
- SPI cycle completion that can be determined by status polling or interrupts.
- The ability to read data in on both SPDIN and SPDOUT in parallel. This allows this SPI Interface to support dual data rate read accesses for emerging double rate SPI flashes
- Support of back-to-back reads and writes without clock stretching, provided the host can read and write the data registers within one byte transaction time.

39.2 References

No references have been cited for this feature.

39.3 Terminology

No terminology for this block.

39.4 Interface

This block is designed to be accessed externally via the pin interface and internally via a registered host interface.

FIGURE 39-1: I/O DIAGRAM OF BLOCK

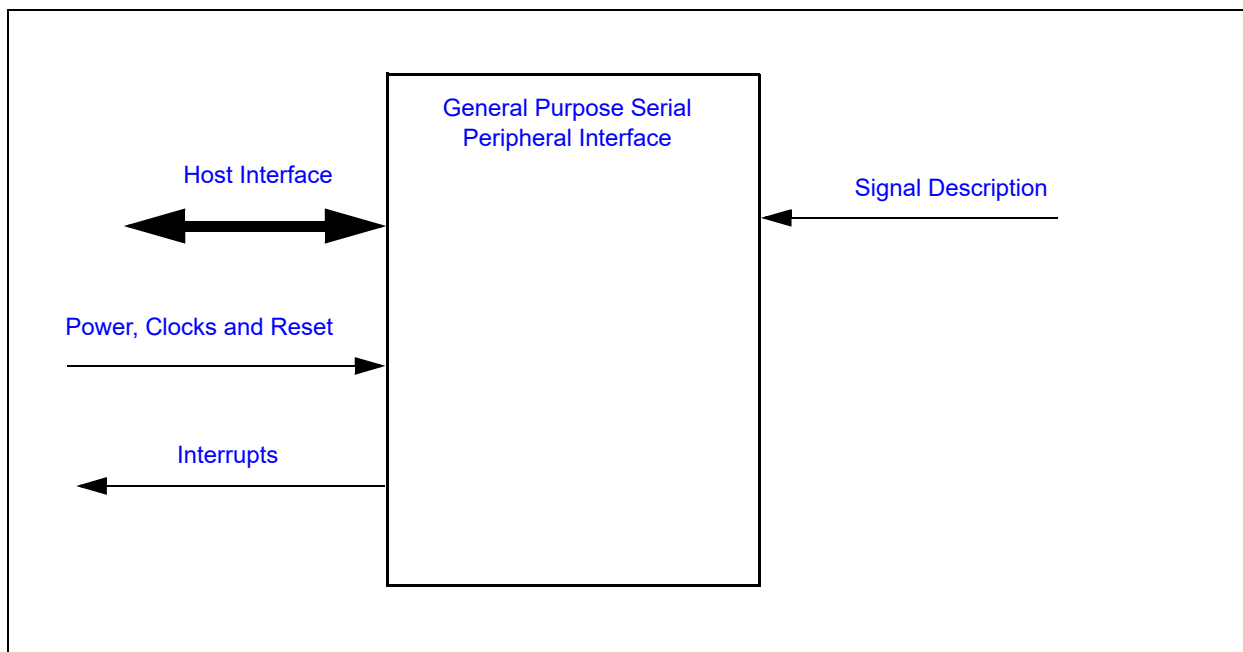

39.5 Signal Description

See the Pin Description chapter for the pins and the signal names associated with the following signals.

TABLE 39-1: EXTERNAL SIGNAL DESCRIPTION

Name	Direction	Description
SP_DIN	Input	Serial Data In pin
SP_DOUT	Input/Output	Serial Data Output pin. Switches to input when used in double-data-rate mode
SP_CLK	Output	SPI Clock output used to drive the SPCLK pin.
SP_CS#	Output	SPI chip select

TABLE 39-2: INTERNAL SIGNAL DESCRIPTION

Name	Direction	Description
SPI_TDMA_REQ	Output	DMA Request control for GP-SPI Controller Transmit Channel
SPI_RDMA_REQ	Output	DMA Request control for GP-SPI Controller Receive Channel

39.6 Host Interface

The registers defined for the General Purpose Serial Peripheral Interface are accessible by the various hosts as indicated in [Section 39.12, "EC-Only/Runtime Registers"](#).

39.7 Power, Clocks and Reset

This section defines the Power, Clock, and Reset parameters of the block.

39.7.1 POWER DOMAINS

Name	Description
VTR_CORE	The logic and registers implemented in this block are powered by this power well.

39.7.2 CLOCK INPUTS

Name	Description
48MHz	This is a clock source for the SPI clock generator.
2MHz	This is a clock source for the SPI clock generator. It is derived from the 48MHz clock domain.

39.7.3 RESETS

Name	Description
RESET_SYS	This signal resets all the registers and logic in this block to their default state.

39.8 Interrupts

This section defines the Interrupt Sources generated from this block.

TABLE 39-3: EC INTERRUPTS

Source	Description
TXBE_STS	Transmit buffer empty status (TXBE), in the SPI Status Register , sent as an interrupt request to the Interrupt Aggregator.
RXBF_STS	Receive buffer full status (RXBF), in the SPI Status Register , sent as an interrupt request to the Interrupt Aggregator.

These status bits are also connected respectively to the DMA Controller's SPI Controller TX and RX requests signals.

39.9 Low Power Modes

The GP-SPI Interface may be put into a low power state by the chip's Power, Clocks, and Reset (PCR) circuitry.

39.10 Description

The Serial Peripheral Interface (SPI) block is a master SPI block used to communicate with external SPI devices. The SPI master is responsible for generating the SPI clock and is designed to operate in Full Duplex, Half Duplex, and Dual modes of operation. The clock source may be programmed to operate at various clock speeds. The data is transmitted serially via 8-bit transmit and receive shift registers. Communication with SPI peripherals that require transactions of varying lengths can be achieved with multiple 8-bit cycles.

This block has many configuration options: The data may be transmitted and received either MSbit or LSbit first; The SPI Clock Polarity may be either active high or active low; Data may be sampled or presented on either the rising or falling edge of the clock (referred to as the transmit clock phase); and the SPI_CLK SPDOUT frequency may be programmed to a range of values as illustrated in [Table 39-4, "SPI_CLK Frequencies"](#). In addition to these many programmable options, this feature has several status bits that may be enabled to notify the host that data is being transmitted or received.

39.10.1 INITIATING AN SPI TRANSACTION

All SPI transactions are initiated by a write to the TX_DATA register. No read or write operations can be initiated until the Transmit Buffer is Empty, which is indicated by a one in the TXBE status bit.

If the transaction is a write operation, the host writes the TX_DATA register with the value to be transmitted. Writing the TX_DATA register causes the TXBE status bit to be cleared, indicating that the value has been registered. If empty, the SPI Core loads this TX_DATA value into an 8-bit transmit shift register and begins shifting the data out. Loading the value into the shift register causes the TXBE status bit to be asserted, indicating to software that the next byte can be written to the TX_DATA register.

If the transaction is a read operation, the host initiates a write to the TX_DATA register in the same manner as the write operation. Unlike the transmit command, the host must clear the RXBF status bit by reading the RX_DATA register before writing the TX_DATA register. This time, the host will be required to poll the RXBF status bit to determine when the value in the RX_DATA register is valid.

- Note 1:** If the SPI interface is configured for Half Duplex mode, the host must still write a dummy byte to receive data.
- 2:** Since RX and TX transactions are executed by the same sequence of transactions, data is always shifted into the RX_DATA register. Therefore, every write operation causes data to be latched into the RX_DATA register and the RXBF bit is set. This status bit should be cleared before initiating subsequent transactions. The host utilizing this SPI core to transmit SPI Data must discard the unwanted receive bytes.
 - 3:** The length and order of data sent to and received from a SPI peripheral varies between peripheral devices. The SPI must be properly configured and software-controlled to communicate with each device and determine whether SPIRD data is valid slave data.

The following diagrams show sample single byte and multi-byte SPI Transactions.

FIGURE 39-2: SINGLE BYTE SPI TX/RX TRANSACTIONS (FULL DUPLEX MODE)

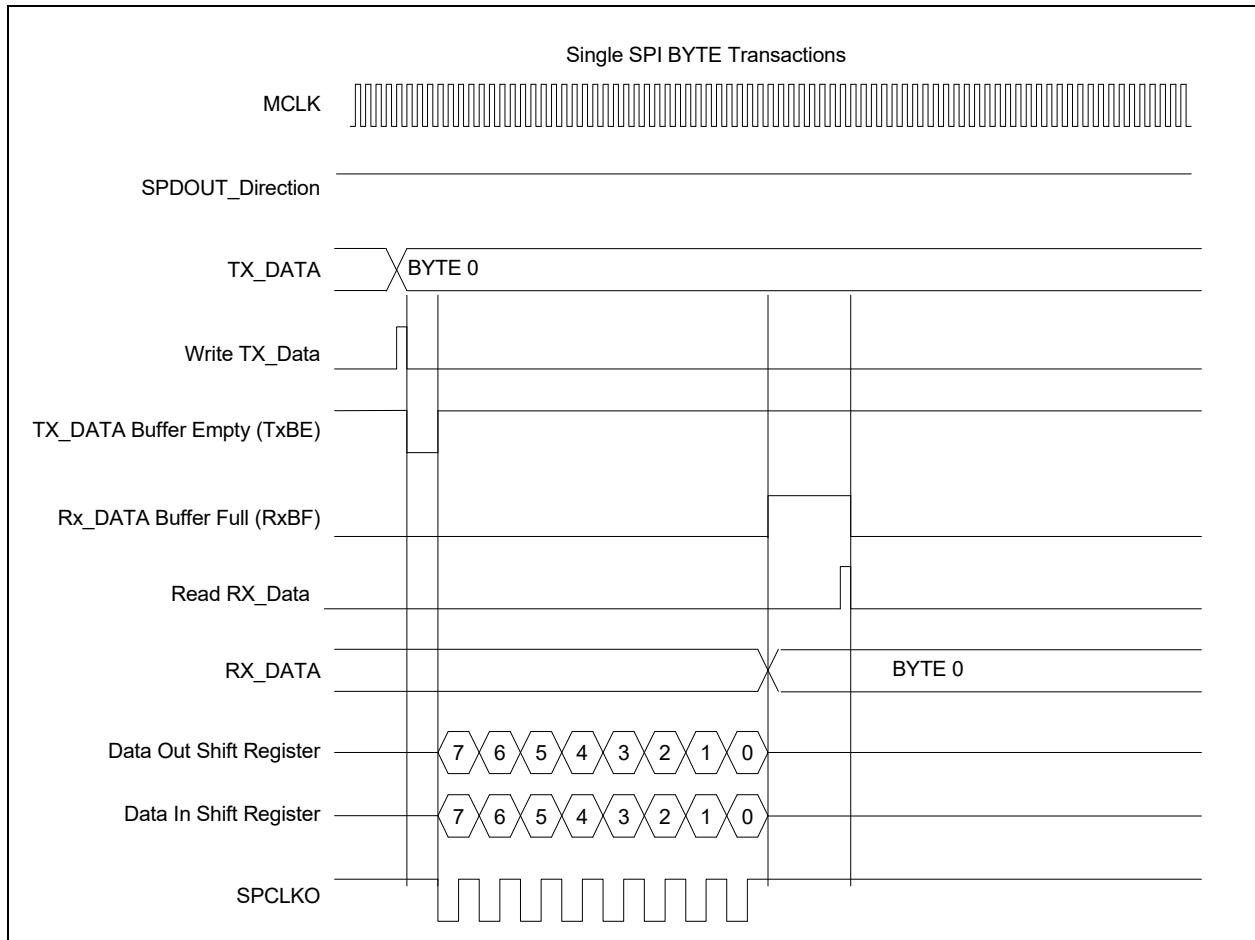
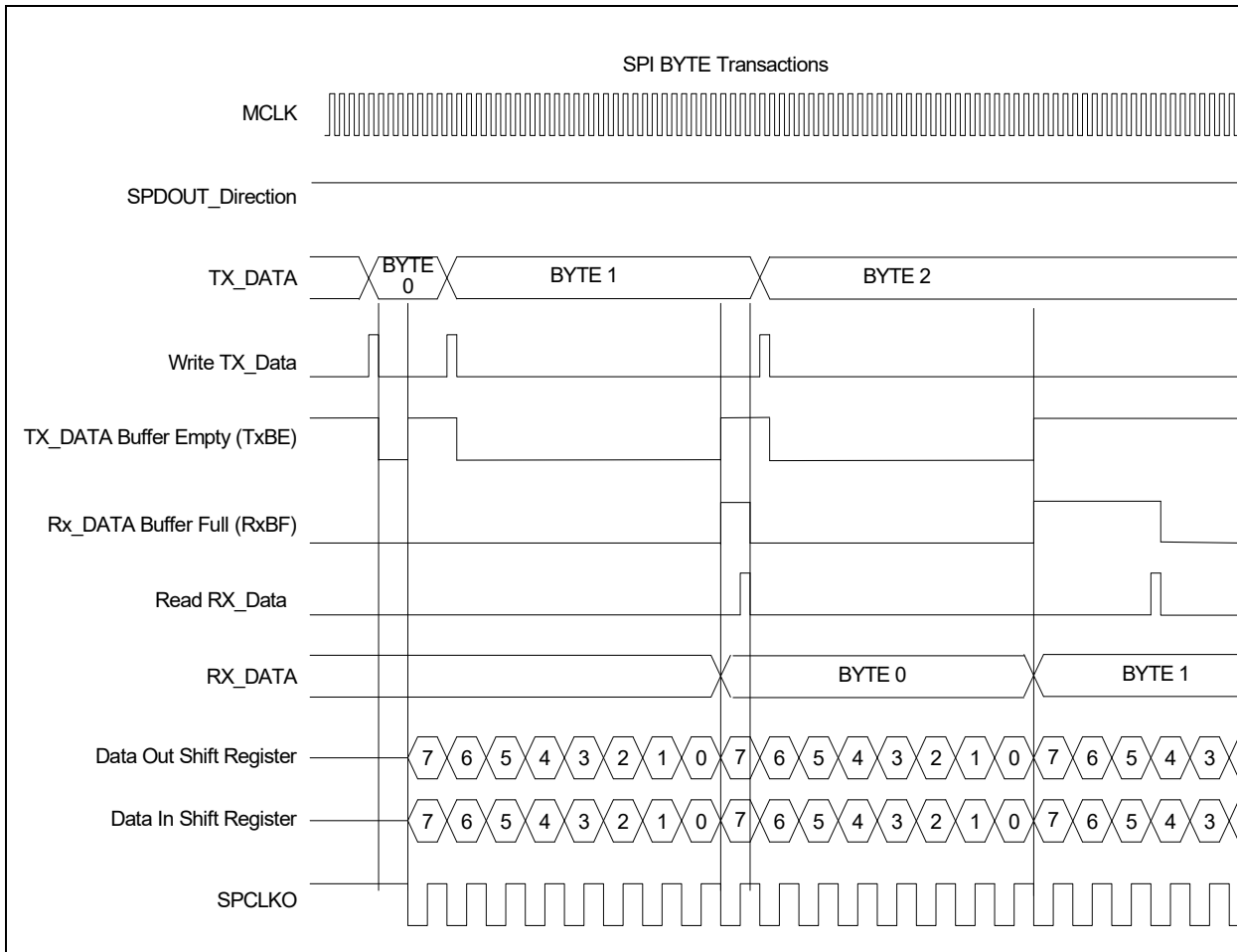

FIGURE 39-3: MULTI-BYTE SPI TX/RX TRANSACTIONS (FULL DUPLEX MODE)



The data may be configured to be transmitted MSB or LSB first. This is configured by the [LSBF](#) bit in the [SPI Control Register](#). The transmit data is shifted out on the edge as selected by the [TCLKPH](#) bit in the [SPI Clock Control Register](#). All received data can be sampled on a rising or falling [SPI_CLK](#) edge using the [RCLKPH](#) bit in the [SPI Clock Control Register](#). This clock setting must be identical to the clocking requirements of the current SPI slave.

Note: Common peripheral devices require a chip select signal to be asserted during a transaction. Chip selects for SPI devices may be controlled by MEC1725 GPIO pins.

There are three types of transactions that can be implemented for transmitting and receiving the SPI data. They are Full Duplex, Half Duplex, and Dual Mode. These modes are define in [Section 39.10.3, "Types of SPI Transactions"](#).

39.10.2 DMA MODE

Transmit and receive operations can use a DMA channel. Note that only one DMA channel may be enabled at a time. Setting up the DMA Controller involves specifying the device (Flash GP-SPI), direction (transmit/receive), and the start and end addresses of the DMA buffers in the closely couple memory. Please refer to the DMA Controller chapter for register programming information.

SPI transmit / DMA write: the GP-SPI block's transmit empty (TxBE) status signal is used as a write request to the DMA controller, which then fetches a byte from the DMA transmit buffer and writes it to the GP-SPI's SPI TX Data Register (SPITD). As content of the latter is transferred to the internal Tx shift register from which data is shifted out onto the SPI

bus bit by bit, the Tx Empty signal is again asserted, triggering the DMA fetch-and-write cycle. The process continues until the end of the DMA buffer is reached - the DMA controller stops responding to an active Tx Empty until the buffer's address registers are reprogrammed.

SPI receive / DMA read: the AUTO_READ bit in the SPI Control Register must be set. The driver first writes (dummy data) to the SPI TX Data Register (SPITD) to initiate the toggling of the SPI clock, enabling data to be shifted in. After one byte is received, the Rx Full (RxBF) status signal, used as a read request to the DMA controller, is asserted. The DMA controller then reads the received byte from the GP-SPI's SPI RX Data Register (SPIRD) and stores it in the DMA receive buffer. With AUTO_READ set, this read clears both the RxBF and TxBE. Clearing TxBE causes (dummy) data from the SPI TX Data Register (SPITD) to be transferred to the internal shift register, mimicking the effect of the aforementioned write to the SPI TX Data Register (SPITD) by the driver. SPI clock is toggled again to shift in the second read byte. This process continues until the end of the DMA buffer is reached - the DMA controller stops responding to an active Tx Empty until the buffer's address registers are reprogrammed.

39.10.3 TYPES OF SPI TRANSACTIONS

The GP-SPI controller can be configured to operate in three modes: Full Duplex, Half Duplex, and Dual Mode.

39.10.3.1 Full Duplex

In Full Duplex Mode, serial data is transmitted and received simultaneously by the SPI master over the SPDOUT and SPDIN pins. To enable Full Duplex Mode clear SPDIN Select.

When a transaction is completed in the full-duplex mode, the RX_DATA shift register always contains received data (valid or not) from the last transaction.

39.10.3.2 Half Duplex

In Half Duplex Mode, serial data is transmitted and received sequentially over a single data line (referred to as the SPDOUT pin). To enable Half Duplex Mode set SPDIN Select to 01b. The direction of the SPDOUT signal is determined by the BIOEN bit.

- To transmit data in half duplex mode set the BIOEN bit before writing the TX_DATA register.
- To receive data in half duplex mode clear the BIOEN bit before writing the TX_DATA register with a dummy byte.

Note: The Software driver must properly drive the BIOEN bit and store received data depending on the transaction format of the specific slave device.
--

39.10.3.3 Dual Mode of Operation

In Dual Mode, serial data is transmitted sequentially from the SPDOUT pin and received in by the SPI master from the SPDOUT and SPDIN pins. This essentially doubles the received data rate and is often available in SPI Flash devices. To enable Dual Mode of operation the SPI core must be configured to receive data in path on the SPDIN1 and SPDIN2 inputs via SPDIN Select. The BIOEN bit determines if the SPI core is transmitting or receiving. The setting of this bit determines the direction of the SPDOUT signal. The SPDIN Select bits are configuration bits that remain static for the duration of a dual read command. The BIOEN bit must be toggled to indicate when the SPI core is transmitting and receiving.

- To transmit data in dual mode set the BIOEN bit before writing the TX_DATA register.
- To receive data in dual mode clear the BIOEN bit before writing the TX_DATA register with a dummy byte. The even bits (0,2,4,and 6) are received on the SPDOUT pin and the odd bits (1,3,5,and 7) are received on the SPDIN pin. The hardware assembles these received bits into a single byte and loads them into the RX_DATA register accordingly.

MEC1725

The following diagram illustrates a Dual Fast Read Command that is supported by some SPI Flash devices.

FIGURE 39-4: DUAL FAST READ FLASH COMMAND

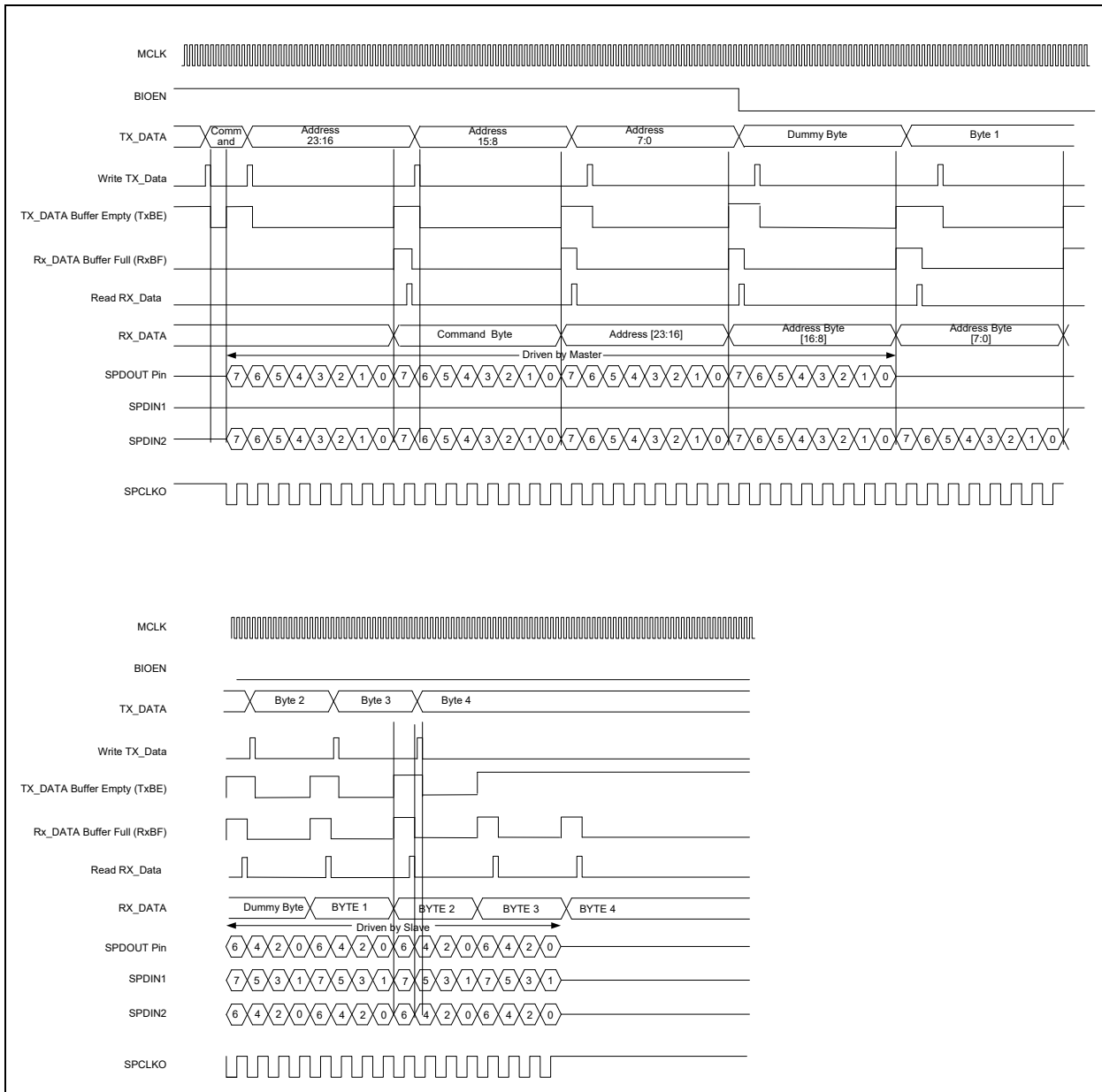

Note: When the SPI core is used for flash commands, like the Dual Read command, the host discards the bytes received during the command, address, and dummy byte portions of the transaction.

39.10.4 HOW BIOEN BIT CONTROLS DIRECTION OF SPDOUT BUFFER

When the SPI is configured for Half Duplex mode or Dual Mode the SPDOUT pin operates as a bi-directional signal. The BIOEN bit is used to determine the direction of the SPDOUT buffer when a byte is transmitted. Internally, the BIOEN bit is sampled to control the direction of the SPDOUT buffer when the TX_DATA value is loaded into the transmit shift register. The direction of the buffer is never changed while a byte is being transmitted.

Since the TX_DATA register may be written while a byte is being shifted out on the SPDOOUT pin, the BIOEN bit does not directly control the direction of the SPDOOUT buffer. An internal DIRECTION bit, which is a latched version of the BIOEN bit determines the direction of the SPDOOUT buffer. The following list summarizes when the BIOEN bit is sampled.

- The DIRECTION bit is equal to the BIOEN bit when data is not being shifted out (i.e., SPI interface is idle).
- The hardware samples the BIOEN bit when it is shifting out the last bit of a byte to determine if the buffer needs to be turned around for the next byte.
- The BIOEN bit is also sampled any time the value in the TX_DATA register is loaded into the shift register to be transmitted.

If a TAR (Turn-around time) is required between transmitting and receiving bytes on the SPDOOUT signal, software should allow all the bytes to be transmitted before changing the buffer to an input and then load the TX_DATA register to begin receiving bytes. If TAR greater than zero is required, software must wait for the transmission in one direction to complete before writing the TX_DATA register to start sending/receiving in the opposite direction. This allows the SPI block to operate the same as legacy Microchip SPI devices.

39.10.5 CONFIGURING THE SPI CLOCK GENERATOR

The SPI controller generates the SPI_CLK signal to the external SPI device. The frequency of the SPI_CLK signal is determined by one of two clock sources and the Preload value of the clock generator down counter. The clock generator toggles the SPI_CLK output every time the counter underflows, while data is being transmitted.

Note: When the SPI interface is in the idle state and data is not being transmitted, the SPI_CLK signal stops in the inactive state as determined by the configuration bits.

The clock source to the down counter is determined by Bit CLKSRC. Either the main system clock or the 2MHz clock can be used to decrement the down counter in the clock generator logic.

The SPI_CLK frequency is determined by the following formula:

$$SPI_CLK_FREQ = \left(\left(\frac{1}{2} \times REFERENCE_CLOCK \right) / PRELOAD \right)$$

The REFERENCE_CLOCK frequency is selected by CLKSRC in the SPI Clock Control Register and PRELOAD is the PRELOAD field of the SPI Clock Generator Register. The frequency can be either the 48MHz clock or a 2MHz clock. When the PRELOAD value is 0, the REFERENCE_CLOCK is always the 48MHz clock and the CLKSRC bit is ignored.

Sample SPI Clock frequencies are shown in the following table:

TABLE 39-4: SPI_CLK FREQUENCIES

Clock Source	Preload	SPI_CLK Frequency
Don't Care	0	48MHz
48MHz	1	24MHz
48MHz	2	12MHz (default)
48MHz	3	6MHz
48MHz	63	381KHz
2MHz	1	1MHz
2MHz	2	500KHz
2MHz	3	333KHz
2MHz	63	15.9KHz

39.10.6 CONFIGURING SPI MODE

In practice, there are four modes of operation that define when data should be latched. These four modes are the combinations of the SPI_CLK polarity and phase.

MEC1725

The output of the clock generator may be inverted to create an active high or active low clock pulse. This is used to determine the inactive state of the SPI_CLK signal and is used for determining the first edge for shifting the data. The polarity is selected by **CLKPOL** in the [SPI Clock Control Register](#).

The phase of the clock is selected independently for receiving data and transmitting data. The receive phase is determined by **RCLKPH** and the transmit phase is determined by **TCLKPH** in the SPI Clock Control Register.

The following table summarizes the effect of **CLKPOL**, **RCLKPH** and **TCLKPH**.

TABLE 39-5: SPI DATA AND CLOCK BEHAVIOR

CLKPOL	RCLKPH	TCLKPH	Behavior
0	0	0	Inactive state is low. First edge is rising edge. Data is sampled on the rising edge. Data is transmitted on the falling edge. Data is valid before the first rising edge.
0	0	1	Inactive state is low. First edge is rising edge. Data is sampled on the rising edge. Data is transmitted on the rising edge.
0	1	0	Inactive state is low. First edge is rising edge. Data is sampled on the falling edge. Data is transmitted on the falling edge. Data is valid before the first rising edge.
0	1	1	Inactive state is low. First edge is rising edge. Data is sampled on the falling edge. Data is transmitted on the rising edge.
1	0	0	Inactive state is high. First edge is falling edge. Data is sampled on the falling edge. Data is transmitted on the rising edge. Data is valid before the first falling edge.
1	0	1	Inactive state is high. First edge is falling edge. Data is sampled on the falling edge. Data is transmitted on the falling edge.
1	1	0	Inactive state is high. First edge is falling edge. Data is sampled on the rising edge. Data is transmitted on the rising edge. Data is valid before the first falling edge.
1	1	1	Inactive state is high. First edge is falling edge. Data is sampled on the rising edge. Data is transmitted on the falling edge.

39.11 SPI Examples

39.11.1 FULL DUPLEX MODE TRANSFER EXAMPLES

39.11.1.1 Read Only

The slave device used in this example is a MAXIM MAX1080 10 bit, 8 channel ADC:

- The SPI block is activated by setting the enable bit in SPIAR - SPI Enable Register
- The SPIMODE bit is de-asserted '0' to enable the SPI interface in Full Duplex mode.
- The CLKPOL and TCLKPH bits are de-asserted '0', and RCLKPH is asserted '1' to match the clocking requirements of the slave device.
- The LSBF bit is de-asserted '0' to indicate that the slave expects data in MSB-first order.
- Assert CS# using a GPIO pin.
- Write a valid command word (as specified by the slave device) to the SPITD - SPI TX_Data Register with TXFE asserted '1'. The SPI master automatically clears the TXFE bit indicating the byte has been put in the TX buffer. If the shift register is empty the TX_DATA byte is loaded into the shift register and the SPI master reasserts the

TXFE bit. Once the data is in the shift register the SPI master begins shifting the data value onto the SPDOUT pin and drives the SPCLK pin. Data on the SPDIN pin is also sampled on each clock.

- Once the TXFE bit is asserted the SPI Master is ready to receive its next byte. Before writing the next TX_DATA value, software must clear the RXBF status bit by reading the SPIRD - SPI RX_Data Register.
- A dummy 8 bit data value (any value) is written to the TX_DATA register. The SPI master automatically clears the TXFE bit, but does not begin shifting the dummy data value onto the SPDOUT pin. This byte will remain in the TX_DATA register until the TX shift register is empty.
- After 8 SPI_CLK pulses from the first transmit bytes:
 - The first SPI cycle is complete, RXBF bit is asserted '1', and the SPINT interrupt is asserted, if enabled. The data now contained in SPIRD - SPI RX_Data Register is invalid since the last cycle was initiated solely to transmit command data to the slave. This particular slave device drives '0' on the SPDIN pin to the master while it is accepting command data. This SPIRD data is ignored.
 - Once the first SPI cycle is completed, the SPI master takes the pending data in the TX_DATA register and loads it into the TX shift register. Loading the shift register automatically asserts the TXFE bit, begins shifting the dummy data value onto the SPDOUT pin, and drives the SPCLK pin. Data on the SPDIN pin is also sampled on each clock.
- Once the TXFE bit is asserted the SPI Master is ready to receive its next byte. Before writing the next TX_DATA value, software must clear the RXBF status bit by reading the SPIRD - SPI RX_Data Register.
- The final SPI cycle is initiated when another dummy 8 bit data value (any value) is written to the TX_DATA register. Note that this value may be another dummy value or it can be a new 8 bit command to be sent to the ADC. The new command will be transmitted while the final data from the last command is received simultaneously. This overlap allows ADC data to be read every 16 SPCLK cycles after the initial 24 clock cycle. The SPI master automatically clears the TXFE bit, but does not begin shifting the dummy data value onto the SPDOUT pin. This byte will remain in the TX_DATA register until the TX shift register is empty.
- After 8 SPI_CLK pulses, the second SPI cycle is complete:
 - The first SPI cycle is complete, RXBF bit is asserted '1', and the SPINT interrupt is asserted, if enabled. The data now contained in SPIRD - SPI RX_Data Register is the first half of a valid 16 bit ADC value. SPIRD is read and stored.
 - Once the second SPI cycle is completed, the SPI master takes the pending data in the TX_DATA register and loads it into the TX shift register. Loading the shift register automatically asserts the TXFE bit, begins shifting the data value onto the SPDOUT pin, and drives the SPCLK pin. Data on the SPDIN pin is also sampled on each clock.
- After 8 SPI_CLK pulses, the final SPI cycle is complete, TXBF is asserted '1', and the SPINT interrupt is asserted (if enabled). The data now contained in SPIRD - SPI RX_Data Register is the second half of a valid 16 bit ADC value. SPIRD is read and stored.
- If a command was overlapped with the received data in the final cycle, #CS should remain asserted and the SPI master will initiate another SPI cycle. If no new command was sent, #CS is released and the SPI is idle.

39.11.1.2 Read/Write

The slave device used in this example is a Fairchild NS25C640 FM25C640 64K Bit Serial EEPROM. The following subsections describe the read and write sequences.

Read

- The SPI block is activated by setting the enable bit in SPIAR - SPI Enable Register
- The SPIMODE bit is de-asserted '0' to enable the SPI interface in Full Duplex mode.
- The CLKPOL, TCLKPH and RCLKPH bits are de-asserted '0' to match the clocking requirements of the slave device.
- The LSBF bit is de-asserted '0' to indicate that the slave expects data in MSB-first order.
- Assert CS# low using a GPIO pin.
- Write a valid command word (as specified by the slave device) to the SPITD - SPI TX_Data Register with TXFE asserted '1'. The SPI master automatically clears the TXFE bit indicating the byte has been put in the TX buffer. If the shift register is empty the TX_DATA byte is loaded into the shift register and the SPI master reasserts the TXFE bit. Once the data is in the shift register the SPI master begins shifting the data value onto the SPDOUT pin and drives the SPI_CLK pin. Data on the SPDIN pin is also sampled on each clock.
- Once the TXFE bit is asserted the SPI Master is ready to receive its next byte. Before writing the next TX_DATA value, software must clear the RXBF status bit by reading the SPIRD - SPI RX_Data Register.

MEC1725

- Next, EEPROM address A15-A8 is written to the TX_DATA register. The SPI master automatically clears the TXFE bit, but does not begin shifting the dummy data value onto the SPDOUT pin. This byte will remain in the TX_DATA register until the TX shift register is empty.
- After 8 SPI_CLK pulses from the first transmit byte (Command Byte transmitted):
 - The first SPI cycle is complete, RXBF bit is asserted '1', and the SPINT interrupt is asserted, if enabled. The data now contained in SPIRD - SPI RX_Data Register is invalid since the last cycle was initiated solely to transmit command data to the slave. This particular slave device tri-states the SPDIN pin to the master while it is accepting command data. This SPIRD data is ignored.

USER'S NOTE: External pull-up or pull-down is required on the SPDIN pin if it is tri-stated by the slave device.

- Once the first SPI cycle is completed, the SPI master takes the pending data in the TX_DATA register (EEPROM address A15-A8) and loads it into the TX shift register. Loading the shift register automatically asserts the TXFE bit, begins shifting the dummy data value onto the SPDOUT pin, and drives the SPI_CLK pin. Data on the SPDIN pin is also sampled on each clock. Note: The particular slave device ignores address A15-A13.
- Once the TXFE bit is asserted the SPI Master is ready to receive its next byte. Before writing the next TX_DATA value, software must clear the RXBF status bit by reading the SPIRD - SPI RX_Data Register.
- Next, EEPROM address A7-A0 is written to the TX_DATA register. The SPI master automatically clears the TXFE bit, but does not begin shifting this data value onto the SPDOUT pin. This byte will remain in the TX_DATA register until the TX shift register is empty.
- After 8 SPI_CLK pulses from the second transmit byte (Address Byte (MSB) transmitted):
 - EEPROM address A15-A8 has been transmitted to the slave completing the second SPI cycle. Once again, the RXBF bit is asserted '1' and the SPINT interrupt is asserted, if enabled. The data now contained in SPIRD - SPI RX_Data Register is invalid since the last cycle was initiated solely to transmit address data to the slave.
 - Once the second SPI cycle is completed, the SPI master takes the pending data in the TX_DATA register (EEPROM address A7-A0) and loads it into the TX shift register. Loading the shift register automatically asserts the TXFE bit, begins shifting the dummy data value onto the SPDOUT pin, and drives the SPCLK pin. Data on the SPDIN pin is also sampled on each clock.
- Once the TXFE bit is asserted the SPI Master is ready to receive its next byte. Before writing the next TX_DATA value, software must clear the RXBF status bit by reading the SPIRD - SPI RX_Data Register.
- Next, a dummy byte is written to the TX_DATA register. The SPI master automatically clears the TXFE bit, but does not begin shifting this data value onto the SPDOUT pin. This byte will remain in the TX_DATA register until the TX shift register is empty.
- After 8 SPI_CLK pulses, the third SPI cycle is complete (Address Byte (LSB) transmitted):
 - EEPROM address A7-A0 has been transmitted to the slave completing the third SPI cycle. Once again, the RXBF bit is asserted '1' and the SPINT interrupt is asserted, if enabled. The data now contained in SPIRD - SPI RX_Data Register is invalid since the last cycle was initiated solely to transmit address data to the slave.
 - Once the third SPI cycle is completed, the SPI master takes the pending data in the TX_DATA register (dummy byte) and loads it into the TX shift register. Loading the shift register automatically asserts the TXFE bit, begins shifting the dummy data value onto the SPDOUT pin, and drives the SPCLK pin. Data on the SPDIN pin is also sampled on each clock.
- Once the TXFE bit is asserted the SPI Master is ready to receive its next byte. Before writing the next TX_DATA value, software must clear the RXBF status bit by reading the SPIRD - SPI RX_Data Register.
- If only one receive byte is required, the host would not write any more value to the TX_DATA register until this transaction completes. If more than one byte of data is to be received, another dummy byte would be written to the TX_DATA register (one dummy byte per receive byte is required). The SPI master automatically clears the TXFE bit when the TX_DATA register is written, but does not begin shifting this data value onto the SPDOUT pin. This byte will remain in the TX_DATA register until the TX shift register is empty.
- After 8 SPI_CLK pulses, the fourth SPI cycle is complete (First Data Byte received):
 - The dummy byte has been transmitted to the slave completing the fourth SPI cycle. Once again, the RXBF bit is asserted '1' and the SPINT interrupt is asserted, if enabled. Unlike the command and address phases, the data now contained in SPIRD - SPI RX_Data Register is the 8-bit EEPROM data since the last cycle was initiated to receive data from the slave.

- Once the fourth SPI cycle is completed, the SPI master takes the pending data in the TX_DATA register (if any) and loads it into the TX shift register. This process will be repeated until all the desired data is received.
- The host software will read and store the EEPROM data value in SPIRD - SPI RX_Data Register.
- If no more data needs to be received by the master, CS# is released and the SPI is idle. Otherwise, master continues reading the data by writing a dummy value to the TX_DATA register after every 8 SPI_CLK cycles.

Write

- The SPI block is activated by setting the enable bit in SPIAR - SPI Enable Register
- The SPIMODE bit is de-asserted '0' to enable the SPI interface in Full Duplex mode.
- The CLKPOL, TCLKPH and RCLKPH bits are de-asserted '0' to match the clocking requirements of the slave device.
- The LSBF bit is de-asserted '0' to indicate that the slave expects data in MSB-first order.
- Assert WR# high using a GPIO pin.
- Assert CS# low using a GPIO pin.
- Write a valid command word (as specified by the slave device) to the SPITD - SPI TX_Data Register with TXFE asserted '1'. The SPI master automatically clears the TXFE bit indicating the byte has been put in the TX buffer. If the shift register is empty the TX_DATA byte is loaded into the shift register and the SPI master reasserts the TXFE bit. Once the data is in the shift register the SPI master begins shifting the data value onto the SPDOUT pin and drives the SPI_CLK pin. Data on the SPDIN pin is also sampled on each clock.
- Once the TXFE bit is asserted the SPI Master is ready to receive its next byte. Before writing the next TX_DATA value, software must clear the RXBF status bit by reading the SPIRD - SPI RX_Data Register.
- Next, EEPROM address A15-A8 is written to the TX_DATA register. The SPI master automatically clears the TXFE bit, but does not begin shifting the dummy data value onto the SPDOUT pin. This byte will remain in the TX_DATA register until the TX shift register is empty.
- After 8 SPI_CLK pulses from the first transmit byte (Command Byte transmitted):
 - The first SPI cycle is complete, RXBF bit is asserted '1', and the SPINT interrupt is asserted, if enabled. The data now contained in SPIRD - SPI RX_Data Register is invalid since the last cycle was initiated solely to transmit command data to the slave. This particular slave device tri-states the SPDIN pin to the master while it is accepting command data. This SPIRD data is ignored.

USER'S NOTE: External pull-up or pull-down is required on the SPDIN pin if it is tri-stated by the slave device.

- Once the first SPI cycle is completed, the SPI master takes the pending data in the TX_DATA register (EEPROM address A15-A8) and loads it into the TX shift register. Loading the shift register automatically asserts the TXFE bit, begins shifting the dummy data value onto the SPDOUT pin, and drives the SPI_CLK pin. Data on the SPDIN pin is also sampled on each clock. Note: The particular slave device ignores address A15-A13.
- Once the TXFE bit is asserted the SPI Master is ready to receive its next byte. Before writing the next TX_DATA value, software must clear the RXBF status bit by reading the SPIRD - SPI RX_Data Register.
- Next, EEPROM address A7-A0 is written to the TX_DATA register. The SPI master automatically clears the TXFE bit, but does not begin shifting this data value onto the SPDOUT pin. This byte will remain in the TX_DATA register until the TX shift register is empty.
- After 8 SPI_CLK pulses from the second transmit byte (Address Byte (MSB) transmitted):
 - EEPROM address A15-A8 has been transmitted to the slave completing the second SPI cycle. Once again, the RXBF bit is asserted '1' and the SPINT interrupt is asserted, if enabled. The data now contained in SPIRD - SPI RX_Data Register is invalid since the last cycle was initiated solely to transmit address data to the slave.
 - Once the second SPI cycle is completed, the SPI master takes the pending data in the TX_DATA register (EEPROM address A7-A0) and loads it into the TX shift register. Loading the shift register automatically asserts the TXFE bit, begins shifting the dummy data value onto the SPDOUT pin, and drives the SPCLK pin. Data on the SPDIN pin is also sampled on each clock.
- Once the TXFE bit is asserted the SPI Master is ready to receive its next byte. Before writing the next TX_DATA value, software must clear the RXBF status bit by reading the SPIRD - SPI RX_Data Register.
- Next, a data byte (D7:D0) is written to the TX_DATA register. The SPI master automatically clears the TXFE bit, but does not begin shifting this data value onto the SPDOUT pin. This byte will remain in the TX_DATA register until the TX shift register is empty.

- After 8 SPI_CLK pulses, the third SPI cycle is complete (Address Byte (LSB) transmitted):
 - EEPROM address A7-A0 has been transmitted to the slave completing the third SPI cycle. Once again, the RXBF bit is asserted '1' and the SPINT interrupt is asserted, if enabled. The data now contained in SPIRD - SPI RX_Data Register is invalid since the last cycle was initiated solely to transmit address data to the slave.
 - Once the third SPI cycle is completed, the SPI master takes the pending data in the TX_DATA register (data byte D7:D0) and loads it into the TX shift register. Loading the shift register automatically asserts the TXFE bit, begins shifting the dummy data value onto the SPDOUT pin, and drives the SPCLK pin. Data on the SPDIN pin is also sampled on each clock.
- Once the TXFE bit is asserted the SPI Master is ready to receive its next byte. Before writing the next TX_DATA value, software must clear the RXBF status bit by reading the SPIRD - SPI RX_Data Register.
- If only one data byte is to be written, the host would not write any more values to the TX_DATA register until this transaction completes. If more than one byte of data is to be written, another data byte would be written to the TX_DATA register. The SPI master automatically clears the TXFE bit when the TX_DATA register is written, but does not begin shifting this data value onto the SPDOUT pin. This byte will remain in the TX_DATA register until the TX shift register is empty.
- After 8 SPI_CLK pulses, the fourth SPI cycle is complete (First Data Byte transmitted):
 - The data byte has been transmitted to the slave completing the fourth SPI cycle. Once again, the RXBF bit is asserted '1' and the SPINT interrupt is asserted, if enabled. Like the command and address phases, the data now contained in SPIRD - SPI RX_Data Register is invalid since the last cycle was initiated to transmit data to the slave.
 - Once the fourth SPI cycle is completed, the SPI master takes the pending data in the TX_DATA register (if any) and loads it into the TX shift register. This process will be repeated until all the desired data is transmitted.
- If no more data needs to be transmitted by the master, CS# and WR# are released and the SPI is idle.

39.11.2 HALF DUPLEX (BIDIRECTIONAL MODE) TRANSFER EXAMPLE

The slave device used in this example is a National LM74 12 bit (plus sign) temperature sensor.

- The SPI block is activated by setting the enable bit in SPIAR - SPI Enable Register
- The SPIMODE bit is asserted '1' to enable the SPI interface in Half Duplex mode.
- The CLKPOL, TCLKPH and RCLKPH bits are de-asserted '0' to match the clocking requirements of the slave device.
- The LSBF bit is de-asserted '0' to indicate that the slave expects data in MSB-first order.
- BIOEN is asserted '0' to indicate that the first data in the transaction is to be received from the slave.
- Assert CS# using a GPIO pin.

//Receive 16-bit Temperature Reading

- Write a dummy command byte (as specified by the slave device) to the SPITD - SPI TX_Data Register with TXFE asserted '1'. The SPI master automatically clears the TXFE bit indicating the byte has been put in the TX buffer. If the shift register is empty the TX_DATA byte is loaded into the shift register and the SPI master reasserts the TXFE bit. Once the data is in the shift register the SPI master begins shifting the data value onto the SPDOUT pin and drives the SPI_CLK pin. This data is lost because the output buffer is disabled. Data on the SPDIN pin is sampled on each clock.
- Once the TXFE bit is asserted the SPI Master is ready to receive its next byte. Before writing the next TX_DATA value, software must clear the RXBF status bit by reading the SPIRD - SPI RX_Data Register.
- Next, another dummy byte is written to the TX_DATA register. The SPI master automatically clears the TXFE bit, but does not begin shifting the dummy data value onto the SPDOUT pin. This byte will remain in the TX_DATA register until the TX shift register is empty.
- After 8 SPI_CLK pulses from the first receive byte
 - The first SPI cycle is complete, RXBF bit is asserted '1', and the SPINT interrupt is asserted, if enabled. The data now contained in SPIRD - SPI RX_Data Register is the first half of the 16 bit word containing the temperature data.
 - Once the first SPI cycle is completed, the SPI master takes the pending data in the TX_DATA register (dummy byte 2) and loads it into the TX shift register. Loading the shift register automatically asserts the TXFE bit, begins shifting the dummy data value onto the SPDOUT pin, and drives the SPI_CLK pin. Data on the SPDIN pin is also sampled on each clock.

- Once the TXFE bit is asserted the SPI Master is ready to receive its next byte. Before writing the next TX_DATA value, software must clear the RXBF status bit by reading the SPIRD - SPI RX_Data Register.

//Transmit next reading command

- BIOEN is asserted '1' to indicate that data will now be driven by the master.
- Next, a command byte is written to the TX_DATA register. This value is the first half of a 16 bit command to be sent to temperature sensor peripheral. The SPI master automatically clears the TXFE bit, but does not begin shifting the command data value onto the SPDOUT pin. This byte will remain in the TX_DATA register until the TX shift register is empty. This data will be transmitted because the output buffer is enabled. Data on the SPDIN pin is sampled on each clock.
- After 8 SPI_CLK pulses from the second receive byte:
 - The second SPI cycle is complete, RXBF bit is asserted '1', and the SPINT interrupt is asserted, if enabled. The data now contained in SPIRD - SPI RX_Data Register is the second half of the 16 bit word containing the temperature data.
 - Once the first SPI cycle is completed, the SPI master takes the pending data in the TX_DATA register (command byte 1) and loads it into the TX shift register. Loading the shift register automatically asserts the TXFE bit, begins shifting the dummy data value onto the SPDOUT pin, and drives the SPI_CLK pin. Data on the SPDIN pin is also sampled on each clock.
- Once the TXFE bit is asserted the SPI Master is ready to receive its next byte. Before writing the next TX_DATA value, software must clear the RXBF status bit by reading the SPIRD - SPI RX_Data Register.
- Next, the second command byte is written to the TX_DATA register. The SPI master automatically clears the TXFE bit, but does not begin shifting the command data value onto the SPDOUT pin. This byte will remain in the TX_DATA register until the TX shift register is empty.
- After 8 SPI_CLK pulses from the first transmit byte:
 - The third SPI cycle is complete, RXBF bit is asserted '1', and the SPINT interrupt is asserted, if enabled. The data now contained in SPIRD - SPI RX_Data Register is invalid, since this command was used to transmit the first command byte to the SPI slave.
 - Once the first SPI cycle is completed, the SPI master takes the pending data in the TX_DATA register (command byte 2) and loads it into the TX shift register. Loading the shift register automatically asserts the TXFE bit, begins shifting the dummy data value onto the SPDOUT pin, and drives the SPI_CLK pin. Data on the SPDIN pin is also sampled on each clock.
- Once the TXFE bit is asserted the SPI Master is ready to transmit or receive its next byte. Before writing the next TX_DATA value, software must clear the RXBF status bit by reading the SPIRD - SPI RX_Data Register.
- Since no more data needs to be transmitted, the host software will wait for the RXBF status bit to be asserted indicating the second command byte was transmitted successfully.
- CS# is de-asserted.

39.12 EC-Only/Runtime Registers

Registers for this block are shown in the following summary table. Addresses for each register are determined by adding the offset to the Base Address for each instance of the [General Purpose Serial Peripheral Interface](#) Block in the Block Overview and Base Address Table in [Section 3.0, "Device Inventory"](#).

TABLE 39-6: REGISTER SUMMARY

Offset	Register Name
0h	SPI Enable Register
4h	SPI Control Register
8h	SPI Status Register
Ch	SPI TX_Data Register
10h	SPI RX_Data Register
14h	SPI Clock Control Register
18h	SPI Clock Generator Register

MEC1725

39.12.1 SPI ENABLE REGISTER

Offset	00h			
Bits	Description	Type	Default	Reset Event
31:1	Reserved	R	-	-
0	ENABLE 1=Enabled. The device is fully operational 0=Disabled. Clocks are gated to conserve power and the SPDOOUT and SPI_CLK signals are set to their inactive state	R/W	0h	RESET_SYS

39.12.2 SPI CONTROL REGISTER

Offset	04h			
Bits	Description	Type	Default	Reset Event
31:7	Reserved	R	-	-
6	CE SPI Chip Select Enable. 1=SPI_CS# output signal is asserted, i.e., driven to logic '0' 0=SPI_CS# output signal is deasserted, i.e., driven to logic '1'	R/W	0h	RESET_SYS
5	AUTO_READ Auto Read Enable. 1=A read of the SPI RX_DATA Register will clear both the RXBF status bit and the TXBE status bit 0=A read of the SPI RX_DATA Register will clear the RXBF status bit. The TXBE status bit will not be modified	R/W	0h	RESET_SYS
4	SOFT_RESET Soft Reset is a self-clearing bit. Writing zero to this bit has no effect. Writing a one to this bit resets the entire SPI Interface, including all counters and registers back to their initial state.	R/W	0h	RESET_SYS
3:2	SPDIN_SELECT The SPDIN Select which SPI input signals are enabled when the BIOEN bit is configured as an input. 1xb=SPDIN1 and SPDIN2. Select this option for Dual Mode 01b=SPDIN2 only. Select this option for Half Duplex 00b=SPDIN1 only. Select this option for Full Duplex	R/W	0h	RESET_SYS

Offset	04h			
Bits	Description	Type	Default	Reset Event
1	<p>BIOEN Bidirectional Output Enable control. When the SPI is configured for Half Duplex mode or Dual Mode the SPDOOUT pin operates as a bi-directional signal. The BIOEN bit is used by the internal DIRECTION bit to control the direction of the SPDOOUT buffers. The direction of the buffer is never changed while a byte is being transmitted.</p> <p>1=The SPDOOUT_Direction signal configures the SPDOOUT signal as an output. 0=The SPDOOUT_Direction signal configures the SPDOOUT signal as an input.</p> <p>See Section 39.10.4, "How BIOEN Bit Controls Direction of SPDOOUT Buffer" for details on the use of BIOEN.</p>	R/W	1h	RESET_SYS_
0	<p>LSBF Least Significant Bit First</p> <p>1=The data is transferred in LSB-first order. 0=The data is transferred in MSB-first order. (default)</p>	R/W	0h	RESET_SYS_

39.12.3 SPI STATUS REGISTER

Offset	08h			
Bits	Description	Type	Default	Reset Event
31:3	Reserved	R	-	-
2	ACTIVE	R	0h	RESET_SYS_
1	<p>RXBF Receive Data Buffer Full status. When this bit is '1' the Rx_Data buffer is full. Reading the SPI RX_Data Register clears this bit. This signal may be used to generate a SPI_RX interrupt to the EC.</p> <p>1=RX_Data buffer is full 0=RX_Data buffer is not full</p>	R	0h	RESET_SYS_
0	<p>TXBE Transmit Data Buffer Empty status. When this bit is '1' the Tx_Data buffer is empty. Writing the SPI TX_Data Register clears this bit. This signal may be used to generate a SPI_TX interrupt to the EC.</p> <p>1=TX_Data buffer is empty 0=TX_Data buffer is not empty</p>	R	1h	RESET_SYS_

MEC1725

39.12.4 SPI TX_DATA REGISTER

Offset	0Ch			
Bits	Description	Type	Default	Reset Event
31:8	Reserved	R	-	-
7:0	<p>TX_DATA</p> <p>A write to this register when the Tx_Data buffer is empty (TXBE in the SPI Status Register is '1') initiates a SPI transaction. The byte written to this register will be loaded into the shift register and the TXBE flag will be asserted. This indicates that the next byte can be written into the TX_DATA register. This byte will remain in the TX_DATA register until the SPI core has finished shifting out the previous byte. Once the shift register is empty, the hardware will load the pending byte into the shift register and once again assert the TxBE bit.</p> <p>The TX_DATA register must not be written when the TXBE bit is zero. Writing this register may overwrite the transmit data before it is loaded into the shift register.</p>	R/W	0h	RESET_SYS

39.12.5 SPI RX_DATA REGISTER

Offset	10h			
Bits	Description	Type	Default	Reset Event
31:8	Reserved	R	-	-
7:0	<p>RX_DATA</p> <p>This register is used to read the value returned by the external SPI device. At the end of a byte transfer the RX_DATA register contains serial input data (valid or not) from the last transaction and the RXBF bit is set to one. This status bit indicates that the RX_DATA register has been loaded with a the serial input data. The RX_DATA register should not be read before the RXBF bit is set.</p> <p>The RX_DATA register must be read, clearing the RXBF status bit before writing the TX_DATA register. The data in the receive shift register is only loaded into the RX_DATA register when this bit is cleared. If a data byte is pending in the receive shift register the value will be loaded immediately into the RX_DATA register and the RXBF status flag will be asserted. Software should read the RX_DATA register twice before starting a new transaction to make sure the RX_DATA buffer and shift register are both empty.</p>	R/W	0h	RESET_SYS

39.12.6 SPI CLOCK CONTROL REGISTER

This register should not be changed during an active SPI transaction.

Offset	14h			
Bits	Description	Type	Default	Reset Event
31:5	Reserved	R	-	-
4	<p>CLKSRC</p> <p>Clock Source for the SPI Clock Generator. This bit should not be changed during a SPI transaction. When the field PRELOAD in the SPI Clock Generator Register is 0, this bit is ignored and the Clock Source is always the main system clock (the equivalent of setting this bit to '0').</p> <p>1=2MHz 0=48MHz</p>	R/W	0h	RESET_SYS
3	Reserved	R	-	-
2	<p>CLKPOL</p> <p>SPI Clock Polarity.</p> <p>1=The SPI_CLK signal is high when the interface is idle and the first clock edge is a falling edge 0=The SPI_CLK is low when the interface is idle and the first clock edge is a rising edge</p>	R/W	0h	RESET_SYS
1	<p>RCLKPH</p> <p>Receive Clock Phase, the SPI_CLK edge on which the master will sample data. The receive clock phase is not affected by the SPI Clock Polarity.</p> <p>1=Valid data on SPDIN signal is expected after the first SPI_CLK edge. This data is sampled on the second and following even SPI_CLK edges (i.e., sample data on falling edge) 0=Valid data is expected on the SPDIN signal on the first SPI_CLK edge. This data is sampled on the first and following odd SPI_CLK edges (i.e., sample data on rising edge)</p>	R/W	1h	RESET_SYS
0	<p>TCLKPH</p> <p>Transmit Clock Phase, the SPCLK edge on which the master will clock data out. The transmit clock phase is not affected by the SPI Clock Polarity.</p> <p>1=Valid data is clocked out on the first SPI_CLK edge on SPDOUT signal. The slave device should sample this data on the second and following even SPI_CLK edges (i.e., sample data on falling edge) 0=Valid data is clocked out on the SPDOUT signal prior to the first SPI_CLK edge. The slave device should sample this data on the first and following odd SPI_CLK edges (i.e., sample data on rising edge)</p>	R/W	0h	RESET_SYS

MEC1725

39.12.7 SPI CLOCK GENERATOR REGISTER

Offset	18h			
Bits	Description	Type	Default	Reset Event
31:16	Reserved	R	-	-
5:0	PRELOAD SPI Clock Generator Preload value.	R/W	2h	RESET_ SYS_

40.0 BC-LINK MASTER

40.1 Overview

This block provides BC-Link™ connectivity to a slave device. The BC-Link™ protocol includes a start bit to signal the beginning of a message and a turnaround (TAR) period for bus transfer between the Master and Companion devices.

40.2 References

No references have been cited for this feature.

40.3 Terminology

There is no terminology defined for this section.

40.4 Interface

This block is designed to be accessed externally via the pin interface and internally via a registered host interface.

FIGURE 40-1: I/O DIAGRAM OF BLOCK

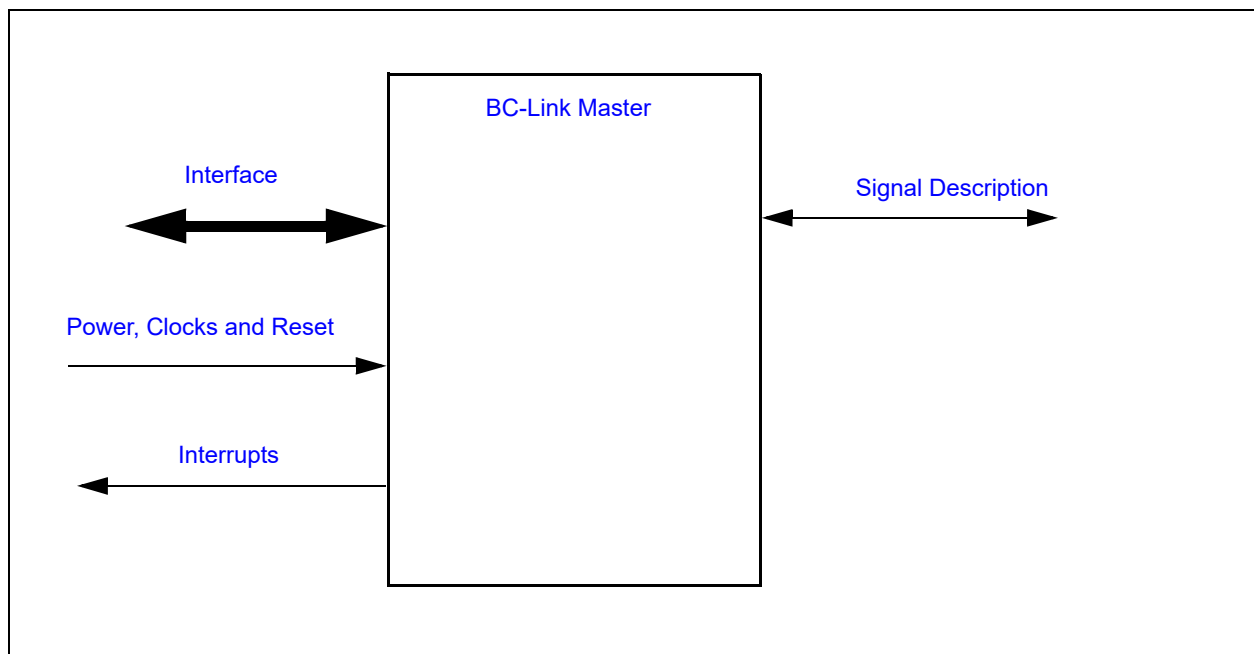

40.5 Signal Description

TABLE 40-1: SIGNAL DESCRIPTION

Name	Direction	Description
BCM_CLK	Output	BC-Link output clock
BCM_DAT	Input/Output	Bidirectional data line

Note: A weak pull-up resistor is recommended on the data line (100KW).

The maximum speed at which the BC-Link Master Interface can operate reliably depends on the drive strength of the BC-Link BCM_CLK and BCM_DAT pins, as well as the nature of the connection to the Companion device (over ribbon cable or on a PC board). The following table shows the recommended maximum speeds over a PC board as well as a 12 inch ribbon cable for selected drive strengths. The frequency is set with the [BC-Link Clock Select Register](#).

MEC1725

There is no explicit BC-Link INT# input signal. Any GPIO input can be used to generate an interrupt from a BC-Link companion's INT# output.

TABLE 40-2: BC-LINK MASTER PIN DRIVE STRENGTH VS. FREQUENCY

Pin Drive Strength	Max Freq on PC Board	Min Value in BC-Link Clock Select Register	Max Freq over Ribbon cable	Min Value in BC-Link Clock Select Register
12mA	24Mhz	1	16Mhz	2
8mA	3MHz	15	3MHz	15

40.6 Host Interface

The registers defined for the BC-Link Master Interface are accessible by the various hosts as indicated in [Section 40.11, "EC Registers"](#).

40.7 Power, Clocks and Reset

40.7.1 POWER DOMAINS

Name	Description
VTR_CORE	The logic and registers implemented in this block are powered by this power well.

40.7.2 CLOCK INPUTS

Name	Description
48MHz	This is the clock source for this block.

40.7.3 RESETS

Name	Description
RESET_SYS	This signal resets all the registers and logic in this block to their default state.

40.8 Interrupts

This section defines the Interrupt Sources generated from this block.

Source	Description
BCM_INT Busy	Interrupt request to the Interrupt Aggregator, generated from the status event BUSY defined in the BC-Link Status Register .
BCM_INT Err	Interrupt request to the Interrupt Aggregator, generated from the status event defined in the BC-Link Status Register .

40.9 Low Power Modes

The BC-Link Master Interface automatically enters a low power mode whenever it is not active (that is, whenever the [BUSY](#) bit in the [BC-Link Status Register](#) is '0'). When the interface is in a low-power mode it will not prevent the chip from entering a sleep state. When the interface is active it will inhibit the chip sleep state until the interface has re-entered its low power mode.

40.10 Description

FIGURE 40-2: BC-LINK MASTER BLOCK DIAGRAM

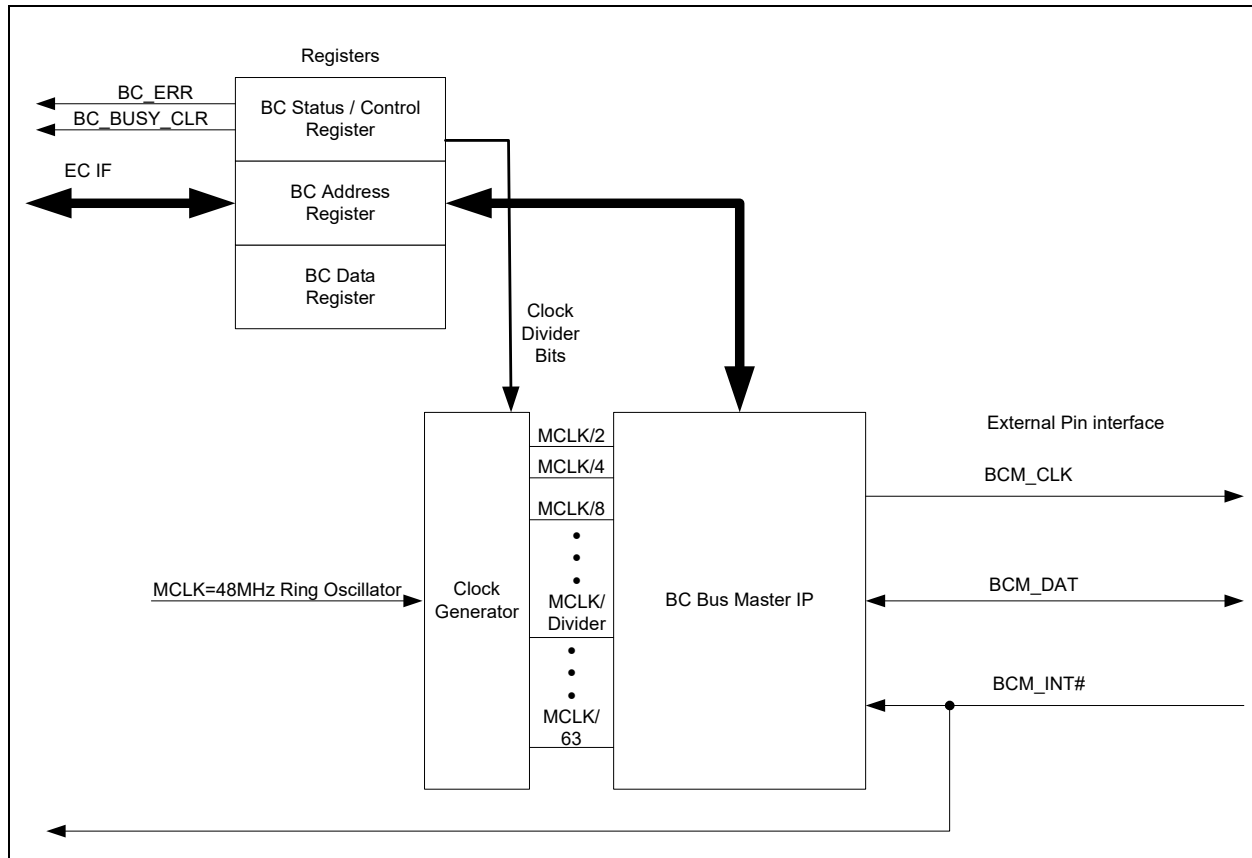

40.10.1 BC-LINK MASTER READ OPERATION

The BC-Link Read protocol requires two reads of the [BC-Link Data Register](#). The two reads drive a two state-state machine: the two states are Read#1 and Read#2. The Read#1 of the Data Register starts the read protocol on the BC-Link pins and sets the **BUSY** bit in the [BC-Link Status Register](#). The contents of the data read during Read#1 by the EC is stale and is not to be used. After the **BUSY** bit in the BC-Link Status Register autonomously clears to '0', the Read#2 of the Data Register transfers the data read from the peripheral/BC-Link companion chip to the EC.

1. Software starts by checking the status of the **BUSY** bit in the Status Register. If the **BUSY** bit is '0', proceed. If **BUSY** is '1', firmware must wait until it is '0'.
2. Software writes the address of the register to be read into the [BC-Link Address Register](#).
3. Software then reads the Data Register. This read returns random data. The read activates the BC-Link Master state machine to transmit the read request packet to the BC-Link companion. When the transfer initiates, the hardware sets the **BUSY** bit to a '1'.
4. The BC-Link Companion reads the selected register and transmits the read response packet to the BC-Link Master. The Companion will ignore the read request if there is a CRC error; this will cause the Master state machine to time-out and issue a **BC_ERR** Interrupt.
5. The Master state machine loads the Data Register, issues a **BUSY** Bit Clear interrupt and clears the **BUSY** bit to '0'.
6. Software, after either receiving the Bit Clear interrupt, or polling the **BUSY** bit until it is '0', checks the **BC_ERR** bit in the Status Register.
7. Software can now read the Data Register which contains the valid data if there was no BC Bus error.
8. If a Bus Error occurs, firmware must issue a soft reset by setting the [RESET](#) bit in the Status Register to '1'.
9. The read can re-tried once **BUSY** is cleared.

Note: Steps 3 through 7 should be completed as a contiguous sequence. If not the interface could be presenting incorrect data when software thinks it is accessing a valid register read.

40.10.2 BC-LINK MASTER WRITE OPERATION

1. Software starts by checking the status of the **BUSY** bit in the **BC-Link Status Register**. If the **BUSY** bit is '0', proceed. If **BUSY** is '1', firmware must wait until it is '0'.
2. Software writes the address of the register to be written into the **BC-Link Address Register**.
3. Software writes the data to be written into the addressed register in to the **BC-Link Data Register**.
4. The write to the Data Register starts the BC_Link write operation. The Master state machine sets the **BUSY** bit.
5. The **BC-Link Master** Interface transmits the write request packet.
6. When the write request packet is received by the BC-Link companion, the CRC is checked and data is written to the addressed companion register.
7. The companion sends an ACK if the write is completed. A time-out will occur approximately 16 BC-Link clocks after the packet is sent by the Master state machine. If a time-out occurs, the state machine will set the **BC_ERR** bit in the Status Register to '1' approximately 48 clocks later and then clear the **BUSY** bit.
8. The Master state machine issues the Bit Clear interrupt and clears the **BUSY** bit after receiving the ACK from the Companion
9. If a Bus Error occurs, firmware must issue a soft reset by setting the **RESET** bit in the Status Register to '1'.
10. The write can re-tried once **BUSY** is cleared.\

40.11 EC Registers

Registers for this block are shown in the following summary table. Addresses for each register are determined by adding the offset to the Base Address for each instance of the **BC-Link Master** Block in the Block Overview and Base Address Table in [Section 3.0, "Device Inventory"](#).

TABLE 40-3: REGISTER SUMMARY

EC Offset	Register Name
00h	BC-Link Status Register
04h	BC-Link Address Register
08h	BC-Link Data Register
0Ch	BC-Link Clock Select Register

40.11.1 BC-LINK STATUS REGISTER

Offset	00h			
Bits	Description	Type	Default	Reset Event
31:8	Reserved	R	-	-
7	<p>RESET</p> <p>When this bit is '1' the BC_Link Master Interface will be placed in reset and be held in reset until this bit is cleared to '0'. Setting RESET to '1' causes the BUSY bit to be set to '1'. The BUSY remains set to '1' until the reset operation of the BC Interface is completed, which takes approximately 48 BC clocks.</p> <p>The de-assertion of the BUSY bit on reset will not generate an interrupt, even if the BC_BUSY_CLR_INT_EN bit is '1'. The BUSY bit must be polled in order to determine when the reset operation has completed.</p>	R/W	1h	RESET_SYS
6	<p>BC_ERR</p> <p>This bit indicates that a BC Bus Error has occurred. If an error occurs this bit is set by hardware when the BUSY bit is cleared. This bit is cleared when written with a '1b'. An interrupt is generated if this bit is '1' and BC_ERR_INT_EN bit is '1b'. Errors that cause this interrupt are:</p> <ul style="list-style-type: none"> • Bad Data received by the BASE (CRC Error) • Time-out caused by the COMPANION not responding. <p>All COMPANION errors cause the COMPANION to abort the operation and the BASE to time-out. Figure 40.11.2</p>	R/WC	0h	RESET_SYS
5	<p>BC_ERR_INT_EN</p> <p>This bit is an enable for generating an interrupt when the BC_ERR bit is set by hardware. When this bit is '1', the interrupt signal is enabled. When this bit is '0', the interrupt is disabled.</p>	R/W	0h	RESET_SYS
4	<p>BC_BUSY_CLR_INT_EN</p> <p>This bit is an enable for generating an interrupt when the BUSY bit in this register is cleared by hardware. When this bit is set to '1', the interrupt signal is enabled. When the this bit is cleared to '0', the interrupt is disabled. When enabled, the interrupt occurs after a BC Bus read or write.</p>	R/W	0h	RESET_SYS
3:1	Reserved	R	-	-
0	<p>BUSY</p> <p>This bit is asserted to '1' when the BC interface is transferring data and on reset. Otherwise it is cleared to '0'. When this bit is cleared by hardware, an interrupt is generated if the BC_BUSY_CLR_INT_EN bit is set to '1'.</p>	R	1h	RESET_SYS

MEC1725

40.11.2 BC-LINK ADDRESS REGISTER

Offset	04h			
Bits	Description	Type	Default	Reset Event
31:8	Reserved	R	-	-
7:0	ADDRESS Address in the Companion for the BC-Link transaction.	R/W	0h	RESET _SYS

40.11.3 BC-LINK DATA REGISTER

Offset	08h			
Bits	Description	Type	Default	Reset Event
31:8	Reserved	R	-	-
7:0	DATA As described in Section 40.10.1, "BC-Link Master READ Operation" and Section 40.10.2, "BC-Link Master WRITE Operation" , this register hold data used in a BC-Link transaction.	R/W	0h	RESET _SYS

40.11.4 BC-LINK CLOCK SELECT REGISTER

Offset	0Ch			
Bits	Description	Type	Default	Reset Event
31:8	Reserved	R	-	-
7:0	DIVIDER The BC Clock is set to the Master Clock divided by this field, or 48MHz/ (Divider +1). The clock divider bits can only be changed when the BC Bus is in soft RESET (when either the Reset bit is set by software or when the BUSY bit is set by the interface). Example settings for DIVIDER are shown in Table 40-4, "Example Frequency Settings" .	R/W	4h	RESET _SYS

TABLE 40-4: EXAMPLE FREQUENCY SETTINGS

Divider	Frequency
0	48MHz
1	24MHz
2	16MHz
3	12MHz
4	9.6MHz
6	6.9MHz
15	3MHz
47	1MHz

MEC1725

41.0 PS/2 INTERFACE

41.1 Introduction

PS/2 controllers are directly controlled by the EC. The hardware implementation eliminates the need to bit bang I/O ports to generate PS/2 traffic, however bit banging is available via the associated GPIO pins.

41.2 References

No references have been cited for this feature.

41.3 Interface

This block is designed to be accessed externally via the pin interface and internally via a registered host interface.

FIGURE 41-1: I/O DIAGRAM OF BLOCK

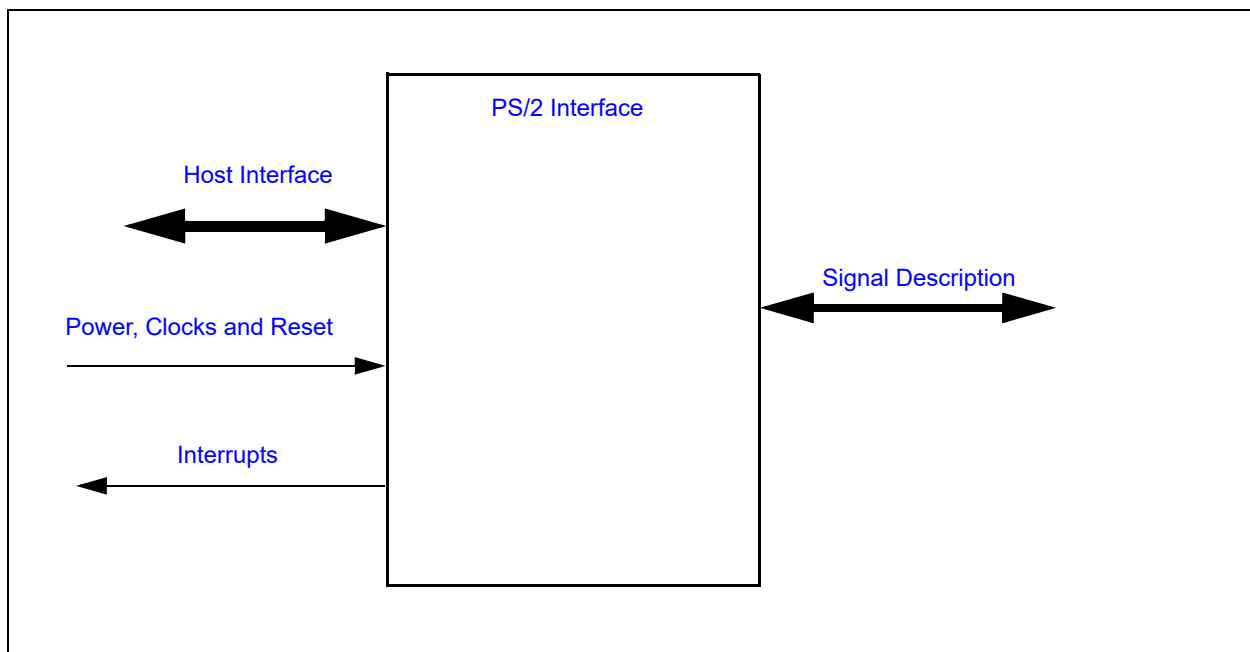

41.4 Signal Description

TABLE 41-1: SIGNAL DESCRIPTION TABLE

Name	Direction	Description
PS2_DAT	INPUT/ OUTPUT	Data from the PS/2 device
PS2_CLK	INPUT/ OUTPUT	Clock from the PS/2 device

41.5 Host Interface

The registers defined for the PS/2 Interface are accessible by the various hosts as indicated in [Section 3.2, "Block Overview and Base Addresses"](#).

41.6 Power, Clocks and Reset

This section defines the Power, Clock, and Reset parameters of the block.

41.6.1 POWER DOMAINS

Name	Description
VTR_CORE	The logic and registers implemented in this block are powered by this power well.

41.6.2 CLOCK INPUTS

Name	Description
48MHz	This is the clock source for PS/2 Interface logic.
2 MHz Clock	The PS/2 state machine is clocked using the 2 MHz clock.

41.6.3 RESETS

Name	Description
RESET_SYS	This signal resets all the registers and logic in this block to their default state.

41.7 Interrupts

This section defines the Interrupt Sources generated from this block.

Source	Description
PS2_x_ACT	Interrupt request to the Interrupt Aggregator for PS2 controller instance x, based on PS2 controller activity. Section 41.13.4, "PS2 Status Register" defines the sources for the interrupt request.
PS2_x_WK	Wake-up request to the Interrupt Aggregator's wake-up interface for PS2 port x. In order to enable PS2 wakeup interrupts, the pin control registers for the PS2DAT pin must be programmed to Input, Falling Edge Triggered, non-inverted polarity detection.

41.8 Low Power Modes

The PS/2 Interface may be put into a low power state by the chip's Power, Clocks, and Reset (PCR) circuitry.

When set to be in Low power mode, PS2 interface will only sleep while the PS2 is disabled or in Rx mode with no traffic on the bus.

41.9 Description

Each EC PS/2 serial channels use a synchronous serial protocol to communicate with the auxiliary device. Each PS/2 channel has Clock and Data signal lines. The signal lines are bi-directional and employ open drain outputs capable of sinking 12mA, as required by the PS/2 specification. A pull-up resistor, typically 10K, is connected to both lines. This allows either the EC PS/2 logic or the auxiliary device to drive the lines. Regardless of the drive source, the auxiliary device always provides the clock for transmit and receive operations. The serial packet is made up of eleven bits, listed in the order they appear on the data line: start bit, eight data bits (least significant bit first), odd parity, and stop bit. Each bit cell is from 60µS to 100µS long.

All PS/2 Serial Channel signals (PS2CLK and PS2DAT) are driven by open drain drivers which can be pulled to [VTR1](#) or the main power rail (+3.3V nominal) through 10K-ohm resistors.

The PS/2 controller supports a PS/2 Wake Interface that can wake the EC from the IDLE or SLEEP states. The Wake Interface can generate wake interrupts without a clock. The PS/2 Wake Interface is only active when the peripheral device and external pull-up resistors are powered by the [VTR1](#) supply.

MEC1725

There are no special precautions to be taken to prevent back drive of a PS/2 peripheral powered by the main power well when the power well is off, as long as the external 10K pull-up resistor is tied to the same power source as the peripheral. PS/2 controllers may have one or two ports. Only one port may be active at a time. See the pin chapter for a definition of the PS/2 ports.

41.10 Block Diagram

FIGURE 41-2: PORT PS/2 BLOCK DIAGRAM

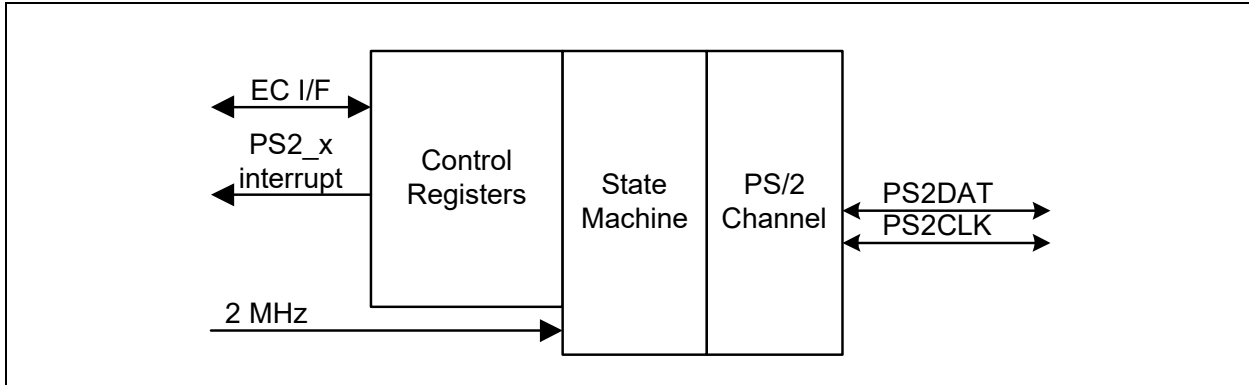

41.11 PS/2 Port Physical Layer Byte Transmission Protocol

The PS/2 physical layer transfers a byte of data via an eleven bit serial stream as shown in Table 41-2. A logic 1 is sent at an active high level. Data sent from a Keyboard or mouse device to the host is read on the falling edge of the clock signal. The Keyboard or mouse device always generates the clock signal. The Host may inhibit communication by pulling the Clock line low. The Clock line must be continuously high for at least 50 microseconds before the Keyboard or mouse device can begin to transmit its data. See Table 41-3, "PS/2 Port Physical Layer Bus States".

TABLE 41-2: PS/2 PORT PHYSICAL LAYER BYTE TRANSMISSION PROTOCOL

Bit	Function
1	Start bit (always 0)
2	Data bit 0 (least significant bit)
3	Data bit 1
4	Data bit 2
5	Data bit 3
6	Data bit 4
7	Data bit 5
8	Data bit 6
9	Data bit 7 (most significant bit)
10	Parity bit (odd parity)
11	Stop Bit (always 1)

FIGURE 41-3: PS/2 PORT PHYSICAL LAYER BYTE TRANSMISSION PROTOCOL

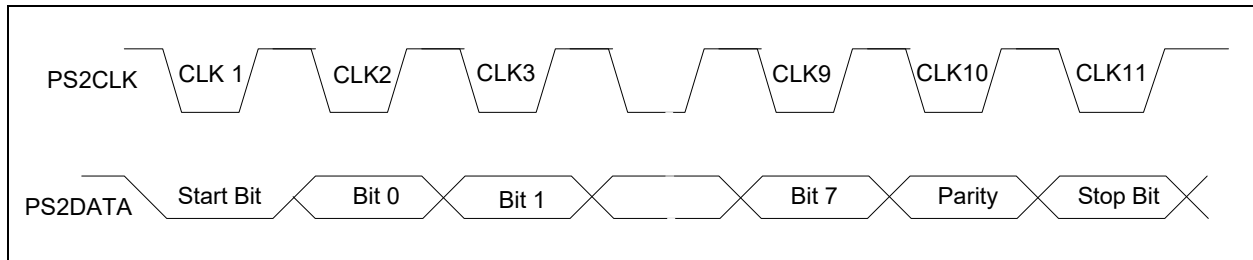

TABLE 41-3: PS/2 PORT PHYSICAL LAYER BUS STATES

Data	Clock	State
high	high	Idle
high	low	Communication Inhibited
low	low	Request to Send

41.12 Controlling PS/2 Transactions

PS/2 transfers are controlled by fields in the [PS2 Control Register](#).

The interface is enabled by the [PS2_EN](#) bit. Transfers are enabled when PS2_EN is '1' and disabled when PS2_EN is '0'. If the PS2_EN bit is cleared to '0' while a transfer is in progress but prior to the leading edge (falling edge) of the 10th (parity bit) clock edge, the receive data is discarded (RDATA_RDY remains low). If the PS2_EN bit is cleared following the leading edge of the 10th clock signal, then the receive data is saved in the Receive Register (RDATA_RDY goes high) assuming no parity error.

The direction of a PS/2 transfer is controlled by the [PS2_T/R](#) bit.

41.12.1 RECEIVE

If PS2_T/R is '0' while the PS2 Interface is enabled, the interface is configured to receive data. If while PS2_T/R is '0' RDATA_RDY is '0', the channel's PS2CLK and PS2DAT will float waiting for the external PS/2 device to signal the start of a transmission. If RDATA_RDY is '1', the channel's PS2DAT line will float but its PS2CLK line will be held low, holding off the peripheral, until the Receive Register is read.

The peripheral initiates a reception by sending a start bit followed by the data bits. After a successful reception, data are placed in the [PS2 Receive Buffer Register](#), the RDATA_RDY bit in the [PS2 Status Register](#) is set and the PS2CLK line is forced low. Further receive transfers are inhibited until the EC reads the data in the PS2 Receive Buffer Register. RDATA_RDY is cleared and the PS2CLK line is tri-stated following a read of the PS2 Receive Buffer Register.

The Receive Buffer Register is initialized to FFh after a read or after a Time-out has occurred.

41.12.2 TRANSMIT

If PS2_T/R is '1' while the PS2 Interface is enabled, the interface is configured to transmit data. When the PS2_T/R bit is written to '1' while the state machine is idle, the channel prepares for a transmission: the interface will drive the PS2-CLK line low and then float the PS2DAT line, holding this state until a write occurs to the Transmit Register or until the PS2_T/R bit is cleared. A transmission is started by writing the [PS2 Transmit Buffer Register](#). Writes to the Transmit Buffer Register are blocked when PS2_EN is '0', PS2_T/R is '0' or when the transmit state machine is active (the XMIT_IDLE bit in the PS/2 Status Register is '0'). The transmission of data will not start if there is valid data in the Receive Data Register (when the status bit RDATA_RDY is '1'). When a transmission is started, the transmission state machine becomes active (the XMIT_IDLE bit is set to '1' by hardware), the PS2DAT line is driven low and within 80ns the PS2CLK line floats (externally pulled high by the pull-up resistor).

The transmission terminates either on the 11th clock edge of the transmission or if a Transmit Time-Out error condition occurs. When the transmission terminates, the PS2_T/R bit is cleared to '0' and the state machine becomes idle, setting XMIT_IDLE to '1'.

MEC1725

The PS2_T/R bit must be written to a '1' before initiating another transmission to the remote device. If the PS2_T/R bit is set to '1' while the channel is actively receiving data (that is, while the status bit RDATA_RDY is '1') prior to the leading edge of the 10th (parity bit) clock edge, the receive data is discarded. If the bit is set after the 10th edge, the receive data is saved in the Receive Register.

41.13 EC Registers

Registers for this block are shown in the following summary table. Addresses for each register are determined by adding the offset to the Base Address for each instance of the [PS/2 Interface](#) Block in the Block Overview and Base Address Table in [Section 3.0, "Device Inventory"](#).

TABLE 41-4: REGISTER SUMMARY

Offset	Register Name
0h	PS2 Transmit Buffer Register
0h	PS2 Receive Buffer Register
4h	PS2 Control Register
8h	PS2 Status Register

41.13.1 PS2 TRANSMIT BUFFER REGISTER

Offset	00h			
Bits	Description	Type	Default	Reset Event
31:8	Reserved	RES	-	-
7:0	TRANSMIT_DATA Writes to this register start a transmission of the data in this register to the peripheral.	W	0h	RESET_SYS

41.13.2 PS2 RECEIVE BUFFER REGISTER

Offset	00h			
Bits	Description	Type	Default	Reset Event
31:8	Reserved	RES	-	-
7:0	RECEIVE_DATA Data received from a peripheral are recorded in this register. A transmission initiated by writing the PS2 Transmit Buffer Register will not start until valid data in this register have been read and RDATA_RDY has been cleared by hardware. The Receive Buffer Register is initialized to FFh after a read or after a Time-out has occurred.	R	FFh	RESET_SYS

41.13.3 PS2 CONTROL REGISTER

Offset	00h			
Bits	Description	Type	Default	Reset Event
31:6	Reserved	RES	-	-
5:4	<p>STOP</p> <p>These bits are used to set the level of the stop bit expected by the PS/2 channel state machine. These bits are therefore only valid when PS2_EN is set.</p> <p>00b=Receiver expects an active high stop bit. 01b=Receiver expects an active low stop bit. 10b=Receiver ignores the level of the Stop bit (11th bit is not interpreted as a stop bit). 11b=Reserved.</p>	R/W	0h	RESET_SYS
3:2	<p>PARITY</p> <p>These bits are used to set the parity expected by the PS/2 channel state machine. These bits are therefore only valid when PS2_EN is set.</p> <p>00b=Receiver expects Odd Parity (default). 01b=Receiver expects Even Parity. 10b=Receiver ignores level of the parity bit (10th bit is not interpreted as a parity bit). 11b=Reserved</p>	R/W	0h	RESET_SYS
1	<p>PS2_EN</p> <p>PS/2 Enable.</p> <p>0=The PS/2 state machine is disabled. The CLK pin is driven low and the DATA pin is tri-stated. 1=The PS/2 state machine is enabled, allowing the channel to perform automatic reception or transmission, depending on the state of PS2_T/R.</p>	R/W	0h	RESET_SYS
0	<p>PS2_T/R</p> <p>PS/2 Transmit/Receive</p> <p>0=The P2/2 channel is enabled to receive data. 1=The PS2 channel is enabled to transmit data.</p>	R/W	0h	RESET_SYS

Changing values in the PS2 CONTROL REGISTER at a rate faster than 2 MHz, may result in unpredictable behavior.

MEC1725

41.13.4 PS2 STATUS REGISTER

Offset	08h			
Bits	Description	Type	Default	Reset Event
31:8	Reserved	RES	-	-
7	<p>XMIT_START_TIMEOUT Transmit Start Timeout.</p> <p>0=No transmit start timeout detected 1=A start bit was not received within 25 ms following the transmit start event. The transmit start bit time-out condition is also indicated by the XMIT_TIMEOUT bit.</p>	R/WC	0h	RESET_SYS
6	<p>RX_BUSY Receive Channel Busy.</p> <p>0=The channel is idle 1=The channel is actively receiving PS/2 data</p>	R	0h	RESET_SYS
5	<p>XMIT_TIMEOUT</p> <p>When the XMIT_TIMEOUT bit is set, the PS2_T/R bit is held clear, the PS/2 channel's CLK line is pulled low for a minimum of 300µs until the PS/2 Status register is read. The XMIT_TIMEOUT bit is set on one of three transmit conditions: when the transmitter bit time (the time between falling edges) exceeds 300µs, when the transmitter start bit is not received within 25ms from signaling a transmit start event or if the time from the first bit (start) to the 10th bit (parity) exceeds 2ms</p>	R/WC	0h	RESET_SYS
4	<p>XMIT_IDLE Transmitter Idle.</p> <p>0=The channel is actively transmitting PS/2 data. Writing the PS2 Transmit Buffer Register will cause the XMIT_IDLE bit to clear 1=The channel is not transmitting. This bit transitions from '0' to '1' in the following cases:</p> <ul style="list-style-type: none"> • The falling edge of the 11th CLK • XMIT_TIMEOUT is set • The PS2_T/R bit is cleared • The PS2_EN bit is cleared. <p>A low to high transition on this bit generates a PS2 Activity interrupt.</p>	R	1h	RESET_SYS
3	<p>FE Framing Error</p> <p>When receiving data, the stop bit is clocked in on the falling edge of the 11th CLK edge. If the channel is configured to expect either a high or low stop bit and the 11th bit is contrary to the expected stop polarity, then the FE and REC_TIMEOUT bits are set following the falling edge of the 11th CLK edge and an interrupt is generated.</p>	R/WC	0h	RESET_SYS

Offset	08h			
Bits	Description	Type	Default	Reset Event
2	<p>PE Parity Error</p> <p>When receiving data, the parity bit is clocked in on the falling edge of the 10th CLK edge. If the channel is configured to expect either even or odd parity and the 10th bit is contrary to the expected parity, then the PE and REC_TIMEOUT bits are set following the falling edge of the 10th CLK edge and an interrupt is generated.</p>	R/WC	0h	RESET_SYS
1	<p>REC_TIMEOUT Receive Timeout</p> <p>Following assertion of the REC_TIMEOUT bit, the channel's CLK line is automatically pulled low for a minimum of 300µs until the PS/2 status register is read. Under PS2 automatic operation, PS2_EN is set, this bit is set on one of three receive error conditions:</p> <ul style="list-style-type: none"> • When the receiver bit time (the time between falling edges) exceeds 300µs. • If the time from the first bit (start) to the 10th bit (parity) exceeds 2ms. • On a receive parity error along with the Parity Error (PE) bit. • On a receive framing error due to an incorrect STOP bit along with the framing error (FE) bit. <p>A low to high transition on this bit generates a PS2 Activity interrupt.</p>	R/WC	0h	RESET_SYS
0	<p>RDATA_RDY Receive Data Ready</p> <p>Under normal operating conditions, this bit is set following the falling edge of the 11th clock given successful reception of a data byte from the PS/2 peripheral (i.e., no parity, framing, or receive timeout errors) and indicates that the received data byte is available to be read from the Receive Register. This bit may also be set in the event that the PS2_EN bit is cleared following the 10th CLK edge.</p> <p>Reading the Receive Register clears this bit.</p> <p>A low to high transition on this bit generates a PS2 Activity interrupt.</p>	R	0h	RESET_SYS

MEC1725

42.0 TRACE FIFO DEBUG PORT (TFDP)

42.1 Introduction

The TFDP serially transmits Embedded Controller (EC)-originated diagnostic vectors to an external debug trace system.

42.2 References

No references have been cited for this chapter.

42.3 Interface

This block is designed to be accessed externally via the pin interface and internally via a registered host interface.

FIGURE 42-1: I/O DIAGRAM OF BLOCK

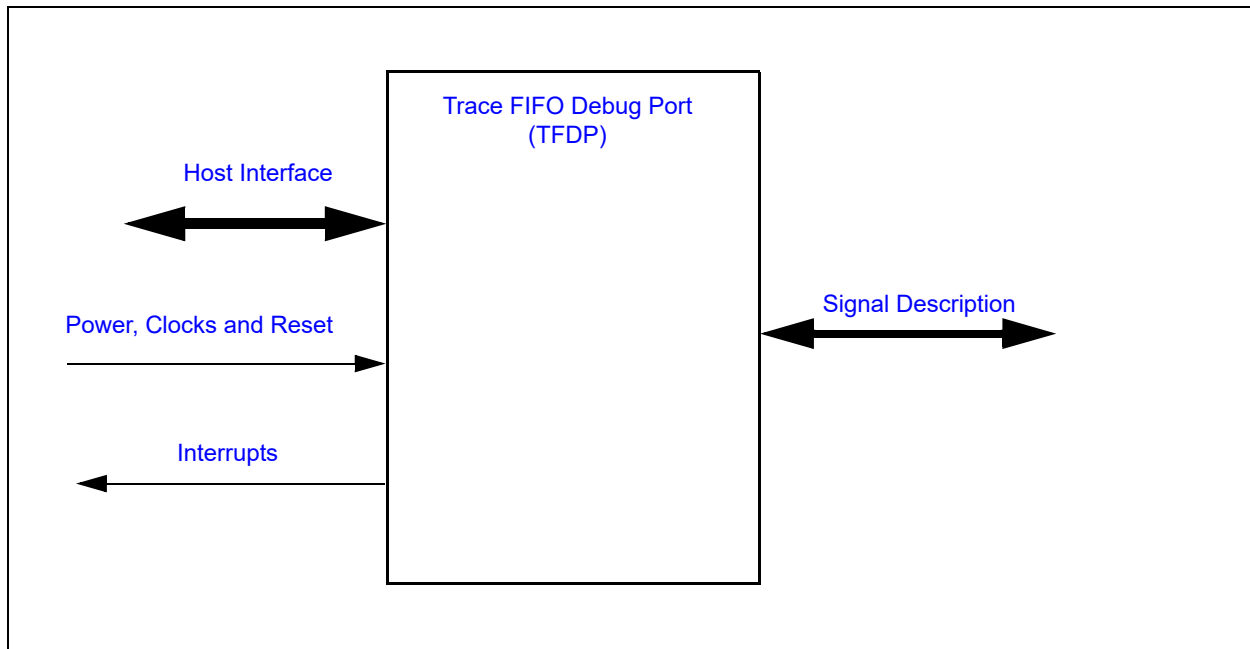

42.4 Signal Description

The Signal Description Table lists the signals that are typically routed to the pin interface.

TABLE 42-1: SIGNAL DESCRIPTION

Name	Direction	Description
TFDP Clk	Output	Derived from EC Bus Clock.
TFDP Data	Output	Serialized data shifted out by TFDP Clk .

42.5 Host Interface

The registers defined for the [Trace FIFO Debug Port \(TFDP\)](#) are accessible by the various hosts as indicated in [Section 3.2, "Block Overview and Base Addresses"](#).

42.6 Power, Clocks and Reset

This section defines the Power, Clock, and Reset parameters of the block.

42.6.1 POWER DOMAINS

Name	Description
VTR_CORE	The logic and registers implemented in this block are powered by this power well.

42.6.2 CLOCK INPUTS

Name	Description
48MHz	This is the main system clock.

42.6.3 RESETS

Name	Description
RESET_SYS	This signal resets all the registers and logic in this block to their default state.

42.7 Interrupts

There are no interrupts generated from this block.

42.8 Low Power Modes

The [Trace FIFO Debug Port \(TFDP\)](#) may be put into a low power state by the chip's Power, Clocks, and Reset (PCR) circuitry.

42.9 Description

The TFDP is a unidirectional (from processor to external world) two-wire serial, byte-oriented debug interface for use by processor firmware to transmit diagnostic information.

The TFDP consists of the [Debug Data Register](#), [Debug Control Register](#), a Parallel-to-Serial Converter, a Clock/Control Interface and a two-pin external interface ([TFDP Clk](#), [TFDP Data](#)). See [Figure 42-2](#).

FIGURE 42-2: BLOCK DIAGRAM OF TFDP DEBUG PORT

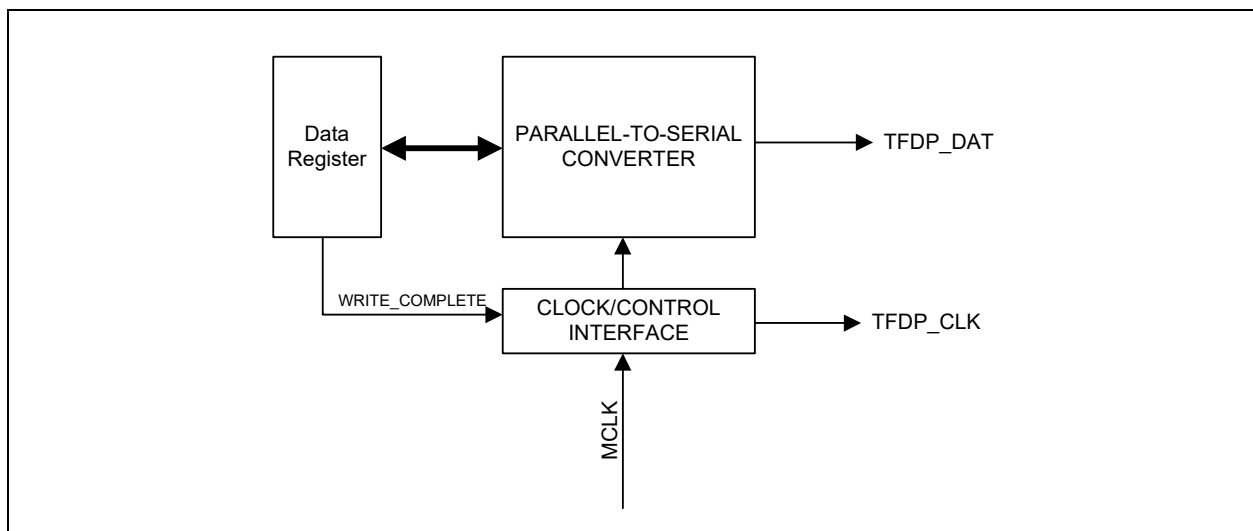

MEC1725

The firmware executing on the embedded controller writes to the [Debug Data Register](#) to initiate a transfer cycle ([Figure 42-2](#)). The [Debug Data Register](#) is loaded into a shift register and shifted out on TFDP_DAT LSB first at the programmed TFDP_CLK Clock rate ([Figure 42-3](#)).

Data is transferred in one direction only from the [Debug Data Register](#) to the external interface. The data is shifted out at the clock edge. The clock edge is selected by the [EDGE_SEL](#) bit in the [Debug Control Register](#). After being shifted out, valid data will be presented at the opposite edge of the TFDP_CLK. For example, when the [EDGE_SEL](#) bit is '0' (default), valid data will be presented on the falling edge of the TFDP_CLK. The Setup Time (to the falling edge of TFDP_CLK) is 10 ns, minimum. The Hold Time is 1 ns, minimum.

When the Serial Debug Port is inactive, the TFDP_CLK and TFDP_DAT outputs are '1.' The EC Bus Clock clock input is the transfer clock.

FIGURE 42-3: DATA TRANSFER

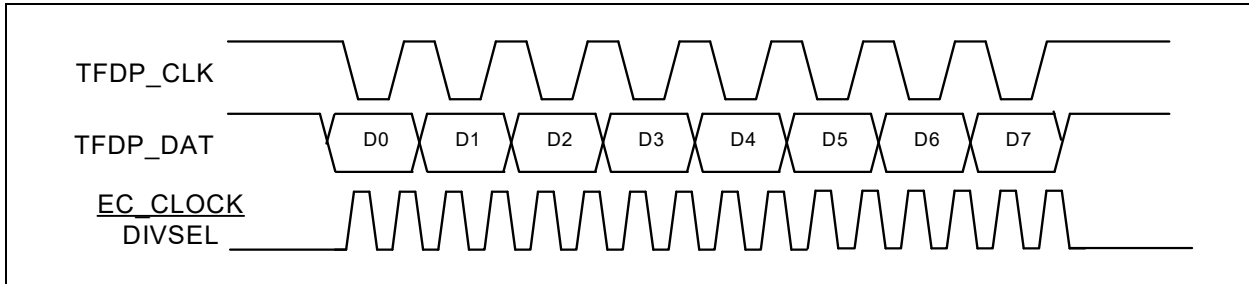

42.10 EC-Only Registers

Registers for this block are shown in the following summary table. Addresses for each register are determined by adding the offset to the Base Address for the [Trace FIFO Debug Port \(TFDP\)](#) Block in the Block Overview and Base Address Table in [Section 3.0, "Device Inventory"](#).

TABLE 42-2: REGISTER SUMMARY

Offset	Register Name
00h	Debug Data Register
04h	Debug Control Register

42.10.1 DEBUG DATA REGISTER

The Debug Data Register is Read/Write. It always returns the last data written by the TFDP or the power-on default '00h'.

Offset	00h			
Bits	Description	Type	Default	Reset Event
7:0	DATA Debug data to be shifted out on the TFDP Debug port. While data is being shifted out, the Host Interface will 'hold-off' additional writes to the data register until the transfer is complete.	R/W	00h	RESET_SYS

42.10.2 DEBUG CONTROL REGISTER

Offset	04h			
Bits	Description	Type	Default	Reset Event
7	Reserved	RES	-	-
6:4	IP_DELAY Inter-packet Delay. The delay is in terms of TFDP Debug output clocks. A value of 0 provides a 1 clock inter-packet period, while a value of 7 provides 8 clocks between packets:	R/W	000b	RESET_SYS
3:2	DIVSEL Clock Divider Select. The TFDP Debug output clock is determined by this field, according to Table 42-3, "TFDP Debug Clocking" :	R/W	00b	RESET_SYS
1	EDGE_SEL 1=Data is shifted out on the falling edge of the debug clock 0=Data is shifted out on the rising edge of the debug clock (Default)	R/W	0b	RESET_SYS
0	EN Enable. 1=Clock enabled 0=Clock is disabled (Default)	R/W	0b	RESET_SYS

TABLE 42-3: TFDP DEBUG CLOCKING

divsel	TFDP Debug Clock
00	24 MHz
01	12 MHz
10	6 MHz
11	Reserved

43.0 PORT 80 32-BIT BIOS DEBUG PORT

43.1 Overview

The [Port 80 32-Bit BIOS Debug Port](#) emulates the functionality of the “Port 80” legacy ISA plug-in card, expanded to the capability of collecting Debug Codes (POST Codes) as wide as 32 bits.

Debug codes may be written as Bytes, Words or DWords by the [Host Interface](#) to the [Port 80 32-Bit BIOS Debug Port](#), which occupies 4 contiguous byte addresses in the Host I/O address space, typically starting at 80h. In addition, a single non-contiguous 1-byte I/O location is provided, which may be designated as an alias to a selected byte within this 4-byte space for legacy 16-bit usage by the BIOS (ex. 80h/90h).

Data is collected in parallel, independently, into two locations:

- A FIFO for history and event-driven reporting by firmware
- A 32-bit Snapshot register, which shows the current contents last written by the Host chipset in all byte positions (that is, an idealized 32-bit image). It is captured before recording into the FIFO, so it is missing history but is immune to any loss from FIFO data overruns.

The [Port 80 32-Bit BIOS Debug Port](#) generates a FIFO Threshold interrupt to the EC, with a programmable set of useful threshold levels. The threshold level may be dynamically changed as needed. The Interrupt Pending status is identical to the threshold status of the FIFO (the THRES_STAT bit), though there is an Interrupt Enable bit that can be used to gate it. Acknowledging the interrupt requires changing the FIFO status: by reading enough data to return below the threshold, or changing the threshold level setting, or flushing the FIFO. There is no interrupt associated with the Snapshot Register itself.

FIFO and Snapshot status are preserved unaffected from Vcc Reset events (PLTRST#), and may be inspected by EC firmware or other diagnostic tools even after a chipset Global Reset event. The reset of the block is triggered by an explicit action from EC firmware (using the SOFT_RESET bit) or by the full chip-level reset.

43.2 References

There are no document references for this block.

43.3 Interface

This block is designed to be accessed internally via a registered host interface.

FIGURE 43-1: I/O DIAGRAM OF BLOCK

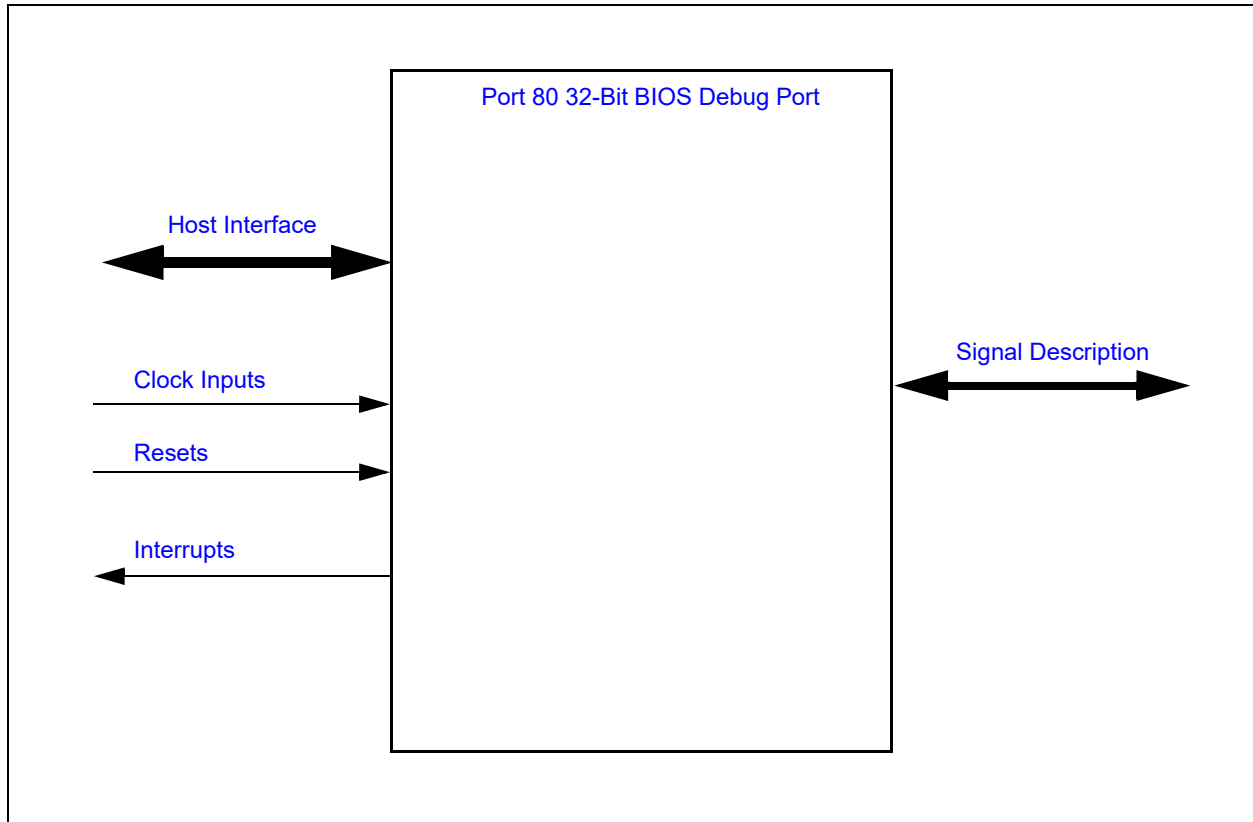

43.4 Signal Description

There are no external signals for this block.

43.5 Host Interface

The register set for the Port 80 block is accessed by the various hosts as indicated in [Section 3.2, "Block Overview and Base Addresses"](#).

43.6 Power, Clocks and Reset

This section defines the Power, Clock, and Reset parameters of the block.

43.6.1 POWER DOMAINS

Name	Description
VTR_CORE	This Power Well is used to power the registers and logic in this block.

43.6.2 CLOCK INPUTS

Name	Description
48MHz	This is the clock source for Port 80 block logic.

MEC1725

43.6.3 RESETS

Name	Description
RESET_SYS	Reset System. This signal resets all the registers and logic in this block to their default state. It is connected to the chip-wide reset, and is not triggered by Vcc level (PLTRST#) reset events. These events must be presented by firmware as the RESET_P80 event instead.
RESET_P80	Reset Port 80 Block. This is a local reset of this block. It is triggered by writing '1' to the SOFT_RESET bit in the Configuration Register . It is also triggered by the RESET_SYS event. Unlike previous generations of this block (8-bit), the ACTIVATE bits no longer trigger a FIFO flush, requiring this reset be used instead.

43.7 Interrupts

This section defines the Interrupt Sources generated from this block.

Source	Description
BDP_INT	The Port 80 BIOS Debug Port generates an EC interrupt when the amount of data in the Port 80 FIFO equals or exceeds the FIFO Threshold defined in the Configuration Register . The THRES_IEN bit in the Status Register , and the ACTIVATE bit for the Port 80 Base Logical Device must also be set to '1' in order to pass interrupts. The ACTIVATE bit for the Alias Logical Device has no effect.

43.8 Low Power Modes

The Port 80 block may be put into a low power state by the chip's Power, Clocks, and Reset (PCR) circuitry.

43.9 Description

See [Figure 43-2](#) for an overview of the block structure.

Note especially that the EC Interface and Host Interface share the same internal bus, and so Host and EC accesses are interleaved and cannot occur simultaneously. This means that race conditions cannot occur, whether they involve the simultaneous sampling of FIFO status with data, or dynamic reconfiguration such as changing the interrupt threshold. Wait states are imposed as necessary in order to ensure that internal operations remain interlocked with bus activity.

FIGURE 43-2: PORT 80 BLOCK DIAGRAM

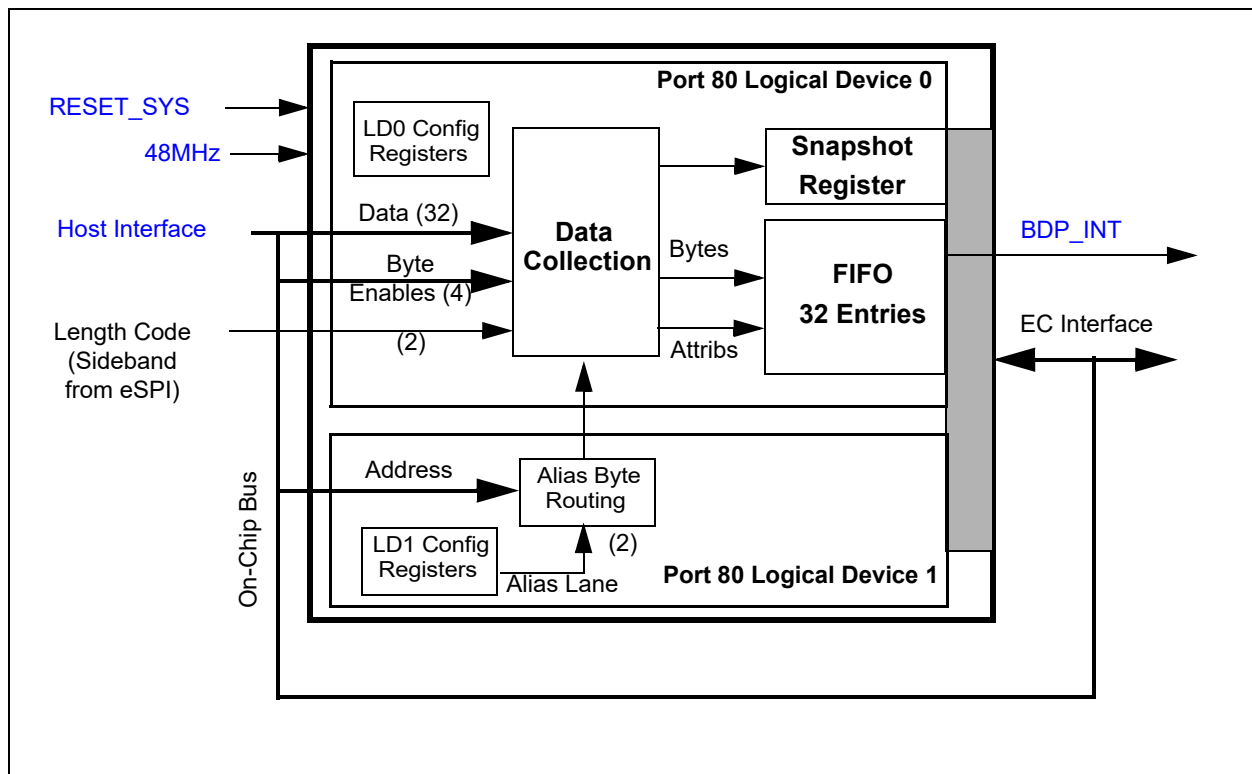

The [Port 80 32-Bit BIOS Debug Port](#) consists of a 32-entry FIFO accepting bytes from the Host. Host and EC access to the Port 80 block is through a set of registers. The Host can write the FIFO via the [Runtime Registers](#) and the EC can read the FIFO via the [EC Data Value Register](#). Plug and Play Configuration registers are also provided, organized as two Logical Devices (Port 80 Logical Devices LD0 and LD1), both part of this same block instance.

Writes to the [Host Data Register](#) (directly or via the [Host Alias Data Register](#) location) are captured from Byte, Word or DWord I/O instructions from the Host CPU, and are recorded and written to the FIFO as individual bytes with 4 bits of attribute information: Byte Lane (the two LSBs of its address) and a 2-bit Length field marking the beginning of a multi-byte I/O Write. Reads of the [Host Data Register](#) return zero.

Only the EC can read data from the FIFO, using the [EC Data Value Register](#). The use of this data is determined by EC Firmware alone. If writes to the [Host Data Register](#) overrun the FIFO, the oldest entry (next to be read) is discarded and OVERRUN status is posted. The OVERRUN bit and other FIFO status bits are visible with the Interrupt Enable in the 16-bit contiguous combination of the [Status Register](#) and [Interrupt Enable Register](#) for polling purposes, and are also available in the [EC Data Attributes Register](#) to be read simultaneously with the FIFO accesses for accurate recording.

In addition to the FIFO, a 32-bit Snapshot register immediately accepts bytes into their fields of the Debug Code, thereby providing the most recent 32-bit image. It may be read by EC Firmware at any time. Updates to this register occur one Host CPU instruction at a time, so that 16-bit or 32-bit updates occur atomically as seen by the Firmware. This register is immune to FIFO overrun, so it can serve as a backup to the FIFO sequences.

43.10 FIFO Structure

The FIFO is a “Fall-Through” structure. That is, writing into the FIFO unconditionally advances it, regardless of whether it is already full. Overrun events then have the effect of simultaneously writing the FIFO at one end while discarding the oldest entry (at the Reading end). The **OVERRUN** status bit is set and held until the oldest surviving Value byte is read by EC firmware, and indicates that one or more bytes BEFORE that one have been lost. Since the FIFO is no longer full after the Value is read, the **OVERRUN** status is then cleared automatically until another Overrun event occurs.

Reading from an empty FIFO does not exercise it, and is harmless, but returns an undefined Value. The **NOT_EMPTY** bit in the Attributes Register (which may be read together with the Value byte) is ‘0’ to flag when this has happened.

43.11 Port 80 Logical Device 0 (Base) Configuration Registers

Configuration Registers for the Base Logical Device of the [Port 80 32-Bit BIOS Debug Port](#) are listed in the following table. Host access to Configuration Registers is through the Configuration Port using the assigned Logical Device Number of this Logical Device and the Index shown in the “Host Index” column of the table. The EC can access Configuration Registers directly, using an address formed by adding the Base Address for this Logical Device shown in the Block Overview and Base Address Table in [Section 3.0, “Device Inventory”](#) to the offset shown in the “EC Offset” column.

TABLE 43-1: CONFIGURATION REGISTER SUMMARY, PORT 80 LD 0

EC Offset	Host Index	Register Name
330h	30h	Activate Register, Port 80 LD 0

43.11.1 ACTIVATE REGISTER, PORT 80 LD 0

Offset	330h			
Bits	Description	Type	Default	Reset Event
7:1	Reserved	RES	-	-
0	<p>ACTIVATE</p> <p>When this bit is asserted ‘1’, the block is enabled. When this bit is ‘0’, writes by the Host interface to the Host Data Register are silently ignored.</p> <p>This bit behaves differently from previous (8-bit) Port 80 implementations. The FIFO contents and status are not affected by the state of ACTIVATE, control bits in the Port 80 Configuration Register are not affected, nor is the Snapshot Register affected. Instead, the SOFT_RESET bit is used for this</p> <p>Note that SOFT_RESET resets this bit also.</p>	R/W	0h	RESET_P80

43.12 Port 80 Logical Device 1 (Alias) Configuration Registers

Configuration Registers for the Alias Logical Device of the [Port 80 32-Bit BIOS Debug Port](#) are listed in the following table. Host access to Configuration Registers is through the Configuration Port using the assigned Logical Device Number of this Logical Device and the Index shown in the “Host Index” column of the table. The EC can access Configuration Registers directly. The EC address for each register is formed by adding the Base Address for the assigned Logical Device Number of this Logical Device shown in the Block Overview and Base Address Table in [Section 3.0, “Device Inventory”](#) to the offset shown in the “EC Offset” column.

For the Alias function to work, it is necessary for the Activate bit in its own [Activate Register, Port 80 LD 1](#) to be set to '1', along with the Base ACTIVATE bit in the [Activate Register, Port 80 LD 1](#) otherwise no Alias Byte address will be available.

However, regardless of this bit, the 4 bytes of the Port 80 Base Logical Device (0) will remain accessible at their own Base Address, regulated by only its own ACTIVATE bit.

If the Alias feature is to be used, it is also necessary for the desired Byte Lane to be programmed in the [Alias Byte Lane Register](#). This 2-bit value determines which byte of the [Host Data Register](#) will receive the values written at this alias address.

TABLE 43-2: CONFIGURATION REGISTER SUMMARY, PORT 80 LD 1

EC Offset	Host Index	Register Name
330h	30h	Activate Register, Port 80 LD 1
3F0h	F0h	Alias Byte Lane Register

43.12.1 ACTIVATE REGISTER, PORT 80 LD 1

Offset	330h			
Bits	Description	Type	Default	Reset Event
7:1	Reserved	RES	-	-
0	<p>ACTIVATE</p> <p>When this bit is asserted '1', the Alias function is enabled. When this bit is '0', writes by the Host interface to the Host Alias Data Register are silently ignored.</p> <p>Note that SOFT_RESET resets this bit also.</p>	R/W	0h	RESET_P80

43.12.2 ALIAS BYTE LANE REGISTER

Offset	3F0h			
Bits	Description	Type	Default	Reset Event
7:2	Reserved	RES	-	-
1:0	<p>LANE</p> <p>This 2-bit number indicates which of the 4 bytes of the Port 80 Base Logical Device will receive a byte written to the Alias Data Register location.</p> <p>00 = Byte 0 (LSB) 01 = Byte 1 10 = Byte 2 11 = Byte 3 (MSB)</p>	R/W	0h	RESET_P80

MEC1725

43.13 Runtime Registers

The registers listed in the Runtime Register Summary tables are for the single instance of the [Port 80 32-Bit BIOS Debug Port](#). Because there are two Logical Devices, there are also two independent Base Address Registers allocated for it at the chip level: P80BAR0 (for Port 80 Logical Device 0) and P80BAR1 (for Port 80 Logical Device 1).

P80BAR0 designates a 4-byte aligned location which may be accessed either 1, 2 or 4 bytes wide. The width is fixed at 4 bytes.

P80BAR1 designates a single byte. The width is fixed at 1 byte.

Host access for each register listed in this table is defined by its associated Base Address Register.

The [Host Data Register](#), which may be accessed 1 to 4 bytes wide, is located at an offset of 0 relative to the P80BAR0 register. Traditionally this would be placed at I/O address 80h, occupying addresses 80h through 83h, but it may be assigned elsewhere.

The [Host Alias Data Register](#) is a single-byte portal, providing an alternate access address for a single byte of the Host Data Register. For example, a byte at Host I/O address 90h may be declared with the P80BAR1 register, mapping it so that it writes into Byte 1 of the [Host Data Register](#). In effect, then, that byte would be accessible using either of the two I/O addresses 81h or 90h.

See the Block Overview and Base Address Table in [Section 3.0, "Device Inventory"](#) for the locations of the BAR registers.

Note: Access to these Runtime registers may require setup in the Host Chipset as well. By default, an Intel Chipset will route all Byte, Word and DWORD accesses that are written exactly to I/O Port 80h, but may not pass values that are written to other addresses within this 4-byte range. It is recommended that a Generic I/O range be set up in the Chipset if it is desired to allow accesses to random byte locations.

TABLE 43-3: RUNTIME REGISTER SUMMARY, PORT 80 LOGICAL DEVICE 0 (BASE)

Offset	Base	Register Name
00h	P80BAR0	Host Data Register

43.13.1 HOST DATA REGISTER

Offset	00h from P80BAR0			
Bits	Description	Type	Default	Reset Event
31:24	HOST_DATA_BYTE3	W	0h	RESET_P80
23:16	HOST_DATA_BYTE2	W	0h	RESET_P80
15:8	HOST_DATA_BYTE1	W	0h	RESET_P80
7:0	HOST_DATA_BYTE0	W	0h	RESET_P80

TABLE 43-4: RUNTIME REGISTER SUMMARY, PORT 80 LOGICAL DEVICE 1 (ALIAS)

Offset	Base	Register Name
00h	P80BAR1	Host Alias Data Register

43.13.2 HOST ALIAS DATA REGISTER

Offset	00h from P80BAR1			
Bits	Description	Type	Default	Reset Event
7:0	HOST_ALIAS_DATA	W	0h	RESET_P80

The [Host Alias Data Register](#) must be written by the Host CPU only as a single byte. Writing to it as a larger value will record only the least-significant byte of the value.

43.14 EC-Only Registers

Registers for this block are all present in the Base component (Logical Device 0) shown in the following summary table. Addresses for each register are determined by adding the offset to the Base Address for the instance of the [Port 80 32-Bit BIOS Debug Port](#) Block in the Block Overview and Base Address Table in [Section 3.0, "Device Inventory"](#). Registers named TEST below are not to be used in normal operation, and will cause undefined operation if written.

TABLE 43-5: EC REGISTER SUMMARY

Offset	Register Name
100h	EC Data Value Register
101h	EC Data Attributes Register
104h	Configuration Register
108h	Status Register
109h	Interrupt Enable Register
10Ch	Snapshot Register
110h	TEST
114h	TEST

MEC1725

43.14.1 EC DATA VALUE REGISTER

Reading from this register byte accepts the value at the top of the FIFO, then advances the FIFO, updating both this location and the [EC Data Attributes Register](#). Best results are obtained by reading both registers together (below).

Offset	100h			
Bits	Description	Type	Default	Reset Event
7:0	<p>EC_VALUE</p> <p>Oldest FIFO byte from the Host. A multi-byte value is presented LS byte first, progressing to the more significant bytes.</p> <p>Reading from this register advances the FIFO, and immediately afterward reloads both this register and the EC Data Attributes Register from the FIFO. Other bits in the EC Data Attributes Register and Status Register are updated at the same time from the resulting FIFO status.</p> <p>If this register is read while the FIFO is empty, the FIFO is not advanced, and the value read from this register is undefined.</p>	R	0h	RESET_P80

43.14.2 EC DATA ATTRIBUTES REGISTER

Reading this one-byte register by itself does not exercise the FIFO. However, reading both this register and the [EC Data Value Register](#) together, as a 16-bit value, captures this information at the same instant as the FIFO data, and updates occur afterward by any updates from exercising the FIFO. There is no race condition possible between the two bytes when used this way, and this register then reflects the FIFO status immediately before the Read (esp. OVERRUN).

Offset	101h			
Bits	Description	Type	Default	Reset Event
7	Reserved	RES	-	-
6	THRES_STAT Threshold Status: 0 = The number of FIFO entries is below the selected Threshold. 1 = The number of FIFO entries is at or above the Threshold. This is an exact image of the bit by the same name in the Status Register .	R	0	RESET_P80
5	OVERRUN The OVERRUN bit is '1' when the host writes the Host Data Register when the FIFO is full. It is cleared by advancing the FIFO beyond the point of the overrun. This is an exact image of the bit by the same name in the Status Register .	R	0	RESET_P80
4	NOT_EMPTY The NOT_EMPTY bit is '1' when there is data in the FIFO. The NOT_EMPTY bit is '0' when the FIFO is empty. This is an exact image of the bit by the same name in the Status Register .	R	0	RESET_P80
3:2	EC_LENGTH See also Section 43.14.2.1, "Special Considerations for the EC_LENGTH Field," on page 617. 00 = One byte, or a continuation of a multi-byte value. 01 = The first byte (LSB) of a two-byte value. 10 = The first byte (LSB) of a 4-byte value. 11 = "Invalid": This is an "orphan" byte from a multi-byte value that was partially lost because of a previous overrun. This code suggests that it may be desirable to discard this byte.	R	0h	RESET_P80
1:0	EC_LANE The byte address to which this byte was written: 00 = Byte Lane 0 01 = Byte Lane 1 10 = Byte Lane 2 11 = Byte Lane 3	R	0h	RESET_P80

43.14.2.1 Special Considerations for the EC_LENGTH Field

The EC_LENGTH field is an attribute coming from the eSPI Host Interface only. If another Host Interface is in use, this field will never flag incoming bytes with a multi-byte code.

The EC_LENGTH field declares the width of an I/O Write performed by the Host CPU, as seen by the eSPI I/O traffic. If the value was not aligned to be fully contained within the 4-byte window of this block's [Host Data Register](#), some of these bytes may have been lost. Firmware should use the EC_LANE field also, on any FIFO entry declaring

MEC1725

EC_LENGTH = 01 or 10, to determine how many of the bytes are actually captured within the FIFO. See [Table 43-6, "Interpretation of Attribute Fields," on page 619](#) for a full itemization, but be aware that not all these cases will happen in the system.

This depends on the Chipset's own handling of misaligned I/O instructions. The EC_LENGTH is only known to be valid, matching the I/O instruction used by the Host (Byte/Word/DWord) for the following cases:

- A 1-byte Write to any byte offset: EC_LENGTH = 00
- A 2-byte (Word) Write to offset 0, 1 or 2: EC_LENGTH = 01
- A 4-byte (DWord) Write to offset 0 only: EC_LENGTH = 10

If bytes are lost due to a misaligned access, an Unsuccessful Completion event (IOCHK/SERR/NMI) can also be expected to occur in the Chipset if enabled. Any valid bytes received within the 4-byte window are transferred first.

If the EC_LENGTH field is showing a valid multi-byte size (01 or 10), and the FIFO becomes empty after reading the first byte with this attribute, the subsequent bytes have already been received and will be presented very shortly in the FIFO. It is recommended to wait for this to happen, while polling the NOT_EMPTY bit, since any delay is only due to bus availability within the device.

Any value written through the [Host Alias Data Register](#) will appear as a single byte, with an EC_LENGTH code of 00, regardless of the width written by the Host.

TABLE 43-6: INTERPRETATION OF ATTRIBUTE FIELDS

EC_LANE	EC_LENGTH	Overrun	Interpretation
00	00	0	Single byte at Byte Lane 0: ex. 80h
01	00	0	Single byte at Byte Lane 1: ex. 81h or alias BAR (typ 90h/etc) May be continuation of a multi-byte value begun earlier.
10	00	0	Single byte at Byte Lane 2: ex. 82h or alias BAR May be continuation of a multi-byte value begun earlier.
11	00	0	Single byte at Byte Lane 3: ex. 83h or alias BAR May be continuation of a multi-byte value begun earlier.
00	01	0	First of 2 bytes starting at Byte Lane 0
01	01	0	First of 2 bytes starting at Byte Lane 1 (Misaligned, but fully captured.)
10	01	0	First of 2 bytes starting at Byte Lane 2
11	01	0	Single byte at Byte Lane 3 (Misaligned, with loss of upper byte.)
00	10	0	First of 4 bytes starting at Byte Lane 0
01	10	0	First of 3 bytes starting at Byte Lane 1 (Misaligned, with loss of upper byte of 4.)
10	10	0	First of 2 bytes starting at Byte Lane 2 (Misaligned, with loss of upper 2 bytes of 4.)
11	10	0	Single byte at Byte Lane 3 (Misaligned, with loss of upper 3 bytes of 4.)
xx	00	1	Flags that this is a new 1-byte value after overrun. Firmware should discard any multi-byte value being collected and start over.
xx	01	1	Flags that this is a new 2-byte value after overrun. (Subject to adjustment as above for lost bytes due to alignment.) Firmware should discard any multi-byte value being collected and start over.
xx	10	1	Flags that this is a new 4-byte value after overrun. (Subject to adjustment as above for lost bytes due to alignment.) Firmware should discard any multi-byte value being collected and start over.
xx	11	x	Invalid byte: Flags that a multi-byte value was partially lost from the FIFO due to an overrun in the middle. Firmware should discard this byte.

MEC1725

43.14.3 CONFIGURATION REGISTER

Offset	104h			
Bits	Description	Type	Default	Reset Event
31	SOFT_RESET This bit provides the block-level Reset (RESET_P80). Writing '1' to this bit is necessary before beginning a new BIOS POST sequence, unless a full chip-level RESET_SYS event has been received. Neither this bit nor any other part of this block is affected directly by the Vcc-level PLTRST# reset event. Unlike previous (8-bit) generations of this block, neither of the ACTIVATE bits perform any logic re-initialization, leaving it to this bit instead. The ACTIVATE bits themselves are cleared by this bit.	W	0	RESET_SYS
30:11	Reserved	RES	-	-
10:8	FIFO_THRESHOLD This field determines the threshold for the Port 80 32-Bit BIOS Debug Port Interrupts . 7 = 30 entry threshold 6 = 28 entry threshold 5 = 24 entry threshold 4 = 20 entry threshold 3 = 16 entry threshold 2 = 8 entry threshold 1 = 4 entry threshold 0 = 1 entry threshold	R/W	0h	RESET_P80
7:2	Reserved	RES	-	-
1	SNAPSHOT_CLR When this field is written with a '1', the Snapshot Register is reset to contain 0h. This bit does not affect the FIFO contents nor its state. Writes of a '0' to this field have no effect. Reads always return '0'. Writing '1' to the SOFT_RESET bit includes the same effect as writing '1' here.	W	0	RESET_SYS
0	FLUSH_FIFO When this field is written with a '1', the FIFO is made empty and any Overrun indication is also cleared. This bit does not affect the Snapshot Register . Any multi-byte value still being collected is also flushed, and will not be added into the FIFO afterward. Writes of a '0' to this field have no effect. Reads always return '0'. Writing '1' to the SOFT_RESET bit includes the same effect as writing '1' here.	W	0	RESET_SYS

43.14.4 STATUS REGISTER

Offset	108h			
Bits	Description	Type	Default	Reset Event
7:3	Reserved	RES	-	-
2	THRES_STAT Threshold Status. This is also the only Interrupt Pending bit for the block. Note that this bit is Read-Only, so that the FIFO state must be changed to clear it (by reading enough data to leave fewer bytes than the Threshold level, by changing the Threshold level itself, or flushing the FIFO). 0 = The number of FIFO entries is below the selected Threshold. 1 = The number of FIFO entries is at or above the Threshold.	R	0	RESET_P80
1	OVERRUN The OVERRUN bit is set to '1' when the host writes the Host Data Register if the FIFO is already full. It is cleared by making the FIFO no longer full; by reading the FIFO or flushing it.	R	0	RESET_P80
0	NOT_EMPTY The NOT_EMPTY bit is '1' when there is data in the FIFO. The NOT_EMPTY bit is '0' when the FIFO is empty.	R	0	RESET_P80

43.14.5 INTERRUPT ENABLE REGISTER

This register is placed at the next consecutive byte address after the [Status Register](#). Reading both this register and the [Status Register](#) together, as a 16-bit value, may be useful in interrupt polling.

Offset	109h			
Bits	Description	Type	Default	Reset Event
7:1	Reserved	RES	-	-
0	THRES_IEN 0 = Threshold Interrupt is disabled. (default) 1 = Threshold Interrupt is enabled, and asserted while the Status Register bit THRES_STAT is '1'.	R/W	0	RESET_P80

This register is placed immediately following the byte-wide [Status Register](#) for the sake of efficient and unambiguous polling using a 16-bit Read.

MEC1725

43.14.6 SNAPSHOT REGISTER

Offset	10Ch			
Bits	Description	Type	Default	Reset Event
31:0	<p>IMAGE</p> <p>Current image of the 4-byte Port 80 value, capturing values directly from the Host CPU. May be cleared to 0h by writing '1' to the SNAPSHOT_CLR bit.</p> <p>The FLUSH_FIFO bit has no effect on this register's function, and does not cause pending updates to be lost.</p>	R	0h	RESET_P80

This register collects multi-byte values as atomic updates to all the affected bytes in parallel. See [Section 43.14.2.1, "Special Considerations for the EC_LENGTH Field,"](#) on page 617 for the interpretation of multi-byte data.

44.0 VBAT-POWERED CONTROL INTERFACE

44.1 General Description

The [VBAT-Powered Control Interface](#) (VCI) has VBAT-powered combinational logic and input and output signal pins. The block interfaces with the [Real Time Clock](#) as well as the Week Alarm.

44.2 Interface

This block is designed to be accessed externally via the pin interface and internally via a registered host interface.

FIGURE 44-1: I/O DIAGRAM OF BLOCK

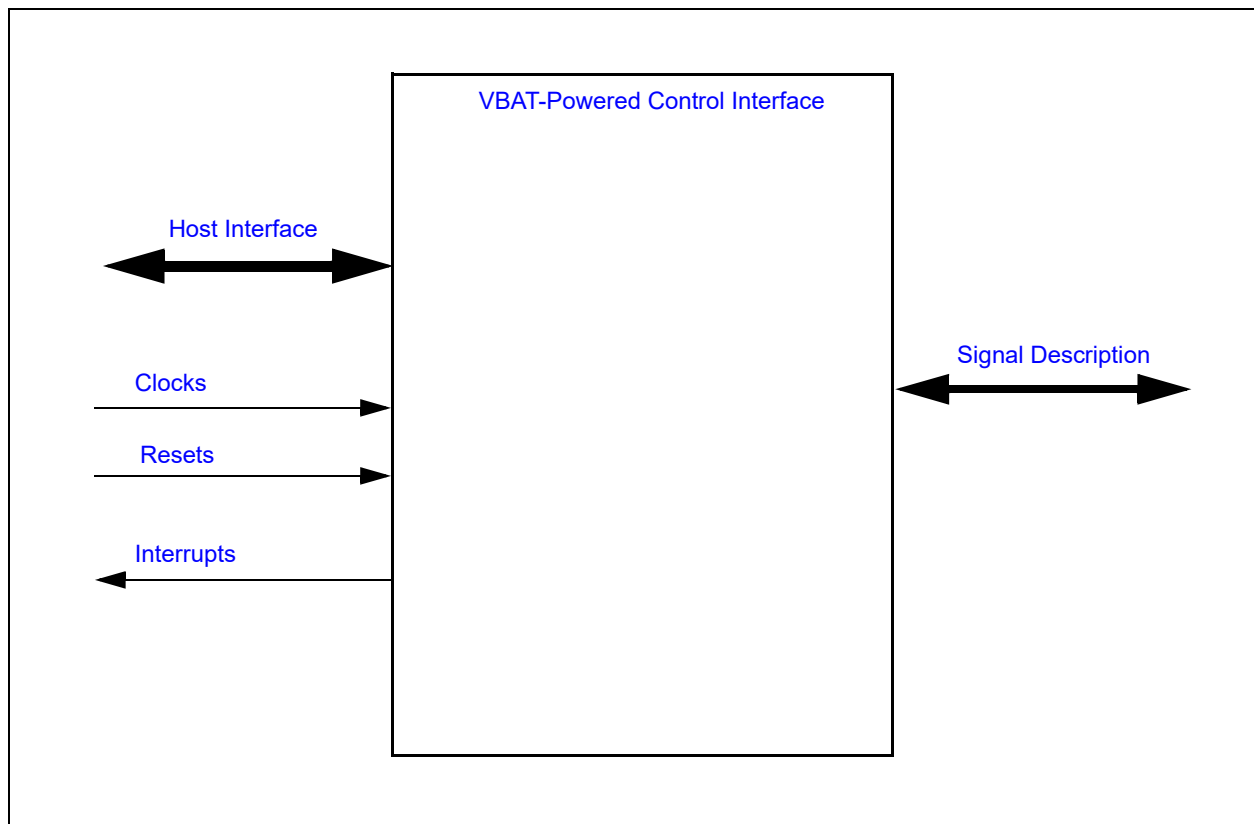

44.3 Signal Description

TABLE 44-1: EXTERNAL SIGNAL DESCRIPTION

Name	Direction	Description
VCI_INx	INPUT	Active-low inputs that can cause wakeup or interrupt events. Note 2
VCI_OVRD_IN	INPUT	Active high input that can cause wakeup or interrupt events.
VCI_OUT1	OUTPUT	Output status driven by this block. Note 1

Note 1: VCI_OUT1 is the same as the VCI_OUT mentioned throughout in this data sheet

2: The VCI IP supports up to seven VCI_IN inputs. These inputs are generically referred to as VCI_INx. Input signals not routed to pins or balls on the package are connected to [VBAT](#). Refer [Pin List](#) to find the number of VCI_IN pins in the chip

MEC1725

TABLE 44-2: INTERNAL SIGNAL DESCRIPTION

Name	Direction	Description
Week_Alarm	INPUT	Signal from the Week Timer block. The alarm is asserted by the timer when the Week_Alarm Power-Up Output is asserted
RTC_Alarm	INPUT	Signal from the Real Time Clock block. The alarm is asserted by the RTC when the RTC_ALRM signal is asserted.
VTR_PWRGD	INPUT	Status signal for the state of the VTR power rail. This signal is high if the power rail is on, and low if the power rail is off.

44.4 Host Interface

The registers defined for the [VBAT-Powered Control Interface](#) are accessible only by the EC.

44.5 Power, Clocks and Resets

This section defines the Power, Clock, and Reset parameters of the block.

44.5.1 POWER DOMAINS

Name	Description
VBAT	This power well sources all of the internal registers and logic in this block.
VTR_CORE	The power well sources register access by the host. The block continues to operate internally while this rail is down

44.5.2 CLOCKS

This block does not require clocks.

44.5.3 RESETS

Name	Description
RESET_VBAT	This reset signal is used reset all of the registers and logic in this block.
RESET_SYS	This reset signal is used to inhibit the bus communication logic, and isolates this block from VTR_CORE powered circuitry on-chip. Otherwise it has no effect on the internal state.

44.6 Interrupts

Source	Description
VCI_INx	These interrupts are routed to the Interrupt Aggregator. They are only asserted when both VBAT and VTR_CORE are powered. Edge detection and assertion level for the interrupt are configured in the GPIO Pin Control Registers for the GPIOs that shares pins with VCI_INx# inputs. The interrupts are equivalent to the GPIO interrupts for the GPIOs that share the pins, but appear on different registers in the Interrupt Aggregator. Note 2
VCI_OVRD_IN	This interrupt is routed to the Interrupt Aggregator. It is only asserted when both VBAT and VTR_CORE are powered.

44.7 Low Power Modes

The VBAT-powered Control Interface has no low-power modes. It runs continuously while the [VBAT](#) well is powered.

44.8 General Description

The [VBAT-Powered Control Interface](#) (VCI) is used to drive the VCI_OUT pin. The output pin can be controlled either by VBAT-powered inputs, or by firmware when the [VTR_CORE](#) is active and the EC is powered and running. When the VCI_OUT pin is controlled by hardware, either because [VTR_CORE](#) is inactive or because the VCI block is configured for hardware control, the VCI_OUT pin can be asserted by a number of inputs:

- When one or more of the VCI_INx# pins are asserted. By default, the VCI_INx# pins are active low, but firmware can switch each input individually to an active-high input. See [Section 44.8.1, "Input Polarity"](#).
- When the Week Alarm from the Week Alarm Interface is asserted
- When the RTC Alarm from the Real Time Clock is asserted

Firmware can configure which of the hardware pin inputs contribute to the VCI_OUT output by setting the enable bits in the [VCI Input Enable Register](#). Even if the input pins are not configured to affect VCI_OUT, firmware can monitor their current state through the status bits in the [VCI Register](#). Firmware can also enable EC interrupts from the state of the input pins.

Each of the VCI_INx# pins can be configured for additional properties.

- By default, each of the VCI_INx# pins have an input glitch filter. All glitch filters can be disabled by the [FILTERS_BYPASS](#) bit in the [VCI Register](#)
- Assertions of each of the VCI_INx# pins can optionally be latched, so hardware can maintain the assertion of a VCI_INx# even after the physical pin is de-asserted, or so that firmware can determine which of the VCI_INx# inputs contributed to VCI_OUT assertion. See the [Latch Enable Register](#) and the [Latch Resets Register](#).
- Rising edges and falling edges on the VCI_INx# pins are latched, so firmware can detect transitions on the VCI_INx# pins even if the transitions occurred while EC power was not available. See [Section 44.8.2, "Edge Event Status"](#).

If none of the additional properties are required, firmware can disable a VCI_INx# pin completely, by clearing both the corresponding bit in the [VCI Input Enable Register](#) and the corresponding bit in the [VCI Buffer Enable Register](#). When both bits are '0', the input is disabled and will not be a drain on the VBAT power rail.

When [VTR_CORE](#) power is present and the EC is operating, firmware can configure the VCI_OUT pin to operate as a general-purpose output pin. The VCI_OUT pin is firmware-controlled when the [FW_EXT](#) bit in the [VCI Register](#) is '1'. When firmware is controlling the output, the state of VCI_OUT is defined by the [VCI_FW_CNTRL](#) bit in the same register. When [VTR_CORE](#) is not present (the [VTR_PWRGD](#) input is low), the VCI_OUT pin is also determined by the hardware circuit.

The following figures illustrate the VBAT-Power Control Interface logic:

FIGURE 44-2: VCI_OUT BLOCK DIAGRAM

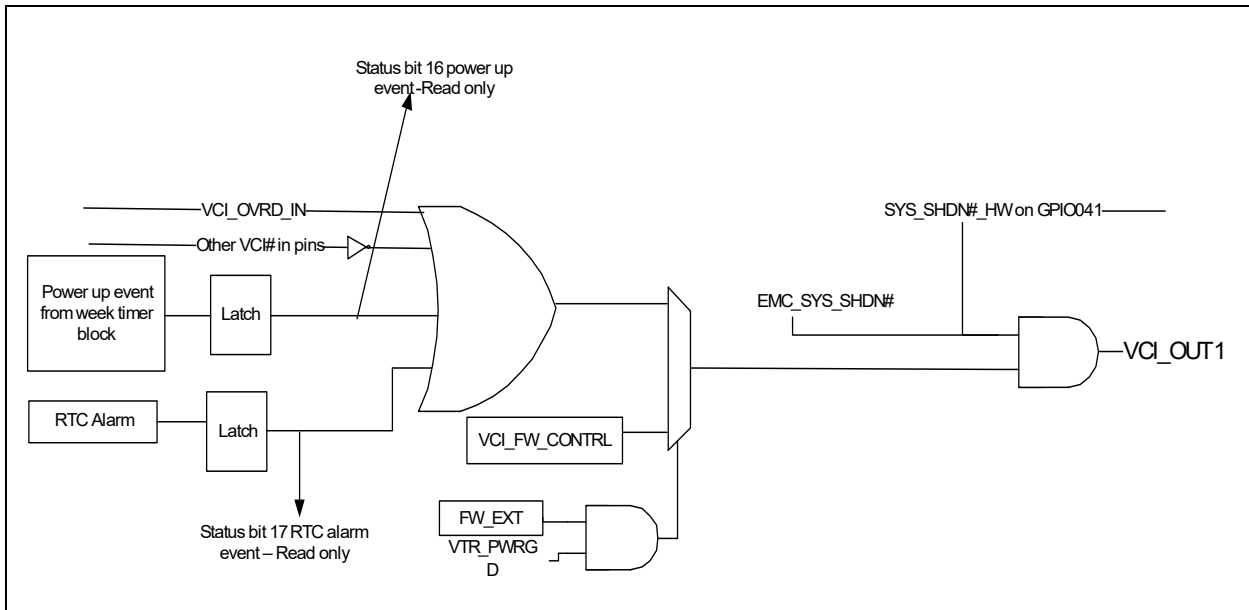

The VCI_INx# Logic in the block diagram is illustrated in the following figure:

FIGURE 44-3: VBAT-POWERED CONTROL INTERFACE BLOCK DIAGRAM

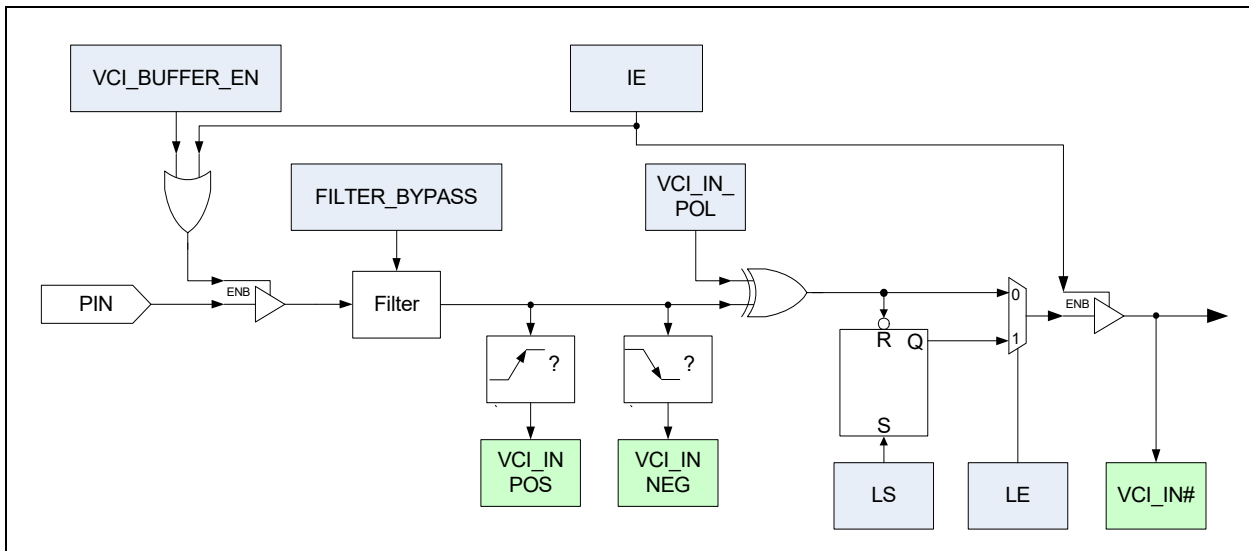

44.8.1 INPUT POLARITY

The VCI_INx# pins have an optional polarity inversion. The inversion takes place after any input filtering and before the VCI_INx# signals are latched in the VCI_INx# status bits in the VCI Register. Edge detection occurs before the polarity inversion. The inversion is controlled by battery-backed configuration bits in the [VCI Polarity Register](#).

44.8.2 EDGE EVENT STATUS

Each VCI_INx# input pin is associated with two register bits used to record edge transitions on the pins. The edge detection takes place after any input filtering, before polarity control and occurs even if the VCI_INx# input is not enabled as part of the VCI_OUT logic (the corresponding control bit in the [VCI Input Enable Register](#) is '0') or if the state of the

VCI_INx# input is not latched (the corresponding control bit in the [Latch Enable Register](#) is '0'). One bit is set whenever there is a high-to-low transition on the VCI_INx# pin (the [VCI Negedge Detect Register](#)) and the other bit is set whenever there is a low-to-high transition on the VCI_INx# pin (the [VCI Posedge Detect Register](#)).

In order to minimize power drain on the VBAT circuit, the edge detection logic operates only when the input buffer for a VCI_INx# pin is enabled. The input buffer is enabled either when the VCI_INx# pin is configured to determine the VCI_OUT pin, as controlled by the VCI_IN[1:0]# field of the [VCI Register](#), or when the input buffer is explicitly enabled in the [VCI Input Enable Register](#). When the pins are not enabled transitions on the pins are ignored.

The VCI_OVRD_IN input also has an Input Buffer Enable and an Input Enable bit associated with VCI_OUT. However, the VCI_OVRD_IN input does not have any filtering, latching, input edge detection or polarity control.

44.8.3 VCI PIN MULTIPLEXING

Each of the VCI inputs, as well as VCI_OUT, are multiplexed with standard [VTR_CORE](#)-powered GPIOs. When [VTR_CORE](#) power is off, the mux control is disabled and the pin always reverts to the VCI function. The VCI_INx# function should be disabled in the [VCI Input Enable Register](#) [VCI Buffer Enable Register](#) and for any pin that is intended to be used as a GPIO rather than a VCI_INx#, so that VCI_OUT is not affected by the state of the pin. The VCI_OVRD_IN function should similarly be disabled if the pin is to be used as a GPIO.

44.8.4 POWER ON INHIBIT TIMER

The Power On Inhibit Timer prevents the [VBAT-Powered Control Interface](#) VCI_OUT pin from being asserted for a programmable time period after the SYS_SHDN# pin asserted. This holdoff time can be used to give a system the opportunity to cool down after a thermal shutdown before allowing a user to attempt to turn the system on. While the Inhibit Timer is asserted, the VCI_OUT pin remains de-asserted and is unaffected by the VCI, Week Alarm and RTC interfaces.

The holdoff time is configured using the [Holdoff Count Register](#). By setting the [Holdoff Count Register](#) to 0 the Inhibit Timer is disabled. When disabled, the HOLDOFF# signal is de-asserted and no counting takes place.

The HOLDOFF# output is asserted within one 32.768KHz clock cycle from the time SYS_SHDN# is asserted.

The following figure illustrates the operation of the Inhibit Timer:

FIGURE 44-4: POWER ON INHIBIT TIMER

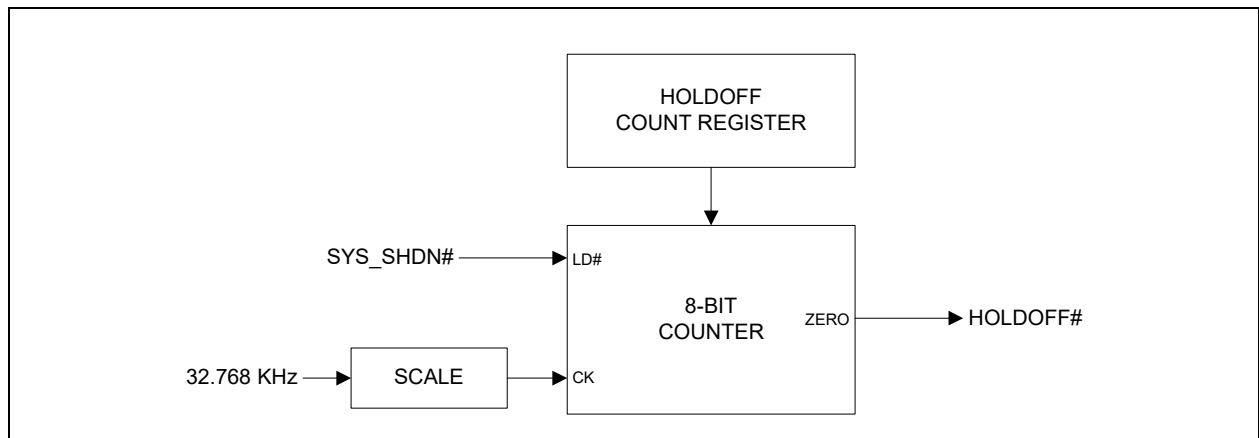

The SCALE function reduces the 32.768KHz clock to 8Hz, so that the 8-bit counter counts intervals of 125ms. The following table shows some of examples of the effect of several settings of the [Holdoff Count Register](#):

TABLE 44-3: HOLDOFF TIMING EXAMPLES

Holdoff Count Register	Holdoff Time (SEC)
0	Disabled (default)
1	0.125
5	0.625
10	1.25
15	1.875

MEC1725

TABLE 44-3: HOLDOFF TIMING EXAMPLES (CONTINUED)

Holdoff Count Register	Holdoff Time (SEC)
100	12.5
150	18.75
200	25
255	31.875

44.8.5 APPLICATION EXAMPLE

For this example, a mobile platform configures the VBAT-Powered Control Interface (VCI) as follows:

- VCI_IN0# is wired to a power button on the mobile platform
- VCI_IN1# is wired to a power button on a dock
- The VCI_OUT pin is connected to the regulator that sources the VTR power rail, the rail which powers the EC

The VCI can be used in a system as follows:

1. In the initial condition, there is no power on either the VTR or VBAT power rails. All registers in the VCI are in an indeterminate state
2. A coin cell battery is installed, causing a RESET_VBAT. All registers in the interface are forced to their default conditions. The VCI_OUT pin is driven by hardware, input filters on the VCI_INx# pins are enabled, the VCI_INx# pins are all active low, all VCI inputs are enabled and all edge and status latches are in their non-asserted state
3. The power button on VCI_IN0# is pushed. This causes VCI_OUT to be asserted, powering the VTR rail. This causes the EC to boot and start executing EC firmware
4. The EC changes the VCI configuration so that firmware controls the VCI_OUT pin, and sets the output control so that VCI_OUT is driven high. With this change, the power button can be released without removing the EC power rail.
5. EC firmware re-configures the VCI logic so that the VCI_INx# input latches are enabled. This means that subsequent presses of the power button do not have to be held until EC firmware switches the VCI logic to firmware control
6. During this phase the VCI_OUT pin is driven by the firmware-controlled state bit and the VCI input pins are ignored. However, the EC can monitor the state of the pins, or generate inputs when their state changes
7. At some later point, EC firmware must enter a long-term power-down state.
 - Firmware configures the Week Timer for a Week Alarm once every 8 hours. This will turn on the EC power rail three times a day and enable the EC to perform low frequency housekeeping tasks even in its lowest-power state
 - Firmware de-asserts VCI_OUT. This action kills power to the EC and automatically returns control of the VCI_OUT pin to hardware.
 - The EC will remain in its lowest-power state until a power pin is pushed, AC power is connected, or the Sub-Week Alarm is active

Note: If Embedded Reset functionality is used, then VCI_OUT needs to control Power Supply (to generate the Power On Reset). If VCI_OUT does not control the power, when Embedded reset functionality is enabled, there has to be an external Reset applied to the chip after the VCI_OUT is asserted to reset the chip.

44.9 EC Registers

Registers for this block are shown in the following summary table. Addresses for each register are determined by adding the offset to the Base Address for the VBAT-Powered Control Interface Block in the Block Overview and Base Address Table in Section 3.0, "Device Inventory".

TABLE 44-4: REGISTER SUMMARY

EC Offset	Register Name
00h	VCI Register
04h	Latch Enable Register
08h	Latch Resets Register

TABLE 44-4: REGISTER SUMMARY

EC Offset	Register Name
0Ch	VCI Input Enable Register
10h	Holdoff Count Register
14h	VCI Polarity Register
18h	VCI Posedge Detect Register
1Ch	VCI Negedge Detect Register
20h	VCI Buffer Enable Register

44.9.1 VCI REGISTER

Offset	00h			
Bits	Description	Type	Default	Reset Event
31:18	Reserved	RES	-	-
17	RTC_ALARM If enabled by RTC_ALARM_LE , this bit is set to '1' if the RTC Alarm signal is asserted. It is reset by writes to RTC_ALARM_LS .	R	0	RESET_VBAT
16	WEEK_ALARM If enabled by WEEK_ALARM_LE , this bit is set to '1' if the Week Alarm signal is asserted. It is reset by writes to WEEK_ALARM_LS .	R	0	RESET_VBAT
15:13	Reserved	RES	-	-
12	FILTERS_BYPASS The Filters Bypass bit is used to enable and disable the input filters on the VCI_INx# pins. See Section 47.17, "VBAT-Powered Control Interface Timing" . 1=Filters disabled 0=Filters enabled (default)	R/W	0	RESET_VBAT
11	FW_EXT This bit controls selecting between the external VBAT-Powered Control Interface inputs, or the VCI_FW_CNTRL bit output to control the VCI_OUT pin. 1=VCI_OUT is determined by the VCI_FW_CNTRL field, when VTR_CORE is active Note: 0=VCI_OUT is determined by the external inputs.	R/W	0	RESET_SYS and RESET_VBAT
<p>Note 1: The VCI_IN[6:0]# bits default to the state of their respective input pins. The VCI_OUT bit is determined by the VCI hardware circuit</p> <p>2: Refer Section 2.3, "Pin List" for the number of VCI_INx pins available in the chip</p>				

MEC1725

Offset	00h			
Bits	Description	Type	Default	Reset Event
10	<p>VCI_FW_CNTRL</p> <p>This bit can allow EC firmware to control the state of the VCI_OUT pin. For example, when VTR_PWRGD is asserted and the FW_EXT bit is '1', clearing the VCI_FW_CNTRL bit de-asserts the active high VCI_OUT pin.</p> <p>BIOS must set this bit to '1' prior to setting the FW_EXT bit to '1' on power up, in order to avoid glitches on the VCI_OUT pin.</p>	R/W	0	RESET_SYS and RESET_VBAT
9	<p>VCI_OUT</p> <p>This bit provides the current status of the VCI_OUT pin.</p>	R	See Note 1	–
6:0	<p>VCI_IN[6:0]#</p> <p>These bits provide the latched state of the associated VCI_INx# pin, if latching is enabled or the current state of the pin if latching is not enabled. In both cases, the value is determined after the action of the VCI Polarity Register.</p>	R	See Note 2	
<p>Note 1: The VCI_IN[6:0]# bits default to the state of their respective input pins. The VCI_OUT bit is determined by the VCI hardware circuit</p> <p>2: Refer Section 2.3, "Pin List" for the number of VCI_INx pins available in the chip</p>				

44.9.2 LATCH ENABLE REGISTER

Offset	04h			
Bits	Description	Type	Default	Reset Event
31:18	Reserved	RES	-	-
17	<p>RTC_ALARM_LE</p> <p>Latch enable for the RTC Power-Up signal.</p> <p>1=Enabled. Assertions of the RTC Alarm are held until the latch is reset by writing the corresponding LS[6:0] bit</p> <p>0=Not Enabled. The RTC Alarm signal is not latched but passed directly to the VCI_OUT logic</p>	R/W	0h	RESET_VBAT
16	<p>WEEK_ALARM_LE</p> <p>Latch enable for the Week Alarm Power-Up signal.</p> <p>1=Enabled. Assertions of the Week Alarm are held until the latch is reset by writing the corresponding LS[6:0] bit</p> <p>0=Not Enabled. The Week Alarm signal is not latched but passed directly to the VCI_OUT logic</p>	R/W	0h	RESET_VBAT

Offset	04h			
Bits	Description	Type	Default	Reset Event
15:7	Reserved	RES	-	-
6:0	<p>LE[6:0] Latching Enables. Latching occurs after the Polarity configuration, so a VCI_INx# pin is asserted when it is '0' if VCI_IN_POL[6:0] is '0', and asserted when it is '1' if VCI_IN_POL[6:0] is '1'.</p> <p>For each LE[x] bit in the field: 1=Enabled. Assertions of the VCI_INx# pin are held until the latch is reset by writing the corresponding LS[6:0] bit 0=Not Enabled. The VCI_INx# signal is not latched but passed directly to the VCI_OUT logic</p>	R/W	0h Note 2	RESET_VBAT

44.9.3 LATCH RESETS REGISTER

Offset	08h			
Bits	Description	Type	Default	Reset Event
31:18	Reserved	RES	-	-
17	<p>RTC_ALARM_LS RTC Alarm Latch Reset. When this bit is written with a '1', the RTC Alarm Event latch is reset</p> <p>The RTC Alarm input to the latch has priority over the Reset input</p> <p>Reads of this register are undefined.</p>	W	-	-
16	<p>WEEK_ALARM_LS Week Alarm Latch Reset. When this bit is written with a '1', the Week Alarm Event latch is reset</p> <p>The Week Alarm input to the latch has priority over the Reset input</p> <p>Reads of this register are undefined.</p>	W	-	-
15:7	Reserved	RES	-	-
6:0	<p>LS[6:0] Latch Resets. When a Latch Resets bit (LS[x]) is written with a '1', the corresponding VCI_INx# latch is de-asserted ('1').</p> <p>The VCI_INx# input to the latch has priority over the Latch Reset input, so firmware cannot reset the latch while the VCI_INx# pin is asserted. Firmware should sample the state of the pin in the VCI Register before attempting to reset the latch. As noted in the Latch Enable Register, the assertion level is determined by the VCI_IN_POL[6:0] bit.</p> <p>Reads of this register are undefined.</p>	W	- Note 2	-

MEC1725

44.9.4 VCI INPUT ENABLE REGISTER

Offset	0Ch			
Bits	Description	Type	Default	Reset Event
31:7	Reserved	RES	-	-
6:0	<p>IE[6:0] Input Enables for VCI_INx# signals.</p> <p>After changing the input enable for a VCI input, firmware should reset the input latch and clear any potential interrupt that may have been triggered by the input, as changing the enable may cause the internal status to change.</p> <p>For each IE[x] bit in the field: 1=Enabled. The corresponding VCI_INx# input is not gated and toggling the pin will affect the VCI_OUT pin 0=Not Enabled. The corresponding VCI_INx# input does not affect the VCI_OUT pin, even if the input is '0.' Unless the corresponding bit in the VCI Buffer Enable Register is 1, latches are not asserted, even if the VCI_INx# pin is low, during a VBAT power transition</p>	R/W	01h Note 2	RESET_VBAT

44.9.5 HOLDOFF COUNT REGISTER

Offset	10h			
Bits	Description	Type	Default	Reset Event
31:8	Reserved	RES	-	-
7:0	<p>HOLDOFF_TIME These bits determine the period of time the VCI_OUT logic is inhibited from re-asserting VCI_OUT after a SYS_SHDN# event.</p> <p>FFh-01h=The Power On Inhibit Holdoff Time is set to a period between 125ms and 31.875 seconds. See Table 44-3 for examples 0=The Power On Inhibit function is disabled</p>	RW	0	RESET_VBAT

44.9.6 VCI POLARITY REGISTER

Offset	14h			
Bits	Description	Type	Default	Reset Event
31:7	Reserved	RES	-	-
6:0	<p>VCI_IN_POL[6:0] These bits determine the polarity of the VCI_INx input signals:</p> <p>For each VCI_IN_POL[x] bit in the field: 1=Active High. The value on the pins is inverted before use 0=Active Low (default)</p>	RW	0 Note 2	RESET_VBAT

44.9.7 VCI POSEDGE DETECT REGISTER

Offset	18h			
Bits	Description	Type	Default	Reset Event
31:7	Reserved	RES	-	-
6:0	<p>VCI_IN_POS[6:0] These bits record a low to high transition on the VCI_INx# pins. A "1" indicates a transition occurred.</p> <p>For each VCI_IN_POS[x] bit in the field: 1=Positive Edge Detected 0=No edge detected</p>	R/WC	0 Note 2	RESET_VBAT

44.9.8 VCI NEGEDGE DETECT REGISTER

Offset	1Ch			
Bits	Description	Type	Default	Reset Event
31:7	Reserved	RES	-	-
6:0	<p>VCI_IN_NEG[6:0] These bits record a high to low transition on the VCI_INx# pins. A "1" indicates a transition occurred.</p> <p>For each VCI_IN_NEG[x] bit in the field: 1=Negative Edge Detected 0=No edge detected</p>	R/WC	0 Note 2	RESET_VBAT

MEC1725

44.9.9 VCI BUFFER ENABLE REGISTER

Offset	20h			
Bits	Description	Type	Default	Reset Event
31:7	Reserved	RES	-	-
6:0	<p>VCI_BUFFER_EN[6:0] Input Buffer enable.</p> <p>After changing the buffer enable for a VCI input, firmware should reset the input latch and clear any potential interrupt that may have been triggered by the input, as changing the buffer may cause the internal status to change.</p> <p>This register has no effect when VTR_CORE is powered. When VTR_CORE is on, the input buffers are enabled only by the IE[6:0] bit.</p> <p>For each VCI_BUFFER_EN[x] bit in the field: 1=VCI_INx# input buffer enabled independent of the IE[6:0] bit. The edge detection latches for this input are always enabled 0=VCI_INx# input buffer enabled by the IE[6:0] bit. The edge detection latches are only enabled when the IE[6:0] bit is '1' (default)</p>	RW	0 Note 2	RESET_VBAT

45.0 VBAT-POWERED RAM

45.1 Overview

The VBAT Powered RAM provides a 128 Byte Random Accessed Memory that is operational while the main power rail is operational, and will retain its values powered by battery power while the main rail is unpowered.

45.2 References

No references have been cited for this feature.

45.3 Terminology

There is no terminology defined for this section.

45.4 Interface

This block is designed to be accessed internally via a registered host interface.

FIGURE 45-1: I/O DIAGRAM OF BLOCK

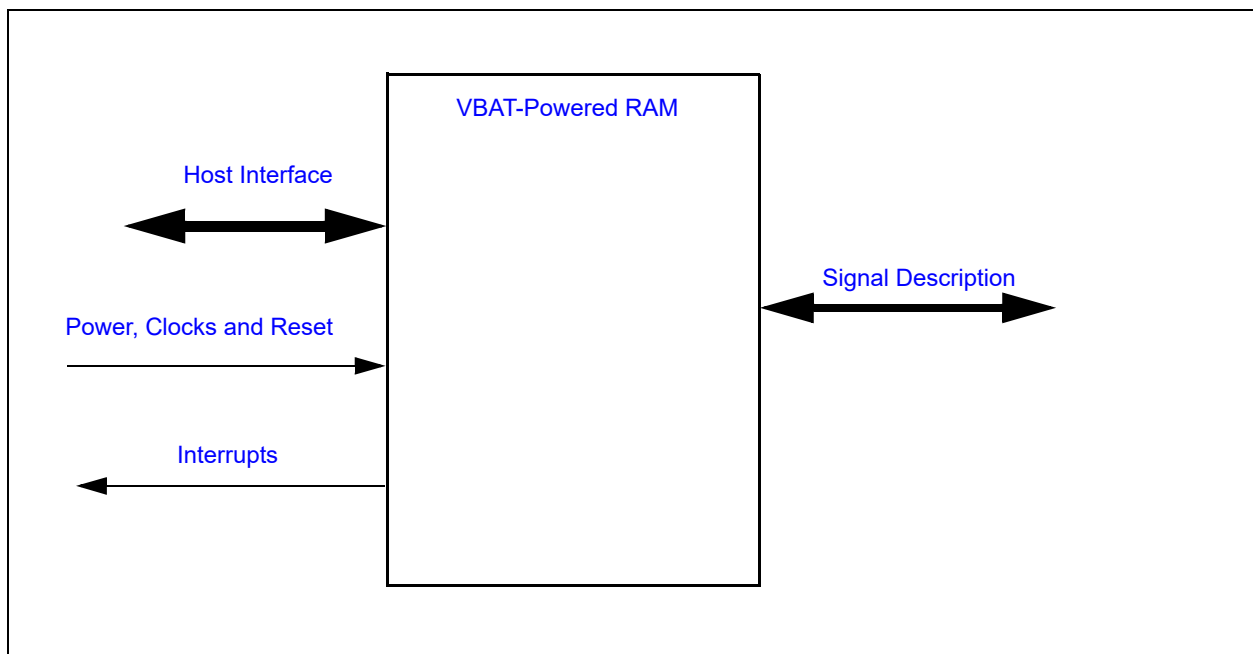

45.5 Signal Description

There are no external signals for this block.

45.6 Host Interface

The contents of the VBAT RAM are accessible only by the Embedded Controller (EC).

MEC1725

45.7 Power, Clocks and Reset

This section defines the Power, Clock, and Reset parameters of the block.

45.7.1 POWER DOMAINS

Name	Description
VTR_CORE	The main power well used when the VBAT RAM is accessed by the EC.
VBAT	The power well used to retain memory state while the main power rail is unpowered.

45.7.2 CLOCK INPUTS

No special clocks are required for this block.

45.7.3 RESETS

Name	Description
RESET_VBAT	This signal resets all the registers and logic in this block to their default state.

45.8 Interrupts

This block does not generate any interrupts.

45.9 Low Power Modes

The VBAT-Powered RAM automatically enters a low power mode whenever it is not being accessed by the EC. There is no chip-level Sleep Enable input.

45.10 Description

FIGURE 45-2: VBAT RAM BLOCK DIAGRAM

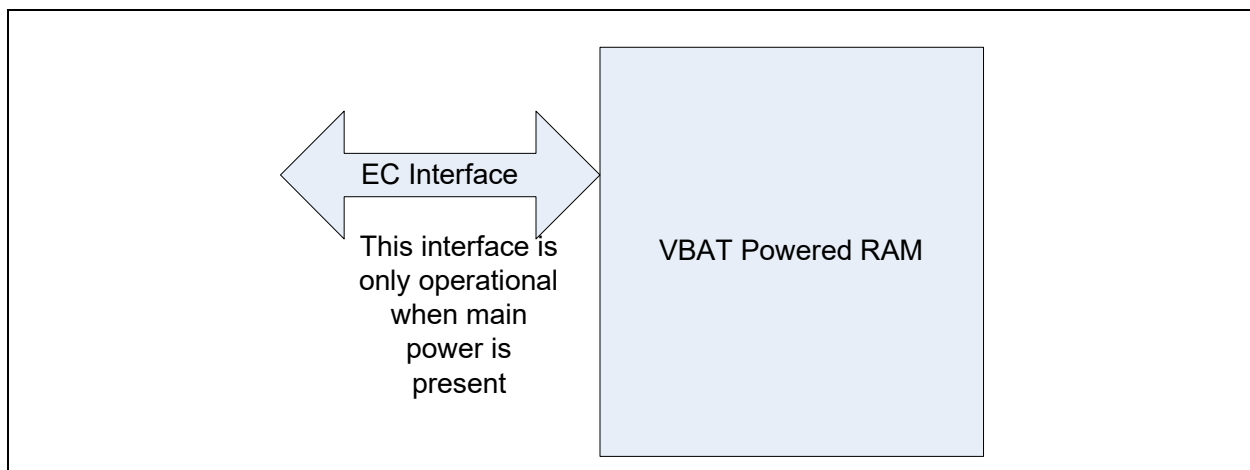

The VBAT Powered RAM provides a 128 Byte Random Accessed Memory that is operational while VTR_CORE is powered, and will retain its values powered by VBAT while VTR_CORE is unpowered. The RAM is organized as a 32 words x 32-bit wide for a total of 128 bytes. This memory can be read/write accessed with 8 bit, 16 bit or 32bit accesses.

The contents of the VBAT RAM is indeterminate after a RESET_VBAT.

Note: Any secret customer information stored on chip in VBAT memory must be encrypted for best security practices.

46.0 VBAT REGISTER BANK

46.1 Introduction

This chapter defines a bank of registers powered by [VBAT](#).

46.2 Interface

This block is designed to be accessed internally by the EC via the register interface.

46.3 Power, Clocks and Reset

This section defines the Power, Clock, and Reset parameters of the block.

46.3.1 POWER DOMAINS

Name	Description
VBAT	The VBAT Register Bank are all implemented on this single power domain.

46.3.2 CLOCK INPUTS

This block does not require any special clock inputs. All register accesses are synchronized to the host clock.

46.3.3 RESETS

Name	Description
RESET_VBAT	This reset signal, which is an input to this block, resets all the logic and registers to their initial default state.

46.4 Interrupts

This block does not generate any interrupt events.

46.5 Low Power Modes

The [VBAT Register Bank](#) is designed to always operate in the lowest power consumption state.

46.6 Description

The VBAT Register Bank block is a block implemented for aggregating miscellaneous battery-backed registers required the host and by the Embedded Controller (EC) Subsystem that are not unique to a block implemented in the EC subsystem.

46.7 EC Registers

Registers for this block are shown in the following summary table. Addresses for each register are determined by adding the offset to the Base Address for the [VBAT Register Bank](#) Block in the Block Overview and Base Address Table in [Section 3.0, "Device Inventory"](#).

TABLE 46-1: REGISTER SUMMARY

Offset	Register Name
00h	Power-Fail and Reset Status Register
04h	TEST
08h	VBAT SOURCE 32kHz Register
0Ch	
10h	TEST
14h	TEST

MEC1725

TABLE 46-1: REGISTER SUMMARY (CONTINUED)

Offset	Register Name
1Ch	TEST
20h	Monotonic Counter Register
24h	Counter HiWord Register
28h	ROM Feature Register
2Ch	TEST
30h	Reserved

46.7.1 POWER-FAIL AND RESET STATUS REGISTER

The Power-Fail and Reset Status Register collects and retains the VBAT RST and WDT event status when [VTR_CORE](#) is unpowered.

Address	00h			
Bits	Description	Type	Default	Reset Event
7	VBAT_RST The VBAT_RST bit is set to '1' by hardware when a RESET_VBAT is detected. This is the register default value. To clear VBAT RST EC firmware must write a '1' to this bit; writing a '0' to VBAT RST has no effect.	R/WC	1	RESET_VBAT
6	SYSRESETREQ This bit is set to '1b' if a RESET_SYS was triggered by an ARM SYSRESETREQ event. This bit is cleared to '0b' when written with a '1b'; writes of a '0b' have no effect.	R/WC	-	-
5	WDT This bit is set to '1b' if a RESET_SYS was triggered by a Watchdog Timer event. This bit is cleared to '0b' when written with a '1b'; writes of a '0b' have no effect.	R/WC	0	RESET_VBAT
4	RESETI This bit is set to '1b' if a RESET_SYS was triggered by a low signal on the nRESET_IN input pin. This bit is cleared to '0b' when written with a '1b'; writes of a '0b' have no effect.	R/WC	0	RESET_VBAT
3	TEST	R/WC	0	RESET_VBAT
2	SOFT_SYS_RESET Status This bit is set to '1b' if a was triggered by an assertion of the SOFT_SYS_RESET bit in the System Reset Register . This bit is cleared to '0b' when written with a '1b'; writes of a '0b' have no effect.	R/WC	0	RESET_VBAT
1	Reserved	RES	-	-
0	Reserved	RES	-	-

46.7.2 VBAT SOURCE 32KHZ REGISTER

Address	08h			
Bits	Description	Type	Default	Reset Event
31:19	Reserved	RES	-	-
18	Internal 32kHz Suppress When enabled the Internal 32kHz VBAT clock source is suppressed (disabled) when VTR goes down. 0 = Suppress Disabled 1 = Suppress Enabled	R/W	0b	RESET_VBAT
17:16	Peripheral 32kHz Source MUX Select for the source of the 32kHz Peripheral Clock. 0 = VTR/VBAT: Internal Silicon Oscillator 1 = VTR/VBAT: XTAL 2 = VTR: PIN 32kHz In; VBAT: Internal Silicon Oscillator 3 = VTR: PIN 32kHz In; VBAT: XTAL	R/W	0b	RESET_VBAT
15:13	Reserved	RES	-	-
12:11	XTAL CNTR[1:0]	R/W	0b	RESET_VBAT
10	XTAL Startup Disable When enabled the XTAL, in Dual-Ended Mode, will enter a low power mode. This can only be set after the XTAL is locked, otherwise the XTAL functionality is not guaranteed.	R/W	0b	RESET_VBAT
9	XTAL XOSEL Select if the XTAL is operating in Single/Dual Ended Mode. 0 = Dual-Ended 1 = Single Ended	R/W	0b	RESET_VBAT
8	XTAL Enable Enables/Starts the XTAL clock operation.	R/W	0b	RESET_VBAT
7:1	Reserved	RES	-	-
0	Internal 32kHz Enable Enables/Starts the 32kHz Internal Silicon Oscillator operation using internal FSM controls. 0 = Disabled 1 = Enabled	R/W	0b	RESET_VBAT

46.7.3 MONOTONIC COUNTER REGISTER

Address	20h			
Bits	Description	Type	Default	Reset Event
31:0	MONOTTONIC_COUNTER Read-only register that increments by 1 every time it is read. It is reset to 0 on a VBAT Power On Reset.	R	0b	RESET_VBAT

MEC1725

46.7.4 COUNTER HIWORD REGISTER

Address	24h			
Bits	Description	Type	Default	Reset Event
31:0	COUNTER_HIWORD Thirty-two bit read/write register. If software sets this register to an incrementing value, based on an external non-volatile store, this register may be combined with the Monotonic Counter Register to form a 64-bit monotonic counter.	R/W	0b	RESET_VBAT

46.7.5 ROM FEATURE REGISTER

Address	28h			
Bits	Description	Type	Default	Reset Event
31:8	Reserved	RES	-	-
7:0	Please refer to Boot ROM documentation for this register usage	R/W	0b	RESET_VBAT

47.0 EC SUBSYSTEM REGISTERS

47.1 Introduction

This chapter defines a bank of registers associated with the EC Subsystem.

47.2 References

None

47.3 Interface

This block is designed to be accessed internally by the EC via the register interface.

47.4 Power, Clocks and Reset

This section defines the Power, Clock, and Reset parameters of the block.

47.4.1 POWER DOMAINS

Name	Description
VTR_CORE	The logic and registers implemented in this block are powered by this power well.

47.4.2 CLOCK INPUTS

This block does not require any special clock inputs. All register accesses are synchronized to the host clock.

47.4.3 RESETS

Name	Description
RESET_SYS	This signal resets all the registers and logic in this block to their default state, except WDT Event Count Register .
RESET_SYS_nWDT	This signal resets the WDT Event Count Register register. This reset is not asserted on a WDT Event.
RESET_VTR	This reset signal is asserted only on VTR_CORE power on.

47.5 Interrupts

This block does not generate any interrupt events.

47.6 Low Power Modes

The [EC Subsystem Registers](#) may be put into a low power state by the chip's Power, Clocks, and Reset (PCR) circuitry. When this block is commanded to sleep it will still allow read/write access to the registers.

47.7 Description

The EC Subsystem Registers block is a block implemented for aggregating miscellaneous registers required by the Embedded Controller (EC) Subsystem that are not unique to a block implemented in the EC subsystem.

47.8 EC-Only Registers

Registers for this block are shown in the following summary table. Addresses for each register are determined by adding the offset to the Base Address for the [EC Subsystem Registers](#) Block in the Block Overview and Base Address Table in [Section 3.0, "Device Inventory"](#).

MEC1725

TABLE 47-1: REGISTER SUMMARY

Offset	Register Name
00h	Reserved
04h	AHB Error Address Register
08h	TEST
0Ch	TEST
10h	TEST
14h	AHB Error Control Register
18h	Interrupt Control Register
1Ch	ETM TRACE Enable Register
20h	Debug Enable Register
28h	WDT Event Count Register
2Ch	TEST
30h	TEST
34h	TEST
38h	TEST
3Ch	TEST
40h	PECI Disable Register
44h	TEST
48h	TEST
54h	Boot ROM Status Register
58h	TEST
5Ch	TEST
60h	TEST
64h	Reserved
68h	TEST
6Ch	TEST
70h	JTAG Master Configuration Register
74h	JTAG Master Status Register
78h	JTAG Master TDO Register
7Ch	JTAG Master TDI Register
80h	JTAG Master TMS Register
84h	JTAG Master Command Register
88h	TEST
90h	Virtual Wire Source Configuration Register
100h	TEST

47.8.1 AHB ERROR ADDRESS REGISTER

Offset	04h			
Bits	Description	Type	Default	Reset Event
31:0	AHB_ERR_ADDR In priority order: 1. AHB address is registered when an AHB error occurs on the processors AHB master port and the register value was already 0. This way only the first address to generate an exception is captured. 2. The processor can clear this register by writing any 32-bit value to this register.	R/WZC	0h	RESET_SYS

47.8.2 AHB ERROR CONTROL REGISTER

Offset	14h			
Bits	Description	Type	Default	Reset Event
7:2	Reserved	RES	-	-
1	TEST	R/W	0h	RESET_SYS
0	AHB_ERROR_DISABLE 1=EC memory exceptions are disabled 0=EC memory exceptions are enabled	R/W	0h	RESET_SYS

47.8.3 INTERRUPT CONTROL REGISTER

Offset	18h			
Bits	Description	Type	Default	Reset Event
31:1	Reserved	RES	-	-
0	NVIC_EN This bit enables Alternate NVIC IRQ's Vectors. The Alternate NVIC Vectors provides each interrupt event with a dedicated (direct) NVIC vector. 1=Alternate NVIC vectors enabled 0=Alternate NVIC vectors disabled	R/W	1b	RESET_SYS

47.8.4 ETM TRACE ENABLE REGISTER

Offset	1Ch			
Bits	Description	Type	Default	Reset Event
31:1	Reserved	RES	-	-
0	TRACE_EN This bit enables the ARM TRACE debug port (ETM/ITM). The Trace Debug pins are forced to the TRACE functions. 1=ARM TRACE port enabled 0=ARM TRACE port disabled	R/W	0b	RESET_SYS

MEC1725

47.8.5 DEBUG ENABLE REGISTER

Offset	20h			
Bits	Description	Type	Default	Reset Event
31:6	Reserved	RES	-	-
5	DEBUG_ENABLE_LOCK 1= ARM JTAG completely disabled. This means JTAG cannot be used for firmware/hardware debug. However, only Boundary Scan is accessible through JTAG port. 0= ARM JTAG accessible through JTAG.	R/W1S	0h	RESET_SYS
4	BOUNDARY SCAN PORT ENABLE 1= Enable Boundary scan port enable 0= Disable Boundary scan port enable If disabled, the Boundary scan Tap controller is not accessible via JTAG Port.	R/W	0h	RESET_SYS
3	DEBUG_PU_EN If this bit is set to '1b' internal pull-up resistors are automatically enabled on the appropriate debugging port wires whenever the debug port is enabled (the DEBUG_EN bit in this register is '1b' and the JTAG_RST# pin is high). The setting of DEBUG_PIN_CFG determines which pins have pull-ups enabled when the debug port is enabled.	R/W	0h	RESET_SYS
2:1	DEBUG_PIN_CFG This field determines which pins are affected by the TRST# debug enable pin. 3=Reserved 2=The pins associated with the JTAG TCK and TMS switch to the debug interface when TRST# is de-asserted high. The pins associated with TDI and TDO remain controlled by the associated GPIO. This setting should be used when the ARM Serial Wire Debug (SWD) is required for debugging and the Serial Wire Viewer is not required 1=The pins associated with the JTAG TCK, TMS and TDO switch to the debug interface when TRST# is de-asserted high. The pin associated with TDI remains controlled by the associated GPIO. This setting should be used when the ARM Serial Wire Debug (SWD) and Serial Wire Viewer (SWV) are both required for debugging 0=All four pins associated with JTAG (TCK, TMS, TDI and TDO) switch to the debug interface when TRST# is de-asserted high. This setting should be used when the JTAG TAP controller is required for debugging	R/W	0h	RESET_SYS
0	DEBUG_EN This bit enables the JTAG/SWD debug port. 1=JTAG/SWD port enabled. A high on TRST# enables JTAG or SWD, as determined by SWD_EN 0=JTAG/SWD port disabled. JTAG/SWD cannot be enabled (the TRST# pin is ignored and the JTAG signals remain in their non-JTAG state)	R/W	0b	RESET_SYS
Note: Boot ROM updates this register value on exit. Refer to the Boot ROM document for details.				

47.8.6 WDT EVENT COUNT REGISTER

Offset	28h			
Bits	Description	Type	Default	Reset Event
31:4	Reserved	RES	-	-
3:0	<p>WDT_EVENT_COUNT</p> <p>This field is cleared to 0 on a reset triggered by the main power on reset, but <u>not</u> on a reset triggered by the Watchdog Timer.</p> <p>This field needs to be written by application to indicate the number of times a WDT fired before loading a good EC code image. Note 1</p>	R/W	0b	RESET_SYS_n-WDT
<p>Note 1: The recommended procedure is to first clear the WDT Status Register followed by incrementing the WDT_EVENT_COUNT.</p>				

47.8.7 PECI DISABLE REGISTER

Offset	40h			
Bits	Description	Type	Default	Reset Event
31:1	Reserved	RES	-	-
0	<p>PECI_DISABLE</p> <p>This bit reduces leakage current through the CPU voltage reference pin if PECE or SB-TSI are not used.</p> <p>1=The VREF_VTT function is disabled, independent of the mux setting of the GPIO that shares the pin. The GPIO that shares the pin is not disabled 0=The VREF_VTT pin is enabled</p>	R/W	0b	RESET_SYS

47.8.8 BOOT ROM STATUS REGISTER

Offset	54h			
Bits	Description	Type	Default	Reset Event
31:2	Reserved	RES	-	-
1	<p>WDT_EVENT</p> <p>WDT event status for Boot ROM</p>	R/W1C	0	RESET_SYS_nWDT
0	<p>VTR_RESET_STATUS</p> <p>VTR_CORE reset status for Boot ROM</p>	R/W1C	1	RESET_SYS

MEC1725

47.8.9 JTAG MASTER CONFIGURATION REGISTER

Offset	70h			
Bits	Description	Type	Default	Reset Event
31:4	Reserved	R	-	-
3	MASTER_SLAVE This bit controls the direction of the JTAG port. 1=The JTAG Port is configured as a Master 0=The JTAG Port is configured as a Slave	R/W	0h	RESET _SYS
2:0	JTM_CLK This field determines the JTAG Master clock rate, derived from the 48MHz master clock. 7=375KHz 6=750KHz 5=1.5Mhz 4=3Mhz 3=6Mhz 2=12Mhz 1=24MHz 0=Reserved.	R/W	3h	RESET _SYS

47.8.10 JTAG MASTER STATUS REGISTER

Offset	74h			
Bits	Description	Type	Default	Reset Event
31:1	Reserved	R	-	-
0	JTM_DONE This bit is set to '1b' when the JTAG Master Command Register is written. It becomes '0b' when shifting has completed. Software can poll this bit to determine when a command has completed and it is therefore safe to remove the data in the JTAG Master TDO Register and load new data into the JTAG Master TMS Register and the JTAG Master TDI Register .	R	-	RESET _SYS

47.8.11 JTAG MASTER TDO REGISTER

Offset	78h			
Bits	Description	Type	Default	Reset Event
31:0	JTM_TDO When the JTAG Master Command Register is written, from 1 to 32 bits are shifted into this register, starting with bit 0, from the JTAG_TDO pin. Shifting is at the rate determined by the JTM_CLK field in the JTAG Master Configuration Register	R/W	0h	RESET_SYS

47.8.12 JTAG MASTER TDI REGISTER

Offset	7Ch			
Bits	Description	Type	Default	Reset Event
31:0	JTM_TDI When the JTAG Master Command Register is written, from 1 to 32 bits are shifted out of this register, starting with bit 0, onto the JTAG_TDI pin. Shifting is at the rate determined by the JTM_CLK field in the JTAG Master Configuration Register	R/W	0h	RESET_SYS

47.8.13 JTAG MASTER TMS REGISTER

Offset	80h			
Bits	Description	Type	Default	Reset Event
31:0	JTM_TMS When the JTAG Master Command Register is written, from 1 to 32 bits are shifted out of this register, starting with bit 0, onto the JTAG_TMS pin. Shifting is at the rate determined by the JTM_CLK field in the JTAG Master Configuration Register	R/W	0h	RESET_SYS

MEC1725

47.8.14 JTAG MASTER COMMAND REGISTER

Offset	84h			
Bits	Description	Type	Default	Reset Event
31:5	Reserved	R	-	-
4:0	<p>JTM_COUNT</p> <p>If the JTAG Port is configured as a Master, writing this register starts clocking and shifting on the JTAG port. The JTAG Master port will shift JTM_COUNT+1 times, so writing a '0h' will shift 1 bit, and writing '31h' will shift 32 bits. The signal JTAG_CLK will cycle JTM_COUNT+1 times. The contents of the JTAG Master TMS Register and the JTAG Master TDI Register will be shifted out on the falling edge of JTAG_CLK and the JTAG Master TDO Register will get shifted in on the rising edge of JTAG_CLK.</p> <p>If the JTAG Port is configured as a Slave, writing this register has no effect.</p>	W	-	RESET_SYS

47.8.15 VIRTUAL WIRE SOURCE CONFIGURATION REGISTER

Offset	90h			
Bits	Description	Type	Default	Reset Event
31:3	Reserved	RES	-	-
2:0	<p>VWIRE_SOURCE</p> <p>VWIRE_SOURCE [2] should always be programmed to 1b.</p> <p>VWIRE_SOURCE [1]</p> <p>0 = The hardware source MBX_Host_SMI affects the state of the SMI# (SRC1) bit of the SMVW02 register. 1 = The hardware source MBX_Host_SMI does not affect the SMI# (SRC1) bit of the SMVW02 register.</p> <p>Note: Firmware can always write to the SRC1 bit of the SMVW02 register.</p> <p>VWIRE_SOURCE [0]</p> <p>0=The hardware source EC_SCI# affects the state of the SCI# (SRC0) bit of the SMVW02 register. 1= The hardware source EC_SCI# does not affect the SCI# (SRC0) bit of the SMVW02 register.</p> <p>Note: Firmware can always write to the SRC0 bit of the SMVW02 register.</p>	RW	7h	RESET_SYS

47.8.16 EMBEDDED RESET ENABLE REGISTER

Offset	B0h			
Bits	Description	Type	Default	Reset Event
7:1	Reserved	RES	-	-
0	EMBEDDED_RESET_ENABLE 1 0 = Embedded Reset Engine is Disable 1 = Embedded Reset Engine is Enable	R/W	0h	RESET_SYS

Note 1: Embedded Register feature is enabled using OTP bit programming by the customer.
Note 2: This register is programmed by the Boot ROM based on OTP programming.
Note 3: The register default value is trimmed in OTP after characterization.

47.8.17 EMBEDDED RESET TIMEOUT VALUE REGISTER

Offset	B4h			
Bits	Description	Type	Default	Reset Event
7:3	Reserved	RES	-	-
2:0	EMBEDDED_RESET_TIMEOUT_VALUE 1 0 = 6s 1 = 7s 2 = 8s 3 = 9s 4 = 10s 5 = 11s 6 = 12s 7 = 14s	R/W	0h	RESET_SYS

Note 1: Embedded Register feature is enabled using OTP bit programming by the customer.
Note 2: This register is programmed by the Boot ROM based on OTP programming.
Note 3: The register default value is trimmed in OTP after characterization.

47.8.18 EMBEDDED RESET STATUS REGISTER

Offset	B8h			
Bits	Description	Type	Default	Reset Event
7:1	Reserved	RES	-	-
0	EMBEDDED_RESET_STATUS 0 = Embedded Reset did not occur 1 = Embedded Reset Engine occurred	R/W	0h	RESET_SYS_n-WDT

47.8.19 EMBEDDED RESET CURRENT COUNT REGISTER

Offset	BCh			
Bits	Description	Type	Default	Reset Event
31:19	Reserved	RES	-	-
18:0	EMBEDDED_RESET_CURRENT_COUNT This register tells the current count of the embedded reset counter.	R	0h	RESET_SYS

MEC1725

Note: If Embedded Reset functionality is used, then VCI_OUT needs to control Power Supply (to generate the Power On Reset). If VCI_OUT does not control the power, when Embedded reset functionality is enabled, there has to be an external Reset applied to the chip after the VCI_OUT is asserted to reset the chip.

48.0 SECURITY FEATURES

48.1 Overview

This device includes a set of components that can support a high level of system security. Hardware support is provided for:

- Authentication, using public key algorithms
- Integrity, using Secure Hash Algorithms (SHA)
- Privacy, using symmetric encryption (Advanced Encryption Standard, AES)
- Entropy, using a true Random Number Generator

48.2 References

- American National Standards Institute, "Public Key Cryptography for the Financial Services Industry: Key Agreement and Key Transport Using Elliptic Curve Cryptography", X9.63-2011, December 2011
- American National Standards Institute, "Public Key Cryptography for the Financial Services Industry: The Elliptic Curve Digital Signature Algorithm (ECDSA)", X9.62-2005, November 2005
- International Standards Organization, "Information Technology - Security techniques - Cryptographic techniques based on elliptic curves -- Part 2: Digital Signatures", ISO/IEC 15946-2, December 2002
- National Institute of Standards and Technology, "Secure Hash Standard (SHS)", FIPS Pub 180-4, March 2012
- National Institute of Standards and Technology, "Digital Signature Standard (DSS)", FIPS Pub 186-3, June 2009
- National Institute of Standards and Technology, "Advanced Encryption Standard (AES)", FIPS Pub 197, November 2001
- National Institute of Standards and Technology, "Recommendation for Block Cipher Modes of Operation", FIPS SP 800-38A, 2001
- RSA Laboratories, "PKCS#1 v2.2: RSA Cryptography Standard", October 2012

48.3 Terminology

There is no terminology defined for this section.

48.4 Interface

This block is designed to be accessed internally via a registered host interface.

FIGURE 48-1: I/O DIAGRAM OF BLOCK

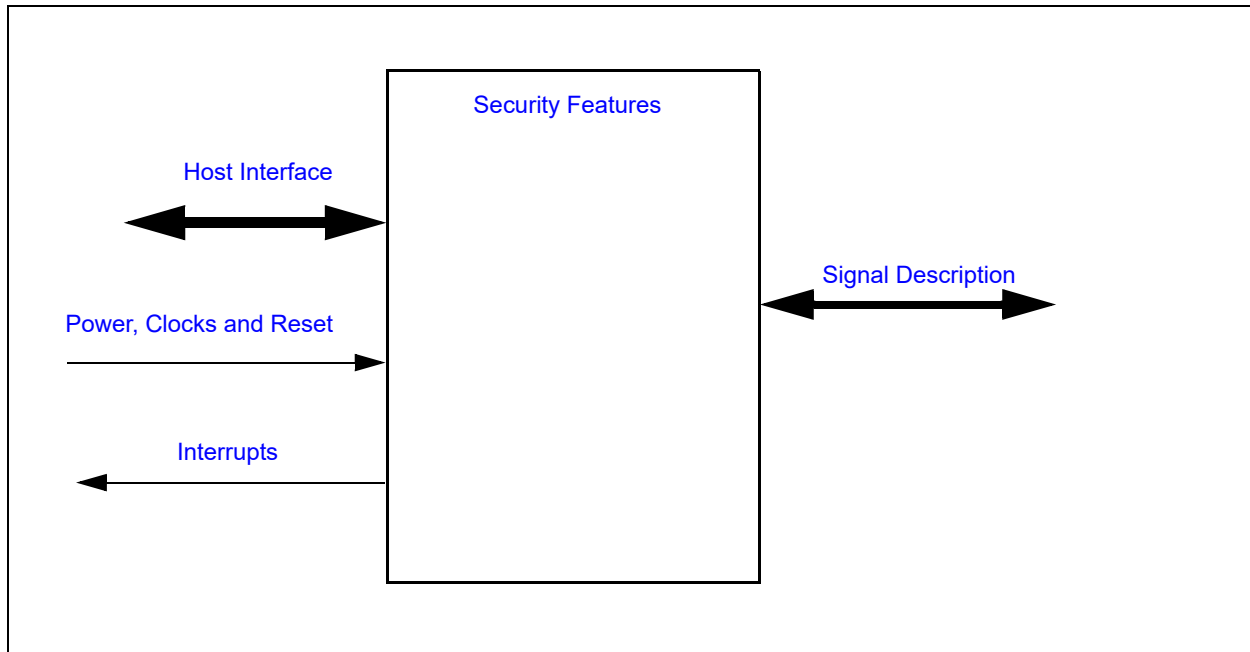

48.5 Signal Description

There are no external signals for this block.

48.6 Host Interface

Registers for the cryptographic hardware are accessible by the EC.

48.7 Power, Clocks and Reset

48.7.1 POWER DOMAINS

Name	Description
VTR_CORE	The main power well used when the VBAT RAM is accessed by the EC.

48.7.2 CLOCK INPUTS

No special clocks are required for this block.

48.7.3 RESETS

Name	Description
RESET_SYS	This signal resets all the registers and logic in this block to their default state.

48.8 Interrupts

This section defines the Interrupt Sources generated from this block.

Source	Description
Public Key Engine	
PKE_ERROR	Public Key Engine core error detected
PKE END	Public Key Engine completed processing
Symmetric Encryption	
AES	Symmetric Encryption block completed processing
Cryptographic Hashing	
HASH	HASH
Random Number Generator	
RNG	Random Number Generator filled its FIFO

48.9 Low Power Modes

The [Security Features](#) may be put into a low power state by the chip's Power, Clocks, and Reset (PCR) circuitry.

48.10 Description

The security hardware incorporates the following functions:

48.10.1 SYMMETRIC ENCRYPTION/DECRYPTION

Standard AES encryption and decryption, with key sizes of 128 bits, 192 bits and 256 bits, are supported with a hardware accelerator. AES modes that can be configured include Electronic Code Block (ECB), Cipher Block Chaining (CBC), Counter Mode (CTR), Output Feedback (OFB), Cipher Feedback (CFB), Counter with CBC-MAC (CCM) and Galois/Counter Mode (GCM).

48.10.2 CRYPTOGRAPHIC HASHING

Standard SHA hash algorithms, including SHA-1, SHA-224, SHA-256, SHA-384 and SHA-512 are supported by hardware.

48.10.3 PUBLIC KEY CRYPTOGRAPHIC ENGINE

A large variety of public key algorithms are supported directly in hardware. These include:

- RSA encryption and decryption, with key sizes of 1024 bits, 2048 bits, 3072 bits and 4096 bits
- Elliptic Curve point multiply, with all standard NIST curves, using either binary fields or prime fields
- Elliptic Curve point multiply with Curve25519, Curve448 and Edwards Curves
- The Elliptic Curve Digital Signature Algorithm (ECDSA), using all supported NIST curves
- The Elliptic Curve Korean Certificate-based Digital Signature Algorithm (EC-KCDSA), using all supported NIST curves
- The Edwards-curve Digital Signature Algorithm (EdDSA), using Curve25519
- ECC support for special curves Curve448 Ed25519 are inbuilt in hardware.
- Miller-Rabin primality testing

MEC1725

The Public Key Engine includes a 8KB cryptographic SRAM, which can be accessed by the EC when the engine is not in operation. With its private SRAM memory, the Public Key Engine can process public key operations independently of the EC.

48.10.4 TRUE RANDOM NUMBER GENERATOR

A true Random Number Generator, which includes a 1K bit FIFO for pre-calculation of random bits. This block has Health Check function included with it.

48.10.5 MONOTONIC COUNTER

The Monotonic Counter is defined in [Section 46.7.3, "Monotonic Counter Register"](#). The counter automatically increments every time it is accessed, as long as VBAT power is maintained. If it is necessary to maintain a monotonic counter across VBAT power cycles, the [Counter HiWord Register](#) can be combined with the Monotonic Counter Register to form a 64-bit monotonic counter. Firmware would be responsible for updating the Counter HiWord on a VBAT POR. The HiWord could be maintained in a non-volatile source, such as the EEPROM or an external SPI Flash.

48.10.6 CRYPTOGRAPHIC API

The Boot ROM includes an API for direct software access to cryptographic functions. API functions for Hashing and AES include a DMA interface, so the operations can function on large blocks of SRAM with a single call.

48.11 Registers

There are no registers directly accessible to the application in this block. User must use the API's to use this block. Please refer to the Boot ROM document for the list of API's.

48.11.1 REGISTERS SUMMARY

The Public Key Engine, The Random Number Generator, the Hash Engine and the Symmetric Encryption Engine are all listed in the Block Overview and Base Addresses in [Section 3.0, "Device Inventory"](#).

49.0 OTP BLOCK

49.1 Introduction

The [OTP Block](#) provides a means of programming and accessing a block of One Time Programmable memory.

49.2 Terminology

None.

49.3 Interface

FIGURE 49-1: OTP BLOCK INTERFACE DIAGRAM

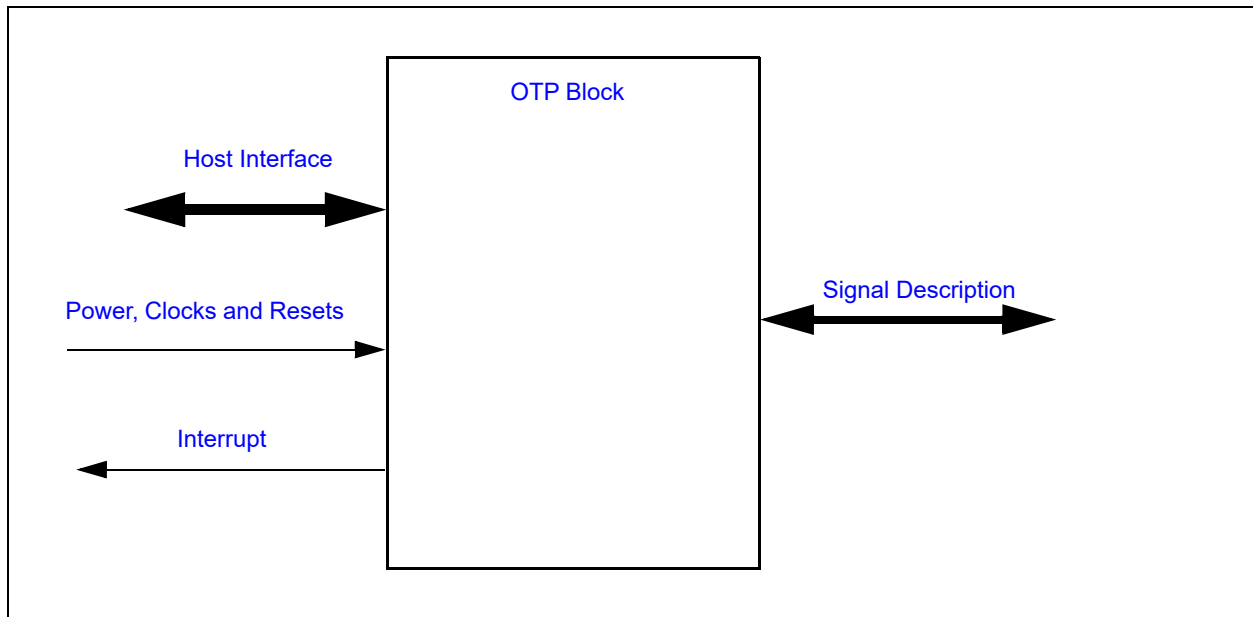

49.4 Signal Description

There are no external signals from this block

49.5 Host Interface

The registers defined for the [OTP Block](#) are accessible by the EC.

49.6 Interrupt Interface

TABLE 49-1: INTERRUPT SIGNALS

Source	Description
OTP_READY	The OTP_READY interrupt will be generated whenever an OTP command is completed.

49.7 Power, Clocks and Resets

This section defines the Power, Clock, and Reset parameters of the block.

MEC1725

49.7.1 POWER DOMAINS

TABLE 49-2: POWER SOURCES

Name	Description
VTR_CORE	This power well sources all of the registers and logic in this block, except where noted.
VTR	This is the IO voltage for the block.

49.7.2 CLOCKS

This section describes all the clocks in the block, including those that are derived from the I/O Interface as well as the ones that are derived or generated internally.

TABLE 49-3: CLOCKS

Name	Description
48MHz	This clock signal drives selected logic (e.g., counters).

49.7.3 RESETS

TABLE 49-4: RESET SIGNALS

Name	Description
RESET_SYS	This reset signal resets all of the registers and logic in this block.

49.8 Low Power Modes

The OTP always comes up in low power mode and stays in that state unless the firmware needs to use it

49.9 Description

The [OTP Block](#) has a capacity of 8 K bits arranged as 1K x 8 bits.

Note: Any secret customer information stored on chip in OTP memory must be encrypted for best security practices

49.10 OTP Memory Map

Please refer to Boot ROM document for this information.

TABLE 49-5: REGISTER SUMMARY

Offset	Register Name
44h	OTP Write Lock Register
48h	OTP Read Lock Register
4Ch	OTP Write Byte Lock Register
50h	OTP Read Byte Lock Register

49.10.1 OTP WRITE LOCK REGISTER

Offset	44h			
Bits	Description	Type	Default	Reset Event
31:0	OTP_WRLOCK When any of these bits are set, the corresponding 32 byte range in the OTP is not writable.	R/W1S	0h	RESET_SYS

49.10.2 OTP READ LOCK REGISTER

Offset	48h			
Bits	Description	Type	Default	Reset Event
31:0	OTP_RDLOCK When any of these bits are set, the corresponding 32 byte range in the OTP is not readable.	R/W1S	0h	RESET_SYS

49.10.3 OTP WRITE BYTE LOCK REGISTER

Offset	4Ch			
Bits	Description	Type	Default	Reset Event
31:0	OTP_WRITE_BYTE_LOCK Each bit locks write to a byte in the OTP range starting byte 320 to 351 0=Not Locked 1=Locked	R/W1S	0h	RESET_SYS

49.10.4 OTP READ BYTE LOCK REGISTER

Offset	50h			
Bits	Description	Type	Default	Reset Event
31:0	OTP_READ_BYTE_LOCK Each bit locks read to a byte in the OTP range starting byte 320 to 351 0=Not Locked 1=Locked	R/W1S	0h	RESET_SYS

Note 1: OTP Memory can be locked by writing to OTP bytes 1012 - 1019. Boot ROM will then lock the region on every Boot preventing the code that is loaded from accessing this memory location.

2: Application FW can write to the above lock registers and lock the memory region preventing other code loaded from accessing the locked region. This is useful in multistage boot loaders

50.0 GLUE (VCC POWER-GOOD GENERATION) LOGIC

50.1 General Description

The [Glue \(VCC Power-Good Generation\) Logic](#) provides a special purpose hardware function for determining Main Power status in both Running (S0) and Connected Standby (S0ix) system states. This is required in recent systems which may turn off some of the Main power regulators in the S0ix state, substituting a lower-current, higher-efficiency regulator chain. For this reason, there are two Power Good input pins, which are switched in based on the system power state.

This block also has connections to eSPI Virtual Wires, which may be selected as inputs instead of physical pins. See the applicable eSPI Block Specification for this product.

50.2 Power, Clocks and Reset

50.2.1 POWER DOMAIN

This block is on VTR power.

50.2.2 CLOCKS

The [Glue \(VCC Power-Good Generation\) Logic](#) uses the EC main clock.

50.2.3 RESET

TABLE 50-1: RESET DOMAINS

Name	Description
RESET_SYS	This is the basic chip-level reset, coming from various sources which include VTR POR, and may also include a Firmware-generated Soft Reset, and/or a Watchdog event. See the chip-level definition.
PCI Reset	This is a signal indicating that the CPU Reset has been activated by the Chipset. It is selected at the chip level from a pin, or it may come from the eSPI Virtual Wire PLTRST#.

50.3 Interrupts

The [PWRGD Signal Monitor Register Set on page 665](#) provides an interrupt to firmware from this feature set. Its assignment to a firmware IRQ is made at the chip level.

Any required SMI or SCI event to the Host Chipset, runtime or wake, will be generated by firmware in response to the interrupt provided here.

50.4 Register Set

The [Glue \(VCC Power-Good Generation\) Logic](#) registers occupy a 1K byte region in the address space of the EC, at the Base Address established by the chip-level design. This region contains some registers that are available to the Host CPU as Runtime registers, and others that are accessible only to EC Firmware (EC-Only).

The Runtime Register occupies a region in the Host CPU's I/O or Memory space, at a base address established by BAR configuration.

TABLE 50-2: RUNTIME REGISTER SET

Host Offset	EC Offset	Register Description
04h	04h	Section 50.5.1.3, "S0ix State Detection Enable Register"

TABLE 50-3: EC-ONLY REGISTER SET

EC Offset	Register Description
10Ch	Section 50.5.1.1, "PWRGD_STATE Source Configuration Register"
110h	Section 50.5.1.2, "S0ix State Detection Configuration Register"
128h	Section 50.5.3.1, "Signal Monitor State Register"
12Ch	Section 50.5.3.2, "Signal Monitor Interrupt Pending Register"
130h	Section 50.5.3.3, "Signal Monitor Interrupt Enable Register"

MEC1725

50.5 VCC_PWRGD2 Signal Function

VCC_PWRGD2 is substituted for the original single input from the system (VCC_PWRGD), because it is now a more complex function of multiple additional inputs as well.

Two new input signals SLP_S0# and CPU_C10 add to this function, to detect entry into the S0ix (Connected Standby / S0 Idle) system state. This is still an S0 power state, but at greatly reduced current in the system. One new parallel Power Good input (PWRGD_S0IX) is added for signaling of Power Good from an alternate power delivery path in S0ix mode.

VCC_PWRGD, PWRGD_S0IX and SLP_S0# are always physical input pins. CPU_C10 is a physical input that can be provided instead by the eSPI Virtual Wire HOST_C10.

The FW_PGSEL bit is intended to be used to select a mode of operation in which only firmware performs the selection between the inputs VCC_PWRGD and PWRGD_S0IX. A '1' in this bit bypasses the requirement S0ix=1, and allows firmware to provide the switching control directly.

TABLE 50-4: VCC_PWRGD2 SELECTION

PWRGD_STATE_SOURCE Field (Binary)	S0ix (Note 50-1)	FW_PGSEL Bit	VCC_PWRGD Pin	PWRGD_S0IX Pin	VCC_PWRGD2 (PWRGD_STATE)
XX	0	0	0	X	0
XX	0	0	1	X	1
00	1	X	0	X	0
00	1	X	1	X	1
01	1	X	X	0	0
01	1	X	X	1	1
11	1	X	0	X	0
11	1	X	X	0	0
11	1	X	1	1	1
00	X	1	0	X	0
00	X	1	1	X	1
01	X	1	X	0	0
01	X	1	X	1	1
11	X	1	0	X	0
11	X	1	X	0	0
11	X	1	1	1	1

Note 50-1 S0ix (S0 Idle State, Connected Standby) is a determination made by monitoring one or two signals from the Chipset. The '1' state indicates that the Chipset has dropped from the S0 state to S0ix. See [Section 50.5.1.2, "S0ix State Detection Configuration Register," on page 662.](#)

50.5.1 [Glue \(VCC Power-Good Generation\) Logic REGISTER SET](#)

See also [FIGURE 50-1: VCC_PWRGD2 Generation on page 664](#) for an overview of the functionality controlled by these registers. The term Power-Good State (or the mnemonic PWRGD_STATE) refers to the generation of the VCC_PWRGD2 signal state.

50.5.1.1 PWRGD_STATE Source Configuration Register

For the low-power S0 state S0ix only, this register defines whether the VCC_PWRGD2 input term comes from the physical pin VCC_PWRGD, or from the PWRGD_S0IX pin, or from a combination of both.

VCC_PWRGD2 comes only from the VCC_PWRGD signal in all states other than the S0ix state or FW_PGSEL mode, and this register has no effect.

The S0ix state is detected from inputs selected by the setting of the [S0ix State Detection Configuration Register on page 662](#).

Offset	10Ch			
Bits	Description	Type	Default	Reset Event
7:2	Reserved	R	0h	-
1:0	PWRGD_STATE_SOURCE 11=VCC_PWRGD2 is the logical expression (VCC_PWRGD) & (PWRGD_S0IX) 10= Reserved 01=VCC_PWRGD2 comes from the pin input PWRGD_S0IX. 00=VCC_PWRGD2 comes from the pin input VCC_PWRGD (default).	R/W	0h	RESET_SYS

MEC1725

50.5.1.2 S0ix State Detection Configuration Register

This register defines how the S0ix system state is detected.

If all conditions are met, as defined by the S0IX_DET_SOURCE field, and the S0IX_DET_EN bit in the [S0ix State Detection Enable Register on page 663](#) is also set to '1', then the S0ix term is defined as '1'; else it is defined as '0'.

While S0ix==0 and bit FW_PGSEL==0, the only source of VCC_PWRGD2 is the VCC_PWRGD input pin.

While S0ix==1, or bit FW_PGSEL==1, then VCC_PWRGD2 is selected as programmed in the [PWRGD_STATE Source Configuration Register on page 661](#).

Offset	110h			
Bits	Description	Type	Default	Reset Event
7:6	Reserved	R	0h	-
5	FW_PGSEL 1=The S0ix State is not used directly for PWRGD input selection, and EC firmware is in direct control of which input is selected. The S0ix State is still presented to the Signal Monitor State Register on page 665 , where firmware may monitor it via polling or interrupts. 0=S0ix State affects PWRGD input selection to VCC_PWRGD2.	R/W	0h	RESET_SYS
4	C10_SOURCE 1=C10 comes from the Virtual Wire HOST_C10 (eSPI only). 0=C10 comes from the physical pin input CPU_C10 (default).	R/W	0h	RESET_SYS
3	C10_INV 1=C10 is from an inverted, low-active, source. 0=C10 is from a high-active source (default).	R/W	0h	RESET_SYS
2	SLP_S0_INV 1=SLP_S0# pin input is from an inverted, high-active, source. 0=SLP_S0# pin input is from a low-active source (default).	R/W	0h	RESET_SYS
1:0	S0IX_DET_SOURCE 11=S0ix State is detected as the C10 function AND the SLP_S0 function both active, as selected by their respective polarity and source. 10=S0ix State is detected as the C10 function active. 01=S0ix State is detected as the SLP_S0 function active. 00=S0ix State is not supported, and is presented as a constant '0' (default).	R/W	0h	RESET_SYS

Note: To avoid glitches on VCC_PWRGD2 during configuration, the C10_SOURCE, C10_INV and SLP_S0_INV bits should be configured first, as well as proper chip-level configuration of the input pin(s) themselves for these alternate functions. Only then should the S0IX_DET_SOURCE field be set to a non-zero value. Glitches on VCC_PWRGD2 are forbidden to propagate to the system Chipset, and can lead to corruption of state information there regardless of the system's actual power state.

50.5.1.3 S0ix State Detection Enable Register

This register allows the S0ix system state to be detected, for purposes of switching to an alternate pin for the VCC_PWRGD2 detection. While this register is in its default state, only the VCC_PWRGD pin is used as VCC_PWRGD2.

Since the S0IX_DET_EN bit is reset to 0 by every chip-level [PCI Reset](#) event, it is intended for BIOS software (or firmware, alternatively) to re-write it to '1' before the first subsequent entry into the S0ix state, if switching to use the alternate PWRGD_S0IX pin is needed during the S0ix state.

Host / EC Offset	04h			
Bits	Description	Type	Default	Reset Event
7:1	Reserved	R	0h	-
0	S0IX_DET_EN 1=S0ix State detection is enabled according to the settings in the S0ix State Detection Configuration Register on page 662 . 0=S0ix State detection is not enabled (default).	R/W	0h	PCI Reset

MEC1725

50.5.2 VCC_PWRGD2 BLOCK DIAGRAM

A block diagram for this feature is shown below, for illustration purposes only.

FIGURE 50-1: VCC_PWRGD2 GENERATION

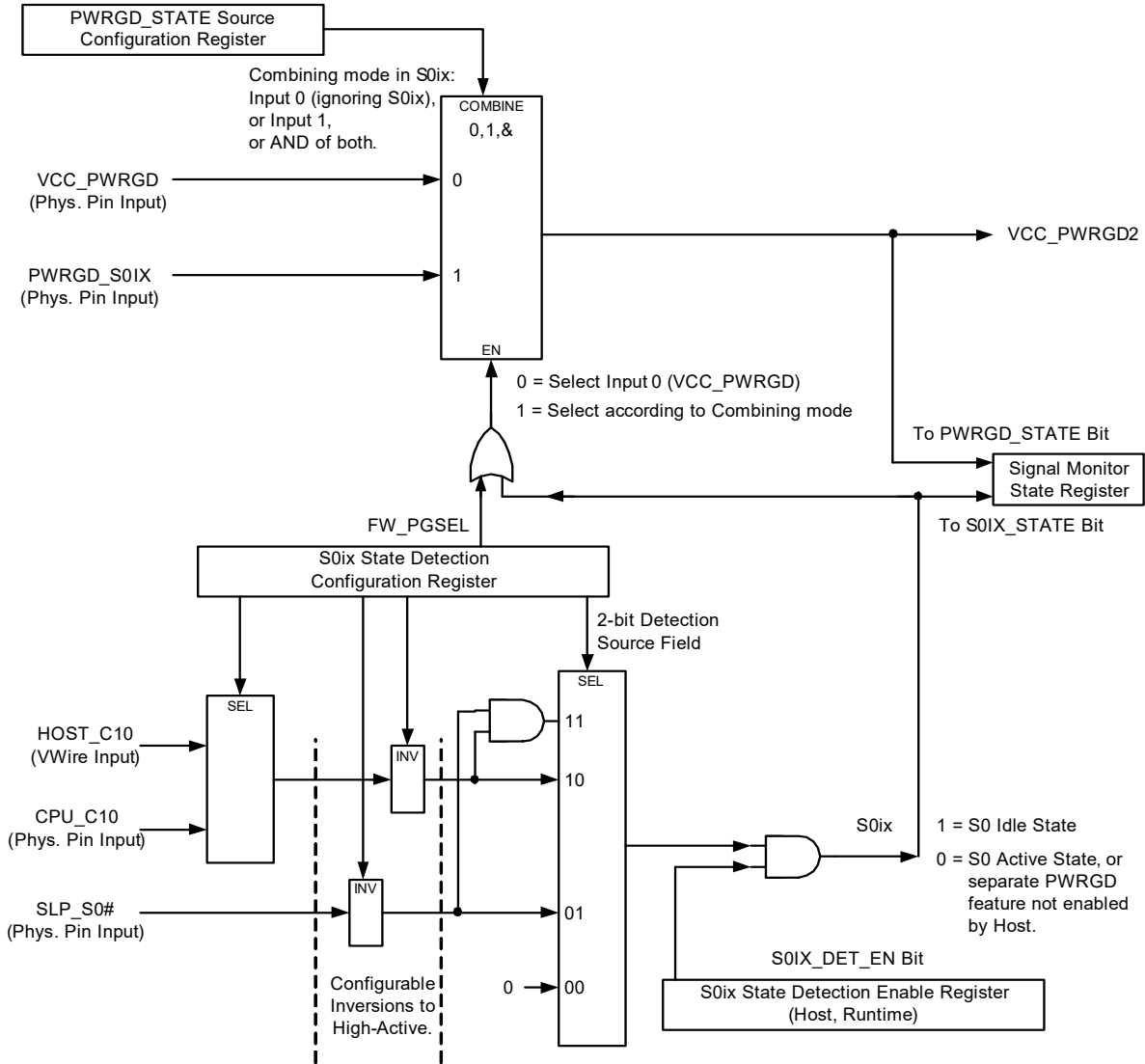

50.5.3 PWRGD SIGNAL MONITOR REGISTER SET

These registers provide status and interrupt reporting to firmware.

50.5.3.1 Signal Monitor State Register

This register provides signal states for Firmware to be able to monitor the workings of the various [Glue \(VCC Power-Good Generation\) Logic](#) features. Note that pins must be configured appropriately before they can be seen in these bits.

Offset	128h			
Bits	Description	Type	Default	Reset Event
31:2	Reserved	R	0h	-
1	S0IX_STATE This bit reflects the state of the internally derived S0ix signal.	R	X (shows state derived from pins)	-
0	PWRGD_STATE This bit reflects the state of the VCC_PWRGD2 signal generated by this block.	R	X (shows state derived from pins)	-

50.5.3.2 Signal Monitor Interrupt Pending Register

This register provides edge detection for bits in the Signal Monitoring State Register.

Offset	12Ch			
Bits	Description	Type	Default	Reset Event
31:2	Reserved	R	0h	-
1	S0IX_STATE Set to '1' on each edge of the corresponding Signal Monitor State bit.	R/WC	0h	RESET_SYS
0	PWRGD_STATE Set to '1' on each edge of the corresponding Signal Monitor State bit.	R/WC	0h	RESET_SYS

50.5.3.3 Signal Monitor Interrupt Enable Register

This register provides Interrupt Enables for corresponding bits in the Interrupt Pending Register.

Offset	130h			
Bits	Description	Type	Default	Reset Event
31:2	Reserved	R	0h	-
1	S0IX_STATE Enables interrupts from the corresponding Interrupt Pending bit.	R/W	0h	RESET_SYS
0	PWRGD_STATE Enables interrupts from the corresponding Interrupt Pending bit.	R/W	0h	RESET_SYS

MEC1725

51.0 TEST MECHANISMS

51.1 ARM Test Functions

Test mechanisms for the ARM are described in [Section 5.0, "ARM M4 Based Embedded Controller"](#). If JTAG is enabled, hot plugging of JTAG connector is supported in the chip.

51.2 JTAG Boundary Scan

Note: Boundary Scan operates in 4-wire JTAG mode only. This is not supported by 2-wire SWD.

JTAG Boundary Scan includes registers and functionality as defined in IEEE 1149.1 and the MEC1725 BSDL file. The MEC1725 Boundary Scan JTAG ID is shown in [Table 1-1](#).

Note: Must wait a minimum of 35ms after a POR to accurately read the Boundary Scan JTAG ID. Reading the JTAG ID too soon may return a Boundary Scan JTAG ID of 00000000h. This is not a valid ID value.

52.0 ELECTRICAL SPECIFICATIONS

52.1 Maximum Ratings*

*Stresses exceeding those listed could cause permanent damage to the device. This is a stress rating only and functional operation of the device at any other condition above those indicated in the operation sections of this specification is not implied.

Note: When powering this device from laboratory or system power supplies, it is important that the Absolute Maximum Ratings not be exceeded or device failure can result. Some power supplies exhibit voltage spikes on their outputs when the AC power is switched on or off. In addition, voltage transients on the AC power line may appear on the DC output. If this possibility exists, it is suggested that a clamp circuit be used.

52.1.1 ABSOLUTE MAXIMUM THERMAL RATINGS

Parameter	Maximum Limits
Operating Temperature Range	-40°C to +85°C Industrial
Storage Temperature Range	-55° to +150°C
Lead Temperature Range	Refer to JEDEC Spec J-STD-020B

52.1.2 ABSOLUTE MAXIMUM SUPPLY VOLTAGE RATINGS

Symbol	Parameter	Maximum Limits
VBAT	3.0V Battery Backup Power Supply with respect to ground	-0.3V to +3.63V
VTR_REG	Main Regulator Power Supply with respect to ground	-0.3V to +3.63V
VTR_ANALOG	3.3V Analog Power Supply with respect to ground	-0.3V to +3.63V
VTR1	3.3V Power Supply with respect to ground	-0.3V to +3.63V
VTR2	3.3V or 1.8V Power Supply with respect to ground	-0.3V to +3.63V
VTR3	1.8V Power Supply with respect to ground	-0.3V to +1.98V
VCC	3.3V Main Power Supply with respect to ground (Connected to VCC_PWRGD pin)	-0.3V to +3.63V

52.1.3 ABSOLUTE MAXIMUM I/O VOLTAGE RATINGS

Parameter	Maximum Limits
Voltage on any Digital Pin with respect to ground	Determined by Power Supply of I/O Buffer and Pad Type

MEC1725

52.2 Operational Specifications

52.2.1 POWER SUPPLY OPERATIONAL CHARACTERISTICS

TABLE 52-1: POWER SUPPLY OPERATING CONDITIONS

Symbol	Parameter	MIN	TYP	MAX	Units
VBAT	Battery Backup Power Supply	2.0	3.0	3.465	V
VTR_REG	Main Regulator Power Supply	1.71	3.3	3.465	V
VTR_ANALOG	Analog Power Supply	3.135	3.3	3.465	V
VTRx	3.3V Power Supply	3.135	3.3	3.465	V
	1.8V Power Supply	1.71	1.80	1.89	V

Note: The specification for the VTRx supplies are +/- 5%.

52.2.2 AC ELECTRICAL SPECIFICATIONS

The AC Electrical Specifications for the clock input time are defined in [Section 53.7, "Clocking AC Timing Characteristics"](#). The clock rise and fall times use the standard input thresholds of 0.8V and 2.0V unless otherwise specified and the capacitive values listed in this section.

52.2.3 CAPACITIVE LOADING SPECIFICATIONS

The following table defines the maximum capacitive load validated for the buffer characteristics listed in [Table 52-3, "DC Electrical Characteristics"](#) and the AC characteristics defined in [Section 53.7, "Clocking AC Timing Characteristics"](#).

CAPACITANCE $T_A = 25^\circ\text{C}$; $f_c = 1\text{MHz}$; $V_{CC} = 3.3\text{VDC}$

Note: All output pins, except pin under test, tied to AC ground.

TABLE 52-2: MAXIMUM CAPACITIVE LOADING

Parameter	Symbol	Limits			Unit	Notes
		MIN	TYP	MAX		
Input Capacitance of PECL_IO	C_{IN}			10	pF	
Output Load Capacitance supported by PECL_IO	C_{OUT}			10	pF	
Input Capacitance (all other input pins)	C_{IN}			10	pF	Note 1
Output Capacitance (all other output pins)	C_{OUT}			20	pF	Note 2

Note 1: All input buffers can be characterized by this capacitance unless otherwise specified.

2: All output buffers can be characterized by this capacitance unless otherwise specified.

52.2.4 DC ELECTRICAL CHARACTERISTICS FOR I/O BUFFERS

TABLE 52-3: DC ELECTRICAL CHARACTERISTICS

Parameter	Symbol	MIN	TYP	MAX	Units	Comments
PIO-12 Type Buffer						
All PIO-12 Buffers Pull-up Resistor @3.3V @1.8V	R_{PU}	34 35	60 60	95 105	K Ω	Internal PU selected via the GPIO Pin Control Register.
All PIO-12 Buffers Pull-down Resistor @3.3V @1.8V	R_{PD}	38 36	63 63	127 118	K Ω	Internal PD selected via the GPIO Pin Control Register.
PIO-12 IOH at 1.8V for 10pf Load DRIVE_STRENGTH = 00b DRIVE_STRENGTH = 01b DRIVE_STRENGTH = 10b DRIVE_STRENGTH = 11b	— — — —	2.02 4.03 8.06 12.1	3.35 6.7 12.6 20	5.26 10.5 21 31.5	mA mA mA mA	The drive strength is determined by programming bits[5:4] of the Pin Control Register 2 Note 2 Note 2 Note 2 Note 2
PIO-12 IOL at 1.8V for 10pf Load DRIVE_STRENGTH = 00b DRIVE_STRENGTH = 01b DRIVE_STRENGTH = 10b DRIVE_STRENGTH = 11b	— — — —	2.49 5.07 10.1 15.1	4.5 9.16 18.2 27.3	7.40 14.9 29.7 44	mA mA mA mA	The drive strength is determined by programming bits[5:4] of the Pin Control Register 2 Note 2 Note 2 Note 2 Note 2
PIO-12 IOH at 3.3V for 10pf Load DRIVE_STRENGTH = 00b DRIVE_STRENGTH = 01b DRIVE_STRENGTH = 10b DRIVE_STRENGTH = 11b	— — — —	4.04 8.01 16 24	6 12 21 35.8	8.58 17.1 34.2 51.3	mA mA mA mA	The drive strength is determined by programming bits[5:4] of the Pin Control Register 2 Note 2 Note 2 Note 2 Note 2

MEC1725

TABLE 52-3: DC ELECTRICAL CHARACTERISTICS (CONTINUED)

Parameter	Symbol	MIN	TYP	MAX	Units	Comments
PIO-12 IOL at 3.3V for 10pf Load						The drive strength is determined by programming bits[5:4] of the Pin Control Register 2
DRIVE_STRENGTH = 00b	–	4.77	7.2	10.1	mA	Note 2
DRIVE_STRENGTH = 01b	–	9.63	14.5	20.2	mA	Note 2
DRIVE_STRENGTH = 10b	–	19.2	26.4	40.3	mA	Note 2
DRIVE_STRENGTH = 11b	–	28.7	43.1	60	mA	Note 2
PIO-12 Rising Output Slope (pad)						The drive strength is determined by programming bits[5:4] of the Pin Control Register 2
DRIVE_STRENGTH = 00b	–	4.052	5.853	9.896	ns	For 1.8V at 10pf Load. See Note 2 .
DRIVE_STRENGTH = 01b	–	2.690	3.831	6.370	ns	For 1.8V at 10pf Load. See Note 2 .
DRIVE_STRENGTH = 10b	–	1.679	2.437	4.174	ns	For 1.8V at 10pf Load. See Note 2 .
DRIVE_STRENGTH = 11b	–	1.405	2.016	3.394	ns	For 1.8V at 10pf Load. See Note 2 .
PIO-12 Falling Output Slope (pad)						The drive strength is determined by programming bits[5:4] of the Pin Control Register 2
DRIVE_STRENGTH = 00b	–	2.976	4.511	8.463	ns	For 1.8V at 10pf Load. See Note 2 .
DRIVE_STRENGTH = 01b	–	2.053	3.085	5.607	ns	For 1.8V at 10pf Load. See Note 2 .
DRIVE_STRENGTH = 10b	–	1.282	1.975	3.654	ns	For 1.8V at 10pf Load. See Note 2 .
DRIVE_STRENGTH = 11b	–	1.041	1.606	2.928	ns	For 1.8V at 10pf Load. See Note 2 .
PIO-12 Rising Output Slope (pad)						The drive strength is determined by programming bits[5:4] of the Pin Control Register 2
DRIVE_STRENGTH = 00b	–	2.518	3.482	5.661	ns	For 3.3V at 10pf Load. See Note 2 .
DRIVE_STRENGTH = 01b	–	1.585	2.235	3.642	ns	For 3.3V at 10pf Load. See Note 2 .
DRIVE_STRENGTH = 10b	–	0.953	1.366	2.276	ns	For 3.3V at 10pf Load. See Note 2 .
DRIVE_STRENGTH = 11b	–	0.746	1.084	1.824	ns	For 3.3V at 10pf Load. See Note 2 .

TABLE 52-3: DC ELECTRICAL CHARACTERISTICS (CONTINUED)

Parameter	Symbol	MIN	TYP	MAX	Units	Comments
PIO-12 Falling Output Slope (pad)						The drive strength is determined by programming bits[5:4] of the Pin Control Register 2
DRIVE_STRENGTH = 00b	–	2.017	2.809	4.833	ns	For 3.3V at 10pf Load. See Note 2 .
DRIVE_STRENGTH = 01b	–	1.220	1.754	3.082	ns	For 3.3V at 10pf Load. See Note 2 .
DRIVE_STRENGTH = 10b	–	0.679	1.008	1.837	ns	For 3.3V at 10pf Load. See Note 2 .
DRIVE_STRENGTH = 11b	–	0.498	0.715	1.404	ns	For 3.3V at 10pf Load. See Note 2 .
I Type Input Buffer						TTL Compatible Schmitt Trigger Input
Low Input Level	V_{IL}			0.3x VTR	V	
High Input Level	V_{IH}		0.7x VTR		V	
Schmitt Trigger Hysteresis	V_{HYS}		400		mV	
O-2 mA Type Buffer						
Low Output Level	V_{OL}			0.4	V	$I_{OL} = 2 \text{ mA (max)}$
High Output Level	V_{OH}	VTR - 0.4			V	$I_{OH} = -2 \text{ mA (min)}$
IO-2 mA Type Buffer	–				–	Same characteristics as an I and an O-2mA.
OD-2 mA Type Buffer						
Low Output Level	V_{OL}			0.4	V	$I_{OL} = 2 \text{ mA (min)}$
IOD-2 mA Type Buffer	–				–	Same characteristics as an I and an OD-2mA.
O-4 mA Type Buffer						
Low Output Level	V_{OL}			0.4	V	$I_{OL} = 4 \text{ mA (max)}$
High Output Level	V_{OH}	VTR - 0.4			V	$I_{OH} = -4 \text{ mA (min)}$
IO-4 mA Type Buffer	–				–	Same characteristics as an I and an O-4mA.
OD-4 mA Type Buffer						
Low Output Level	V_{OL}			0.4	V	$I_{OL} = 4 \text{ mA (min)}$

MEC1725

TABLE 52-3: DC ELECTRICAL CHARACTERISTICS (CONTINUED)

Parameter	Symbol	MIN	TYP	MAX	Units	Comments
IOD-4 mA Type Buffer	–				–	Same characteristics as an I and an OD-4mA.
O-8 mA Type Buffer						
Low Output Level	V_{OL}			0.4	V	$I_{OL} = 8 \text{ mA (max)}$
High Output Level	V_{OH}	VTR - 0.4			V	$I_{OH} = -8 \text{ mA (min)}$
IO-8 mA Type Buffer	–				–	Same characteristics as an I and an O-8mA.
OD-8 mA Type Buffer						
Low Output Level	V_{OL}			0.4	V	$I_{OL} = 8 \text{ mA (min)}$
IOD-8 mA Type Buffer	–				–	Same characteristics as an I and an OD-8mA.
O-12 mA Type Buffer						
Low Output Level	V_{OL}			0.4	V	$I_{OL} = 12\text{mA (max)}$
High Output Level	V_{OH}	VTR - 0.4			V	$I_{OH} = -12\text{mA (min)}$
IO-12 mA Type Buffer	–				–	Same characteristics as an I and an O-12mA.
OD-12 mA Type Buffer						
Low Output Level	V_{OL}			0.4	V	$I_{OL} = 12\text{mA (min)}$
IOD-12 mA Type Buffer	–				–	Same characteristics as an I and an OD-12mA.
PIO-24 Type Buffer						
All PIO-24 Buffers						Internal PU selected via the GPIO Pin Control Register.
Pull-up Resistor @3.3V @1.8V	R_{PU}	34 35	60 60	95 105	K Ω	
All PIO-24 Buffers						Internal PD selected via the GPIO Pin Control Register.
Pull-down Resistor @3.3V @1.8V	R_{PD}	38 36	63 63	127 118	K Ω	

TABLE 52-3: DC ELECTRICAL CHARACTERISTICS (CONTINUED)

Parameter	Symbol	MIN	TYP	MAX	Units	Comments
PIO-24 IOH at 1.8V for 10pf Load						The drive strength is determined by programming bits[5:4] of the Pin Control Register 2
DRIVE_STRENGTH = 00b	–	4.03	6.32	10.5	mA	Note 2
DRIVE_STRENGTH = 01b	–	8.05	12.6	20.9	mA	Note 2
DRIVE_STRENGTH = 10b	–	16.1	25.2	41.9	mA	Note 2
DRIVE_STRENGTH = 11b	–	24.1	37.8	62.6	mA	Note 2
PIO-24 IOL at 1.8V for 10pf Load						The drive strength is determined by programming bits[5:4] of the Pin Control Register 2
DRIVE_STRENGTH = 00b	–	4.87	7.92	14.6	mA	Note 2
DRIVE_STRENGTH = 01b	–	10.1	18.3	29.7	mA	Note 2
DRIVE_STRENGTH = 10b	–	20	32.3	59	mA	Note 2
DRIVE_STRENGTH = 11b	–	30.1	54.3	88.4	mA	Note 2
PIO-24 IOH at 3.3V for 10pf Load						The drive strength is determined by programming bits[5:4] of the Pin Control Register 2
DRIVE_STRENGTH = 00b	–	8.07	10.8	17.1	mA	Note 2
DRIVE_STRENGTH = 01b	–	16	23.8	34.2	mA	Note 2
DRIVE_STRENGTH = 10b	–	32	47.6	68.1	mA	Note 2
DRIVE_STRENGTH = 11b	–	47	71.1	101	mA	Note 2
PIO-24 IOL at 3.3V for 10pf Load						The drive strength is determined by programming bits[5:4] of the Pin Control Register 2
DRIVE_STRENGTH = 00b	–	9.4	14.3	19.9	mA	Note 2
DRIVE_STRENGTH = 01b	–	19.2	28.8	40.2	mA	Note 2
DRIVE_STRENGTH = 10b	–	38.2	57.4	80	mA	Note 2
DRIVE_STRENGTH = 11b	–	57.2	85.9	119	mA	Note 2

MEC1725

TABLE 52-3: DC ELECTRICAL CHARACTERISTICS (CONTINUED)

Parameter	Symbol	MIN	TYP	MAX	Units	Comments
PIO-24 Rising Output Slope (pad)						The drive strength is determined by programming bits[5:4] of the Pin Control Register 2
DRIVE_STRENGTH = 00b	–	3.266	4.620	7.552	ns	For 1.8V at 10pf Load. See Note 2 .
DRIVE_STRENGTH = 01b	–	2.615	3.714	6.033	ns	For 1.8V at 10pf Load. See Note 2 .
DRIVE_STRENGTH = 10b	–	1.795	2.654	4.641	ns	For 1.8V at 10pf Load. See Note 2 .
DRIVE_STRENGTH = 11b	–	1.600	2.378	4.002	ns	For 1.8V at 10pf Load. See Note 2 .
PIO-24 Falling Output Slope (pad)						The drive strength is determined by programming bits[5:4] of the Pin Control Register 2
DRIVE_STRENGTH = 00b	–	2.454	3.688	6.675	ns	For 1.8V at 10pf Load. See Note 2 .
DRIVE_STRENGTH = 01b	–	1.946	2.999	5.329	ns	For 1.8V at 10pf Load. See Note 2 .
DRIVE_STRENGTH = 10b	–	1.322	2.110	3.894	ns	For 1.8V at 10pf Load. See Note 2 .
DRIVE_STRENGTH = 11b	–	1.103	1.796	3.258	ns	For 1.8V at 10pf Load. See Note 2 .
PIO-24 Rising Output Slope (pad)						The drive strength is determined by programming bits[5:4] of the Pin Control Register 2
DRIVE_STRENGTH = 00b	–	1.781	2.590	4.288	ns	For 3.3V at 10pf Load. See Note 2 .
DRIVE_STRENGTH = 01b	–	1.273	1.872	3.189	ns	For 3.3V at 10pf Load. See Note 2 .
DRIVE_STRENGTH = 10b	–	0.855	1.256	2.180	ns	For 3.3V at 10pf Load. See Note 2 .
DRIVE_STRENGTH = 11b	–	0.711	1.048	1.822	ns	For 3.3V at 10pf Load. See Note 2 .

TABLE 52-3: DC ELECTRICAL CHARACTERISTICS (CONTINUED)

Parameter	Symbol	MIN	TYP	MAX	Units	Comments
PIO-24 Falling Output Slope (pad)						The drive strength is determined by programming bits[5:4] of the Pin Control Register 2
DRIVE_STRENGTH = 00b	–	1.373	2.023	3.617	ns	For 3.3V at 10pf Load. See Note 2 .
DRIVE_STRENGTH = 01b	–	0.884	1.339	2.552	ns	For 3.3V at 10pf Load. See Note 2 .
DRIVE_STRENGTH = 10b	–	0.538	0.821	1.618	ns	For 3.3V at 10pf Load. See Note 2 .
DRIVE_STRENGTH = 11b	–	0.417	0.641	1.262	ns	For 3.3V at 10pf Load. See Note 2 .
I Type Input Buffer						TTL Compatible Schmitt Trigger Input
Low Input Level	V_{IL}			0.3x VTR	V	
High Input Level	V_{IH}		0.7x VTR		V	
Schmitt Trigger Hysteresis	V_{HYS}		400		mV	
O-4 mA Type Buffer						
Low Output Level	V_{OL}			0.4	V	$I_{OL} = 4 \text{ mA (max)}$
High Output Level	V_{OH}	VTR - 0.4			V	$I_{OH} = -4 \text{ mA (min)}$
IO-4 mA Type Buffer	–				–	Same characteristics as an I and an O-4mA.
OD-4 mA Type Buffer						
Low Output Level	V_{OL}			0.4	V	$I_{OL} = 4 \text{ mA (min)}$
IOD-4 mA Type Buffer	–				–	Same characteristics as an I and an OD-4mA.
O-8 mA Type Buffer						
Low Output Level	V_{OL}			0.4	V	$I_{OL} = 8 \text{ mA (max)}$
High Output Level	V_{OH}	VTR - 0.4			V	$I_{OH} = -8 \text{ mA (min)}$
IO-8 mA Type Buffer	–				–	Same characteristics as an I and an O-8mA.
OD-8 mA Type Buffer						
Low Output Level	V_{OL}			0.4	V	$I_{OL} = 8 \text{ mA (min)}$

MEC1725

TABLE 52-3: DC ELECTRICAL CHARACTERISTICS (CONTINUED)

Parameter	Symbol	MIN	TYP	MAX	Units	Comments
IOD-8 mA Type Buffer	–				–	Same characteristics as an I and an OD-8mA.
O-16 mA Type Buffer						
Low Output Level	V_{OL}			0.4	V	$I_{OL} = 16 \text{ mA (max)}$
High Output Level	V_{OH}	VTR - 0.4			V	$I_{OH} = -16 \text{ mA (min)}$
IO-16 mA Type Buffer	–				–	Same characteristics as an I and an O-16mA.
OD-16 mA Type Buffer						
Low Output Level	V_{OL}			0.4	V	$I_{OL} = 16 \text{ mA (min)}$
IOD-16 mA Type Buffer	–				–	Same characteristics as an I and an OD-16mA.
O-24 mA Type Buffer						
Low Output Level	V_{OL}			0.4	V	$I_{OL} = 24 \text{ mA (max)}$
High Output Level	V_{OH}	VTR - 0.4			V	$I_{OH} = -24 \text{ mA (min)}$
IO-24 mA Type Buffer	–				–	Same characteristics as an I and an O-24mA.
OD-24 mA Type Buffer						
Low Output Level	V_{OL}			0.4	V	$I_{OL} = 24 \text{ mA (min)}$
IOD-24 mA Type Buffer	–				–	Same characteristics as an I and an OD-24mA.
I_AN Type Buffer						
I_AN Type Buffer (Analog Input Buffer)	I_AN					Voltage range on pins: -0.3V to +3.63V These buffers are not 5V tolerant buffers and they are not back-drive protected

TABLE 52-3: DC ELECTRICAL CHARACTERISTICS (CONTINUED)

Parameter	Symbol	MIN	TYP	MAX	Units	Comments
PECI Type Buffer						
VREF_VTT						Connects to CPU Voltage pin (Processor dependent)
PECI Bus Voltage	V _{BUS}	0.95		1.26	V	
SBTSI Bus Voltage	V _{BUS}	1.28		1.9	V	
Input current	IDC			100	μA	
Input Low Current	ILEAK	-10		+10	μA	This buffer is not 5V tolerant This buffer is not backdrive protected.
PECI_IO						All input and output voltages are a function of Vref, which is connected to CPU_VREF input. See Peci Specification.
Input voltage range	V _{In}	-0.3		+Vref 0.3	V	
Hysteresis	V _{HYS}	0.1 ×Vref	0.2×V ref		V	
Low Input Level	V _{IL}			0.275 ×Vref	V	
High Input Level	V _{IH}	0.725 ×Vref			V	
Low Output Level	V _{OL}			0.25× Vref	V	0.5mA < IOL < 1mA
High Output Level	V _{OH}	0.75 ×Vref			V	IOH = -6mA
Tolerance				3.63	V	This buffer is not 5V tolerant This buffer is not backdrive protected.
Crystal Oscillator						
XTAL1 (ICLK)	The MEC1725 crystal oscillator design requires a 32.768 KHz parallel resonant crystal with load caps in the range 4-18pF. Refer to "Application Note PCB Layout Guide for MEC1725" for more information.					
XTAL2 (OCLK)						
Low Input Level	V _{ILI}			0.4	V	
High Input Level	V _{ILH}	2.0			V	VIN = 0 to VTR

MEC1725

TABLE 52-3: DC ELECTRICAL CHARACTERISTICS (CONTINUED)

Parameter	Symbol	MIN	TYP	MAX	Units	Comments
ADC Reference Pins						
ADC_VREF						
Voltage (Option A)	V		VTR		V	Connect to same power supply as VTR
Voltage (Option B)	V	2.97	3.0	3.03	V	•
Input Impedance	R _{REF}		75		KΩ	
Input Low Current	ILEAK	-0.05		+0.05	μA	This buffer is not 5V tolerant This buffer is not backdrive protected.
eSPI Pins						
All IO-24 Buffers Pull-up Resistor @1.8V	R _{PU}	35	60	105	KΩ	Internal PU selected via the GPIO Pin Control Register.
All PIO-12 Buffers Pull-down Resistor @1.8V	R _{PD}	36	63	118	KΩ	Internal PD selected via the GPIO Pin Control Register.
IO-24 IOH at 1.8V for 10pf Load						The drive strength is determined by programming bits[5:4] of the Pin Control Register 2
DRIVE_STRENGTH = 00b	–	8.42	12.8	19	mA	Note 2
DRIVE_STRENGTH = 01b	–	8.42	12.8	19	mA	Note 2
DRIVE_STRENGTH = 10b	–	16.8	25.6	38	mA	Note 2
DRIVE_STRENGTH = 11b	–	25.2	38.4	56.9	mA	Note 2
IO-24 IOL at 1.8V for 10pf Load						The drive strength is determined by programming bits[5:4] of the Pin Control Register 2
DRIVE_STRENGTH = 00b	–	8.1	13.5	22	mA	Note 2
DRIVE_STRENGTH = 01b	–	8.1	13.5	22	mA	Note 2
DRIVE_STRENGTH = 10b	–	16.5	27.2	44.4	mA	Note 2
DRIVE_STRENGTH = 11b	–	24.8	40.8	66.5	mA	Note 2

TABLE 52-3: DC ELECTRICAL CHARACTERISTICS (CONTINUED)

Parameter	Symbol	MIN	TYP	MAX	Units	Comments
IO-24 Rising Output Slope (pad)						The drive strength is determined by programming bits[5:4] of the Pin Control Register 2
DRIVE_STRENGTH = 00b	–	0.931	1.413	3.162	ns	For 1.8V at 10pf Load. See Note 2 .
DRIVE_STRENGTH = 01b	–	0.924	1.408	2.394	ns	For 1.8V at 10pf Load. See Note 2 .
DRIVE_STRENGTH = 10b	–	0.554	0.821	1.35	ns	For 1.8V at 10pf Load. See Note 2 .
DRIVE_STRENGTH = 11b	–	0.416	0.622	1.009	ns	For 1.8V at 10pf Load. See Note 2 .
IO-24 Falling Output Slope (pad)						The drive strength is determined by programming bits[5:4] of the Pin Control Register 2
DRIVE_STRENGTH = 00b	–	0.77	1.218	2.206	ns	For 1.8V at 10pf Load. See Note 2 .
DRIVE_STRENGTH = 01b	–	0.765	1.207	2.17	ns	For 1.8V at 10pf Load. See Note 2 .
DRIVE_STRENGTH = 10b	–	0.465	0.718	1.293	ns	For 1.8V at 10pf Load. See Note 2 .
DRIVE_STRENGTH = 11b	–	0.364	0.558	0.892	ns	For 1.8V at 10pf Load. See Note 2 .
I Type Input Buffer						TTL Compatible Schmitt Trigger Input
Low Input Level	V_{IL}	-0.3		0.3x VTR	V	
High Input Level	V_{IH}	0.7x VTR		VTR + 0.3	V	
Schmitt Trigger Hysteresis	V_{HYS}		400		mV	
O-8 mA Type Buffer						
Low Output Level	V_{OL}			0.4	V	$I_{OL} = 8 \text{ mA (max)}$
High Output Level	V_{OH}	VTR - 0.4			V	$I_{OH} = -8 \text{ mA (min)}$
IO-8 mA Type Buffer	–				–	Same characteristics as an I and an O-8mA.
OD-8 mA Type Buffer						
Low Output Level	V_{OL}			0.4	V	$I_{OL} = 8 \text{ mA (min)}$
IOD-8 mA Type Buffer	–				–	Same characteristics as an I and an OD-8mA.

MEC1725

TABLE 52-3: DC ELECTRICAL CHARACTERISTICS (CONTINUED)

Parameter	Symbol	MIN	TYP	MAX	Units	Comments
O-16 mA Type Buffer						
Low Output Level	V_{OL}			0.4	V	$I_{OL} = 16 \text{ mA (max)}$
High Output Level	V_{OH}	VTR - 0.4			V	$I_{OH} = -16 \text{ mA (min)}$
IO-16 mA Type Buffer	–				–	Same characteristics as an I and an O-16mA.
OD-16 mA Type Buffer						
Low Output Level	V_{OL}			0.4	V	$I_{OL} = 16 \text{ mA (min)}$
IOD-16 mA Type Buffer	–				–	Same characteristics as an I and an OD-16mA.
O-24 mA Type Buffer						
Low Output Level	V_{OL}			0.4	V	$I_{OL} = 24 \text{ mA (max)}$
High Output Level	V_{OH}	VTR - 0.4			V	$I_{OH} = -24 \text{ mA (min)}$
IO-24 mA Type Buffer	–				–	Same characteristics as an I and an O-24mA.
OD-24 mA Type Buffer						
Low Output Level	V_{OL}			0.4	V	$I_{OL} = 24 \text{ mA (min)}$
IOD-24 mA Type Buffer	–				–	Same characteristics as an I and an OD-24mA.
<p>Note 1: Tolerance for the pins are not 5VT Unless the pin chapter explicitly indicates specific pin has “Over-voltage protection” feature.</p> <p>2: These values are guaranteed by design and not tested in production test.</p>						

52.2.4.1 Pin Leakage

Leakage characteristics for all digital I/O pins is shown in the following Pin Leakage table, unless otherwise specified. Two exceptions are pins with Over-voltage protection and Backdrive protection. Leakage characteristics for Over-Voltage protected pins and Backdrive protected pins are shown in the two sub-sections following the Pin Leakage table.

TABLE 52-4: PIN LEAKAGE (VTR=3.3V + 5%; VTR = 1.8V +5%)

(TA = -40°C to +85°C)						
Leakage Current	I_{IL}			+/-2	µA	VIN=0V to VTR

OVER-VOLTAGE PROTECTION TOLERANCE

Note: 5V tolerant pins have both backdrive protection and over-voltage protection.

All the I/O buffers that do not have “Over-voltage Protection” are can only tolerate up to +/-10% I/O operation (or +1.98V when powered by 1.8V, or 3.63V when powered by 3.3V).

Functional pins that have “Over-voltage Protection” can tolerate up to 3.63V when powered by 1.8V, or 5.5V when powered by 3.3V. These pins are also backdrive protected. Backdrive Protection characteristics are shown in the following table:

TABLE 52-5: 5V TOLERANT LEAKAGE CURRENTS (VTR = 3.3V-5%)

(TA = -40°C to +85°C)						
Three-State Input Leakage Current for 5V Tolerant Pins	I _{IL}	-	-	+/-2	μA	VIN = 0 to 5.5V

Note: These measurements are done without an external pull-up.

TABLE 52-6: 3.6V TOLERANT LEAKAGE CURRENTS (VTR = 1.8V-5%)

(TA = -40°C to +85°C)						
Three-State Input Leakage Current for Under-Voltage Tolerant Pins	I _{IL}	-	-	+/-2	μA	VIN=0 to 3.6V

Note: This measurements are done without an external pull-up.

BACKDRIVE PROTECTION

TABLE 52-7: BACKDRIVE PROTECTION LEAKAGE CURRENTS (VTR=0V)

(TA = -40°C to +85°C)						
Input Leakage	I _{IL}			+/-3	μA	0V < VIN ≤ 5.5V

52.2.5 ADC ELECTRICAL CHARACTERISTICS

TABLE 52-8: ADC CHARACTERISTICS

Symbol	Parameter	MIN	TYP	MAX	Units	Comments
VTR_ANALOG	Analog Supply Voltage (powered by VTR)	3.135	3.3	3.465	V	
V _{RNG}	Input Voltage Range	0		VREF_ADC	V	Range of VREF_ADC input to ADC ground

MEC1725

TABLE 52-8: ADC CHARACTERISTICS (CONTINUED)

Symbol	Parameter	MIN	TYP	MAX	Units	Comments
RES	Resolution	–	–	10/12	Bits	Guaranteed Monotonic
ACC	Absolute Accuracy	–	2	4	LSB	
DNL	Differential Non Linearity, DNL	-1	–	+1	LSB	Guaranteed Monotonic
INL	Integral Non Linearity, INL	-3.0	–	+3	LSB	Guaranteed Monotonic
EGAIN	Gain Error, E _{GAIN}	-2	–	2	LSB	
E _{OFFSET}	Offset Error, E _{OFFSET}	-2	–	2	LSB	
CONV	Conversion Time		1.125		μS/channel	
II	Input Impedance	4	4.5	5.3	MΩ	

52.2.6 THERMAL CHARACTERISTICS

TABLE 52-9: THERMAL OPERATING CONDITIONS

Rating	Symbol	MIN	TYP	MAX	Unit
Consumer Temperature Devices					
Operating Junction Temperature Range	T _J		—	125	°C
Operating Ambient Temperature Range - Industrial	T _A	-40	—	+85	°C
Power Dissipation: Internal Chip Power Dissipation: P _{INT} = V _{DD} x (I _{DD} – S I _{OH}) I/O Pin Power Dissipation: I/O = S ((V _{DD} – V _{OH}) x I _{OH}) + S (V _{OL} x I _{OL})	P _D		69.3 (P _{INT} + P _{I/O})		mW
Maximum Allowed Power Dissipation a. T _J Max value is at ambient of 70°C	P _D MAX		(T _J ^a – T _A)/θ _{JA}		W

TABLE 52-10: THERMAL PACKAGING CHARACTERISTICS

Characteristics	Symbol	TYP	MAX	Unit	Part #
Package Thermal Resistance, 176-pin WFBGA	θ _{JA}	35.2	—	°C/W	MEC1725
	θ _{JC}	10.9	—	°C/W	
Package Thermal Resistance, 176-pin WFBGA	θ _{JA}	35.2	—	°C/W	MEC1723
	θ _{JC}	10.9	—	°C/W	
Package Thermal Resistance, 176-pin WFBGA	θ _{JA}	44.1	—	°C/W	MEC1721
	θ _{JC}	15.0	—	°C/W	
Note: Junction to ambient thermal resistance, Theta-JA (θ _{JA}), and Junction to case thermal resistance, Theta-JC (θ _{JC}), numbers are achieved by package simulations.					

52.3 Power Consumption

TABLE 52-11: VTR SUPPLY CURRENT, I_VTR

VCC	VTR	96 MHz Clock	VTR1			VTR2			VTR3			Units	Comments
			Typical I (3.3V, 25C)	Max (3.45V, 70C)	Max (3.45V, 85C)	Typical I (3.3V, 25C)	Max (3.45V, 70C)	Max (3.45V, 85C)	Typical (1.80V, 25C)	Max (1.89V, 70C)	Max (1.89V, 85C)		
On	On	96MHz	1.40	1.50	1.50	0.01	0.01	0.01	0.01	0.01	0.02	mA	Full On
On	On	PLL Gated	0.15	0.15	0.15	0.01	0.01	0.01	0.01	0.01	0.02	mA	Light Sleep
On	On	PLL Off	0.10	0.10	0.10	0.01	0.01	0.01	0.01	0.01	0.02	mA	Heavy Sleep
Off	On	96MHz	1.50	1.50	1.50	0.01	0.01	0.01	0.01	0.01	0.02	mA	Full On
Off	On	PLL Gated	0.15	0.15	0.15	0.01	0.01	0.01	0.01	0.01	0.02	mA	Light Sleep
Off	On	PLL Off	0.10	0.10	0.10	0.01	0.01	0.01	0.01	0.01	0.02	mA	Heavy Sleep

TABLE 52-12: VTR SUPPLY CURRENT, I_VTR

VCC	VTR	96 MHz Clock	VTR_REG			VTR_PLL			VTR_ANALOG			Units	Comments
			Typical I (3.3V, 25C)	Max (3.45V, 70C)	Max (3.45V, 85C)	Typical I (3.3V, 25C)	Max (3.45V, 70C)	Max (3.45V, 85C)	Typical (3.3V, 25C)	Max (3.45V, 70C)	Max (3.45V, 85C)		
On	On	96MHz	15.00	21.00	25.00	0.10	0.11	0.12	0.90	1.00	1.00	mA	Full On
On	On	PLL Gated	3.00	9.00	12.00	0.10	0.11	0.12	0.40	0.45	0.45	mA	Light Sleep
On	On	PLL Off	2.00	6.00	10.00	0.01	0.01	0.01	0.30	0.35	0.35	mA	Heavy Sleep
Off	On	96MHz	15.00	21.00	25.00	0.10	0.11	0.12	0.90	1.00	1.00	mA	Full On
Off	On	PLL Gated	3.00	9.00	12.00	0.10	0.11	0.12	0.40	0.45	0.45	mA	Light Sleep
Off	On	PLL Off	2.00	6.00	10.00	0.01	0.01	0.01	0.30	0.35	0.35	mA	Heavy Sleep

Note 1: Full On is defined as follows: The processor is not sleeping, the PLL is powered and the following blocks are Active: ADC, EC Subsystem, Hibernation Timer, Interrupt Controller, PWM, TFDP, Basic Timers, JTAG, RTC. The following blocks are Idle: PECl, eSPI.

- 2:** The sleep states are defined in the System Sleep Control Register in the Power, Clocks and Resets Chapter.
- 3:** In order to achieve the lowest leakage current when both PECl and SB TSI are not used, set the VREF_VTT Disable bit to 1.
- 4:** In order to achieve the lowest leakage current when the VREF_VTT power domain is not required, ground the VREF_VTT pin.
- 5:** All values are taken with no eSPI traffic and ADC disabled.
- 6:** VCC on/off is determined by VCC_PWRGD pin.

MEC1725

TABLE 52-13: ADDITIONAL VTR SUPPLY CURRENT WITH VARIOUS BLOCKS ENABLED

VCC	VTR	96 MHz Clock	VTR1			VTR_ANALOG			Units	Comments
			Typical (3.3V, 25C)	Max (3.45V, 70C)	Max (3.45V, 85C)	Typical (3.3V, 25C)	Max (3.45V, 70C)	Max (3.45V, 85C)		
On/Off	On	96MHz				0.45	0.50	0.50	mA	Additional IVTR with ADC enabled

Note 1: The values in this table are added to the values in [VTR Supply Current, I_VTR](#) excluding the sleep states.

TABLE 52-14: ADDITIONAL VTR SUPPLY CURRENT WITH ESPI ENABLED

VCC	VTR	96 MHz Clock	VTR_REG			VTR3			Units	Comments
			Typical (3.3V, 25C)	Max (3.45V, 70C)	Max (3.45V, 85C)	Typical (1.8V, 25C)	Max (1.89V, 70C)	Max (1.89V, 85C)		
On/Off	On	96MHz	0.30	0.30	0.30	0.01	0.01	0.01	mA	eSPI Traffic (eSPI Clock at 66MHz)

Note 1: The values in this table are added to the values in [VTR Supply Current, I_VTR](#) excluding the sleep states.

TABLE 52-15: VBAT SUPPLY CURRENT, I_VBAT (VBAT=3.0V)

VCC	VTR	96 MHz	Typical (3.0V, 25° C)	Max (3.0V, 25° C)	Units	Comments
Off	On	Off	5.0	6.0	mA	Internal 32kHz oscillator - add to VTR power well that supplies this current through the diode or is connected to the VBAT pin. This is not from the coin cell.
Off	Off	Off	4.0	16.0	uA	32kHz crystal oscillator
Off	Off	Off	4.0	16.0	uA	External 32kHz clock on XTAL2 pin- Running
Off	Off	Off	4.0	16.0	mA	External 32kHz clock on XTAL2 pin -Low
Off	Off	Off	4.0	16.0	uA	External 32kHz clock on SUSCLK_IN pin-Running
Off	Off	Off	4.0	16.0	uA	External 32kHz clock on SUSCLK_IN pin - Low

TABLE 52-16: VBAT SUPPLY CURRENT, I_VBAT (VBAT=3.3V)

VCC	VTR	96 MHz	Typical (3.3V, 25 ⁰ C)	Max (3.3V, 25 ⁰ C)	Units	Comments
Off	Off	Off	4.0	16.0	uA	32kHz crystal oscillator
Off	Off	Off	4.0	16.0	uA	External 32kHz clock on XTAL2 pin -Running
Off	Off	Off	4.0	16.0	mA	External 32kHz clock on XTAL2 pin -Low
Off	Off	Off	4.0	16.0	uA	External 32kHz clock on SUSCLK_IN pin-Running

MEC1725

53.0 TIMING DIAGRAMS

Note: Timing values are preliminary and may change after characterization.

53.1 Power-up and Power-down Timing

FIGURE 53-1: VTR/VBAT POWER-UP TIMING

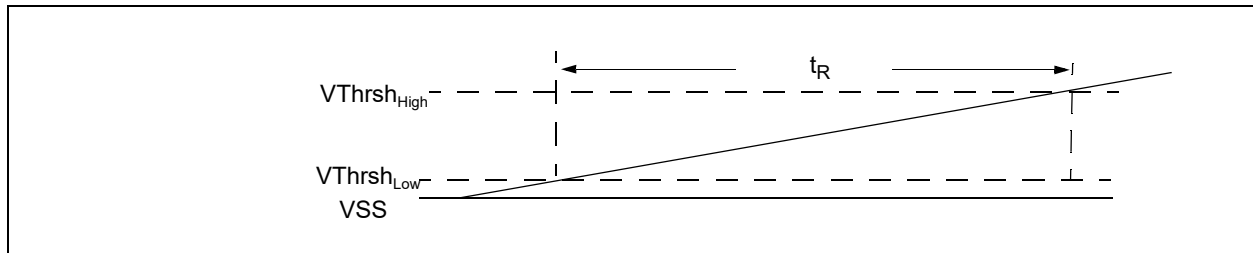

FIGURE 53-2: VTR RESET AND POWER-DOWN

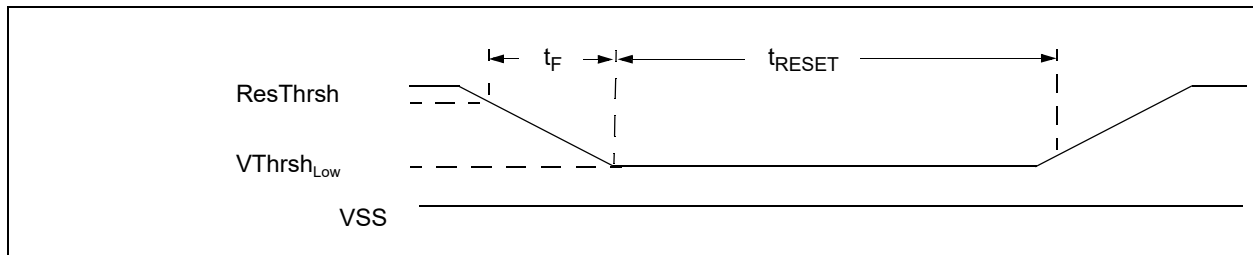

TABLE 53-1: VTR/VBAT TIMING PARAMETERS

Symbol	Parameter	MIN	TYP	MAX	Units	Notes
t_F	VTR Fall time	30			μs	1
	VBAT Fall time	30			μs	
t_R	VTR Rise time	0.050		20	ms	1
	VBAT Rise time	0.100		20	ms	
t_{RESET}	Minimum Reset Time	1			μs	
$V_{\text{Thrsh}_{\text{Low}}}$	VTR Low Voltage Threshold	0.1 x VTR			V	1
	VBAT Low Voltage Threshold	0.1 x VBAT			V	
$V_{\text{Thrsh}_{\text{High}}}$	VTR High Voltage Threshold			0.9 x VTR	V	1
	VBAT High Voltage Threshold			0.9 x VBAT	V	
ResThrsh	VTR Reset Threshold	0.5	1.8	2.7	V	1
	VBAT Reset Threshold	0.5	1.25	1.9	V	

Note 1: VTR applies to both VTR_REG and VTR_ANALOG

53.2 Power Sequencing

FIGURE 53-3: POWER RAIL SEQUENCING

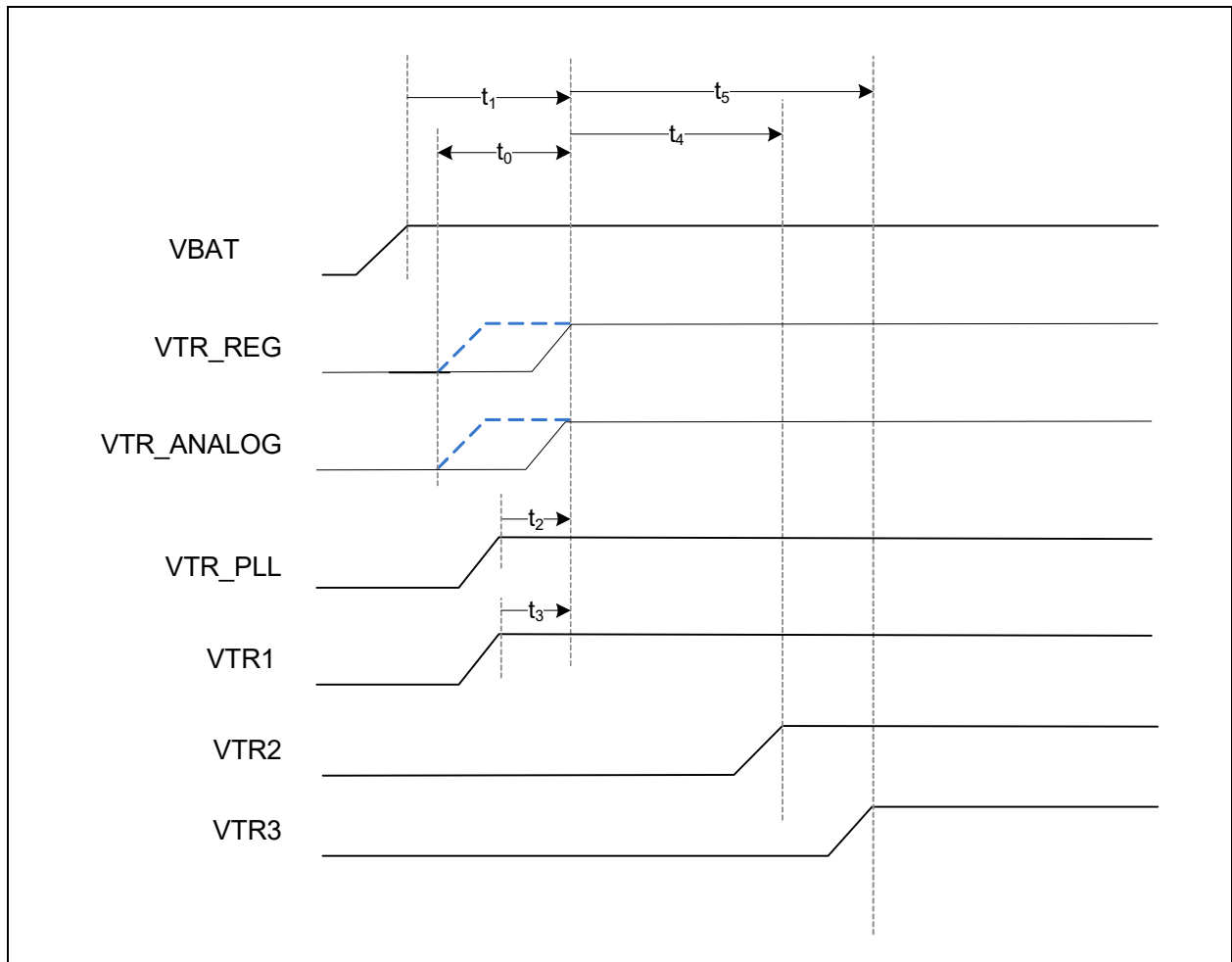

TABLE 53-2: POWER SEQUENCING PARAMETERS

Symbol	Parameter	Min	Typ	Max	Units	Notes
t_0	VTR_ANALOG above minimum operating threshold to VTR_REG above minimum operating threshold	0		1	ms	1, 4
	VTR_REG above minimum operating threshold to VTR_ANALOG above minimum operating threshold	0		1	ms	
t_1	VBAT above minimum operating threshold to VTR_ANALOG and VTR_REG are both above minimum operating thresholds	0			μ s	2

MEC1725

TABLE 53-2: POWER SEQUENCING PARAMETERS (CONTINUED)

Symbol	Parameter	Min	Typ	Max	Units	Notes
t_2	VTR_PLL above minimum operating threshold to VTR_ANALOG above minimum operating threshold			0	ms	3, 4
t_3	VTR_ANALOG and VTR_REG are both above minimum operating thresholds to VTR1 above minimum operating threshold.	0		1	ms	3, 4
t_4	VTR_ANALOG and VTR_REG are both above minimum operating thresholds to VTR2 above minimum operating threshold. VTR2 at 1.8V(nom) or 3.3V(nom)	0		1	ms	3, 4
t_5	FOR ESPI BOOT; VTR3=1.8V VTR_ANALOG and VTR_REG are both above minimum operating thresholds to VTR3 above minimum operating threshold.	0		30	sec	4
	FOR NON-ESPI BOOT; VTR3=1.8 VTR_ANALOG and VTR_REG are both above minimum operating thresholds to VTR3 above minimum operating threshold.	0			ms	4

Note 1: VTR_ANALOG and VTR_REG may ramp in either order

- 2:** VBAT must rise no later than VTR_ANALOG and VTR_REG. This relationship is guaranteed by the recommended battery circuit in the layout guidelines.
- 3:** The SHD_CS# pin, which is powered by VTR2, must be powered before the Boot ROM samples this pin.
- 4:** Minimum operating threshold values for Power Rails are defined in [Table 52-1, "Power Supply Operating Conditions"](#).

Please refer Boot ROM documentation for complete power sequencing options and timing requirements.

53.3 Boot from SPI Flash Timing

Refer to MEC1725 Boot ROM document for the sequence and timing

53.4 Boot from eSPI Timing

Refer to MEC1725 Boot ROM document for the sequence and timing

53.5 VCC_PWRGD Timing

FIGURE 53-4: VCC_PWRGD TIMING

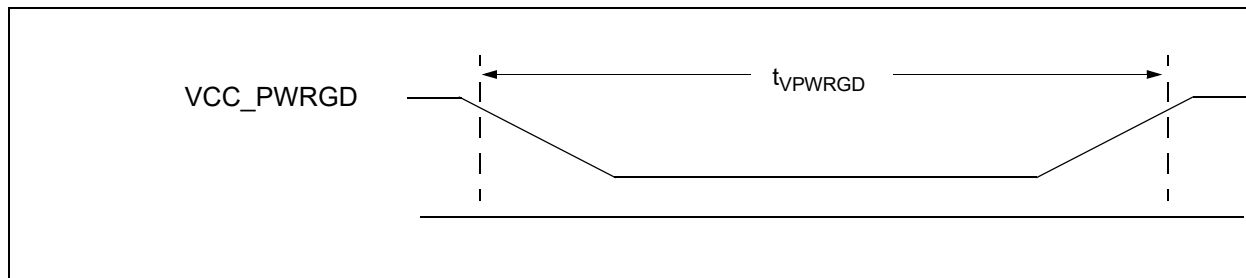

TABLE 53-3: VCC_PWRGD POWER TIMING PARAMETERS

Symbol	Parameter	Limits		Units	Notes
		MIN	MAX		
t_{VPWRGD}	VCC_PWRGD Pulse Width	31		ns	

53.6 nRESET_IN Timing

FIGURE 53-5: NRESET_IN TIMING

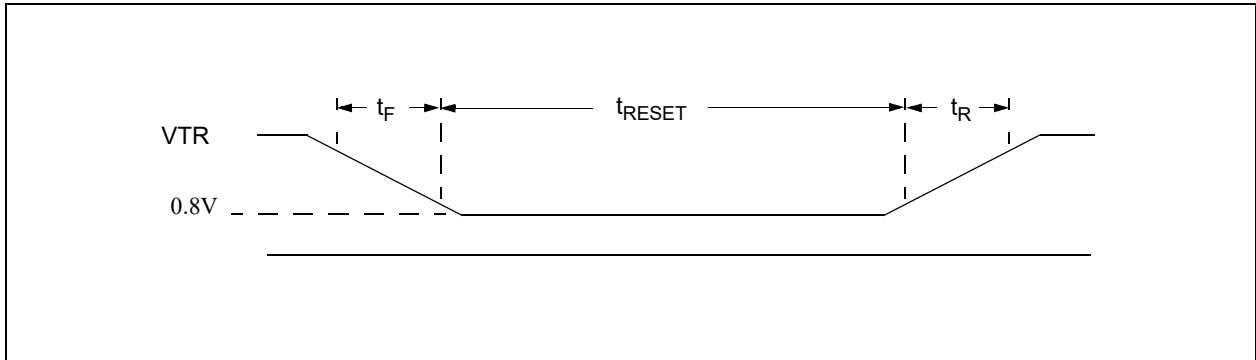

TABLE 53-4: RESETI# TIMING PARAMETERS

Symbol	Parameter	Limits		Units	Comments
		MIN	MAX		
t _F	nRESET_IN Fall time	0	1	ms	
t _R	nRESET_IN Rise time	0	1	ms	
t _{RESET}	Minimum Reset Time	1		μs	Note 1
Note 1: The nRESET_IN input pin can tolerate glitches of no more than 50ns.					

MEC1725

53.7 Clocking AC Timing Characteristics

FIGURE 53-6: CLOCK TIMING DIAGRAM

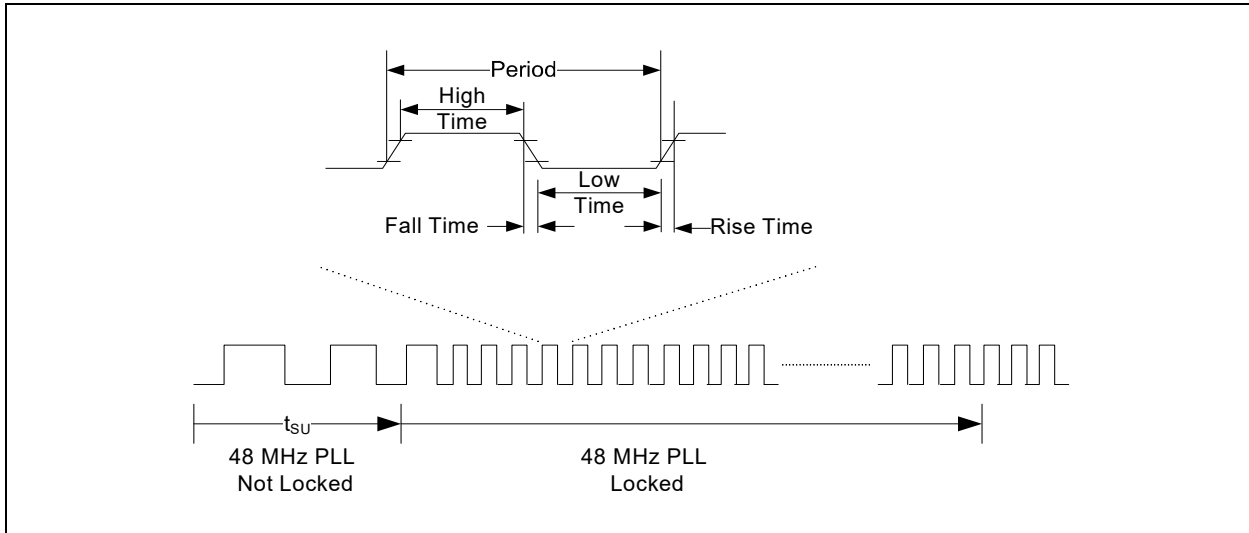

TABLE 53-5: CLOCK TIMING PARAMETERS

Clock	Symbol	Parameters	MIN	TYP	MAX	Units
48 MHz PLL	t_{SU}	Start-up accuracy from power-on-reset and waking from Heavy Sleep (Note 6)	-	-	3	ms
	-	Operating Frequency (locked to 32KHz single-ended input) (Note 1)	47.5	48	48.5	MHz
	-	Operating Frequency (Note 1)	46.56	48	49.44	MHz
	CCJ	Cycle to Cycle Jitter (Note 2)	-200		200	ps
	t_{DO}	Output Duty Cycle	45	-	55	%
32MHz Ring Oscillator	-	Operating Frequency	16	-	48	MHz

Note 1: The 48MHz PLL is frequency accuracy is computed by adding +/-1% to the accuracy of the 32kHz reference clock.

2: The Cycle to Cycle Jitter of the 48MHz PLL is +/-200ps based on an ideal 32kHz clock source. The actual jitter on the 48MHz clock generated is computed by adding the clock jitter of the 32kHz reference clock to the 48MHz PLL jitter (e.g., 32kHz jitter +/- 200ps).

3: See the PCB Layout guide for design requirements and recommended 32.768 kHz Crystal Oscillators.

4: An external single-ended 32KHz clock is required to have an accuracy of +/- 100 ppm.

5: The external single-ended 32KHz clock source may be connected to either the SUSCLK_IN pin or 32KHZ_IN pin.

6: PLL is started, either from waking from the Heavy Sleep mode, or after a Power On Reset

TABLE 53-5: CLOCK TIMING PARAMETERS (CONTINUED)

Clock	Symbol	Parameters	MIN	TYP	MAX	Units
32.768 kHz Crystal Oscillator (Note 3)	-	Operating Frequency	-	32.768	-	kHz
32KHz Silicon Oscillator	-	Operating Frequency	32.112	32.768	33.424	kHz
	-	Start-up delay from 0k Hz to Operating Frequency			150	us
32KHz single-ended input (Note 5)	-	Operating Frequency	-	32.768	-	kHz
	-	Period	(Note 4)	30.52	(Note 4)	μs
	-	High Time	10			us
	-	Low Time	10			us
	-	Fall Time	-	-	1	us
	-	Rise Time	-	-	1	us

Note 1: The 48MHz PLL is frequency accuracy is computed by adding +/-1% to the accuracy of the 32kHz reference clock.

2: The Cycle to Cycle Jitter of the 48MHz PLL is +/-200ps based on an ideal 32kHz clock source. The actual jitter on the 48MHz clock generated is computed by adding the clock jitter of the 32kHz reference clock to the 48MHz PLL jitter (e.g., 32kHz jitter +/- 200ps).

3: See the PCB Layout guide for design requirements and recommended 32.768 kHz Crystal Oscillators.

4: An external single-ended 32KHz clock is required to have an accuracy of +/- 100 ppm.

5: The external single-ended 32KHz clock source may be connected to either the SUSCLK_IN pin or 32KHZ_IN pin.

6: PLL is started, either from waking from the Heavy Sleep mode, or after a Power On Reset

53.8 GPIO Timings

FIGURE 53-7: GPIO TIMING

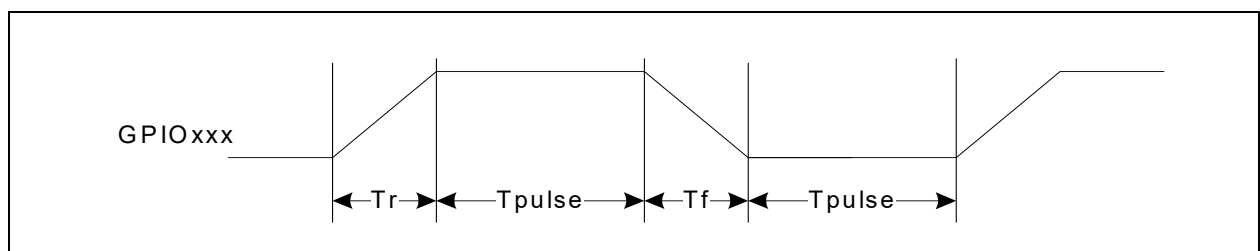

MEC1725

TABLE 53-6: GPIO TIMING PARAMETERS

Symbol	Parameter	MIN	TYP	MAX	Unit	Notes
t_R	GPIO Rise Time (push-pull)	0.54		1.31	ns	1
t_F	GPIO Fall Time	0.52		1.27	ns	
t_R	GPIO Rise Time (push-pull)	0.58		1.46	ns	2
t_F	GPIO Fall Time	0.62		1.48	ns	
t_R	GPIO Rise Time (push-pull)	0.80		2.00	ns	3
t_F	GPIO Fall Time	0.80		1.96	ns	
t_R	GPIO Rise Time (push-pull)	1.02		2.46	ns	4
t_F	GPIO Fall Time	1.07		2.51	ns	
t_{pulse}	GPIO Pulse Width	60			ns	

Note 1: Pad configured for 2ma, CL=2pF
2: Pad configured for 4ma, CL=5pF
3: Pad configured for 8ma, CL=10pF
4: Pad configured for 12ma, CL=20pF

53.9 Serial Port (UART) Data Timing

FIGURE 53-8: SERIAL PORT DATA

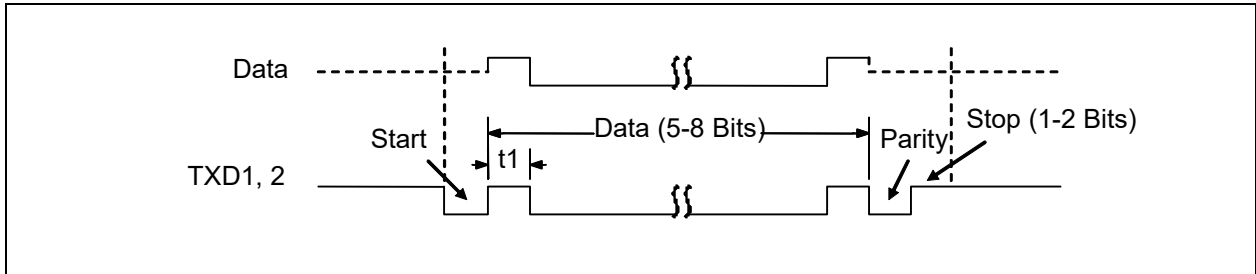

TABLE 53-7: SERIAL PORT DATA PARAMETERS

Name	Description	MIN	TYP	MAX	Units
t1	Serial Port Data Bit Time		t_{BR} (Note 1)		nsec
<p>Note 1: t_{BR} is 1/Baud Rate. The Baud Rate is programmed through the Baud_Rate_Divisor bits located in the Programmable Baud Rate Generator registers. The selectable baud rates are listed in Table 17-8, "UART Baud Rates using Clock Source 1.8432MHz" and Table 17-9, "UART Baud Rates using Clock Source 48MHz". Some of the baud rates have some percentage of error because the clock does not divide evenly. This error can be determined from the values in these baud rate tables.</p>					

MEC1725

53.10 PECl Interface

Name	Description	MIN	MAX	Units	Notes
t_{BIT}	Bit time (overall time evident on PECl pin) Bit time driven by an originator	0.495 0.495	500 250	μ sec μ sec	Note 1
t_{H1}	High level time for logic 1	0.6	0.8	t_{BIT}	Note 2
t_{H0}	High level time for logic 0	0.2	0.4	t_{BIT}	
t_{PEClR}	Rise time (measured from V_{OL} to $V_{IH,min}$, $V_{t(nom)}-5\%$)	-	30 + (5 x #nodes)	ns	Note 3
t_{PEClF}	Fall time (measured from V_{OH} to $V_{IL,max}$, $V_{t(nom)}+5\%$)	-	(30 x #nodes)	ns	Note 3

Note 1: The originator must drive a more restrictive time to allow for quantized sampling errors by a client yet still attain the minimum time less than 500 μ sec. t_{BIT} limits apply equally to t_{BIT-A} and t_{BIT-M} . The MEC1725 is designed to support 2 MHz, or a 500ns bit time. See the PECl 3.0 specification from Intel Corp. for further details.

2: The minimum and maximum bit times are relative to t_{BIT} defined in the Timing Negotiation pulse. See the PECl 3.0 specification from Intel Corp. for further details.

3: “#nodes” is the number of nodes on the PECl bus; host and client nodes are counted as one each. Extended trace lengths may appear as extra nodes. Refer also to [Table 29-2, "PECl Routing Guidelines"](#). See the PECl 3.0 specification from Intel Corp. for further details.

53.11 8042 Emulation CPU_Reset Timing

FIGURE 53-9: KBRST TIMING

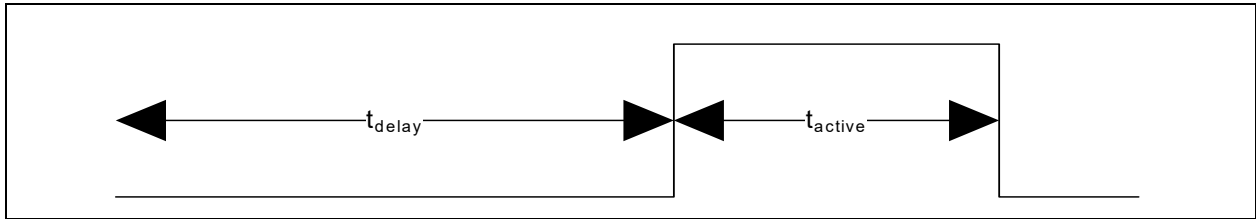

TABLE 53-8: KBRST TIMING PARAMETERS

Name	Description	MIN	TYP	MAX	Units
t_{delay}	Delay prior to active pulse	14	15	15.5	μs
t_{active}	Active pulse width	6	8	8.5	μs

The KBRST pin is the CPU_RESET signal described in [Section 12.10.2, "CPU_RESET Hardware Speed-Up"](#)

53.12 Keyboard Scan Matrix Timing

TABLE 53-9: ACTIVE PRE DRIVE MODE TIMING

Parameter	Symbol	Value			Units	Notes
		MIN	TYP	MAX		
Active Predrive Mode	t_{PREDRIVE}		41.7		ns	

Note: The TYP value is based on two 48 MHz PLL clocks. The MIN and MAX values are dependent on the accuracy of the 48 MHz PLL.

53.13 PS/2 Timing

FIGURE 53-10: PS/2 TRANSMIT TIMING

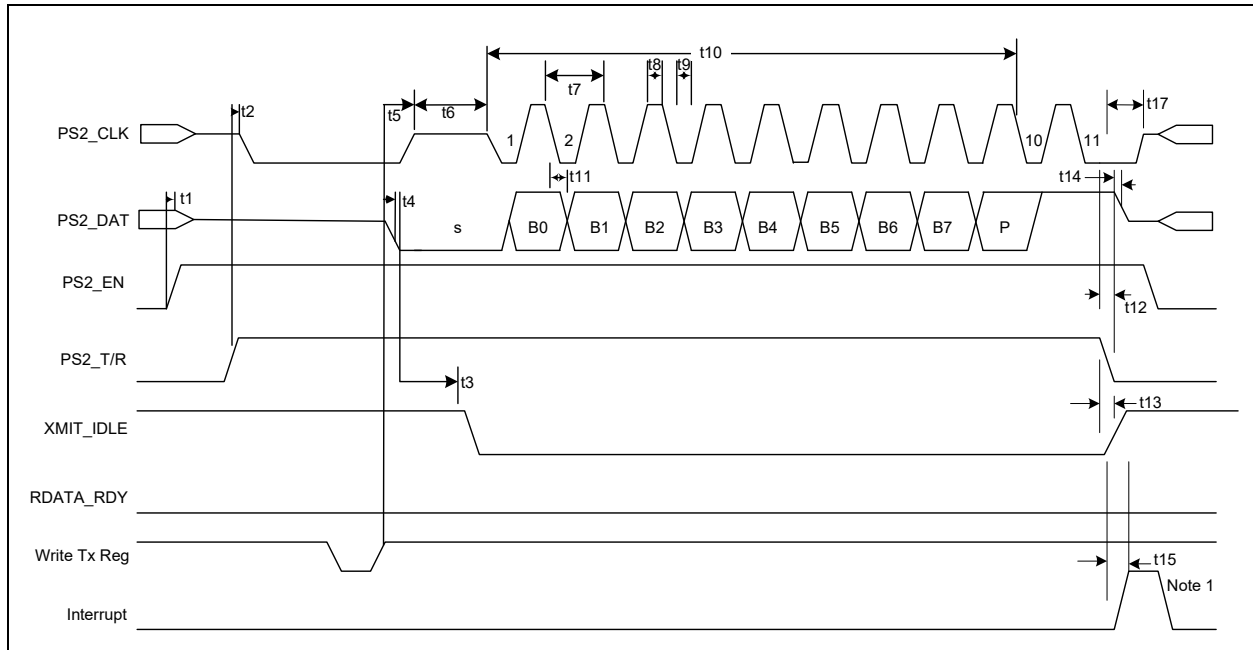

TABLE 53-10: PS/2 CHANNEL TRANSMISSION TIMING PARAMETERS

Name	Description	MIN	TYP	MAX	Units
t1	The PS/2 Channel's CLK and DATA lines are floated following PS2_EN=1 and PS2_T/R=0.			1000	ns
t2	PS2_T/R bit set to CLK driven low preparing the PS/2 Channel for data transmission.				
t3	CLK line floated to XMIT_IDLE bit de-asserted.			1.7	
t4	Trailing edge of WR to Transmit Register to DATA line driven low.	45		90	
t5	Trailing edge of EC WR of Transmit Register to CLK line floated.	90		130	ns
t6	Initiation of Start of Transmit cycle by the PS/2 channel controller to the auxiliary peripheral's responding by latching the Start bit and driving the CLK line low.	0.002		25.003	ms
t7	Period of CLK	60		302	μs
t8	Duration of CLK high (active)	30		151	
t9	Duration of CLK low (inactive)				

MEC1725

TABLE 53-10: PS/2 CHANNEL TRANSMISSION TIMING PARAMETERS (CONTINUED)

Name	Description	MIN	TYP	MAX	Units
t10	Duration of Data Frame. Falling edge of Start bit CLK (1st clk) to falling edge of Parity bit CLK (10th clk).			2.002	ms
t11	DATA output by MEC1725 following the falling edge of CLK. The auxiliary peripheral device samples DATA following the rising edge of CLK.			1.0	μs
t12	Rising edge following the 11th falling clock edge to PS_T/R bit driven low.	3.5		7.1	μs
t13	Trailing edge of PS_T/R to XMIT_IDLE bit asserted.			500	ns
t14	DATA released to high-Z following the PS2_T/R bit going low.				
t15	XMIT_IDLE bit driven high to interrupt generated.				
t17	Trailing edge of CLK is held low prior to going high-Z				

FIGURE 53-11: PS/2 RECEIVE TIMING

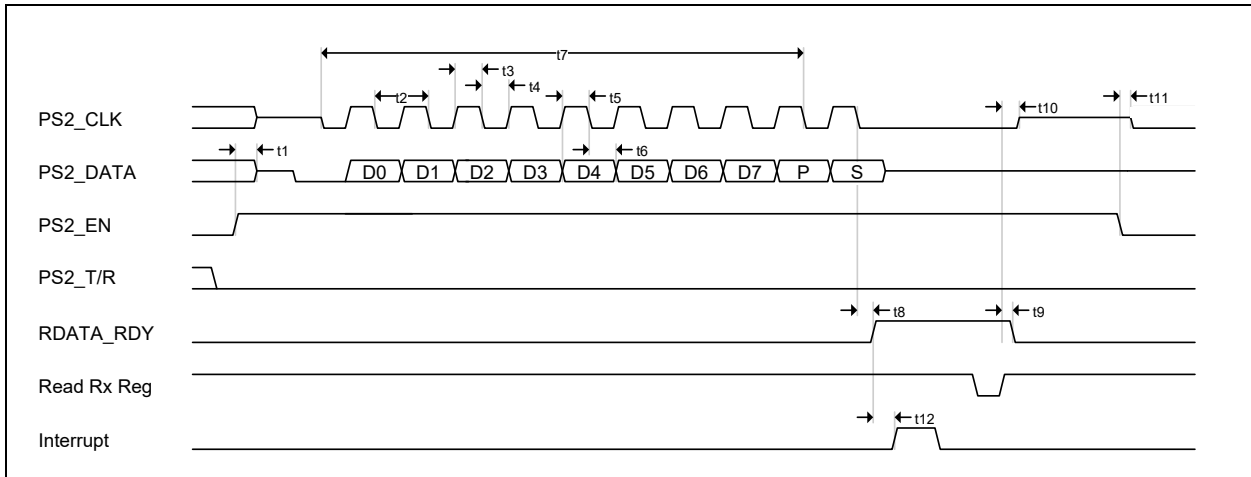

TABLE 53-11: PS/2 CHANNEL RECEIVE TIMING DIAGRAM PARAMETERS

Name	Description	MIN	TYP	MAX	Units
t1	The PS/2 Channel's CLK and DATA lines are floated following PS2_EN=1 and PS2_T/R=0.			1000	ns
t2	Period of CLK	60		302	μs
t3	Duration of CLK high (active)	30		151	
t4	Duration of CLK low (inactive)				
t5	DATA setup time to falling edge of CLK. MEC1725 samples the data line on the falling CLK edge.	1			
t6	DATA hold time from falling edge of CLK. MEC1725 samples the data line on the falling CLK edge.	2			
t7	Duration of Data Frame. Falling edge of Start bit CLK (1st clk) to falling edge of Parity bit CLK (10th clk).			2.002	ms
t8	Falling edge of 11th CLK to RDATA_RDY asserted.			1.6	μs
t9	Trailing edge of the EC's RD signal of the Receive Register to RDATA_RDY bit de-asserted.			500	ns
t10	Trailing edge of the EC's RD signal of the Receive Register to the CLK line released to high-Z.				
t11	PS2_CLK is "Low" and PS2_DATA is "Hi-Z" when PS2_EN is de-asserted.				
t12	RDATA_RDY asserted an interrupt is generated.				

MEC1725

53.14 PWM Timing

FIGURE 53-12: PWM OUTPUT TIMING

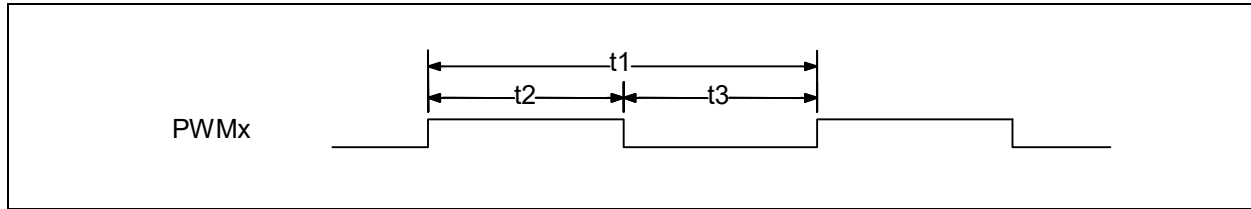

TABLE 53-12: PWM TIMING PARAMETERS

Name	Description	MIN	TYP	MAX	Units
t_1	Period	42ns		23.3sec	
f_f	Frequency	0.04Hz		24MHz	
t_2	High Time	0		11.65	sec
t_3	Low Time	0		11.65	sec
t_d	Duty cycle	0		100	%

53.15 Fan Tachometer Timing

FIGURE 53-13: FAN TACHOMETER INPUT TIMING

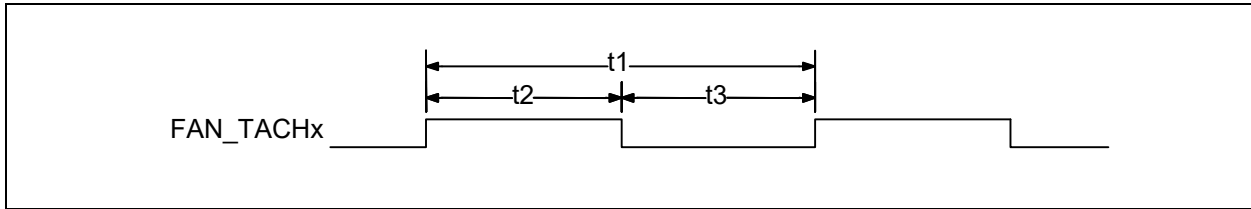

TABLE 53-13: FAN TACHOMETER INPUT TIMING PARAMETERS

Name	Description	MIN	TYP	MAX	Units
t1	Pulse Time				μsec
t2	Pulse High Time				
t3	Pulse Low Time				
Note:	t _{TACH} is the clock used for the tachometer counter. It is 30.52 * prescaler, where the prescaler is programmed in the Fan Tachometer Timebase Prescaler register.				

MEC1725

53.16 Blinking/Breathing PWM Timing

FIGURE 53-14: BLINKING/BREATHING PWM OUTPUT TIMING

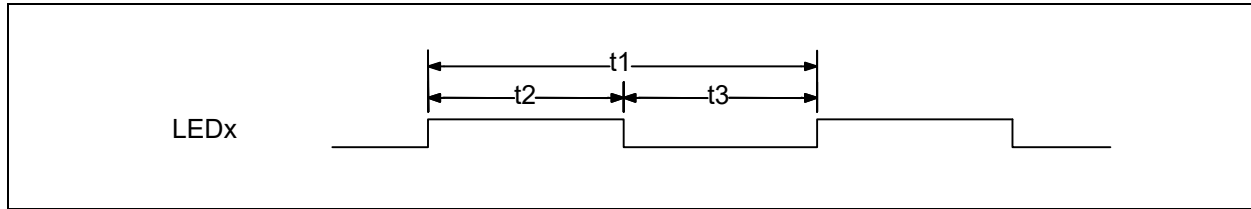

TABLE 53-14: BLINKING/BREATHING PWM TIMING PARAMETERS, BLINKING MODE

Name	Description	MIN	TYP	MAX	Units
t1	Period	7.8ms		32sec	
t _f	Frequency	0.03125		128	Hz
t2	High Time	0		16	sec
t3	Low Time	0		16	sec
t _d	Duty cycle	0		100	%

TABLE 53-15: BLINKING/BREATHING PWM TIMING PARAMETERS, GENERAL PURPOSE

Name	Description	MIN	TYP	MAX	Units
t1	Period	5.3μs		21.8ms	
t _f	Frequency	45.8Hz		187.5kHz	
t2	High Time	0		10.9	ms
t3	Low Time	0		10.9	ms
t _d	Duty cycle	0		100	%

53.17 I2C/SMBus Timing

FIGURE 53-15: I2C/SMBUS TIMING

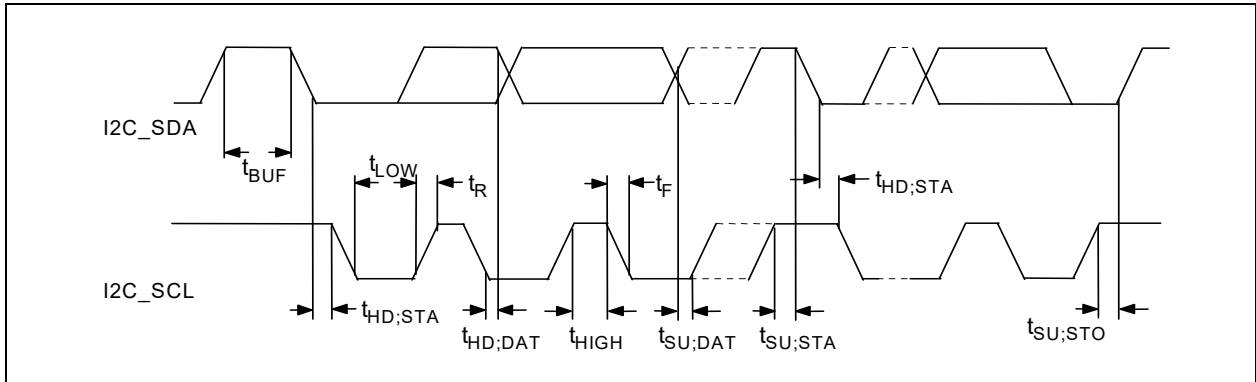
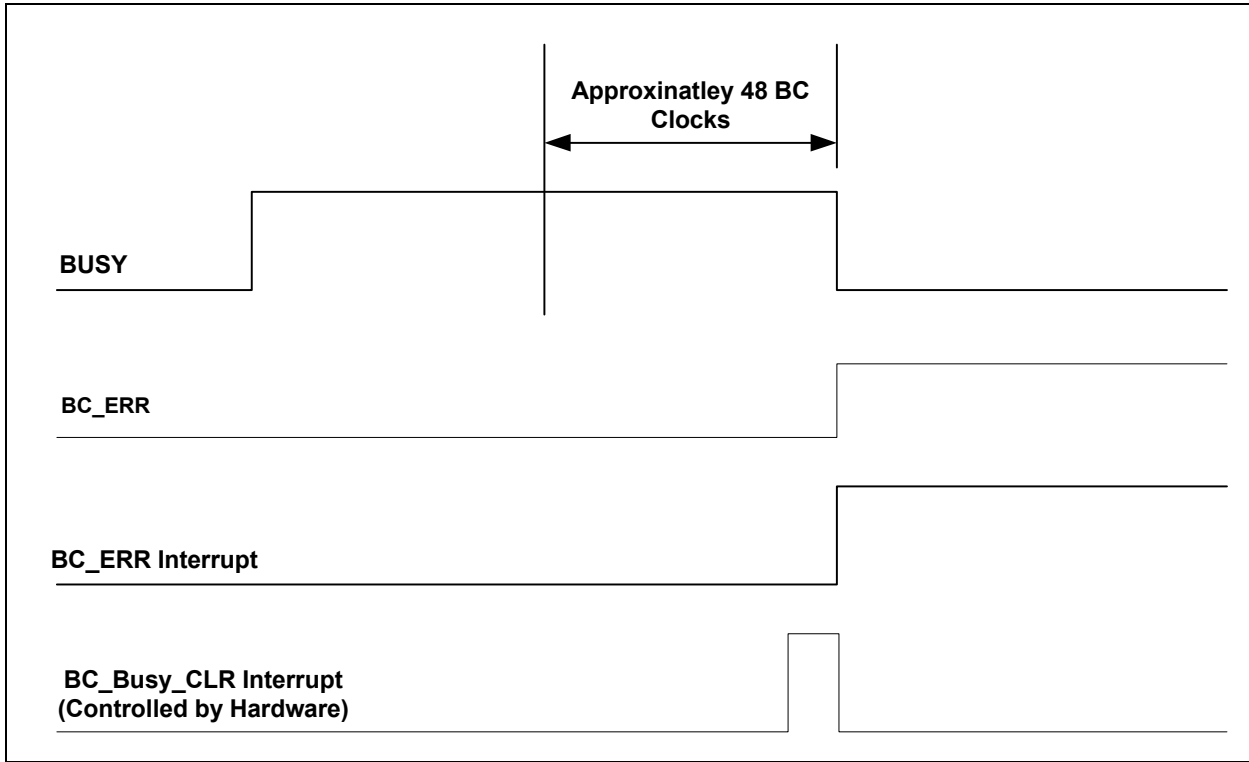

TABLE 53-16: I2C/SMBUS TIMING PARAMETERS

Symbol	Parameter	Standard-Mode		Fast-Mode		Fast-Mode Plus		Units
		MIN	MAX	MIN	MAX	MIN	MAX	
f_{SCL}	SCL Clock Frequency		100		400		1000	kHz
t_{BUF}	Bus Free Time	4.7		1.3		0.5		μs
$t_{SU;STA}$	START Condition Set-Up Time	4.7		0.6		0.26		μs
$t_{HD;STA}$	START Condition Hold Time	4.0		0.6		0.26		μs
t_{LOW}	SCL LOW Time	4.7		1.3		0.5		μs
t_{HIGH}	SCL HIGH Time	4.0		0.6		0.26		μs
t_R	SCL and SDA Rise Time		1.0		0.3		0.12	μs
t_F	SCL and SDA Fall Time		0.3		0.3		0.12	μs
$t_{SU;DAT}$	Data Set-Up Time	0.25		0.1		0.05		μs
$t_{HD;DAT}$	Data Hold Time	0		0		0		μs
$t_{SU;STO}$	STOP Condition Set-Up Time	4.0		0.6		0.26		μs

53.18 BC-Link Master Interrupt Timing

FIGURE 53-16: BC-LINK ERR INTERRUPT TIMING



53.19 BC-Link Master Timing

FIGURE 53-17: BC-LINK READ TIMING

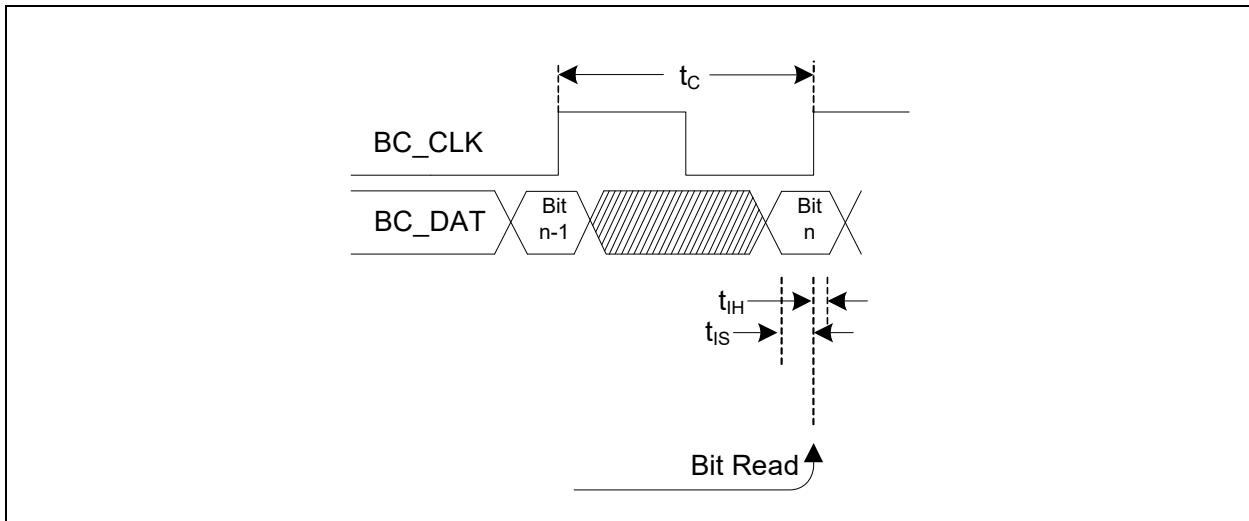

FIGURE 53-18: BC-LINK WRITE TIMING

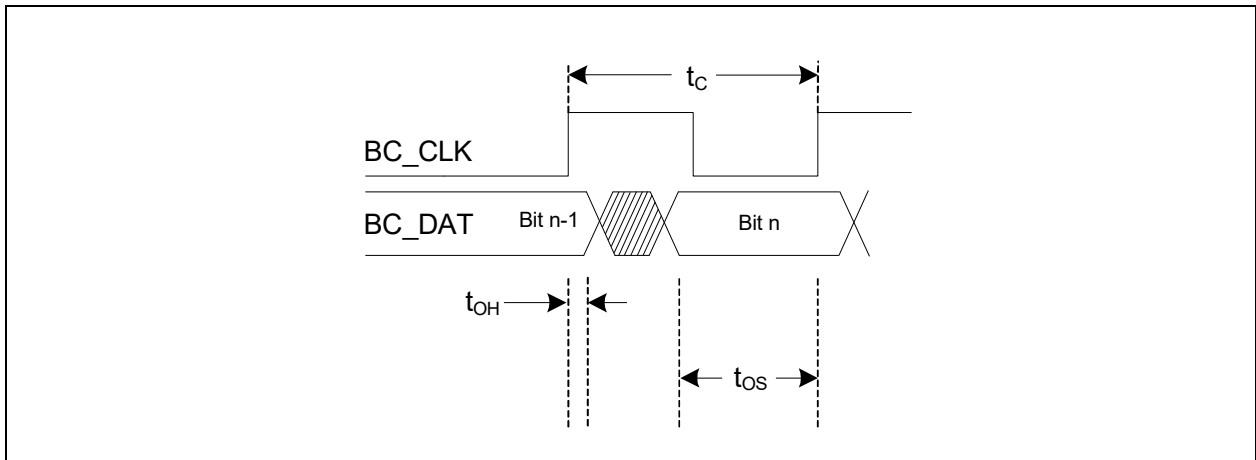

TABLE 53-17: BC-LINK MASTER TIMING DIAGRAM PARAMETERS

Name	Description	MIN	TYP	MAX	Units
t_c	BC Clock Frequency			24	MHz
t_f	BC Clock Period	42			ns
t_{OS}	BC-Link Master DATA output setup time before rising edge of CLK.			$t_c - t_{OH-MAX}$	nsec
t_{OH}	BC-Link Master Data hold time after falling edge of CLK			10	nsec
t_{IS}	BC-Link Master DATA input setup time before rising edge of CLK.	15			nsec
t_{IH}	BC-Link Master DATA input hold time after rising edge of CLK.	0			nsec

Note 1: The (t_{IH} in [Table 53-17](#)) BC-Link Master DATA input must be stable before next rising edge of CLK.

Note 2: The BC-Link Clock frequency is limited by the application usage model (see BC-Link Master [Section 40.5, "Signal Description"](#)). The BC-Link Clock frequency is controlled by the BC-Link Clock Select Register. The timing budget equation is as follows for data from BC-Link slave to master:

$$T_c > TOD(\text{master-clk}) + T_{prop}(\text{clk}) + TOD(\text{slave}) + T_{prop}(\text{slave data}) + TIS(\text{master}).$$

MEC1725

53.20 Quad SPI Master Controller - Serial Peripheral Interface (QMSPI) Timings

FIGURE 53-19: SPI CLOCK TIMING

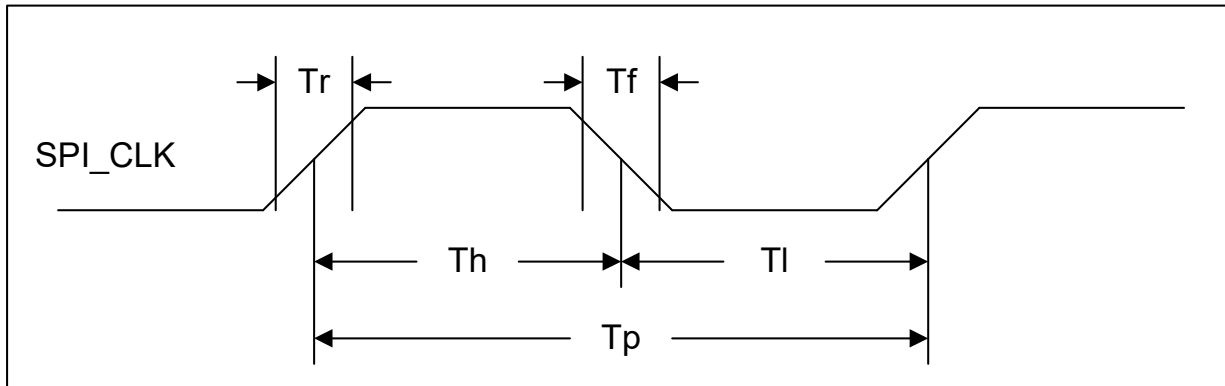
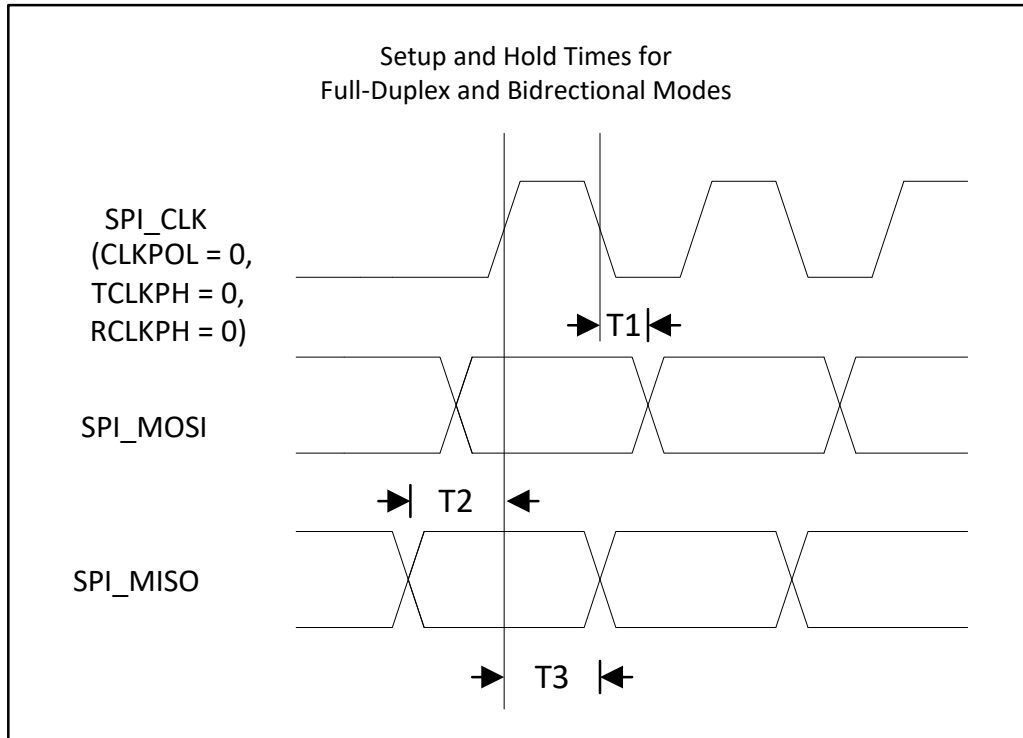

TABLE 53-18: SPI CLOCK TIMING PARAMETERS

Name	Description	MIN	TYP	MAX	Units
Tr	SPI Clock Rise Time. Measured from 10% to 90%.			3	ns
Tf	SPI Clock Fall Time. Measured from 90% to 10%.			3	ns
Th/Tl	SPI Clock High Time/SPI Clock Low Time	40% of SPCLK Period	50% of SPCLK Period	60% of SPCLK Period	ns
Tp	SPI Clock Period – As selected by SPI Clock Generator Register	20.8		5,333	ns

Note: Test conditions are as follows: output load is $C_L=30\text{pF}$, pin drive strength setting is 4mA and slew rate setting is slow.

FIGURE 53-20: SPI SETUP AND HOLD TIMES



Note: SPI_IO[3:0] obey the SPI_MOSI and SPI_MISO timing. In the 2-pin SPI Interface implementation, SPI_IO0 pin is the SPI Master-Out/Slave-In (MOSI) pin and the SPI_IO1 pin is the Master-In/Slave-out (MISO) pin.

TABLE 53-19: SPI SETUP AND HOLD TIMES PARAMETERS

Name	Description	MIN	TYP	MAX	Units
T1	Data Output Delay			2	ns
T2	Data IN Setup Time	5.5			ns
T3	Data IN Hold Time	0			ns

Note: Test conditions are as follows: output load is $C_L=30\text{pF}$, pin drive strength setting is 4mA and slew rate setting is slow

MEC1725

53.21 General Purpose Serial Peripheral Interface (GP-SPI) Timings

Note that the following timing applies to all of the MEC1725 Serial Peripheral Interface functions.

FIGURE 53-21: SPI CLOCK TIMING

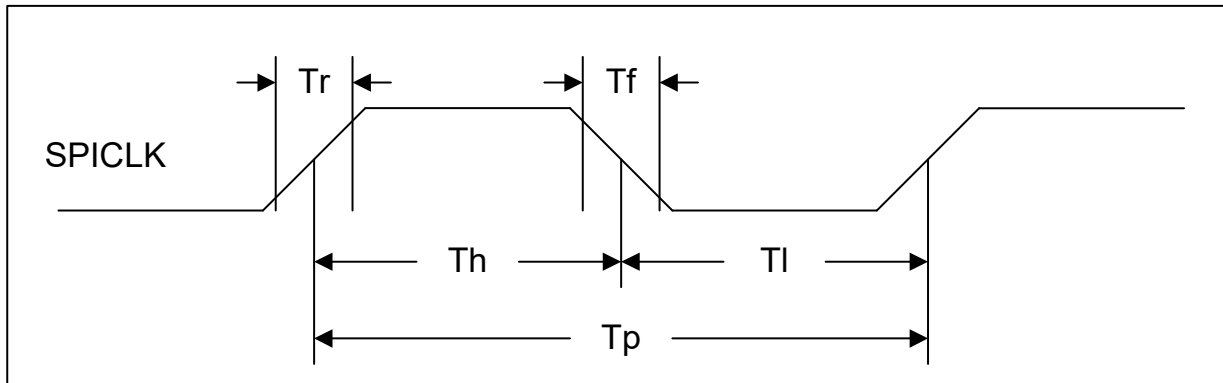
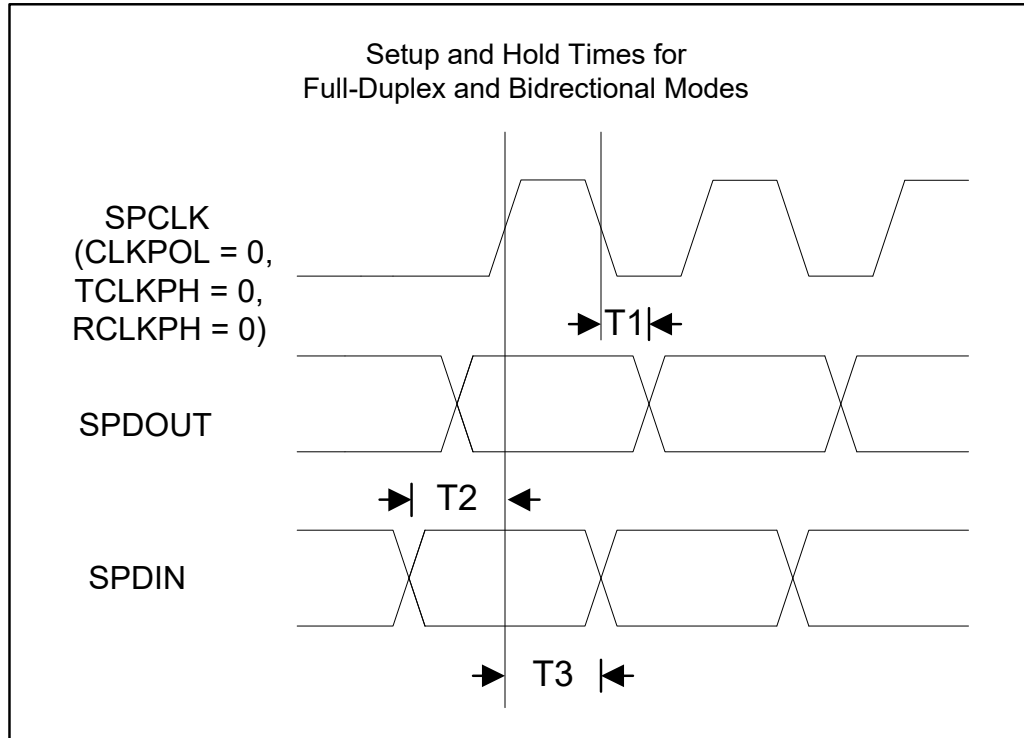

TABLE 53-20: SPI CLOCK TIMING PARAMETERS

Name	Description	MIN	TYP	MAX	Units
Tr	SPI Clock Rise Time. Measured from 10% to 90%.			3	ns
Tf	SPI Clock Fall Time. Measured from 90% to 10%.			3	ns
Th/Tl	SPI Clock High Time/SPI Clock Low Time	40% of SPCLK Period	50% of SPCLK Period	60% of SPCLK Period	ns
Tp	SPI Clock Period – As selected by SPI Clock Generator Register	20.8		62500	ns

Note: Test conditions are as follows: output load is $C_L=30\text{pF}$, pin drive strength setting is 4mA and slew rate setting is slow.

FIGURE 53-22: SPI SETUP AND HOLD TIMES



Note: SPI IO[3:0] obey the SPI_MOSI and SPI_MISO timing. In the 2-pin SPI Interface implementation, SPI_IO0 pin is the SPI Master-Out/Slave-In (MOSI) pin and the SPI_IO1 pin is the Master-In/Slave-out (MISO) pin.

TABLE 53-21: SPI SETUP AND HOLD TIMES PARAMETERS

Name	Description	MIN	TYP	MAX	Units
T1	Data Output Delay			2	ns
T2	Data IN Setup Time	5.5			ns
T3	Data IN Hold Time	0			ns

Note: Test conditions are as follows: output load is $C_L=30\text{pF}$, pin drive strength setting is 4mA and slew rate setting is slow

53.21.1 SPI INTERFACE TIMINGS

The following timing diagrams represent a single-byte transfer over the SPI interface using different SPCLK phase settings. Data bits are transmitted in bit order starting with the MSB (LSBF='0') or the LSB (LSBF='1'). See the [SPI Control Register](#) for information on the LSBF bit. The CS signal in each diagram is a generic bit-controlled chip select signal required by most peripheral devices. This signal and additional chip selects can be GPIO controlled. Note that these timings for Full Duplex Mode are also applicable to Half Duplex (or Bi-directional) mode.

MEC1725

FIGURE 53-23: INTERFACE TIMING, FULL DUPLEX MODE (TCLKPH = 0, RCLKPH = 0)

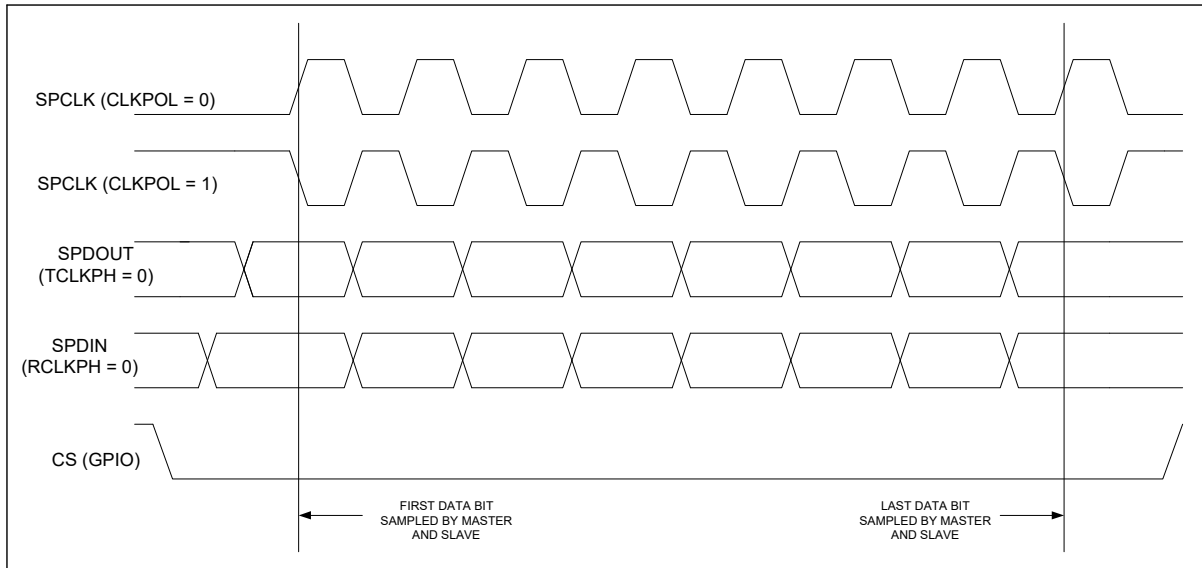

In this mode, data is available immediately when a device is selected and is sampled on the first and following odd SPCLK edges by the master and slave.

FIGURE 53-24: SPI INTERFACE TIMING, FULL DUPLEX MODE (TCLKPH = 1, RCLKPH = 0)

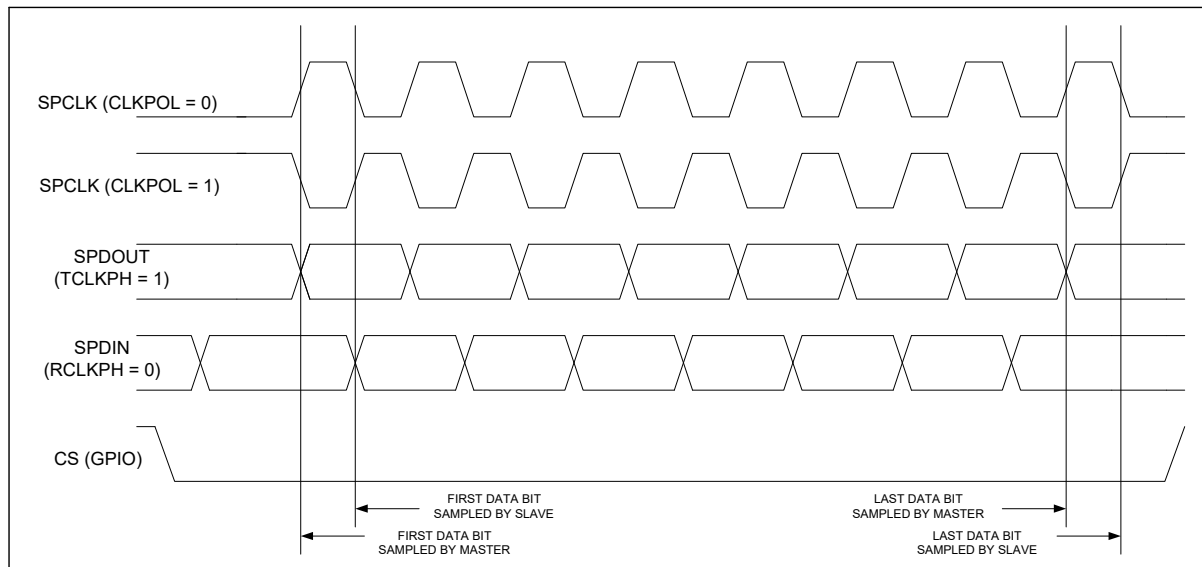

In this mode, the master requires an initial SPCLK edge before data is available. The data from slave is available immediately when the slave device is selected. The data is sampled on the first and following odd edges by the master. The data is sampled on the second and following even SPCLK edges by the slave.

FIGURE 53-25: SPI INTERFACE TIMING, FULL DUPLEX MODE (TCLKPH = 0, RCLKPH = 1)

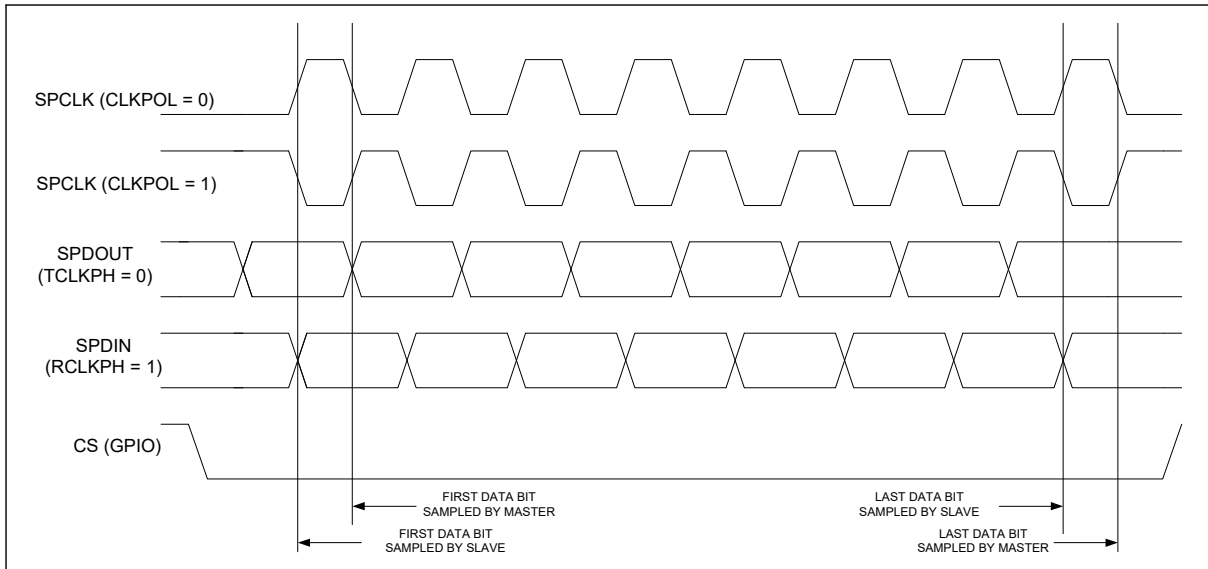

In this mode, the data from slave is available immediately when the slave device is selected. The slave device requires an initial SPCLK edge before data is available. The data is sampled on the second and following even SPCLK edges by the master. The data is sampled on the first and following odd edges by the slave.

FIGURE 53-26: SPI INTERFACE TIMING - FULL DUPLEX MODE (TCLKPH = 1, RCLKPH = 1)

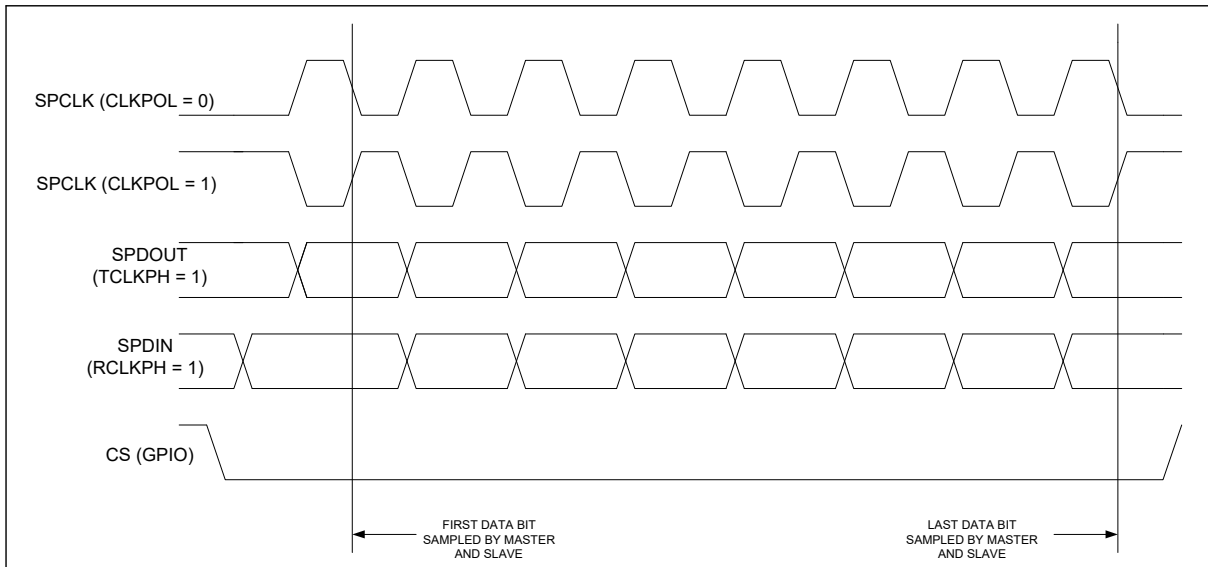

In this mode, the master and slave require an initial SPCLK edge before data is available. Data is sampled on the second and following even SPCLK edges by the master and slave.

53.22 Serial Debug Port Timing

FIGURE 53-27: SERIAL DEBUG PORT TIMING PARAMETERS

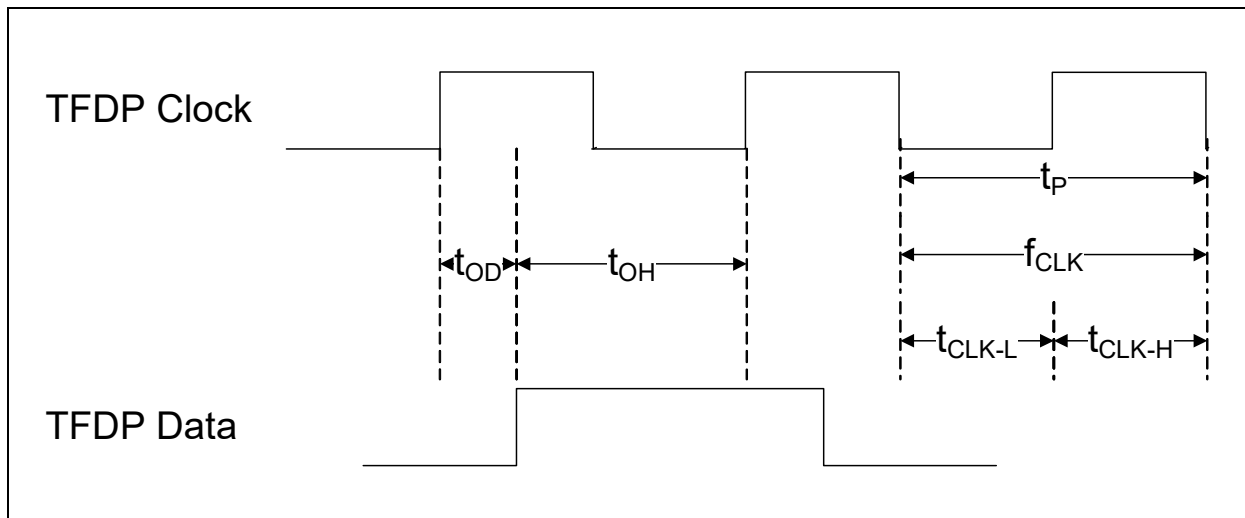

TABLE 53-22: SERIAL DEBUG PORT INTERFACE TIMING PARAMETERS

Name	Description	MIN	TYP	MAX	Units
f_{clk}	TFDP Clock frequency (see note)	2.5	-	24	MHz
t_P	TFDP Clock Period.	1/fclk			μ s
t_{OD}	TFDP Data output delay after falling edge of TFDP_Clk.			5	nsec
t_{OH}	TFDP Data hold time after falling edge of TFDP Clock	$t_P - t_{OD}$			nsec
t_{CLK-L}	TFDP Clock Low Time	$t_P/2 - 3$		$t_P/2 + 3$	nsec
t_{CLK-H}	TFDP Clock high Time (see Note 1)	$t_P/2 - 3$		$t_P/2 + 3$	nsec

Note 1: When the clock divider for the embedded controller is an odd number value greater than 2h, then $t_{CLK-L} = t_{CLK-H} + 15$ ns. When the clock divider for the embedded controller is 0h, 1h, or an even number value greater than 2h, then $t_{CLK-L} = t_{CLK-H}$.

53.23 JTAG Interface Timing

FIGURE 53-28: JTAG POWER-UP & ASYNCHRONOUS RESET TIMING

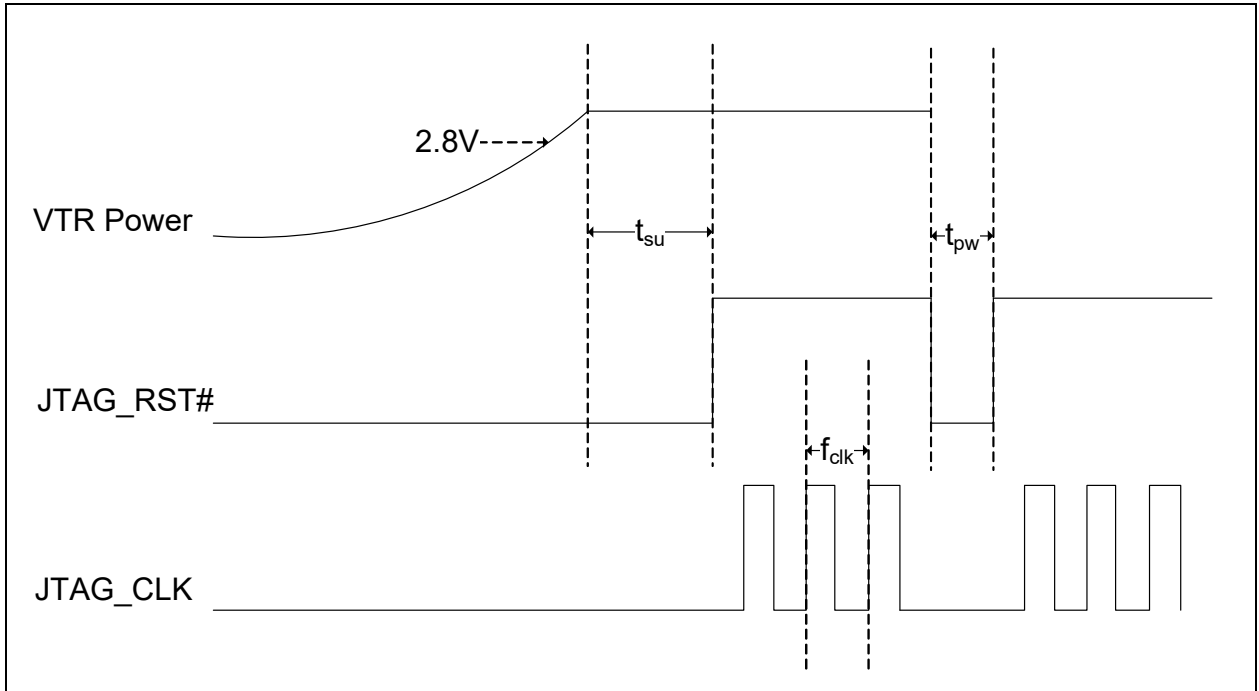
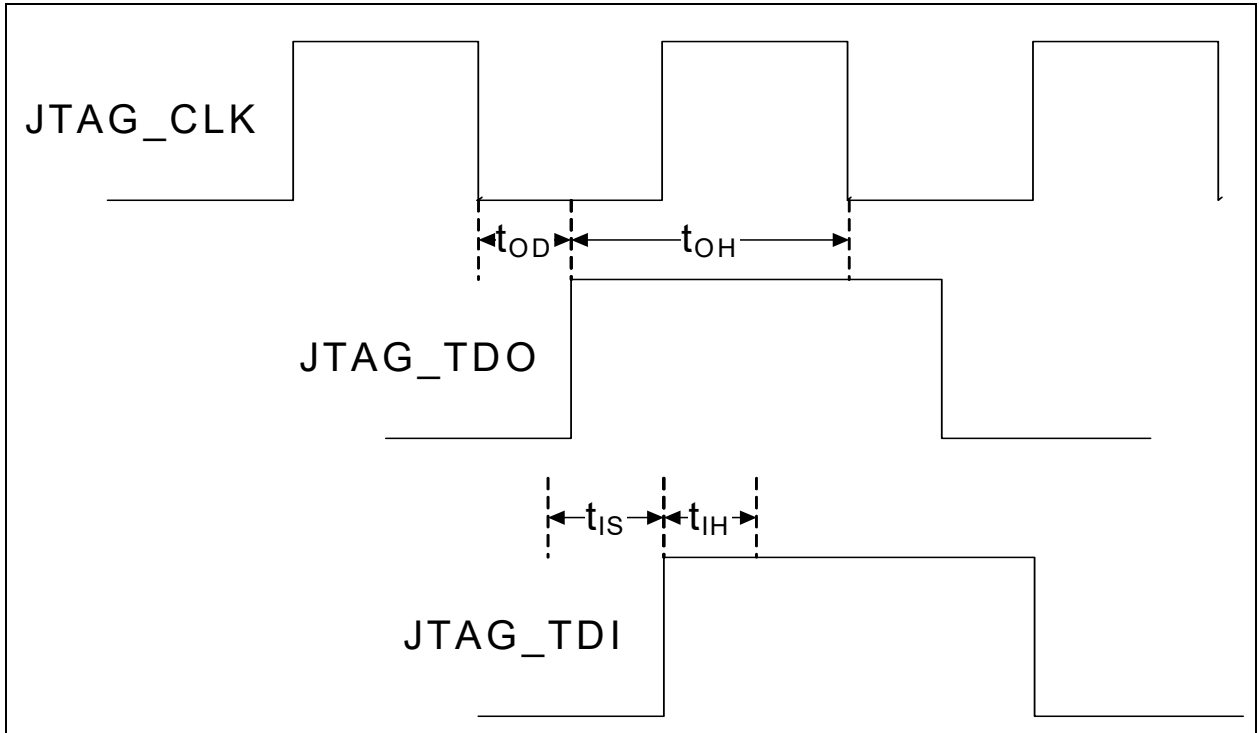

FIGURE 53-29: JTAG SETUP & HOLD PARAMETERS



MEC1725

TABLE 53-23: JTAG INTERFACE TIMING PARAMETERS

Name	Description	MIN	TYP	MAX	Units
t_{su}	JTAG_RST# de-assertion after VTR power is applied	5			ms
t_{pw}	JTAG_RST# assertion pulse width	500			nsec
f_{clk}	JTAG_CLK frequency (see note)			48	MHz
t_{OD}	TDO output delay after falling edge of TCLK.	5		10	nsec
t_{OH}	TDO hold time after falling edge of TCLK	$1 \text{ TCLK} - t_{OD}$			nsec
t_{IS}	TDI setup time before rising edge of TCLK.	5			nsec
t_{IH}	TDI hold time after rising edge of TCLK.	5			nsec

Note: f_{clk} is the maximum frequency to access a JTAG Register.

THE MICROCHIP WEB SITE

Microchip provides online support via our WWW site at www.microchip.com. This web site is used as a means to make files and information easily available to customers. Accessible by using your favorite Internet browser, the web site contains the following information:

- **Product Support** – Data sheets and errata, application notes and sample programs, design resources, user's guides and hardware support documents, latest software releases and archived software
- **General Technical Support** – Frequently Asked Questions (FAQ), technical support requests, online discussion groups, Microchip consultant program member listing
- **Business of Microchip** – Product selector and ordering guides, latest Microchip press releases, listing of seminars and events, listings of Microchip sales offices, distributors and factory representatives

CUSTOMER CHANGE NOTIFICATION SERVICE

Microchip's customer notification service helps keep customers current on Microchip products. Subscribers will receive e-mail notification whenever there are changes, updates, revisions or errata related to a specified product family or development tool of interest.

To register, access the Microchip web site at www.microchip.com. Under "Support", click on "Customer Change Notification" and follow the registration instructions.

CUSTOMER SUPPORT

Users of Microchip products can receive assistance through several channels:

- Distributor or Representative
- Local Sales Office
- Field Application Engineer (FAE)
- Technical Support

Customers should contact their distributor, representative or field application engineer (FAE) for support. Local sales offices are also available to help customers. A listing of sales offices and locations is included in the back of this document.

Technical support is available through the web site at: <http://microchip.com/support>

MEC1725

APPENDIX A: DATA SHEET REVISION HISTORY

Revision	Section/Figure/Entry	Correction
DS00003584A (10-22-20)		Document Release

PRODUCT IDENTIFICATION SYSTEM

Not all of the possible combinations of Device, Temperature Range and Package may be offered for sale. To order or obtain information, e.g., on pricing or delivery, refer to the factory or the listed sales office.

<u>PART NO.</u> ⁽¹⁾	-	<u>X</u>	-	<u>XX</u>	-	<u>X/XXX</u> ⁽²⁾	-	<u>[X]</u> ⁽³⁾
Device		Total SRAM		Version/ Revision		Temp Range/ Package		Tape and Reel Option
Device:		MEC1725 ⁽¹⁾		Embedded Controller with Authentication enabled and Thermal Monitor Integration				
Total SRAM		N		416KB				
Version/ Revision:		B#		# = Version Revision Number				
Temperature Range	I/	=		-40°C to +85°C (Industrial)				
Package:								
Tape and Reel Option:	Blank	=		Tray packaging				
	TR	=		Tape and Reel ⁽³⁾				

Example:

a) MEC1725N-B0-I/LJ = MEC1725, 416KB total SRAM, Standard ROM, ROM Version 1, 176-WFBGA 10x10mm body, Industrial grade, Tray packaging

Note 1: These products meet the halogen maximum concentration values per IEC61249-2-21.

2: All package options are RoHS compliant. For RoHS compliance and environmental information, please visit <http://www.microchip.com/pagehandler/en-us/aboutus/ehs.html>

3: Tape and Reel identifier only appears in the catalog part number description. This identifier is used for ordering purposes and is not printed on the device package. Check with your Microchip Sales Office for package availability with the Tape and Reel option

Note the following details of the code protection feature on Microchip devices:

- Microchip products meet the specifications contained in their particular Microchip Data Sheet.
- Microchip believes that its family of products is secure when used in the intended manner and under normal conditions.
- There are dishonest and possibly illegal methods being used in attempts to breach the code protection features of the Microchip devices. We believe that these methods require using the Microchip products in a manner outside the operating specifications contained in Microchip's Data Sheets. Attempts to breach these code protection features, most likely, cannot be accomplished without violating Microchip's intellectual property rights.
- Microchip is willing to work with any customer who is concerned about the integrity of its code.
- Neither Microchip nor any other semiconductor manufacturer can guarantee the security of its code. Code protection does not mean that we are guaranteeing the product is "unbreakable." Code protection is constantly evolving. We at Microchip are committed to continuously improving the code protection features of our products. Attempts to break Microchip's code protection feature may be a violation of the Digital Millennium Copyright Act. If such acts allow unauthorized access to your software or other copyrighted work, you may have a right to sue for relief under that Act.

Information contained in this publication is provided for the sole purpose of designing with and using Microchip products. Information regarding device applications and the like is provided only for your convenience and may be superseded by updates. It is your responsibility to ensure that your application meets with your specifications.

THIS INFORMATION IS PROVIDED BY MICROCHIP "AS IS". MICROCHIP MAKES NO REPRESENTATIONS OR WARRANTIES OF ANY KIND WHETHER EXPRESS OR IMPLIED, WRITTEN OR ORAL, STATUTORY OR OTHERWISE, RELATED TO THE INFORMATION INCLUDING BUT NOT LIMITED TO ANY IMPLIED WARRANTIES OF NON-INFRINGEMENT, MERCHANTABILITY, AND FITNESS FOR A PARTICULAR PURPOSE OR WARRANTIES RELATED TO ITS CONDITION, QUALITY, OR PERFORMANCE.

IN NO EVENT WILL MICROCHIP BE LIABLE FOR ANY INDIRECT, SPECIAL, PUNITIVE, INCIDENTAL OR CONSEQUENTIAL LOSS, DAMAGE, COST OR EXPENSE OF ANY KIND WHATSOEVER RELATED TO THE INFORMATION OR ITS USE, HOWEVER CAUSED, EVEN IF MICROCHIP HAS BEEN ADVISED OF THE POSSIBILITY OR THE DAMAGES ARE FORESEEABLE. TO THE FULLEST EXTENT ALLOWED BY LAW, MICROCHIP'S TOTAL LIABILITY ON ALL CLAIMS IN ANY WAY RELATED TO THE INFORMATION OR ITS USE WILL NOT EXCEED THE AMOUNT OF FEES, IF ANY, THAT YOU HAVE PAID DIRECTLY TO MICROCHIP FOR THE INFORMATION. Use of Microchip devices in life support and/or safety applications is entirely at the buyer's risk, and the buyer agrees to defend, indemnify and hold harmless Microchip from any and all damages, claims, suits, or expenses resulting from such use. No licenses are conveyed, implicitly or otherwise, under any Microchip intellectual property rights unless otherwise stated.

Trademarks

The Microchip name and logo, the Microchip logo, Adaptec, AnyRate, AVR, AVR logo, AVR Freaks, BesTime, BitCloud, chipKIT, chipKIT logo, CryptoMemory, CryptoRF, dsPIC, FlashFlex, flexPWR, HELDO, IGLoo, JukeBlox, KeelQ, Kleer, LANCheck, LinkMD, maXStylus, maXTouch, MediaLB, megaAVR, Microsemi, Microsemi logo, MOST, MOST logo, MPLAB, OptoLyzer, PackeTime, PIC, picoPower, PICSTART, PIC32 logo, PolarFire, Prochip Designer, QTouch, SAM-BA, SenGenuity, SpyNIC, SST, SST Logo, SuperFlash, Symmetricom, SyncServer, Tachyon, TempTrackr, TimeSource, tinyAVR, UNI/O, Vectron, and XMEGA are registered trademarks of Microchip Technology Incorporated in the U.S.A. and other countries.

APT, ClockWorks, The Embedded Control Solutions Company, EtherSynch, FlashTec, Hyper Speed Control, HyperLight Load, IntellIMOS, Libero, motorBench, mTouch, Powermite 3, Precision Edge, ProASIC, ProASIC Plus, ProASIC Plus logo, Quiet-Wire, SmartFusion, SyncWorld, Temux, TimeCesium, TimeHub, TimePictra, TimeProvider, Vite, WinPath, and ZL are registered trademarks of Microchip Technology Incorporated in the U.S.A.

Adjacent Key Suppression, AKS, Analog-for-the-Digital Age, Any Capacitor, AnyIn, AnyOut, BlueSky, BodyCom, CodeGuard, CryptoAuthentication, CryptoAutomotive, CryptoCompanion, CryptoController, dsPICDEM, dsPICDEM.net, Dynamic Average Matching, DAM, ECAN, EtherGREEN, In-Circuit Serial Programming, ICSP, INICnet, Inter-Chip Connectivity, JitterBlocker, KleerNet, KleerNet logo, memBrain, Mindi, MiWi, MPASM, MPF, MPLAB Certified logo, MPLIB, MPLINK, MultiTRAK, NetDetach, Omniscient Code Generation, PICDEM, PICDEM.net, PICKit, PICtail, PowerSmart, PureSilicon, QMatrix, REAL ICE, Ripple Blocker, SAM-ICE, Serial Quad I/O, SMART-I.S., SQI, SuperSwitcher, SuperSwitcher II, Total Endurance, TSHARC, USBCheck, VariSense, ViewSpan, WiperLock, Wireless DNA, and ZENA are trademarks of Microchip Technology Incorporated in the U.S.A. and other countries.

SQTP is a service mark of Microchip Technology Incorporated in the U.S.A.

The Adaptec logo, Frequency on Demand, Silicon Storage Technology, and Symmcom are registered trademarks of Microchip Technology Inc. in other countries.

GestIC is a registered trademark of Microchip Technology Germany II GmbH & Co. KG, a subsidiary of Microchip Technology Inc., in other countries.

AMBA, Arm, Arm7, Arm7TDMI, Arm9, Arm11, Artisan, big.LITTLE, Cordio, CoreLink, CoreSight, Cortex, DesignStart, DynamiQ, Jazelle, Keil, Mali, Mbed, Mbed Enabled, NEON, POP, RealView, SecurCore, Socrates, Thumb, TrustZone, ULINK, ULINK2, ULINK-ME, ULINK-PLUS, ULINKpro, µVision, Versatile are trademarks or registered trademarks of Arm Limited (or its subsidiaries) in the US and/or elsewhere.

All other trademarks mentioned herein are property of their respective companies.

© 2020, Microchip Technology Incorporated, All Rights Reserved.

ISBN: 9781522464686

For information regarding Microchip's Quality Management Systems, please visit www.microchip.com/quality.



Worldwide Sales and Service

AMERICAS

Corporate Office
2355 West Chandler Blvd.
Chandler, AZ 85224-6199
Tel: 480-792-7200
Fax: 480-792-7277
Technical Support:
<http://www.microchip.com/support>
Web Address:
www.microchip.com

Atlanta

Duluth, GA
Tel: 678-957-9614
Fax: 678-957-1455

Austin, TX

Tel: 512-257-3370

Boston

Westborough, MA
Tel: 774-760-0087
Fax: 774-760-0088

Chicago

Itasca, IL
Tel: 630-285-0071
Fax: 630-285-0075

Dallas

Addison, TX
Tel: 972-818-7423
Fax: 972-818-2924

Detroit

Novi, MI
Tel: 248-848-4000

Houston, TX

Tel: 281-894-5983

Indianapolis

Noblesville, IN
Tel: 317-773-8323
Fax: 317-773-5453
Tel: 317-536-2380

Los Angeles

Mission Viejo, CA
Tel: 949-462-9523
Fax: 949-462-9608
Tel: 951-273-7800

Raleigh, NC

Tel: 919-844-7510

New York, NY

Tel: 631-435-6000

San Jose, CA

Tel: 408-735-9110
Tel: 408-436-4270

Canada - Toronto

Tel: 905-695-1980
Fax: 905-695-2078

ASIA/PACIFIC

Australia - Sydney
Tel: 61-2-9868-6733

China - Beijing
Tel: 86-10-8569-7000

China - Chengdu
Tel: 86-28-8665-5511

China - Chongqing
Tel: 86-23-8980-9588

China - Dongguan
Tel: 86-769-8702-9880

China - Guangzhou
Tel: 86-20-8755-8029

China - Hangzhou
Tel: 86-571-8792-8115

China - Hong Kong SAR
Tel: 852-2943-5100

China - Nanjing
Tel: 86-25-8473-2460

China - Qingdao
Tel: 86-532-8502-7355

China - Shanghai
Tel: 86-21-3326-8000

China - Shenyang
Tel: 86-24-2334-2829

China - Shenzhen
Tel: 86-755-8864-2200

China - Suzhou
Tel: 86-186-6233-1526

China - Wuhan
Tel: 86-27-5980-5300

China - Xian
Tel: 86-29-8833-7252

China - Xiamen
Tel: 86-592-2388138

China - Zhuhai
Tel: 86-756-3210040

ASIA/PACIFIC

India - Bangalore
Tel: 91-80-3090-4444

India - New Delhi
Tel: 91-11-4160-8631

India - Pune
Tel: 91-20-4121-0141

Japan - Osaka
Tel: 81-6-6152-7160

Japan - Tokyo
Tel: 81-3-6880-3770

Korea - Daegu
Tel: 82-53-744-4301

Korea - Seoul
Tel: 82-2-554-7200

Malaysia - Kuala Lumpur
Tel: 60-3-7651-7906

Malaysia - Penang
Tel: 60-4-227-8870

Philippines - Manila
Tel: 63-2-634-9065

Singapore
Tel: 65-6334-8870

Taiwan - Hsin Chu
Tel: 886-3-577-8366

Taiwan - Kaohsiung
Tel: 886-7-213-7830

Taiwan - Taipei
Tel: 886-2-2508-8600

Thailand - Bangkok
Tel: 66-2-694-1351

Vietnam - Ho Chi Minh
Tel: 84-28-5448-2100

EUROPE

Austria - Wels
Tel: 43-7242-2244-39
Fax: 43-7242-2244-393

Denmark - Copenhagen
Tel: 45-4485-5910
Fax: 45-4485-2829

Finland - Espoo
Tel: 358-9-4520-820

France - Paris
Tel: 33-1-69-53-63-20
Fax: 33-1-69-30-90-79

Germany - Garching
Tel: 49-8931-9700

Germany - Haan
Tel: 49-2129-3766400

Germany - Heilbronn
Tel: 49-7131-72400

Germany - Karlsruhe
Tel: 49-721-625370

Germany - Munich
Tel: 49-89-627-144-0
Fax: 49-89-627-144-44

Germany - Rosenheim
Tel: 49-8031-354-560

Israel - Ra'anana
Tel: 972-9-744-7705

Italy - Milan
Tel: 39-0331-742611
Fax: 39-0331-466781

Italy - Padova
Tel: 39-049-7625286

Netherlands - Drunen
Tel: 31-416-690399
Fax: 31-416-690340

Norway - Trondheim
Tel: 47-7288-4388

Poland - Warsaw
Tel: 48-22-3325737

Romania - Bucharest
Tel: 40-21-407-87-50

Spain - Madrid
Tel: 34-91-708-08-90
Fax: 34-91-708-08-91

Sweden - Gothenberg
Tel: 46-31-704-60-40

Sweden - Stockholm
Tel: 46-8-5090-4654

UK - Wokingham
Tel: 44-118-921-5800
Fax: 44-118-921-5820