

REVISION HISTORY		
09/03/2010	1	INITIAL RELEASE
09/20/2010	1.1	PROTOTYPE REWORK - TP GPIO MOVE
10/21/2010	1.2	PROTOTYPE REWORK - LCD POWER SWITCH
11/16/2010	2.0	ADD EXTERNAL SPEAKER CONNECTOR ADD OFF-BOARD BATTERY CONNECTOR SHOW DNL OPTIONS FOR LPC1788 VS LPC1788
7/18/2011	2.1	CHANGE J10 & R51 TO BE LOADED
12/1/2011	2.2	CHANGE BACKLIGHT CURRENT FOR SEIKO LCD

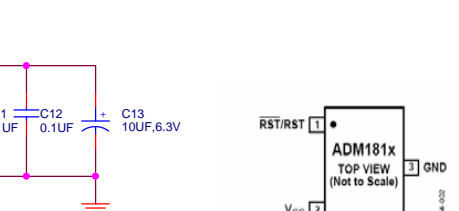
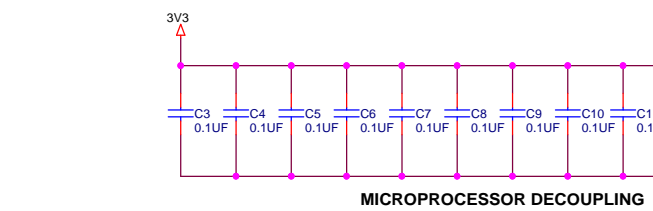
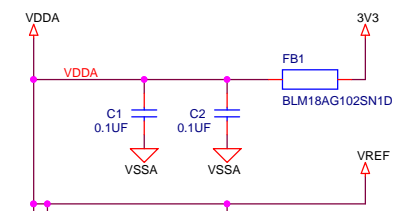
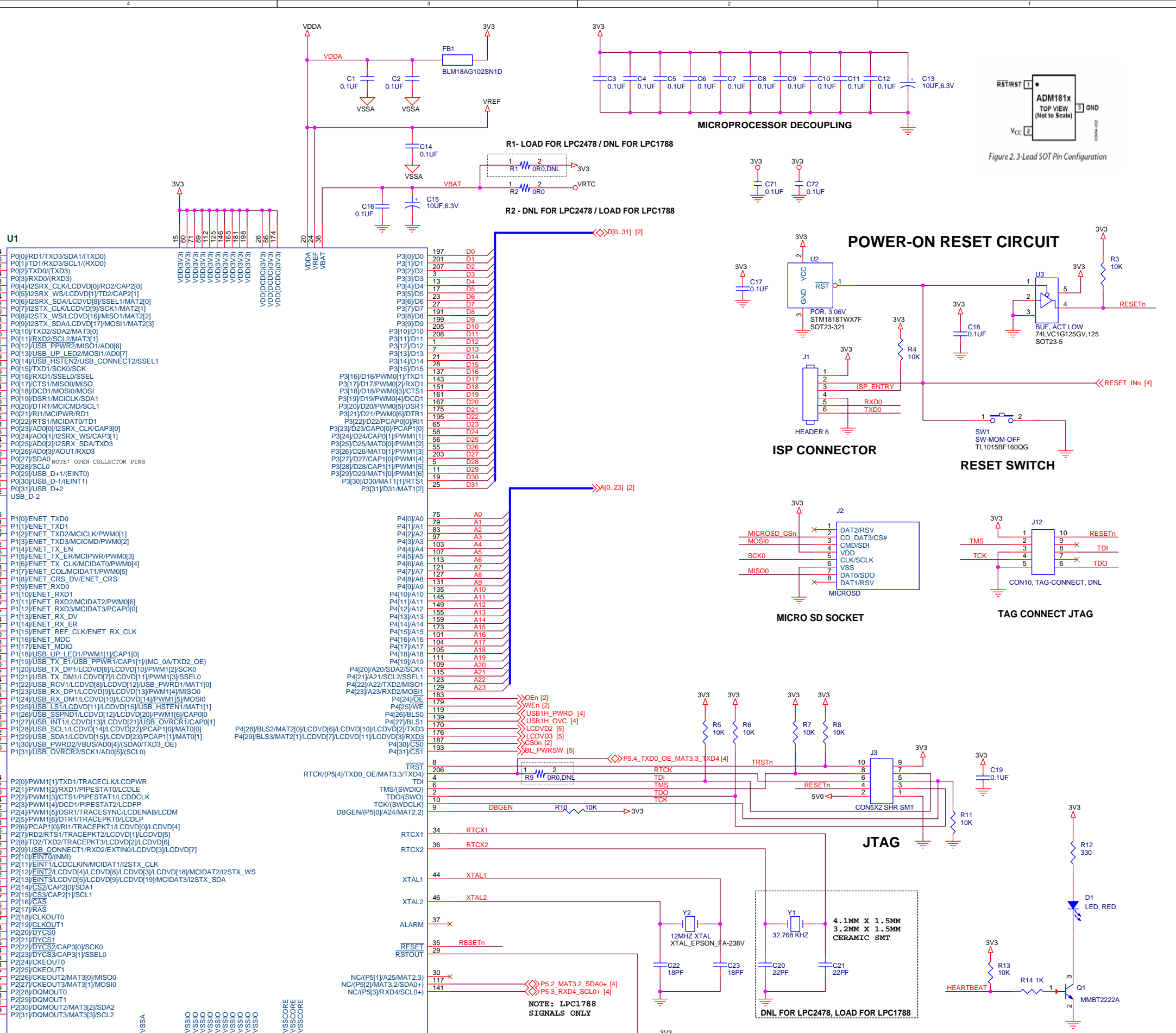
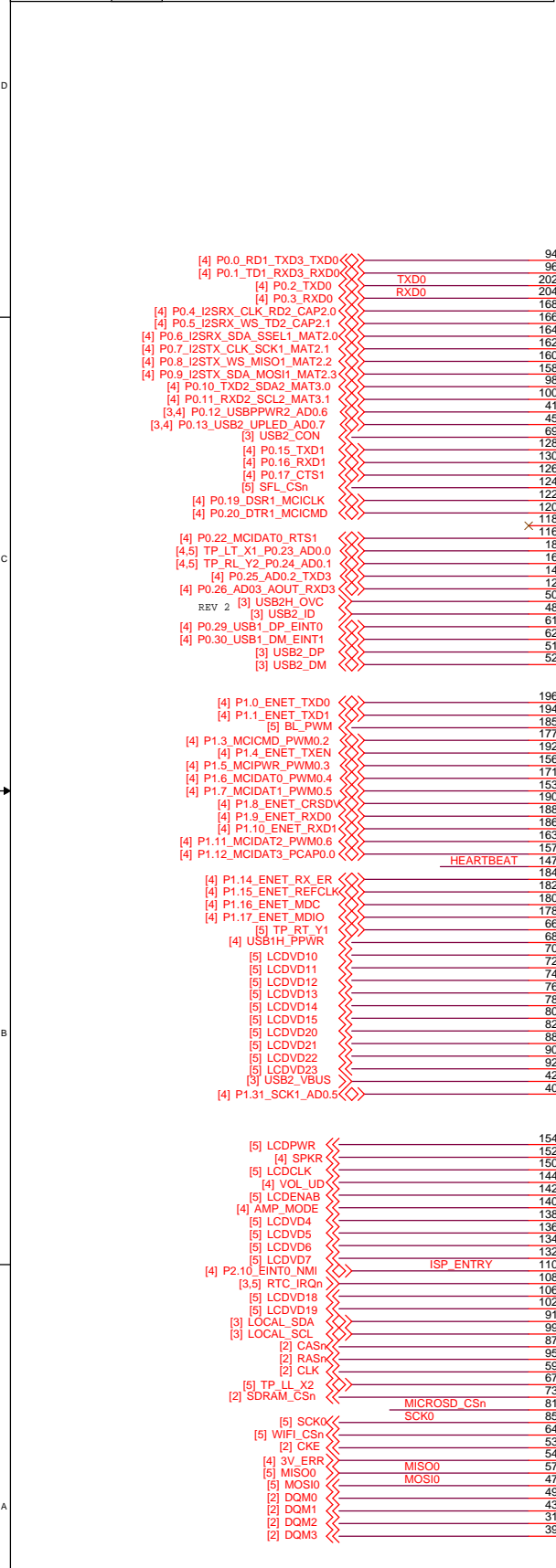
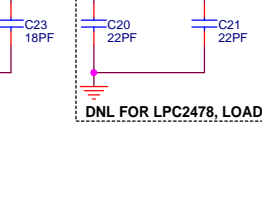
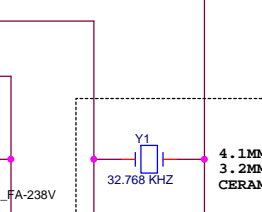
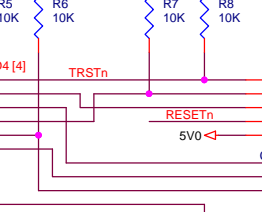
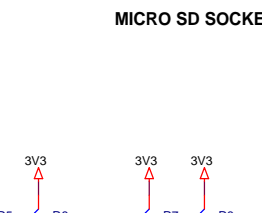
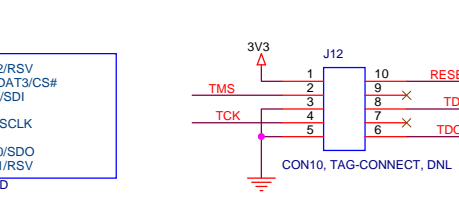
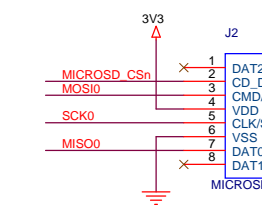
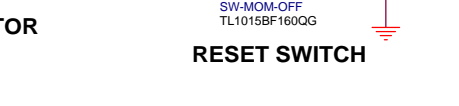
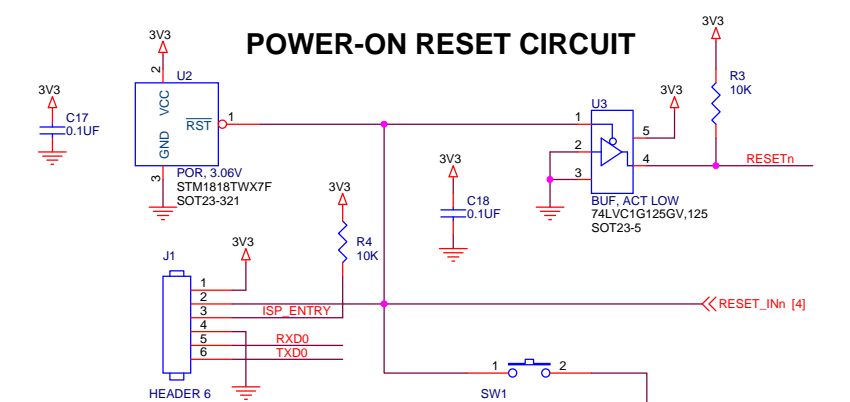
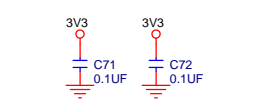

Figure 2. 3-Lead SOT Pin Configuration



MCU, 512K, 96KB
LPC1788FBD208
LQFP208_SOT469-1
OPTIONAL: LPLC2478FBD208

FUTURE DESIGNS, INC. 2702 TRIANA BLVD HUNTSVILLE, AL 35805		
Title	MICROPROCESSOR	
Size	Document Number	Rev
C	UEZGUI 7.0"	3
Date:	Monday, January 30, 2012	Sheet 1 of 5



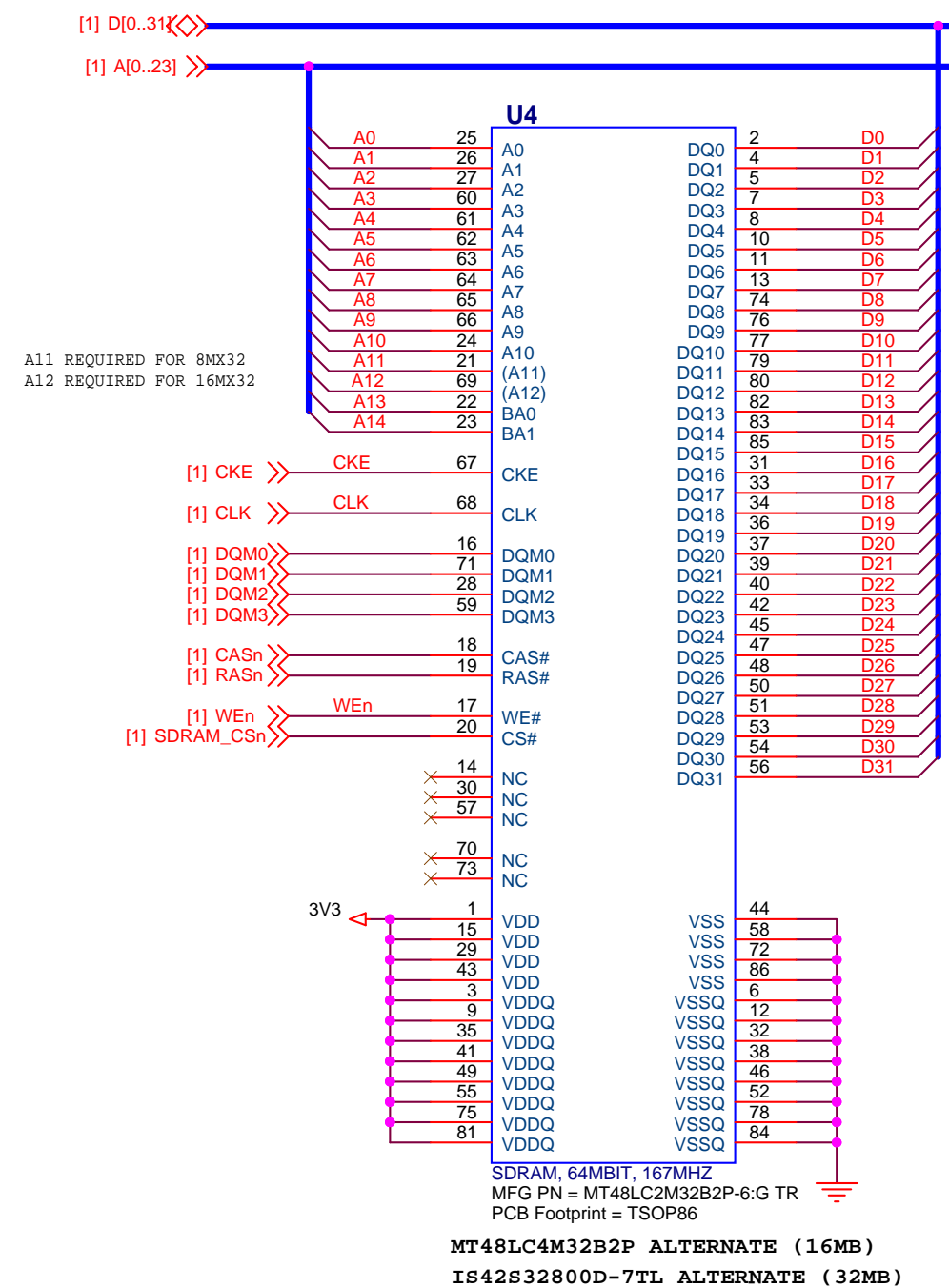

SDRAM (8MB TO 32MB)

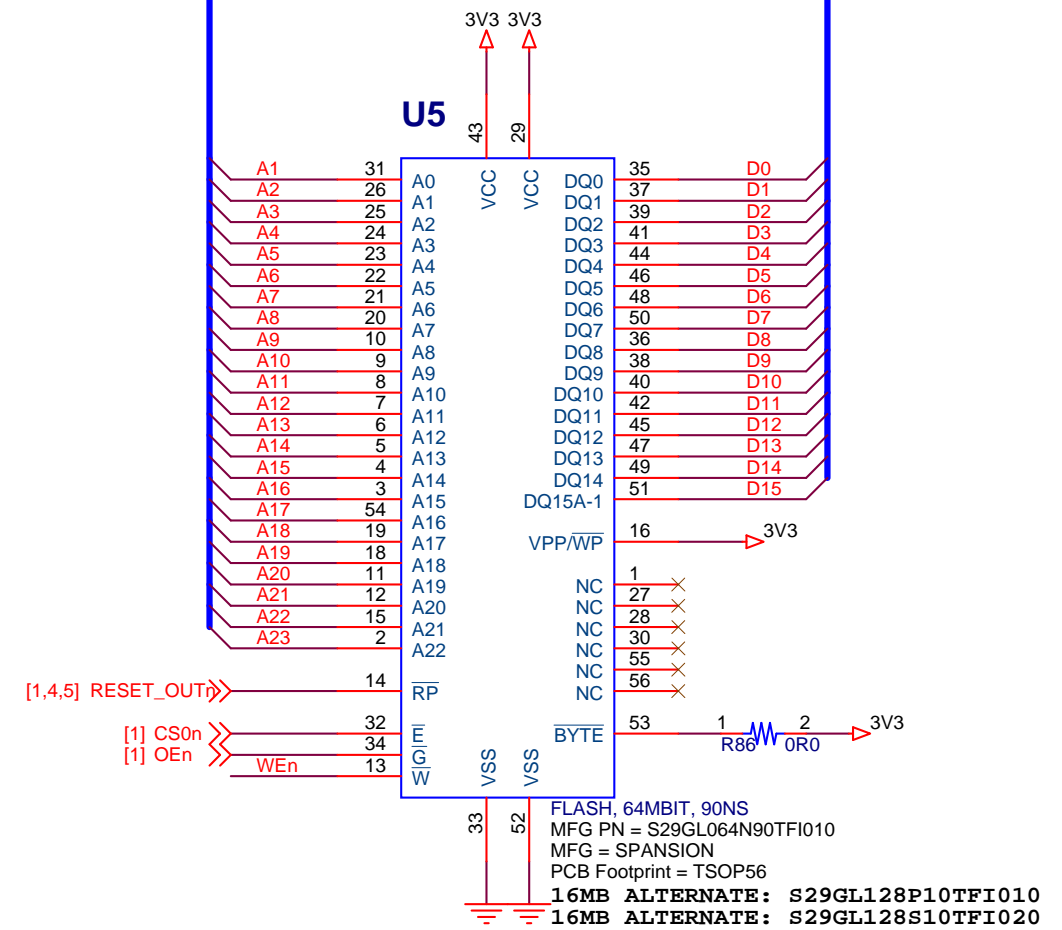
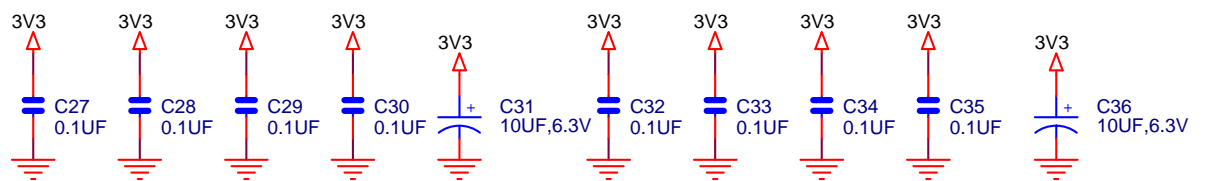

NOR FLASH (8MB TO 16MB)

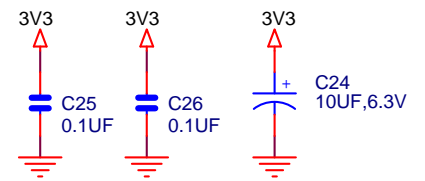

FUTURE DESIGNS, INC. 2702 TRIANA BLVD HUNTSVILLE, AL 35805		FDI
Title SDRAM FLASH		
Size B	Document Number UEZGUI 7.0"	Rev 3
Date: Monday, January 30, 2012	Sheet 2	of 5

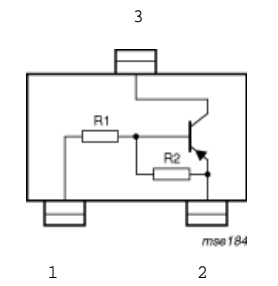
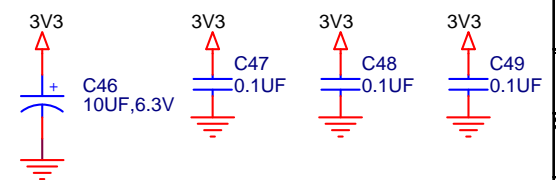
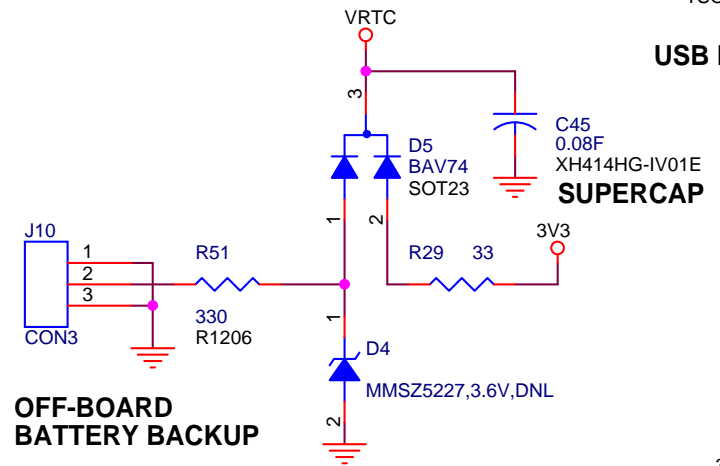
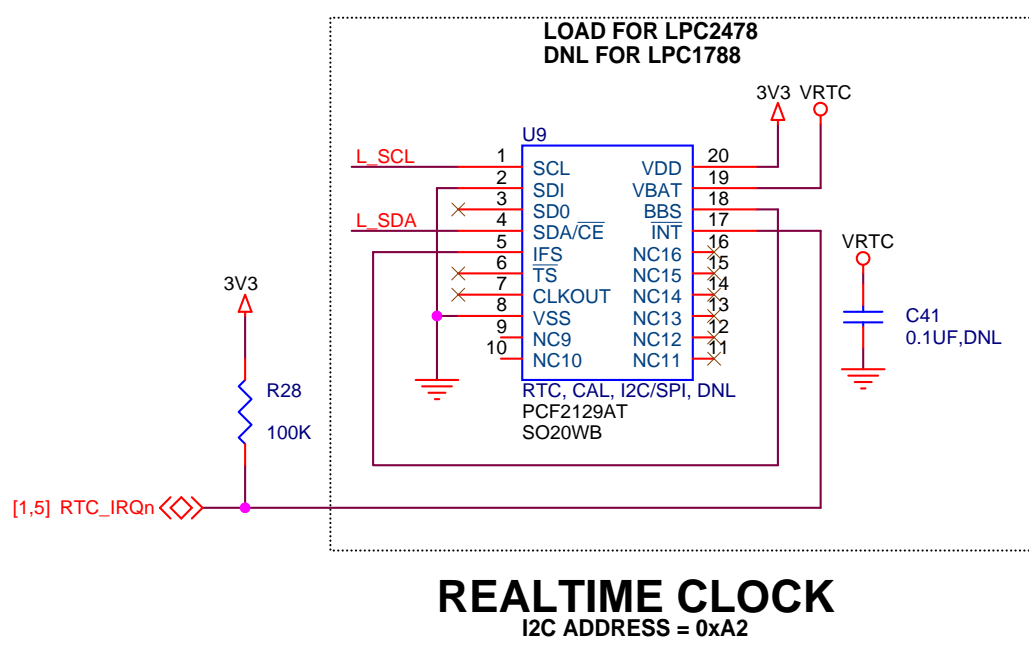
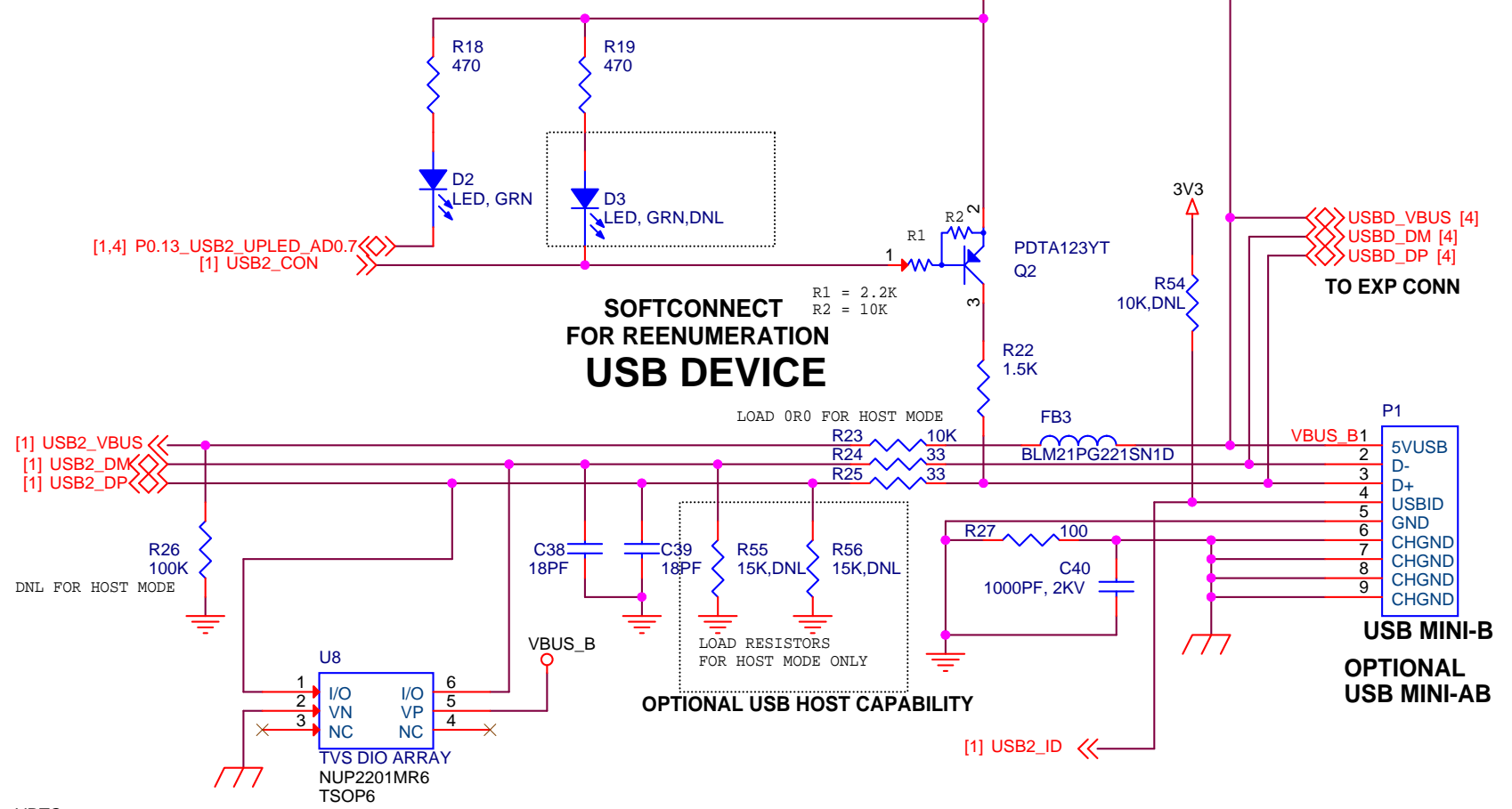
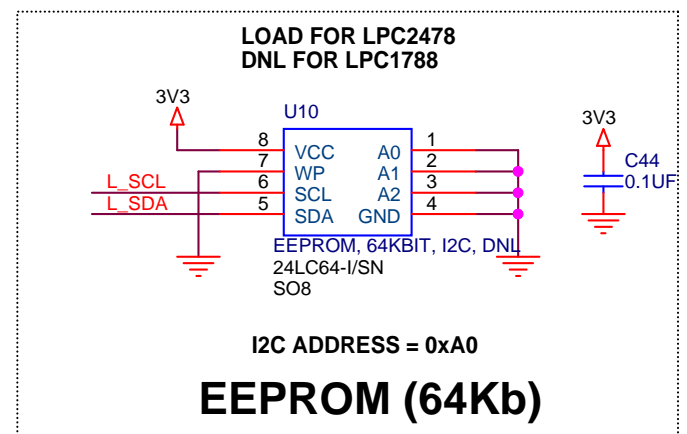
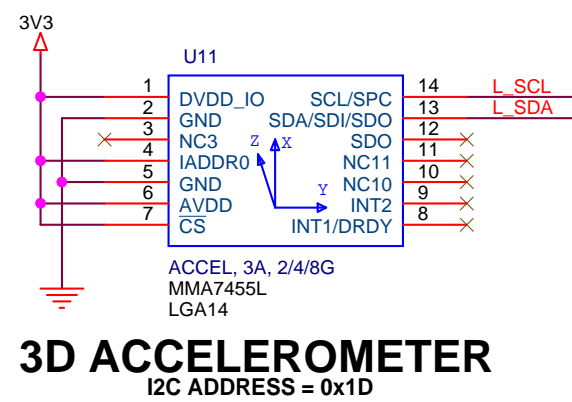
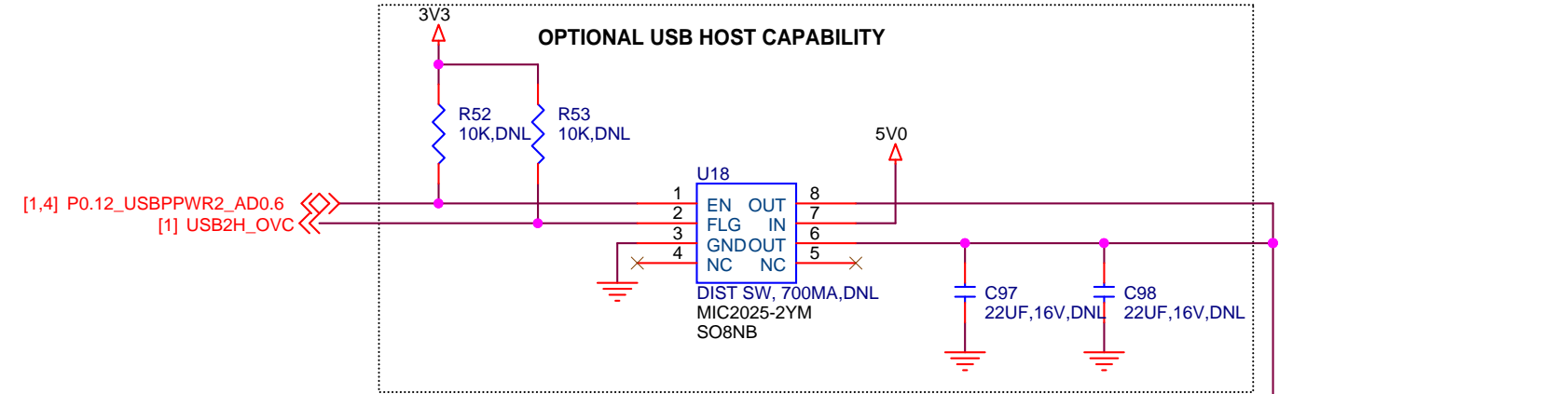
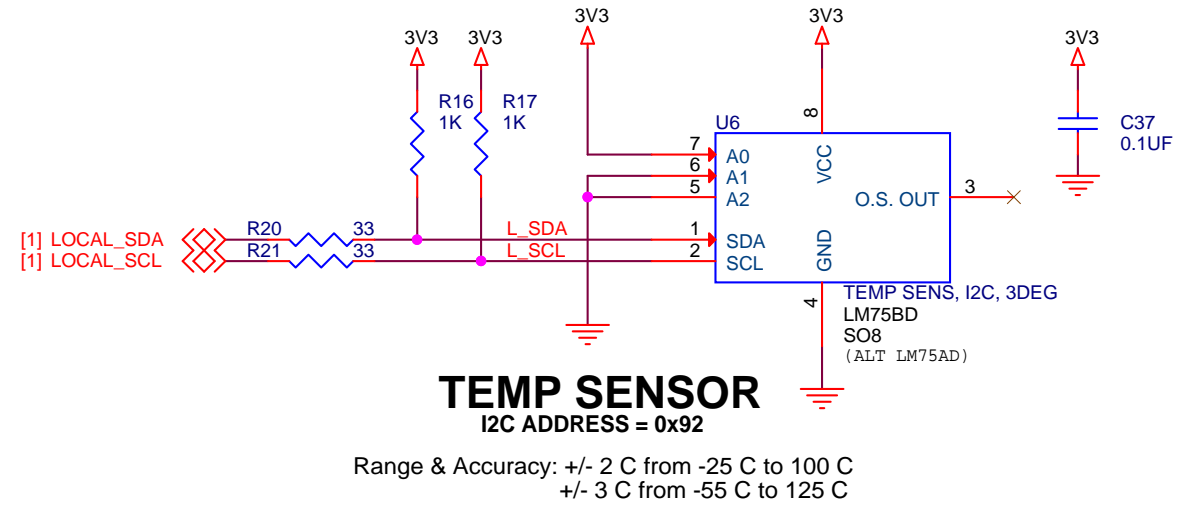

FUTURE DESIGNS, INC. 2702 TRIANA BLVD HUNTSVILLE, AL 35805		FDI
Title: USB DEVICE I2C PERIPHERALS		
Size: B	Document Number: UEZGUI 7.0*	Rev: 3
Date: Monday, January 30, 2012	Sheet: 3	of 5

3.3V REGULATOR, 0.8A

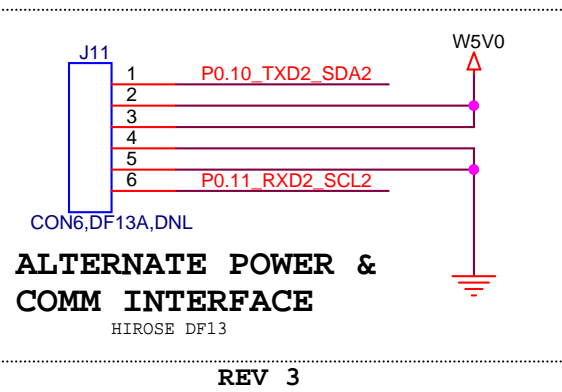
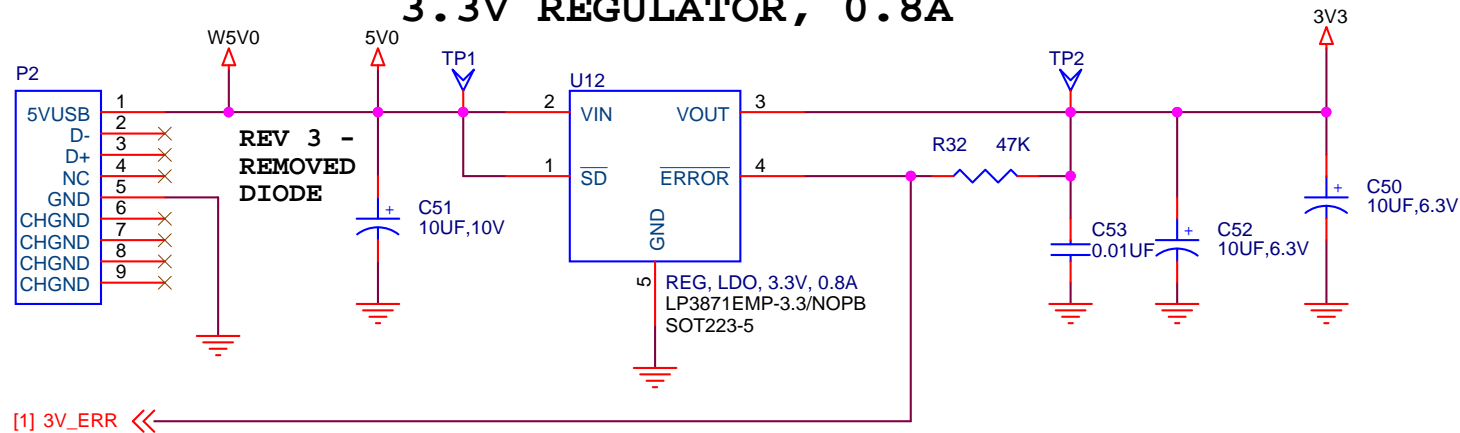

WALL 5V INPUT MONITOR VIA ADC

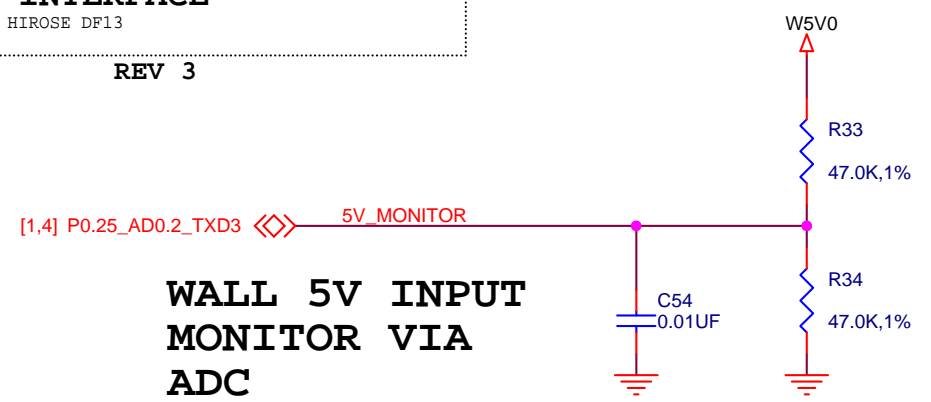

SECONDARY EXPANSION CONNECTOR

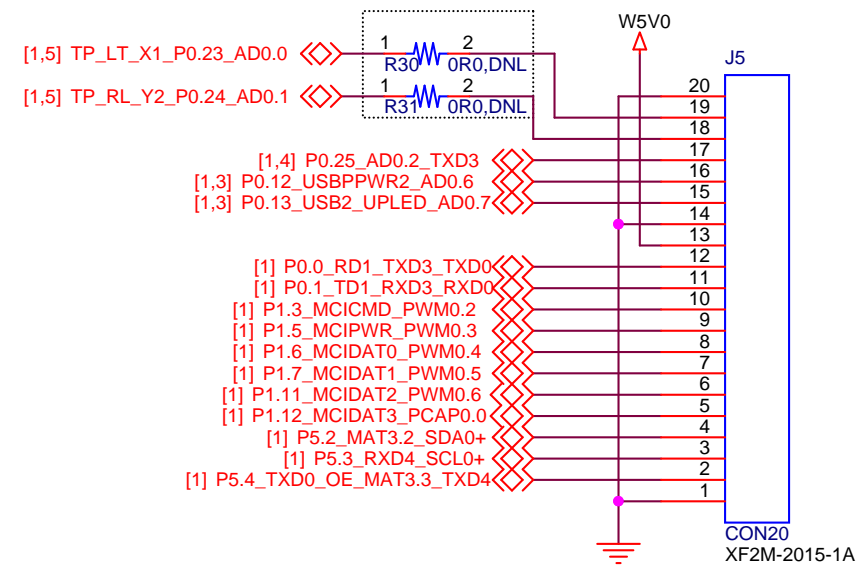

PRIMARY EXPANSION CONNECTOR

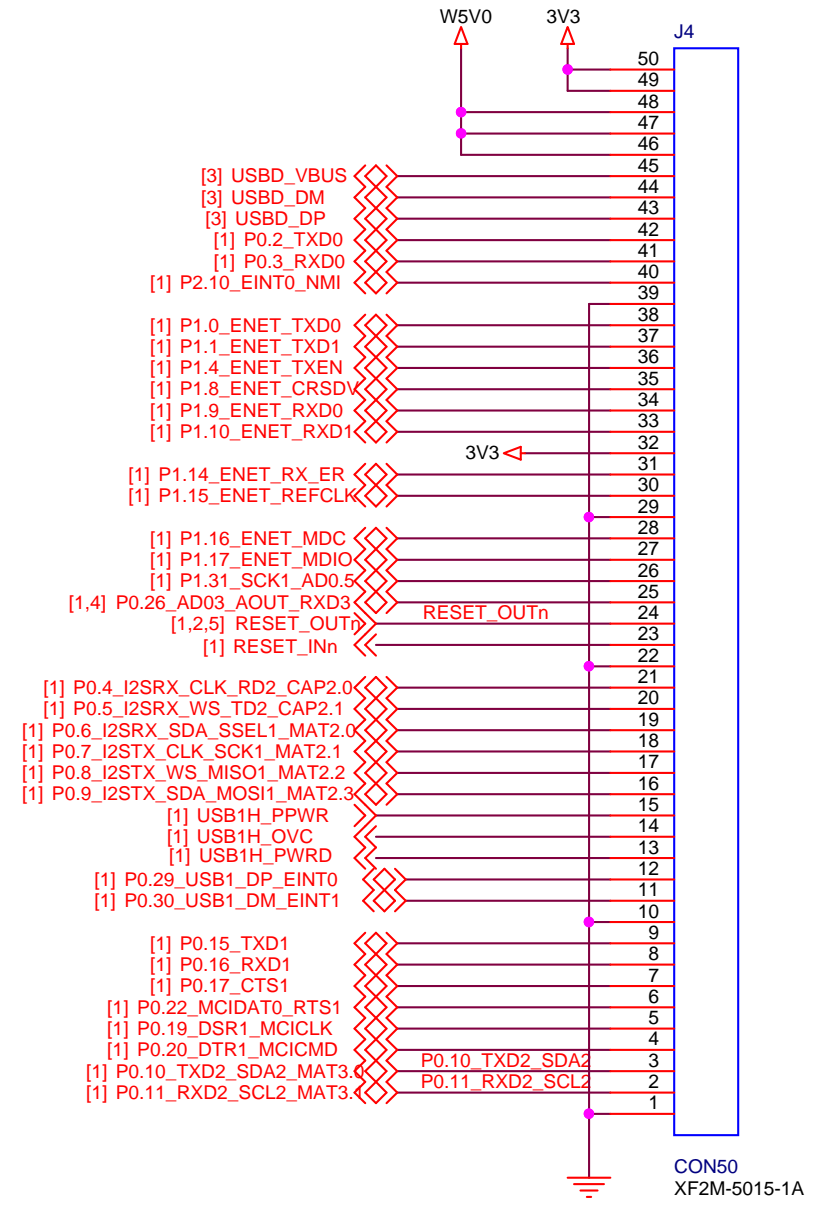

AMPLIFIER

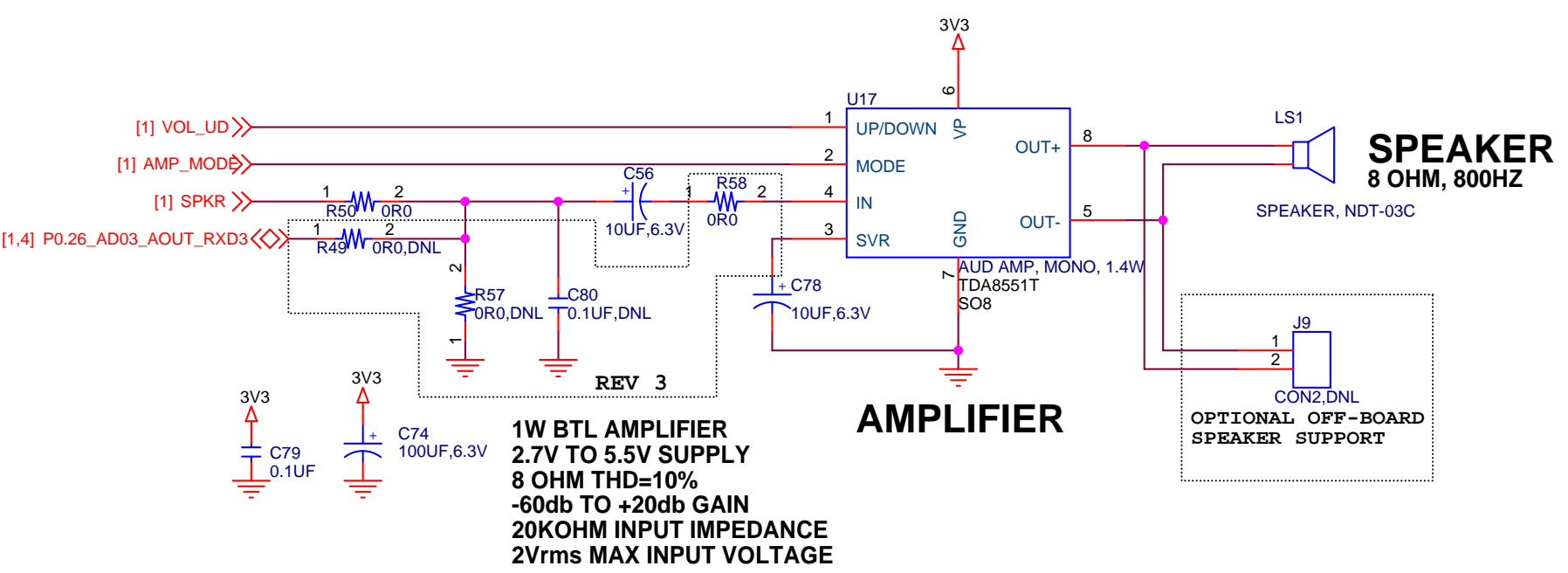

SPEAKER 8 OHM, 800HZ

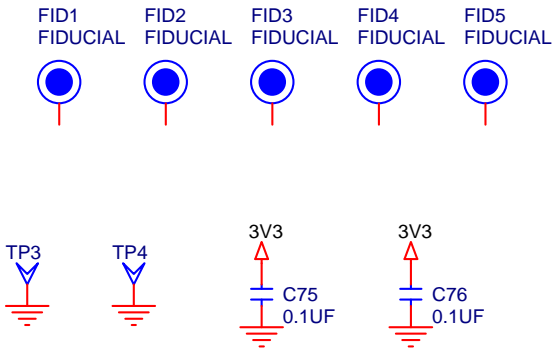
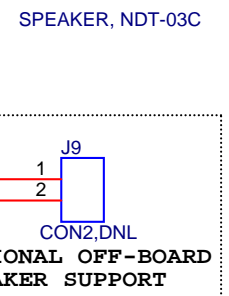

FUTURE DESIGNS, INC. 2702 TRIANA BLVD HUNTSVILLE, AL 35805		FDI
Title: VREG IO CONN SPKR		
Size: Document Number UEZGUI 7.0"	Rev: 3	
Date: Monday, March 19, 2012	Sheet: 4	of 5

