

CATALOG NUMBER	MATERIAL NUMBER	CONDUIT SIZE	N.P.T. FITTING SIZE	LENGTH "M"	DIAMETER "A" REF.	LENGTH "B" REF.	LENGTH "C" REF.	PRODUCT SELECTION NUMBER	UL LISTED	CSA APRVD
36440	1300960056	3/8"	1/2"	3.875±0.500 / 98.43±12.70	1.0 / 25	1.13 / 28.7	0.63 / 16.0	STB038P	Y E S	Y E S
36370	1300960034	1/2"	1/2"	4.625±0.500 / 117.48±12.70	1.2 / 30	1.25 / 31.8	0.63 / 16.0	STB050P		
36371	1300960036	3/4"	3/4"	5.750±0.500 / 146.05±12.70	1.4 / 36	1.50 / 38.1	0.63 / 16.0	STB075P		
36372	1300960037	1"	1"	7.000±0.500 / 177.80±12.70	1.7 / 43	1.81 / 45.9	0.75 / 19.1	STB100P		
36373	1300960038	1-1/4"	1-1/4"	8.125±1.000 / 206.38±25.40	2.0 / 51	2.31 / 58.7	0.63 / 16.0	STB125P		
36374	1300960039	1-1/2"	1-1/2"	9.250±1.000 / 234.95±25.40	2.5 / 64	2.63 / 66.8	0.63 / 16.0	STB150P		
36375	1300960040	2"	2"	11.500±1.000 / 292.10±25.40	3.0 / 76	3.19 / 81.0	0.69 / 17.5	STB200P		
37030	1300960065	2-1/2"	2-1/2"	11.250±1.000 / 285.75±25.40	3.6 / 91	3.94 / 100.1	1.06 / 26.9	STB250P		

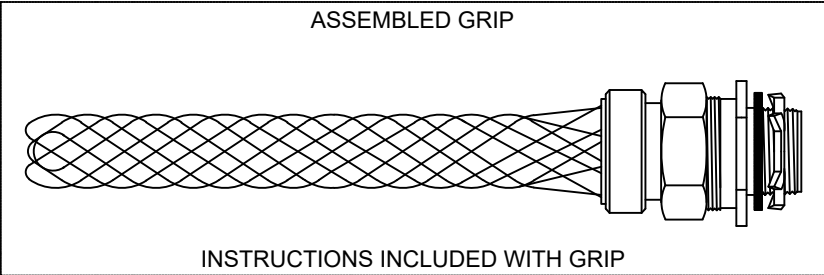
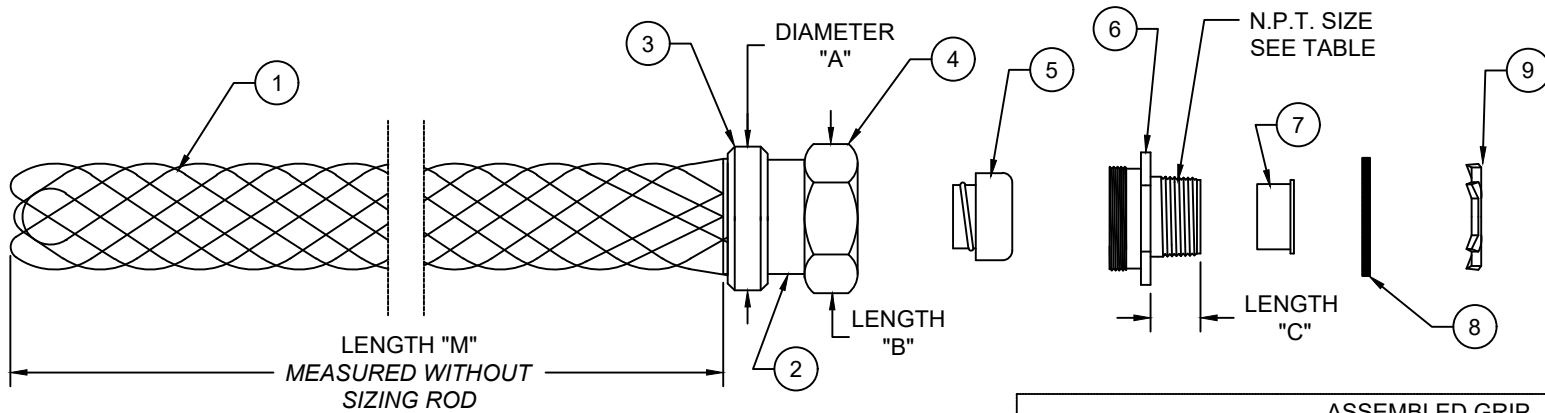

ITEM	DESCRIPTION	MATERIAL
1	WIRE MESH	STAINLESS STEEL
2	INNER RING	ZINC PLATED STEEL
3	OUTER RING	ALUMINUM
4	COMPRESSION NUT	ZINC PLATED STEEL OR MALLEABLE IRON
5	FERRULE	ZINC PLATED STEEL OR ALUMINUM
6	THREADED BODY	ZINC PLATED STEEL OR MALLEABLE IRON
7	THROAT INSULATION	PLASTIC
8	GASKET	NEOPRENE
9	LOCK NUT	ZINC PLATED STEEL

FUNCTIONAL SYMBOLS $F_A=0$ $F_C=0$ $F_F=0$ DIVISIONAL SYMBOLS	THIS DRAWING CONTAINS INFORMATION THAT IS PROPRIETARY TO MOLEX ELECTRONIC TECHNOLOGIES, LLC AND SHOULD NOT BE USED WITHOUT WRITTEN PERMISSION		CURRENT REV DESC: OBSOLETE PART NUMBER AS PER PCN#510808	
	DIMENSION UNITS	SCALE	EC NO: 736640	
	INCH/MM	NTS	DRWN: SUGEEB	2022/12/21
	GENERAL TOLERANCES (UNLESS SPECIFIED)		CHK'D: LIKITV	2023/02/14
	mm	INCH	APPR: GGA	2023/02/16
	4 PLACES ± ---- ± ----		INITIAL REVISION:	
	3 PLACES ± ---- ± 0.005		DRWN: HRUIZ01	2014/09/22
	2 PLACES ± 0.13 ± 0.01		APPR: JFMURPHY	2015/04/27
	1 PLACE ± 0.25 ± 0.02		THIRD ANGLE PROJECTION	
	0 PLACES ± ---- ± ----		DRAWING	
	ANGULAR TOL ± 0.5 °		SERIES	
DRAFT WHERE APPLICABLE MUST REMAIN WITHIN DIMENSIONS		A-SIZE		130096

		STRAIN RELIEF	
		LIQUID TIGHT CONDUIT STRAIGHT-MALE	
PRODUCT CUSTOMER DRAWING			
DOCUMENT NUMBER	DOC TYPE	DOC PART	REVISION
SD-130096-100	PSD	001	A1
MATERIAL NUMBER	CUSTOMER	SHEET NUMBER	
SEE TABLE	GENERAL MARKET	1 OF 1	