



**MICROCHIP**

---

**EV20F92A**  
**Serial Memory SPI**  
**Evaluation Kit User's Guide**

---

---

**Note the following details of the code protection feature on Microchip products:**

- Microchip products meet the specifications contained in their particular Microchip Data Sheet.
- Microchip believes that its family of products is secure when used in the intended manner, within operating specifications, and under normal conditions.
- Microchip values and aggressively protects its intellectual property rights. Attempts to breach the code protection features of Microchip product is strictly prohibited and may violate the Digital Millennium Copyright Act.
- Neither Microchip nor any other semiconductor manufacturer can guarantee the security of its code. Code protection does not mean that we are guaranteeing the product is “unbreakable”. Code protection is constantly evolving. Microchip is committed to continuously improving the code protection features of our products.

---

This publication and the information herein may be used only with Microchip products, including to design, test, and integrate Microchip products with your application. Use of this information in any other manner violates these terms. Information regarding device applications is provided only for your convenience and may be superseded by updates. It is your responsibility to ensure that your application meets with your specifications. Contact your local Microchip sales office for additional support or, obtain additional support at <https://www.microchip.com/en-us/support/design-help/client-support-services>.

THIS INFORMATION IS PROVIDED BY MICROCHIP "AS IS". MICROCHIP MAKES NO REPRESENTATIONS OR WARRANTIES OF ANY KIND WHETHER EXPRESS OR IMPLIED, WRITTEN OR ORAL, STATUTORY OR OTHERWISE, RELATED TO THE INFORMATION INCLUDING BUT NOT LIMITED TO ANY IMPLIED WARRANTIES OF NON-INFRINGEMENT, MERCHANTABILITY, AND FITNESS FOR A PARTICULAR PURPOSE, OR WARRANTIES RELATED TO ITS CONDITION, QUALITY, OR PERFORMANCE.

IN NO EVENT WILL MICROCHIP BE LIABLE FOR ANY INDIRECT, SPECIAL, PUNITIVE, INCIDENTAL, OR CONSEQUENTIAL LOSS, DAMAGE, COST, OR EXPENSE OF ANY KIND WHATSOEVER RELATED TO THE INFORMATION OR ITS USE, HOWEVER CAUSED, EVEN IF MICROCHIP HAS BEEN ADVISED OF THE POSSIBILITY OR THE DAMAGES ARE FORESEEABLE. TO THE FULLEST EXTENT ALLOWED BY LAW, MICROCHIP'S TOTAL LIABILITY ON ALL CLAIMS IN ANY WAY RELATED TO THE INFORMATION OR ITS USE WILL NOT EXCEED THE AMOUNT OF FEES, IF ANY, THAT YOU HAVE PAID DIRECTLY TO MICROCHIP FOR THE INFORMATION.

Use of Microchip devices in life support and/or safety applications is entirely at the buyer's risk, and the buyer agrees to defend, indemnify and hold harmless Microchip from any and all damages, claims, suits, or expenses resulting from such use. No licenses are conveyed, implicitly or otherwise, under any Microchip intellectual property rights unless otherwise stated.

For information regarding Microchip's Quality Management Systems, please visit [www.microchip.com/quality](http://www.microchip.com/quality).

**Trademarks**

The Microchip name and logo, the Microchip logo, Adaptec, AnyRate, AVR, AVR logo, AVR Freaks, BesTime, BitCloud, CryptoMemory, CryptoRF, dsPIC, flexPWR, HELDO, IGLOO, JukeBlox, KeeLoq, Kleer, LANCheck, LinkMD, maXStylus, maXTouch, MediaLB, megaAVR, Microsemi, Microsemi logo, MOST, MOST logo, MPLAB, OptoLyzer, PIC, picoPower, PICSTART, PIC32 logo, PolarFire, Prochip Designer, QTouch, SAM-BA, SenGenuity, SpyNIC, SST, SST Logo, SuperFlash, Symmetricom, SyncServer, Tachyon, TimeSource, tinyAVR, UNI/O, Vectron, and XMEGA are registered trademarks of Microchip Technology Incorporated in the U.S.A. and other countries.

AgileSwitch, APT, ClockWorks, The Embedded Control Solutions Company, EtherSynch, Flashtec, Hyper Speed Control, HyperLight Load, IntelliMOS, Libero, motorBench, mTouch, Powermite 3, Precision Edge, ProASIC, ProASIC Plus, ProASIC Plus logo, QuietWire, SmartFusion, SyncWorld, Temux, TimeCesium, TimeHub, TimePictra, TimeProvider, TrueTime, WinPath, and ZL are registered trademarks of Microchip Technology Incorporated in the U.S.A.

Adjacent Key Suppression, AKS, Analog-for-the-Digital Age, Any Capacitor, AnyIn, AnyOut, Augmented Switching, BlueSky, BodyCom, CodeGuard, CryptoAuthentication, CryptoAutomotive, CryptoCompanion, CryptoController, dsPICDEM, dsPICDEM.net, Dynamic Average Matching, DAM, ECAN, Espresso T1S, EtherGREEN, GridTime, IdealBridge, In-Circuit Serial Programming, ICSP, INICnet, Intelligent Paralleling, Inter-Chip Connectivity, JitterBlocker, Knob-on-Display, maxCrypto, maxView, memBrain, Mindi, MiWi, MPASM, MPF, MPLAB Certified logo, MPLIB, MPLINK, MultiTRAK, NetDetach, NVM Express, NVMe, Omniscient Code Generation, PICDEM, PICDEM.net, PICkit, PICTail, PowerSmart, PureSilicon, QMatrix, REAL ICE, Ripple Blocker, RTAX, RTG4, SAM-ICE, Serial Quad I/O, simpleMAP, SimpliPHY, SmartBuffer, SmartHLS, SMART-I.S., storClad, SQL, SuperSwitcher, SuperSwitcher II, Switchtec, SynchroPHY, Total Endurance, TSHARC, USBCheck, VariSense, VectorBlox, VeriPHY, ViewSpan, WiperLock, XpressConnect, and ZENA are trademarks of Microchip Technology Incorporated in the U.S.A. and other countries.

SQTP is a service mark of Microchip Technology Incorporated in the U.S.A.

The Adaptec logo, Frequency on Demand, Silicon Storage Technology, Symmcom, and Trusted Time are registered trademarks of Microchip Technology Inc. in other countries.

GestIC is a registered trademark of Microchip Technology Germany II GmbH & Co. KG, a subsidiary of Microchip Technology Inc., in other countries.

All other trademarks mentioned herein are property of their respective companies.

© 2022, Microchip Technology Incorporated and its subsidiaries.

All Rights Reserved.

ISBN: 978-1-6683-0431-0



# EV20F92A SERIAL MEMORY SPI EVALUATION KIT USER'S GUIDE

## Table of Contents

<b>Preface</b> .....	<b>5</b>
<b>Chapter 1. Product Overview</b>	
1.1 Introduction .....	9
1.2 EV20F92A Evaluation Kit Overview .....	9
1.3 Evaluation Kit Contents .....	9
1.4 Operational Requirements .....	10
<b>Chapter 2. Installation and Operation</b>	
2.1 Introduction .....	11
2.2 Installing the Graphical User Interface (GUI) .....	11
2.3 Microsoft Windows Desktop Runtime .....	13
2.4 Flexible In-System Programming (FLIP) Software .....	14
2.5 Evaluation Kit Setup Procedure .....	19
<b>Chapter 3. Graphical User Interface (GUI)</b>	
3.1 Introduction .....	20
3.2 Main Title Bar .....	21
3.3 Query Device .....	21
3.4 System Status .....	21
3.5 Device Conditions .....	22
3.6 Device Specification .....	23
3.7 Set Hardware Features .....	23
3.8 GUI Memory Array .....	24
3.9 Array Decode .....	24
3.10 Array Buttons .....	25
3.11 STATUS Register .....	29
3.12 Enhanced Write Protection .....	30
3.13 Security Register .....	31
3.14 Transaction Log .....	33
<b>Chapter 4. USB Base Board Firmware Update</b>	
4.1 Introduction .....	34
4.2 Using The GUI To Update The Firmware .....	34
4.3 Using The FLIP Software To Update The Firmware .....	34
4.4 FLIP Software Utility .....	36
<b>Chapter 5. Troubleshooting Guide</b>	
<b>Appendix A. Schematics</b>	
A.1 Introduction .....	40
A.2 SPI Socket Board (04-11160) .....	41

# **EV20F92A Serial Memory SPI Evaluation Kit User's Guide**

---

---

A.3 USB Base Board (02-10682) .....	42
<b>Appendix B. Bill of Materials (BOM)</b>	
<b>Worldwide Sales and Service .....</b>	<b>46</b>



# EV20F92A SERIAL MEMORY SPI EVALUATION KIT USER'S GUIDE

---

---

## Preface

---

---

### NOTICE TO CUSTOMERS

All documentation becomes dated and this manual is no exception. Microchip tools and documentation are constantly evolving to meet customer needs, so some actual dialogs and/or tool descriptions may differ from those in this document. Please refer to our website ([www.microchip.com](http://www.microchip.com)) to obtain the latest documentation available.

Documents are identified with a “DS” number. This number is located on the bottom of each page, in front of the page number. The numbering convention for the DS number is “DSXXXXXXXXA”, where “XXXXXXXX” is the document number and “A” is the revision level of the document.

For the most up-to-date information on development tools, see the MPLAB® X IDE online help. Select the Help menu and then Topics to open a list of available online help files.

## INTRODUCTION

This chapter contains general information that will be useful to know before using the EV20F92A Serial Memory SPI Evaluation Kit. Items discussed in this chapter include:

- Document Layout
- Conventions Used in This Guide
- Recommended Reading
- The Microchip Website
- Customer Support
- Revision History

## DOCUMENT LAYOUT

This document describes how to use the EV20F92A Serial Memory SPI Evaluation Kit as a tool to demonstrate the best-in-class features, functionality and low-power operation of Microchip's SPI Serial EEPROM devices.

The document is organized as follows:

- **Chapter 1. “Product Overview”**
- **Chapter 2. “Installation and Operation”**
- **Chapter 3. “Graphical User Interface (GUI)”**
- **Chapter 4. “USB Base Board Firmware Update”**
- **Chapter 5. “Troubleshooting Guide”**
- **Appendix A. “Schematics”**
- **Appendix B. “Bill of Materials (BOM)”**

# EV20F92A Serial Memory SPI Evaluation Kit User's Guide

## CONVENTIONS USED IN THIS GUIDE

This manual uses the following documentation conventions:

### DOCUMENTATION CONVENTIONS

Description	Represents	Examples
<b>Arial font:</b>		
Italic characters	Referenced books	<i>MPLAB<sup>®</sup> X IDE User's Guide</i>
	Emphasized text	...is the <i>only</i> compiler...
Initial caps	A window	the Output window
	A dialog	the Settings dialog
	A menu selection	select Enable Programmer
Quotes	A field name in a window or dialog	"Save project before build"
Underlined, Italic text with right angle bracket	A menu path	<u><i>File&gt;Save</i></u>
Bold characters	A dialog button	Click <b>OK</b>
	A tab	Click the <b>Power</b> tab
N'Rnnnn	A number in verilog format, where N is the total number of digits, R is the radix and n is a digit.	4'b0010, 2'hF1
Text in angle brackets < >	A key on the keyboard	Press <Enter>, <F1>
<b>Courier New font:</b>		
Plain Courier New	Sample source code	#define START
	Filenames	autoexec.bat
	File paths	c:\mcc18\h
	Keywords	_asm, _endasm, static
	Command-line options	-Opa+, -Opa-
	Bit values	0, 1
	Constants	0xFF, 'A'
Italic Courier New	A variable argument	<i>file.o</i> , where <i>file</i> can be any valid filename
Square brackets [ ]	Optional arguments	mcc18 [options] <i>file</i> [options]
Curly brackets and pipe character: {   }	Choice of mutually exclusive arguments; an OR selection	errorlevel {0 1}
Ellipses...	Replaces repeated text	var_name [, var_name...]
	Represents code supplied by user	void main (void) { ... }

## RECOMMENDED READING

This user's guide describes how to use the EV20F92A Serial Memory SPI Evaluation Kit. The following documents are available and recommended as supplemental reference resources.

- **Serial Memory SPI Quick Start Guide – “Serial Memory SPI Evaluation Kit Quick Start Guide” (DS20006415)** – This quick start guide provides a brief overview on the EV20F92A Evaluation Kit's functionalities, features and capabilities.

## THE MICROCHIP WEBSITE

Microchip provides online support via our website at [www.microchip.com](http://www.microchip.com). This website is used as a means to make files and information easily available to customers. Accessible by using your favorite Internet browser, the website contains the following information:

- **Product Support** – Data sheets and errata, application notes and sample programs, design resources, user's guides and hardware support documents, latest software releases and archived software
- **General Technical Support** – Frequently Asked Questions (FAQs), technical support requests, online discussion groups, Microchip consultant program member listing
- **Business of Microchip** – Product selector and ordering guides, latest Microchip press releases, listing of seminars and events, listings of Microchip sales offices, distributors and factory representatives

## DEVELOPMENT SYSTEMS CUSTOMER CHANGE NOTIFICATION SERVICE

Microchip's customer notification service helps keep customers current on Microchip products. Subscribers will receive e-mail notification whenever there are changes, updates, revisions or errata related to a specified product family or development tool of interest.

To register, access the Microchip website at [www.microchip.com](http://www.microchip.com), click on Customer Change Notification and follow the registration instructions.

The Development Systems product group categories are:

- **Compilers** – The latest information on Microchip C compilers, assemblers, linkers and other language tools. These include all MPLAB C compilers; all MPLAB assemblers (including MPASM™ assembler); all MPLAB linkers (including MPLINK™ object linker); and all MPLAB librarians (including MPLIB™ object librarian).
- **Emulators** – The latest information on Microchip in-circuit emulators. This includes the MPLAB REAL ICE™ and MPLAB ICE 2000 in-circuit emulators.
- **In-Circuit Debuggers** – The latest information on the Microchip in-circuit debuggers. This includes MPLAB ICD 3 in-circuit debuggers and PICKit™ 3 debug express.

# EV20F92A Serial Memory SPI Evaluation Kit User's Guide

---

- **MPLAB IDE** – The latest information on Microchip MPLAB X IDE, the Windows® Integrated Development Environment for development systems tools. This list is focused on the MPLAB X IDE, MPLAB X IDE Project Manager, MPLAB Editor and MPLAB SIM simulator, as well as general editing and debugging features.
- **Programmers** – The latest information on Microchip programmers. These include production programmers such as MPLAB REAL ICE in-circuit emulator, MPLAB ICD 3 in-circuit debugger and MPLAB PM3 device programmers. Also included are nonproduction development programmers such as PICSTART® Plus and PICkit 2 and 3.

## CUSTOMER SUPPORT

Users of Microchip products can receive assistance through several channels:

- Distributor or Representative
- Local Sales Office
- Field Application Engineer (FAE)
- Technical Support

Customers should contact their distributor, representative or field application engineer (FAE) for support. Local sales offices are also available to help customers. A listing of sales offices and locations is included in the back of this document.

Technical support is available through the website at:

<http://www.microchip.com/support>.

## REVISION HISTORY

### Revision A (06/2022)

- Initial release of this document.



---

---

## Chapter 1. Product Overview

---

---

### 1.1 INTRODUCTION

Microchip Technology's EV20F92A Serial Memory SPI Evaluation Kit allows the user to read, write and verify Microchip's Serial EEPROM devices using the SPI bus protocol.

This chapter introduces the EV20F92A Serial Memory SPI Evaluation Kit and provides an overview of its features. Topics covered include:

- EV20F92A Evaluation Kit Overview
- EV20F92A Evaluation Kit Contents
- Operational Requirements

### 1.2 EV20F92A EVALUATION KIT OVERVIEW

The Serial Memory SPI Evaluation Kit (EV20F92A) is an easy-to-use interactive user tool that demonstrates the best-in-class features, functionality and low-power operation of Microchip SPI Serial EEPROM devices. The included Graphical User Interface (GUI) makes it easy for engineers and developers to configure and evaluate SPI Serial EEPROMs, shortening the overall development time needed to bring new designs from prototype to production.

### 1.3 EVALUATION KIT CONTENTS

The Serial Memory SPI Evaluation Kit includes the following:

- SPI Socket Board (04-11160) (Figure 1-1)
- USB Base Board (02-10682) (Figure 1-2)
- Various loose Microchip SPI Serial EEPROM devices
- Important Information Sheet

**FIGURE 1-1: SPI SOCKET BOARD (04-11160)**

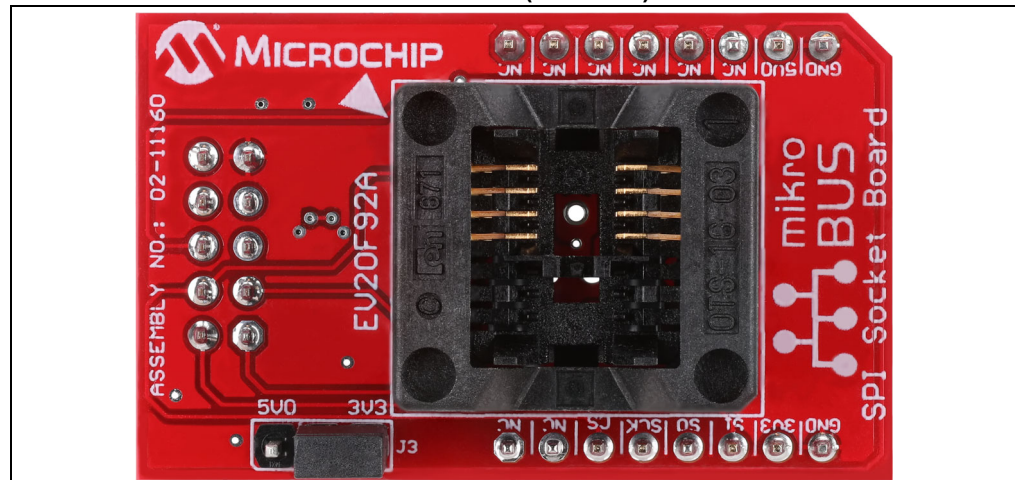
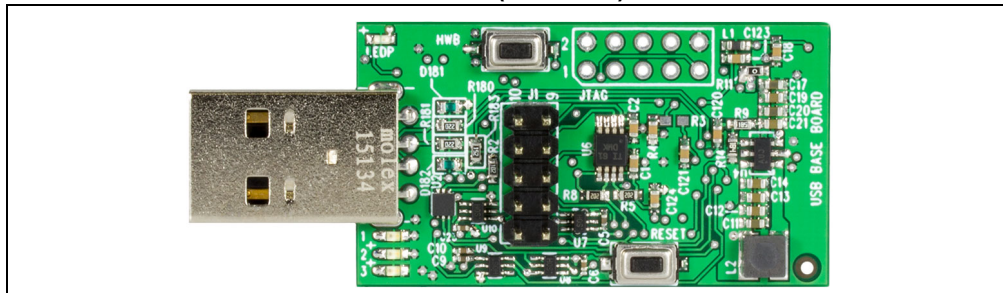


FIGURE 1-2: USB BASE BOARD (02-10682)



The SPI Socket Board also includes mikroBUS™ headers that allow the user to further develop applications by using the Socket Board with Microchip's extensive Development Tool offering. The VCC for the mikroBUS™ operation can be selected by the user by changing jumper on header J3 to select either 3.3V or 5.0V.

**Note:** By default the board is shipped with 3.3V selected by jumper installed in header J3 as shown in [Figure 1-1](#).

## 1.4 OPERATIONAL REQUIREMENTS

For the Serial Memory SPI Evaluation Kit to function properly, the following hardware and software requirements must be met:

- PC compatible system
- An available USB port on PC
- At least 77.4 MB of free disk space
- Windows® 10 64-bit operating system

---

---

## Chapter 2. Installation and Operation

---

---

### 2.1 INTRODUCTION

Setup for the Serial Memory SPI Evaluation Kit is straightforward. To start, the SPI Graphical User Interface (GUI) will need to be downloaded and installed on the user's PC. Note that the USB Base Board driver is also installed during the GUI installation process. Once installed, the user should perform a simple hardware setup sequence. Once completed, simply plug in the USB Base Board to an available USB port on the user's PC and launch the SPI GUI.

#### WARNING

**Read the EV20F92A Serial Memory SPI Evaluation Kit User's Guide (this document) fully before proceeding to evaluation kit setup.**

### 2.2 INSTALLING THE GRAPHICAL USER INTERFACE (GUI)

The following steps are needed to successfully install the GUI software:

**Note:** If an earlier version of the EV20F92A SPI Evaluation Kit GUI was previously installed, it is recommended to uninstall the previous version before installing the new version. This will ensure robust GUI operation.

1. Go to <http://www.microchip.com/EV20F92A> to download the GUI software.
2. Navigate to *Documentation and Software* and select the *EV20F92A SPI Evaluation Kit GUI* software.
3. Download and open the setup file:  
EV20F92A\_x.x.x\_setup.exe, where x.x.x indicates the GUI version.
4. If the Open File – Security Warning pops up, press the **Run** button.

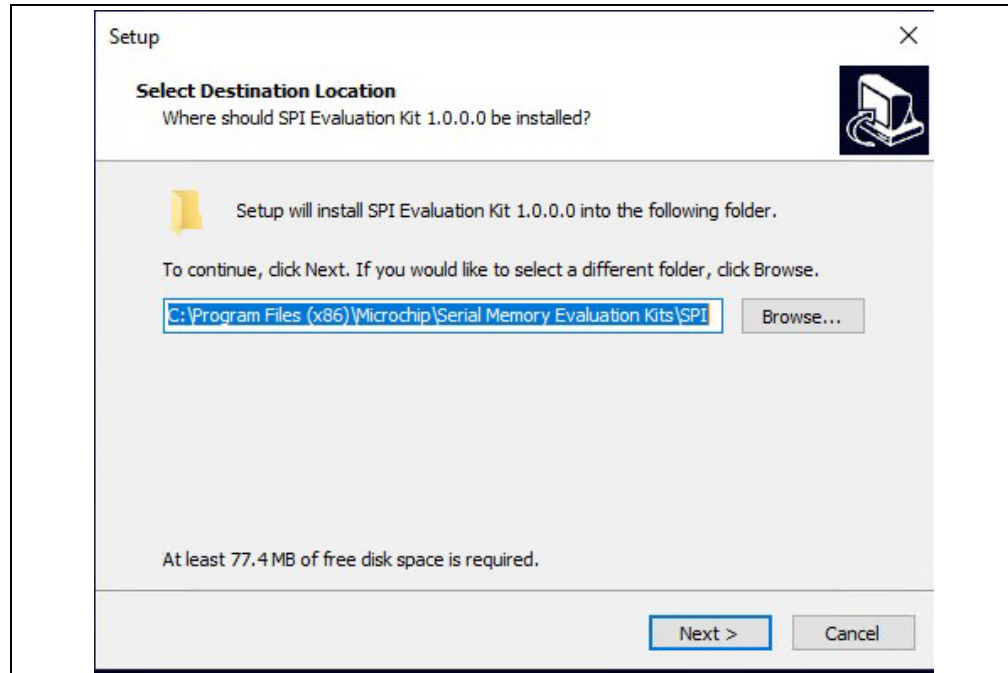
**Note:** If prompted, allow the program to make changes to your PC.

5. Select the Installation Destination Location from the GUI. Press the **Next** button when ready ([Figure 2-1](#)). The default Destination Location is:

C:\Program Files (x86)\Microchip\Serial Memory Evaluation Kits\SPI

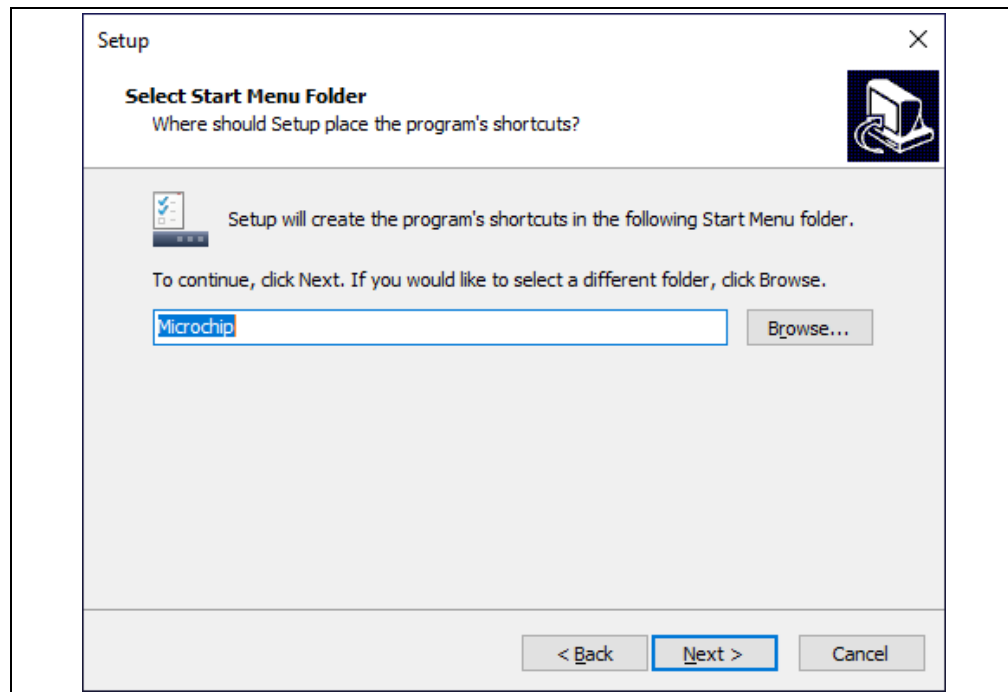
**Note:** When referring to location of files on the user's PC, this document is assuming that the default installation was used when the GUI was installed. If the default installation is not used, it is the user's responsibility to determine the reference file location.

FIGURE 2-1: GUI INSTALLATION LOCATION



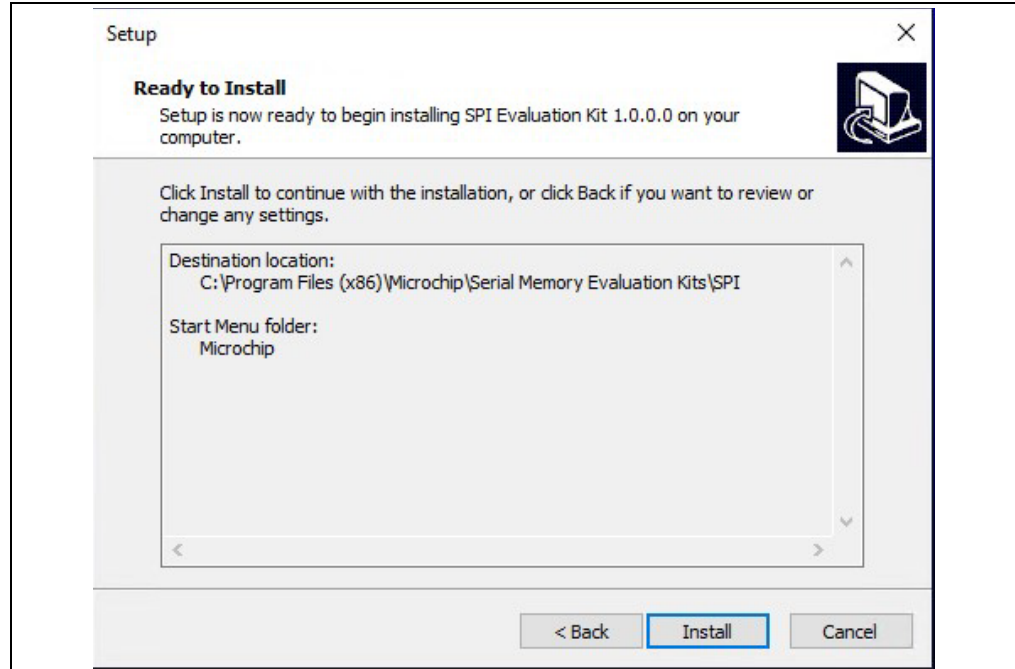
6. The next step is to select the Start Menu folder. By default, the setup will create a Start Menu folder named *Microchip* (if one is not already present on the user's PC). Press the **Next** button when ready to continue (Figure 2-2).

FIGURE 2-2: GUI START MENU FOLDER



7. Once the Destination location and the Start Menu folder have been selected, the setup will prompt the user if they are ready to install the software. Press the **Install** button when ready (Figure 2-3) and, once complete, the installation will then install the various drivers. Follow the on-screen instructions to complete driver installation.

**FIGURE 2-3: GUI READY TO INSTALL**



## 2.3 MICROSOFT WINDOWS DESKTOP RUNTIME

The Microchip Technology Serial Memory SPI Evaluation Kit requires that .NET 5.0 or higher is installed on the user's PC for running WPF applications. Follow the on-screen instructions and complete the .NET installation. Once complete, the installation will then install the FLIP software.:

**Note:** If .NET Desktop Runtime is already installed on the user's PC, it is recommended, the user exits the .NET installation by pressing the **Close** button.

## 2.4 FLEXIBLE IN-SYSTEM PROGRAMMING (FLIP) SOFTWARE

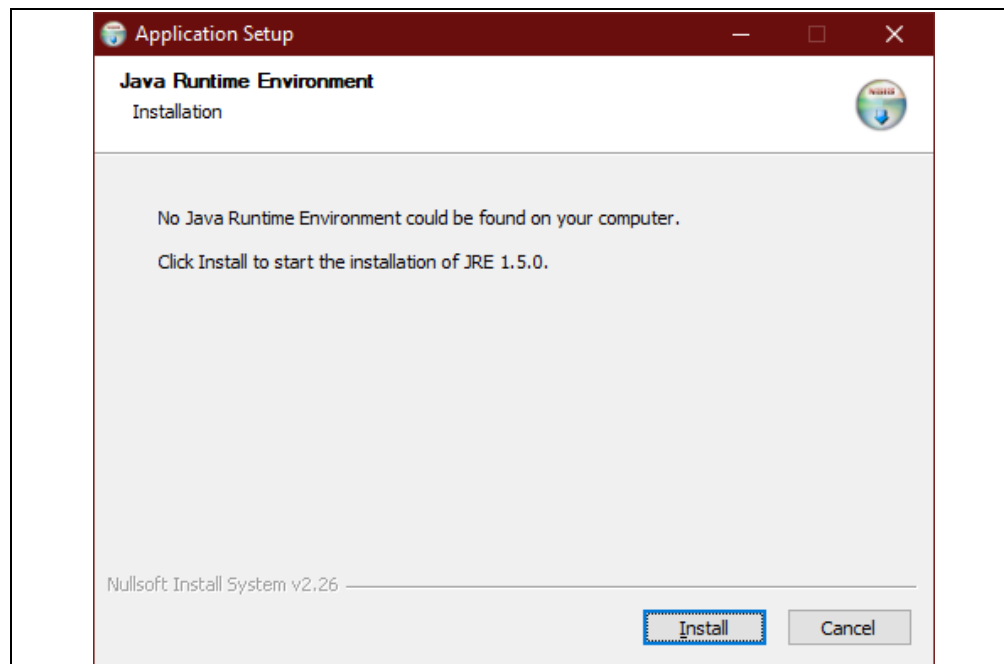
The Microchip Technology Serial Memory Evaluation Kits have a built-in ability to update the USB Base Board using a sequence of steps, along with using the Atmel FLEXible In-system Programming (FLIP) software.

The following steps are needed to successfully install the FLIP Software Utility:

1. If Java Runtime is already installed or a newer version is already installed, the setup will automatically start and you may skip to [Step 7](#). If no Java Runtime or an older version is present on the user's PC, when prompted, press the **Install** button to start the Java Runtime installation.

**Note:** If prompted, allow the program to make changes to your PC.

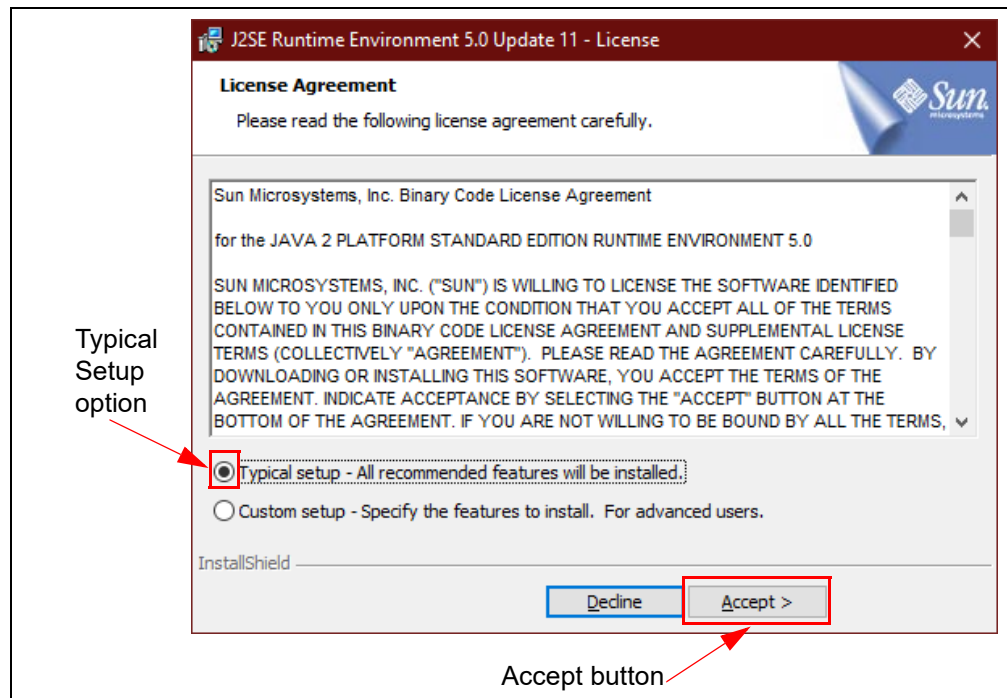
**FIGURE 2-4: JAVA RUNTIME ENVIRONMENT SETUP**



2. Allow the program to setup the Java Runtime. When prompted, select "Typical setup" and press the **Accept** button to accept the License Agreement.

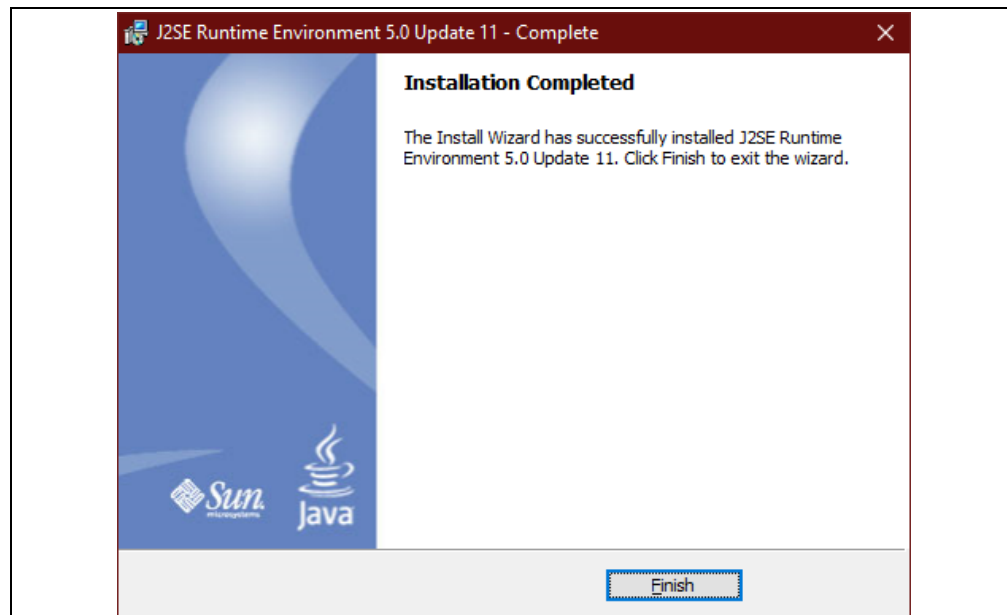
**Note:** For this example, the "Typical setup" was used. If the user selects a "Custom setup", it is the user's responsibility to ensure the FLIP Software Utility is installed correctly.

**FIGURE 2-5: JAVA RUNTIME TYPICAL SETUP**



3. Let the program setup the Java Runtime. A progress or status bar is included to show the overall progress of the installation. Once completed, press the **Finish** button to complete the Java Runtime installation.

**FIGURE 2-6: JAVA RUNTIME COMPLETION**



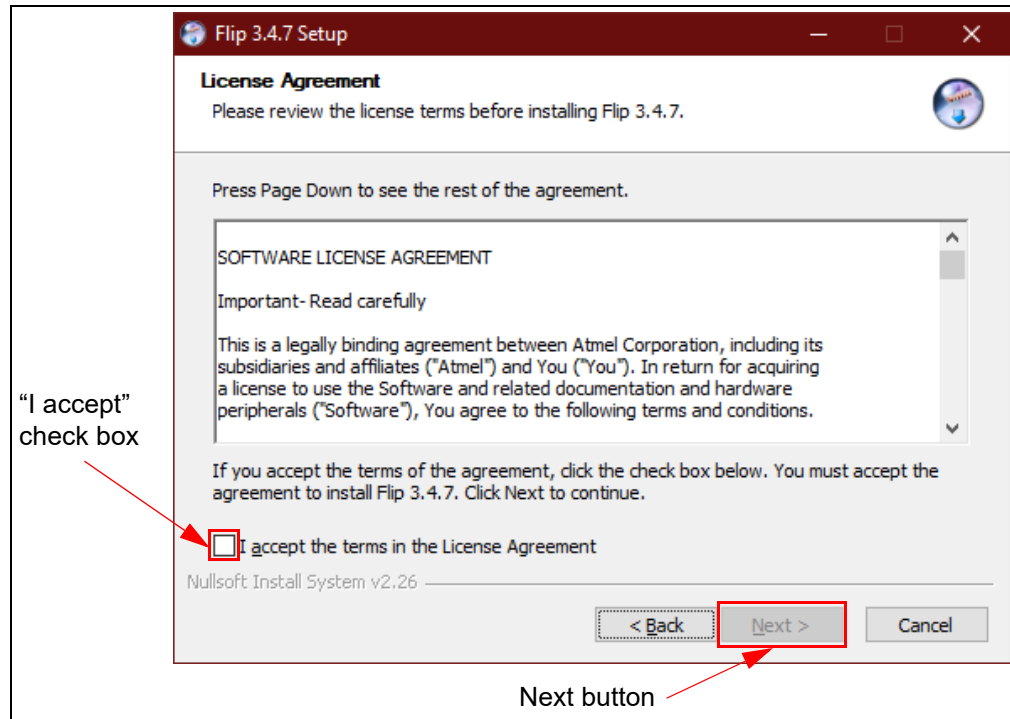
4. Once the Java Runtime is installed, the FLIP 3.4.7 Setup Wizard is automatically started. Once ready, click the **Next** button to continue.

**FIGURE 2-7: FLIP SETUP WIZARD**



5. Read the License Agreement. When finished, accept the terms in the License Agreement by checking the box and press the **Next** button to continue.

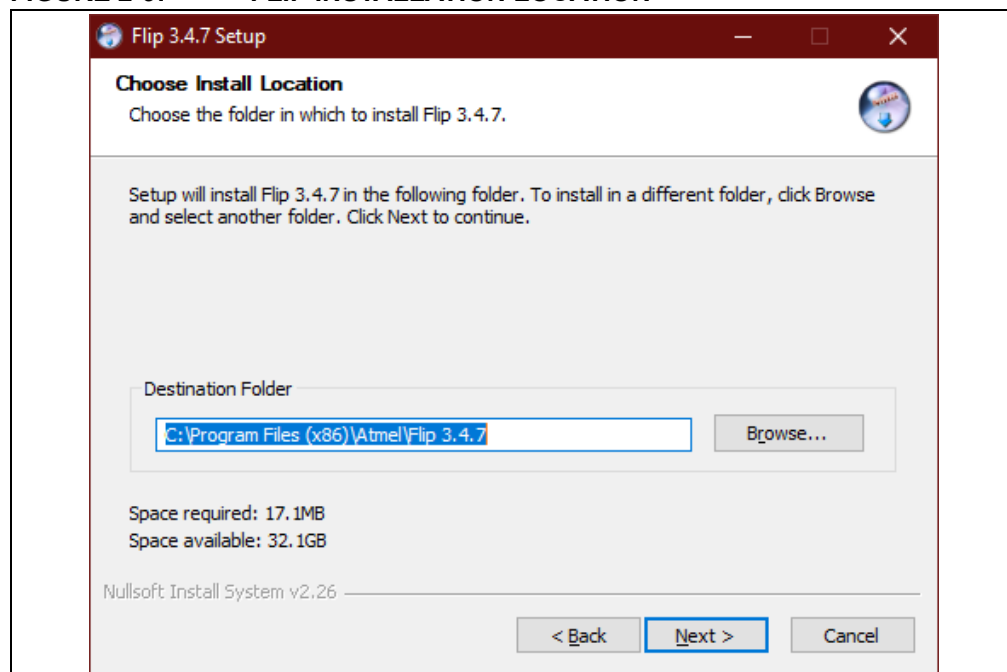
**FIGURE 2-8: FLIP LICENSE AGREEMENT**



6. Next, select the installation location. The default installation location is set to C:\Program Files (x86)\Atmel\FliP 3.4.7 (3.4.7 indicates the version). It is recommended that the default installation location is used. Once the installation location has been selected, press the **Next** button.

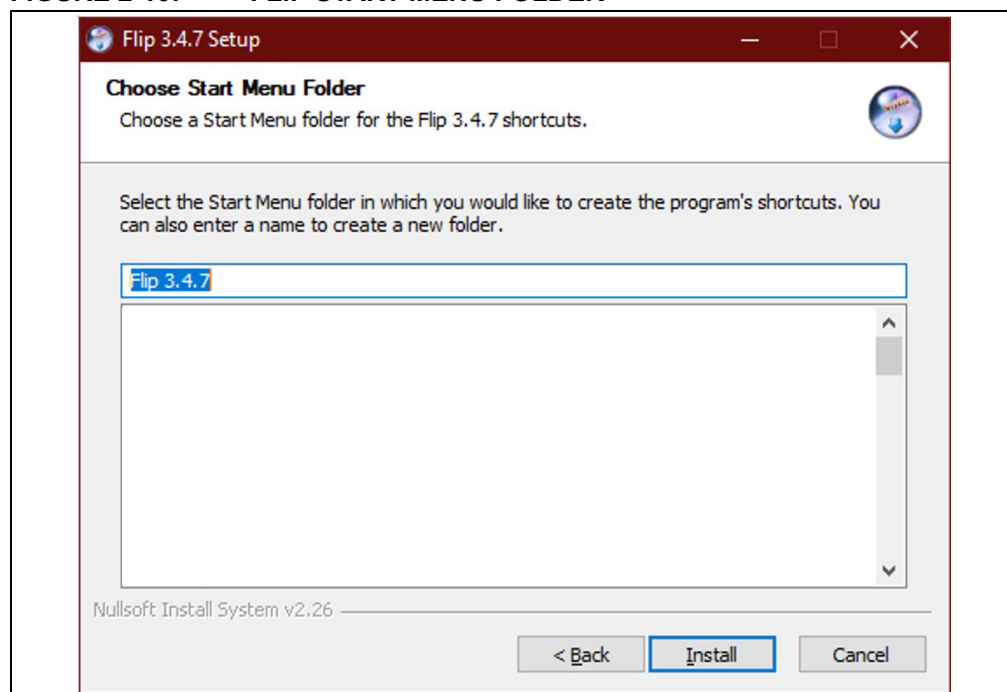


FIGURE 2-9: FLIP INSTALLATION LOCATION



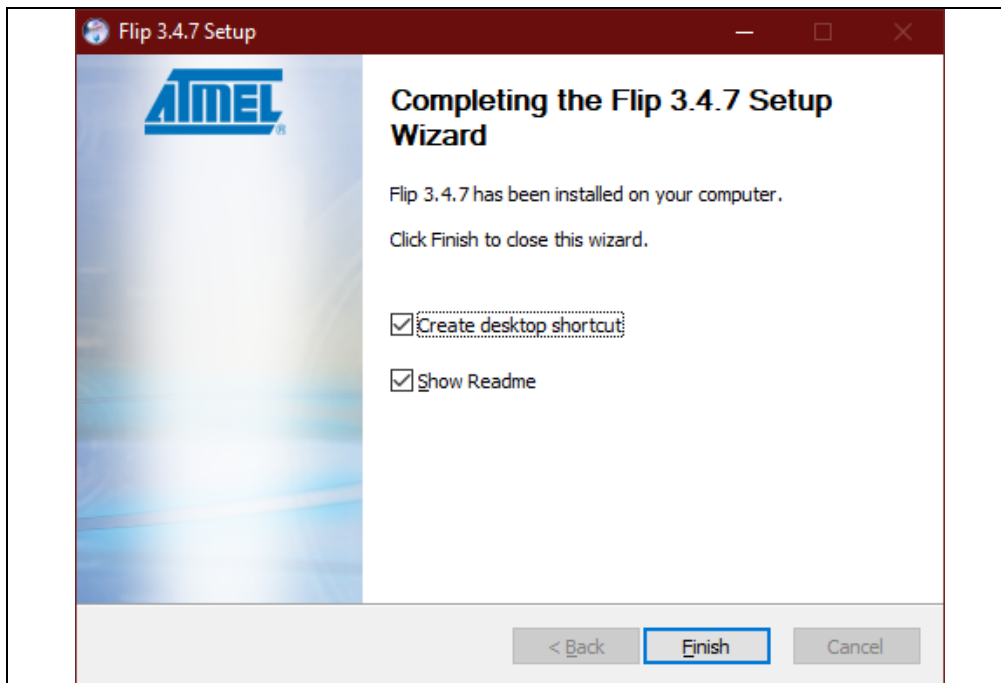
7. Choose a Start Menu folder. By default, the Start Menu folder is set to *Flip 3.4.7*, where 3.4.7 indicates the FLIP version. It is recommended that the default Start Menu folder is used. Once ready, press the **Install** button to continue.

FIGURE 2-10: FLIP START MENU FOLDER



8. Let the program setup the FLIP Software Utility. A progress or status bar is included to show the overall progress of the installation. Click the **Next** button during the installation progress, if prompted. Once completed, press the **Finish** button to complete the FLIP Software Utility installation.

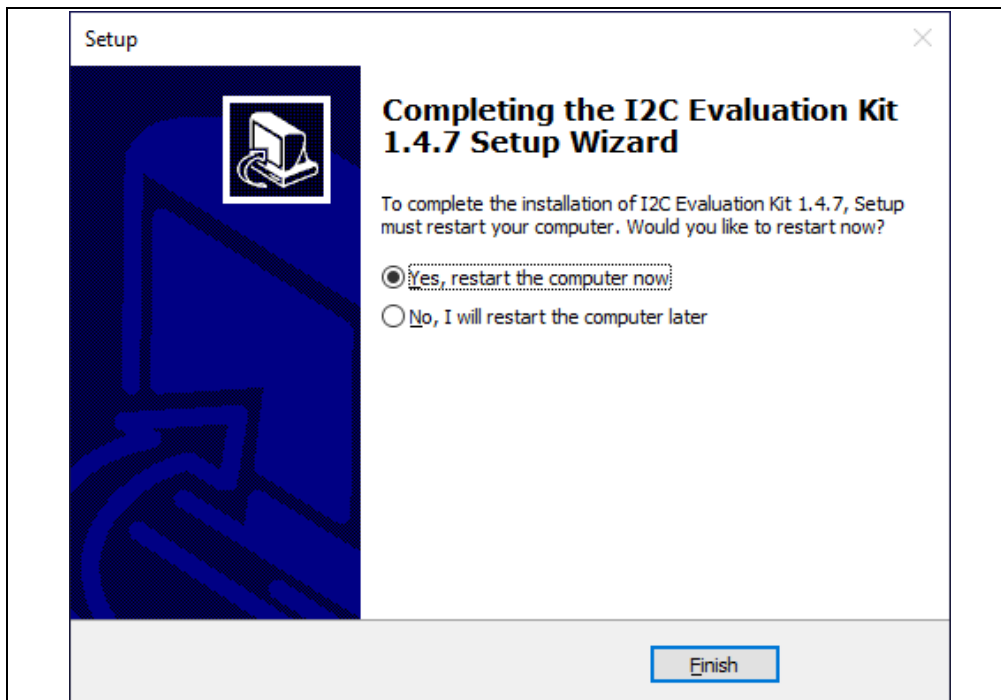
FIGURE 2-11: FLIP SOFTWARE UTILITY COMPLETE



9. Let the program setup the SPI GUI. A progress or status bar is included to show the overall progress of the installation. Once completed, press the **Finish** button to complete the SPI GUI installation and restart the computer (Figure 2-12).

**Note:** A Restart of the user's computer is needed in order to correctly setup the PATH variable. Failure to perform restart before starting GUI can cause erratic behavior

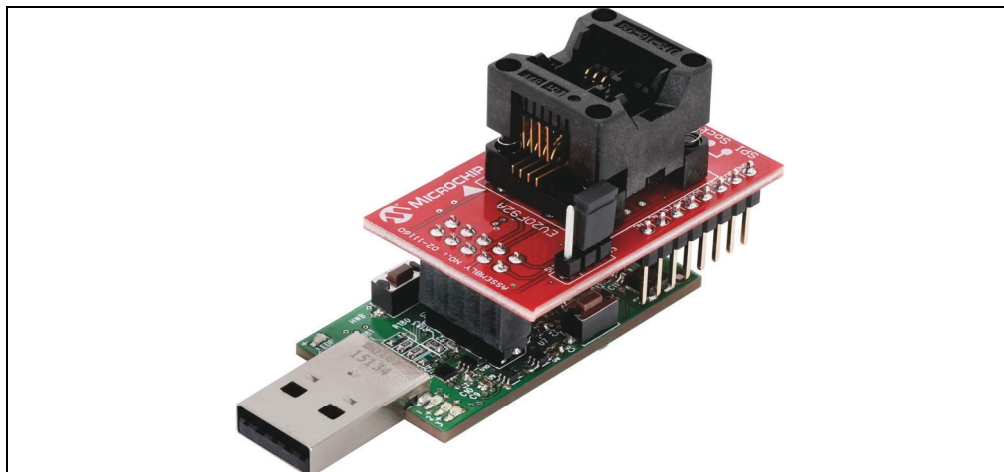
FIGURE 2-12: GUI INSTALLATION COMPLETE



## 2.5 EVALUATION KIT SETUP PROCEDURE

In order to start using the evaluation kit, simply plug the SPI Socket Board into the USB Base Board using the H1 and J1 headers. See [Figure 2-13](#) for illustration.

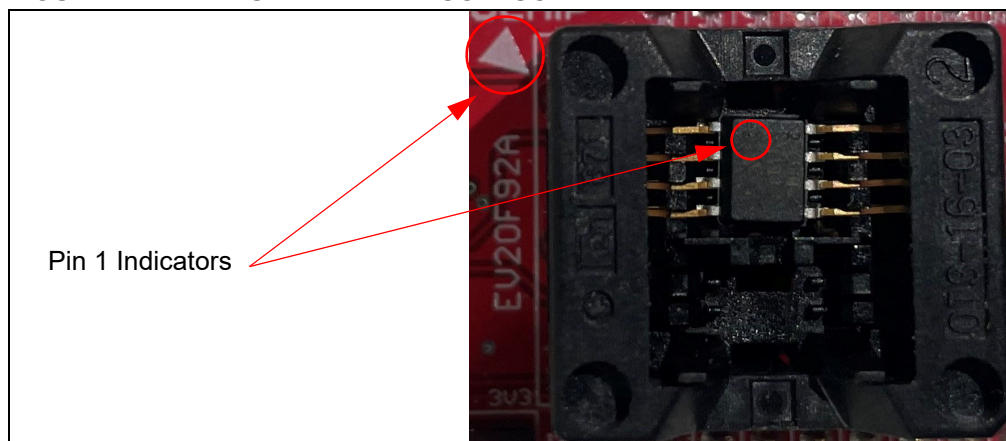
**FIGURE 2-13: USB BASE BOARD AND SPI SOCKET BOARD**



Once both boards are connected, verify that there is a device correctly installed in the SOIC socket on the SPI Socket Board, making sure to note that the Pin 1 indicator on the PCB matches the Pin 1 indicator on the SPI device. To ensure robust GUI and hardware operation, it is recommended that when installing a device, the USB Base Board be disconnected from the user's PC. [Figure 2-14](#) illustrates an SPI device that is properly seated in the SOIC socket and highlights the pin 1 indicator on the PCB.

**Note:** Due to the small size of the 8-lead SOIC package, it is recommended to use tweezers in order to properly install the device into the SPI Socket Board socket.

**FIGURE 2-14: SPI DEVICE IN SOIC SOCKET**



Once a device is installed in the SOIC socket, the user can then plug the USB Base Board into one of their computer's USB ports. Once the USB Base Board enumerates on the user's PC, open the GUI by selecting either the desktop icon (SPI GUI) or navigating to the Start Menu folder that was created when the EV20F92A SPI Evaluation Kit GUI software was installed.

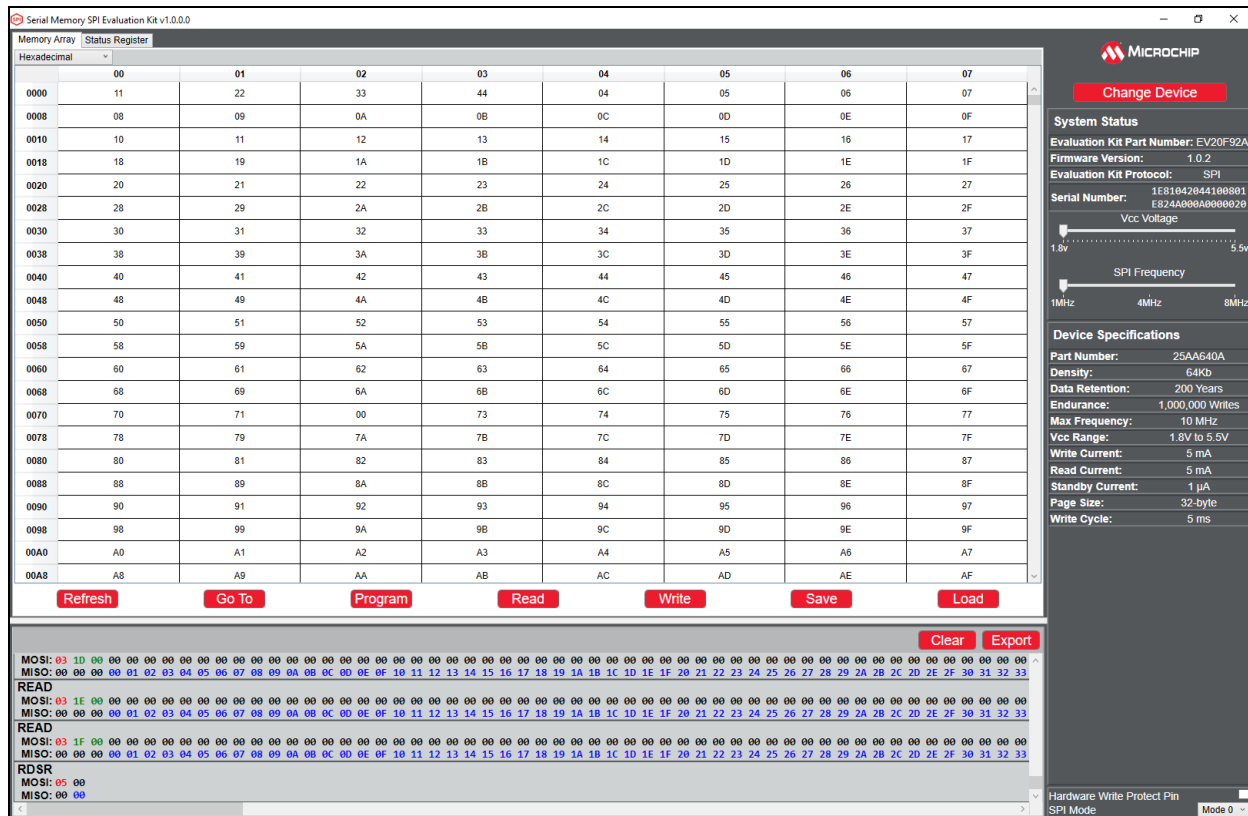
## Chapter 3. Graphical User Interface (GUI)

### 3.1 INTRODUCTION

The Serial Memory SPI Evaluation Kit includes a Graphical User Interface (GUI) which is used as an interface between the user's PC and the evaluation kit hardware. The GUI allows the user to easily interact with the SPI Serial EEPROM using built-in read and write features. The GUI also highlights the value-added features of the installed supported device. In the subsequent sections, the GUI features and functions are explained in detail to help the user to interact with the installed SPI Serial EEPROM.

The GUI detects the USB Base Board firmware version and determines whether it is compatible with that GUI version. If the GUI determines the USB Base Board firmware is incompatible, the GUI will try to update the firmware using a sequence of on-screen steps. Alternatively, this process can be done manually by the user if he or she chooses. Refer to the [Chapter 4. "USB Base Board Firmware Update"](#) for details on the firmware update process. If the GUI version is earlier than the USB Base Board, download the latest version of the GUI (refer to [Section 2.2 "Installing the Graphical User Interface \(GUI\)"](#) for additional information).

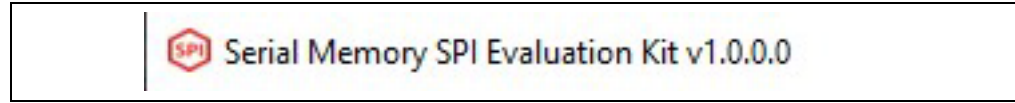
**FIGURE 3-1: GRAPHICAL USER INTERFACE**



## 3.2 MAIN TITLE BAR

The title bar displays the GUI version and the USB Base Board connection status. [Figure 3-2](#), shown below, illustrates a GUI version of 1.0.0.0.

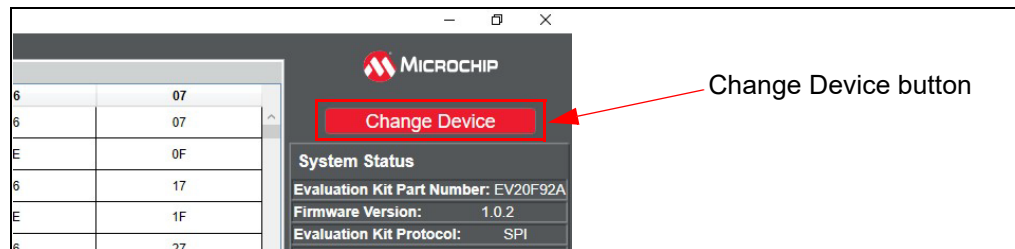
**FIGURE 3-2: TITLE BAR**



## 3.3 QUERY DEVICE

The GUI will perform an auto-query when the GUI is launched or when the USB Base Board is initially connected to the PC. Afterwards, the user can initiate a device query at any time with the **Change Device** button ([Figure 3-3](#)). Querying the device will populate or repopulate the GUI with the content read from the installed device.

**FIGURE 3-3: QUERY DEVICE**



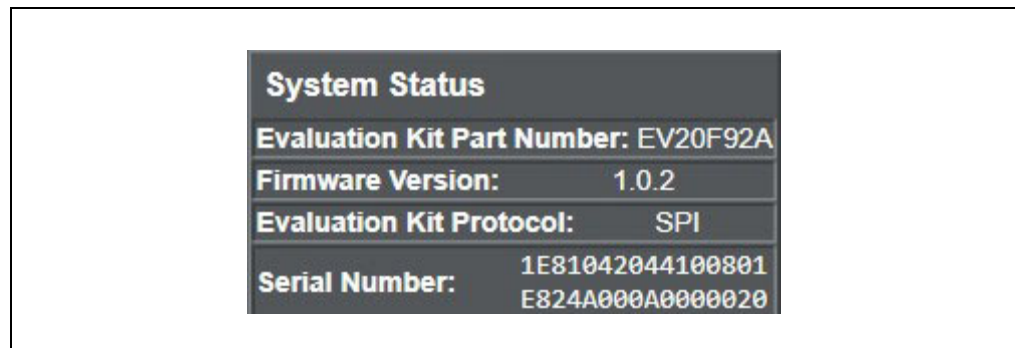
**FIGURE 3-4: PROGRESS BAR**



## 3.4 SYSTEM STATUS

The System Status pane is populated with information related to the evaluation kit hardware. These include the "Evaluation Kit Part Number", "Firmware Version", the "Evaluation Kit Protocol" and the "Serial Number".

**FIGURE 3-5: SYSTEM STATUS PANE**



### 3.4.1 Evaluation Kit Part Number

This displays the evaluation kit part number, EV20F92A.

### 3.4.2 Firmware Version

This is the version of the firmware programmed in the USB Base Board.

### 3.4.3 Evaluation Kit Protocol

Identifies the communication protocol used by the evaluation kit's socket board.

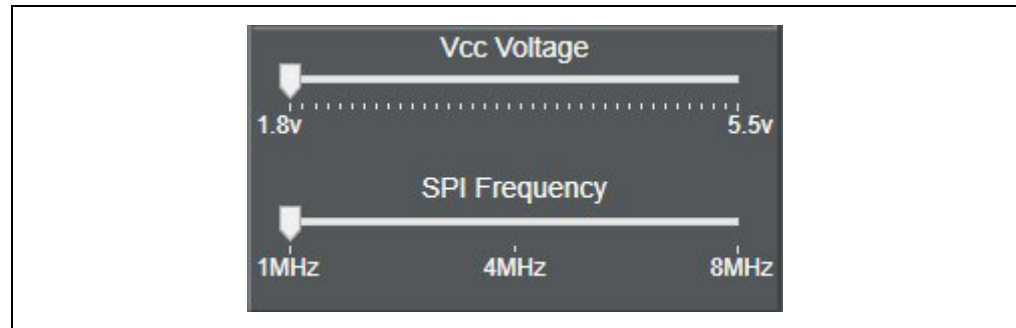
### 3.4.4 Serial Number

The SPI Socket Board serial number is retrieved from the AT24CS02 serialized Serial EEPROM located on the SPI Socket Board. Every SPI Socket Board will have its own unique serial number.

## 3.5 DEVICE CONDITIONS

The Device Conditions pane ([Figure 3-6](#)) allows the user to set the supply voltage to the SPI Socket Board and the communication speed or frequency of the SPI protocol.

**FIGURE 3-6: DEVICE CONDITIONS PANE**



### 3.5.1 Supply Voltage Slider

The voltage slider provides the ability to change the supply voltage, in 100 mV increments, to the SPI Socket Board, including the installed device VCC voltage. The user can change the VCC by either clicking along the slider or dragging the indicator to the desired VCC. The upper and lower limits of the VCC are determined by the installed device specification. Because the supply voltage is common between every device on the SPI Socket Board, a test point is included to measure VCC. Whenever the GUI is initially started or a Device Query is performed, the voltage slider will default to the lowest supported VCC of the installed device.

### 3.5.2 Frequency Slider

The frequency slider provides the ability to change the frequency communication speed between the host controller (USB Base Board) and the installed device. The user can change the speed by either clicking along the slider or dragging the indicator to the desired frequency. The upper frequency limit of the communication speed slider is determined by the installed device specification. Whenever the GUI is initially started or a Device Query is performed, the frequency slider will default to 1 MHz to ensure the installed supported device is able to communicate with the host controller.



## 3.6 DEVICE SPECIFICATION

The Device Specification pane (Figure 3-7) displays key device parameters that can be found in the installed device's data sheet.

**FIGURE 3-7: DEVICE SPECIFICATION PANE**

Device Specifications	
Part Number:	25CSM04
Density:	4Mb
Data Retention:	100 Years
Endurance:	1,000,000 Writes
Max Frequency:	8 MHz
Vcc Range:	2.5V to 5.5V
Write Current:	3 mA
Read Current:	3 mA
Standby Current:	2 $\mu$ A
Page Size:	256-byte
Write Cycle:	5 ms
Security Register:	512
Partition Registers:	8
Supports JEDEC ID:	Yes

## 3.7 SET HARDWARE FEATURES

The Set Hardware Features pane (Figure 3-8) allows the user to modify various hardware features for the supported device. These include asserting and de-asserting the hardware Write-Protect Pin and changing between using Mode 0 or Mode 1 for SPI protocol.

**FIGURE 3-8: SET HARDWARE FEATURES PANE**

Hardware Write Protect Pin	<input type="checkbox"/>
SPI Mode	Mode 0 <span>▾</span>

## 3.8 GUI MEMORY ARRAY

The GUI memory array is initially populated with the data read from the installed Serial EEPROM. The data of the GUI memory array is organized in 8-byte rows, left to right and in ascending order. The GUI memory array will always be displayed in 8-byte row lengths, regardless of the installed device's page size. The GUI memory array data can be modified by the user by using various GUI features that are outlined later in the subsequent sections.

The GUI memory array features memory cell font coloring that is used to highlight the different state of that memory cell or cells. *Black* font indicates the user can write to that word address or range of word addresses. *Green* font indicates that the memory array cell or cells have been changed in the internal GUI buffer and have not been written to the Serial EEPROM (see [Section 3.10.3 "Program"](#) for additional information).

**FIGURE 3-9: MEMORY ARRAY**

	00	01	02	03	04	05	06	07
0000	11	22	33	44	04	05	06	07
0008	08	09	0A	0B	0C	0D	0E	0F
0010	10	11	12	13	14	15	16	17
0018	18	19	1A	1B	1C	1D	1E	1F
0020	20	21	22	23	24	25	26	27
0028	28	29	2A	2B	2C	2D	2E	2F
0030	30	31	32	33	34	35	36	37
0038	38	39	3A	3B	3C	3D	3E	3F
0040	40	41	42	43	44	45	46	47
0048	48	49	4A	4B	4C	4D	4E	4F
0050	50	51	52	53	54	55	56	57
0058	58	59	5A	5B	5C	5D	5E	5F
0060	60	61	62	63	64	65	66	67
0068	68	69	6A	6B	6C	6D	6E	6F
0070	70	71	72	73	74	75	76	77
0078	78	79	7A	7B	7C	7D	7E	7F
0080	80	81	82	83	84	85	86	87
0088	88	89	8A	8B	8C	8D	8E	8F
0090	90	91	92	93	94	95	96	97
0098	98	99	9A	9B	9C	9D	9E	9F
00A0	A0	A1	A2	A3	A4	A5	A6	A7
00A8	A8	A9	AA	AB	AC	AD	AE	AF

The user can change the content of a cell by double clicking a word address or memory cell in the GUI memory array. In order to change the content of a cell, the user should update the value, followed by either selecting another cell or clicking anywhere else in the GUI, or by pressing Enter on the user's keyboard. Once the cell is updated, the cell font will become *green*. This indicates to the user that they must program the device using the Program Feature (see [Section 3.10.3 "Program"](#) for additional information).

## 3.9 ARRAY DECODE

Array decode allows the user to manipulate the GUI memory array in terms of how the data is decoded (Hexadecimal, Octal, Binary, ASCII or UTF-8).

**FIGURE 3-10: ARRAY DECODE**

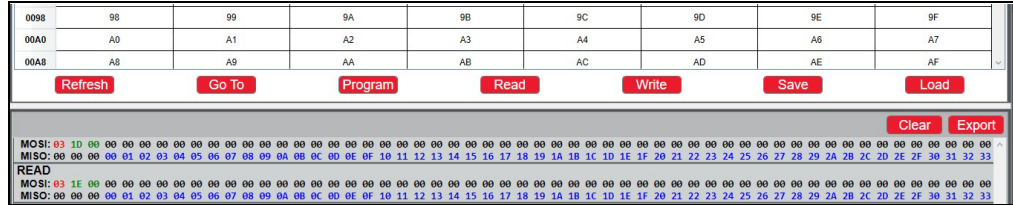
	Memory Array	Status Register
	Hexadecimal	
	Hexadecimal	00 01
	Octal	11 22
	Binary	08 09
	ASCII	
	UTF-8	
0010	10	11
0018	18	19
0020	20	21
0028	28	29



## 3.10 ARRAY BUTTONS

The array buttons, which are located below the GUI Security register, allow the user to perform read and write operations to the Serial EEPROM, navigate to specific word addresses in the GUI memory array and also provides various support functions.

**FIGURE 3-11: ARRAY BUTTONS**

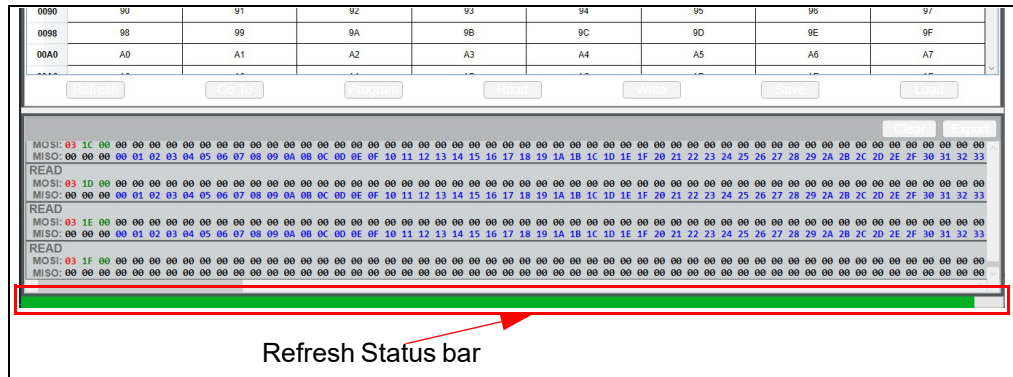


### 3.10.1 Refresh

The **Refresh** button reads the Serial EEPROM memory array of the installed device and then populates the GUI memory array with that data. If there is data in the internal GUI buffer (*green* font in cell) when the Refresh feature is used, that data will be replaced with the data read from the Serial EEPROM. After the completion of any write operation to the Serial EEPROM, the GUI will automatically update the GUI memory array and Security register using the Refresh feature.

**Note:** If a new device is installed while leaving the USB Base Board connected to the user's PC, it is recommended to use the Device Query feature instead of the Refresh feature to ensure robust GUI operation.

**FIGURE 3-12: REFRESH**



### 3.10.2 Go To Address

The Go To Address feature allows the user to jump to a specific word address in the GUI memory array.

**Note:** The Go To Address feature only works for addresses within the GUI memory array.

**FIGURE 3-13: GO TO ADDRESS**



### 3.10.3 Program

The Program feature can be used to write the GUI array buffer to the installed Serial EEPROM memory array. When the **Program** button is pressed, the current internal GUI buffer will be written to the Serial EEPROM memory. The Program feature must be used when a cell is updated (*green* font), or when a file (.hex or .txt) is loaded. If the Program feature is not used, the data in the internal GUI buffer will not be written to the installed Serial EEPROM.

When the Program feature is used to program the Serial EEPROM memory array, that entire memory region will be written with the current data in the internal GUI buffer rather than only the changed values. If a specific data byte or bytes are to be programmed, it is recommended to use the Write feature by pressing the **Write** button (see [Section 3.10.5 “Write”](#) for additional information).

### 3.10.4 Read

The Read feature allows the user to read the entire Serial EEPROM memory array, a specific word address or a range of word addresses. When the **Read** button is pressed, a pop-up window appears, allowing the user to enter details related to the read operation to be performed.

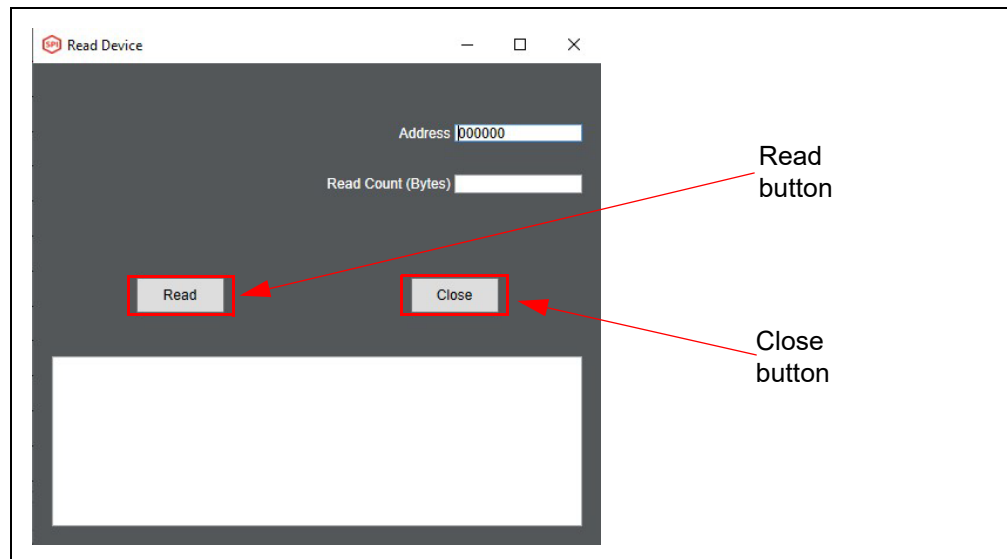
**Note:** The Read feature will not update the GUI memory array or GUI Security register. To update the internal GUI buffer, use the Refresh feature by pressing the **Refresh** button (see the [Section 3.10.1 “REFRESH”](#) for additional information).

The user can input a starting word address using the Memory Address field that the read operation will start at (in hexadecimal) and the Read Count or the amount of bytes to be read. Once all the input data has been filled, press the **Read** button to start the read operation.

**Note:** The user may be able to change the starting address, but the GUI will limit the word address to the boundary of that region.

Once the read operation is complete, the data read from the device will be displayed in the box below the **Read** and **Close** buttons. The user can perform as many read operations as preferred from this window. For each new read operation, the data field will be re-written using the data read from the current read operation being performed. Once all read operations are completed, the user can close the window by pressing the **Close** button.

**FIGURE 3-14: READ OPERATION**

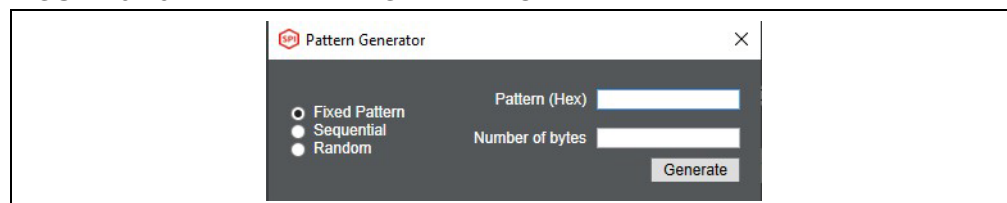


### 3.10.5 Write

The Write feature allows the user to write the entire Serial EEPROM memory array, a specific word address or a range of word addresses. When the **Write** button is pressed, a pop-up window appears, allowing the user to enter details related to the write operation to be performed.

The user inputs the data that is to be written in the “Data To Write” field (in hexadecimal) or the user can fill the “Data To Write” field with a generated pattern by pressing the **Generate Pattern** button as shown in [Figure 3-15](#).

**FIGURE 3-15: PATTERN GENERATION**



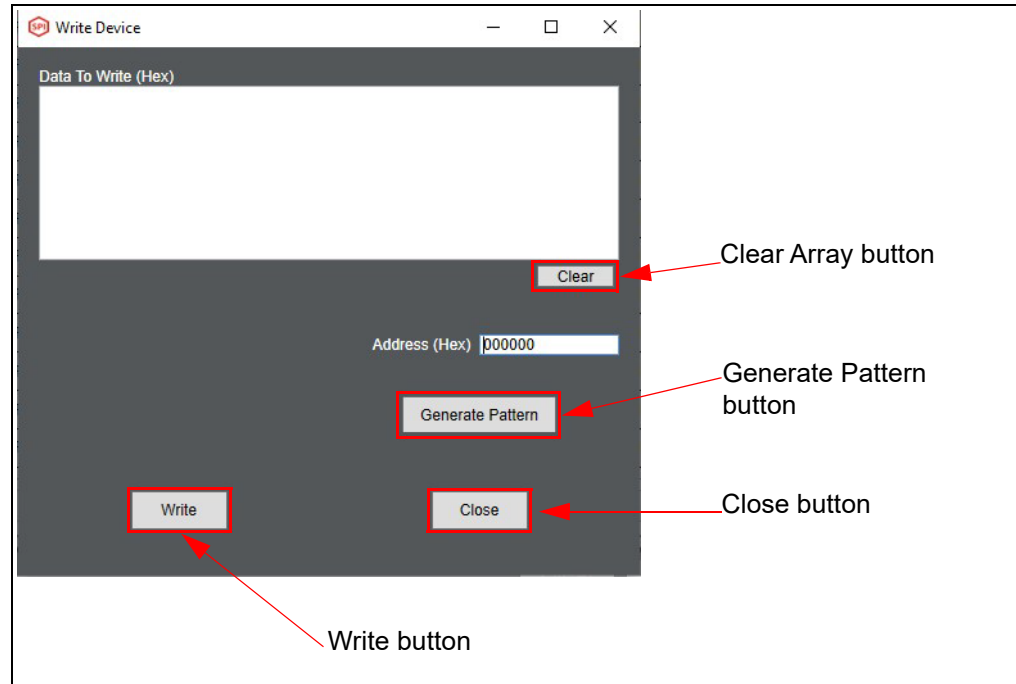
Once data has been input, the user then selects the starting word address using the “Address (Hex)” field that the write operation will start at (in hexadecimal).

The GUI limits write operations to the physical device boundary of that region. The write operation will be aborted if the address boundary of that particular memory region is exceeded. Once all the input data has been input, press the **Write** button to start the write operation. A status message will appear to notify the user that the write operation is complete.

**Note:** Due to the construction of the Serial EEPROM devices, the write operation is limited to the page size or boundary of the installed device. If the “Data” field exceeds the page boundary of the installed device, the GUI will automatically parse the data into the correct page size and perform multiple write operations until the entire “Data” field has been written to the Serial EEPROM.

Once the write operation is complete, the user can close the window by pressing the **Close** button or continue with another write operation. Once the **Close** button is pressed, a progress bar for the Refresh feature is displayed and the entire GUI memory array and Security register are read and the GUI buffer is updated with the new data.

**FIGURE 3-16: WRITE OPERATION**



### 3.10.6 Save

The **Save** button gives the user the ability to save the current state of the internal GUI buffer. The GUI memory array can be saved as either a Intel Hex (.hex), Plain Text (.txt) or Binary (.bin) file based on the user preference. Once a file type is selected, a file explorer will pop up, prompting the user to specify the file directory and name of the file.

**Note:** When using the Save feature, the software will create the data for the saved file based on the internal GUI buffer and not on the actual data from the Serial EEPROM.

### 3.10.7 Load

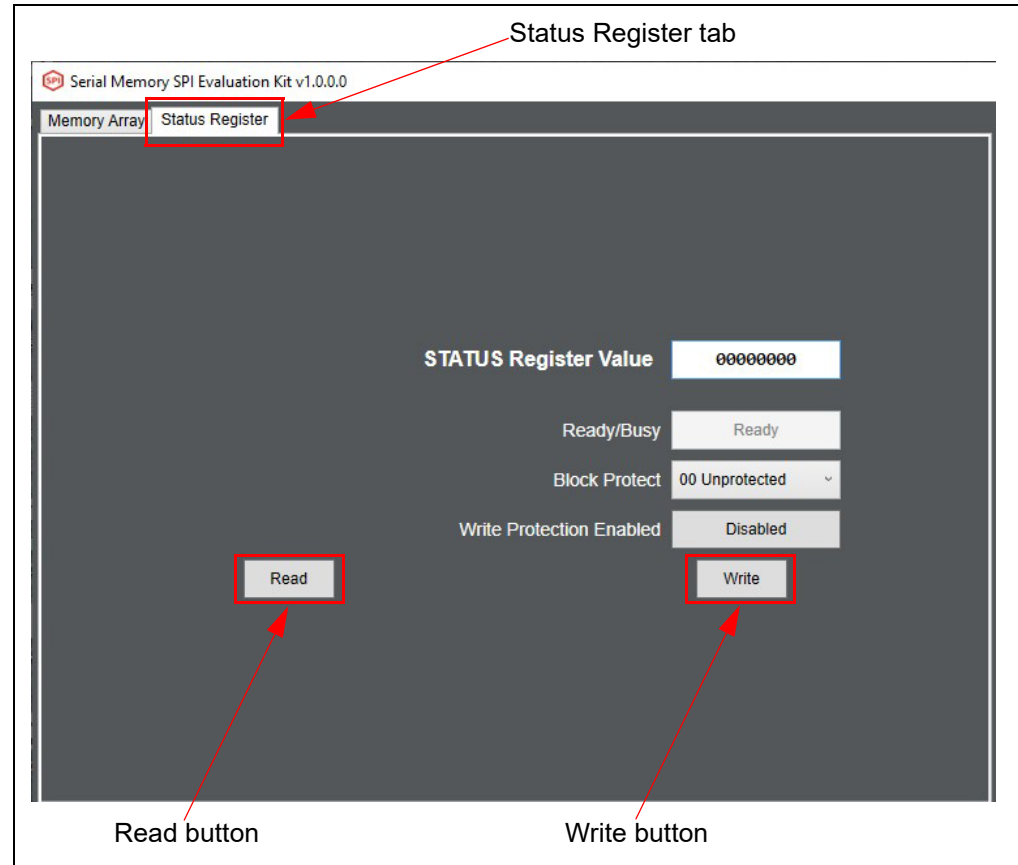
The **Load** button gives the user the option to load a previously saved GUI memory array (either Intel Hex (.hex) or Plain Text (.txt) file). The file, once loaded, will be used to populate the internal GUI buffer. Once the file is loaded in the GUI array buffer, the user must program the installed device using the **Program** button in order to write the data to the installed device (see [Section 3.10.3 "Program"](#) for additional information).

**Note:** The loaded file must follow a specific format. In order to determine the correct file format, it is recommended to save a GUI memory array as a reference (see [Section 3.10.6 "Save"](#) for additional information) and refer to that file when formatting the data.

## 3.11 STATUS REGISTER

The Status Register tab gives the user access to the STATUS register for the connected Serial EEPROM. The tab gives a breakdown of each writable bit or latch value.

**FIGURE 3-17: STATUS REGISTER**



### 3.11.1 Read

The Read feature allows the user to read the current contents of the STATUS register. A read will update the value shown (as binary) and will also update the decoded bits and latches.

### 3.11.2 Write

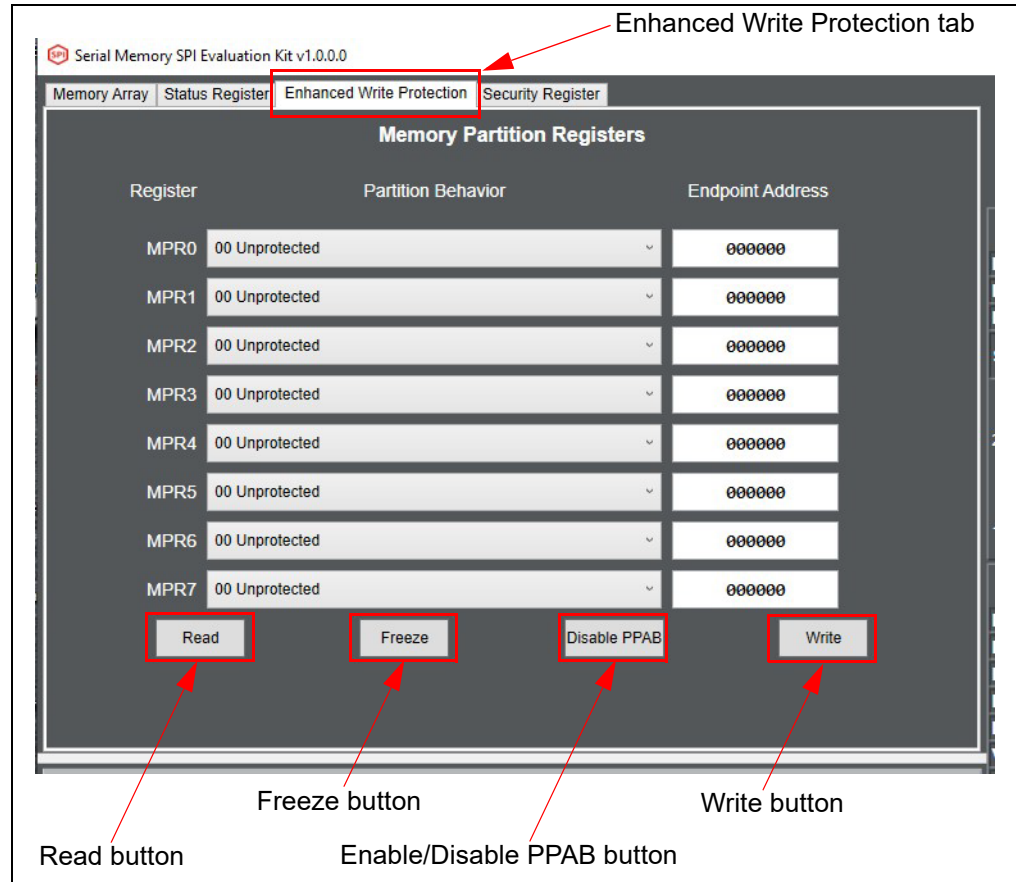
The Write feature allows the user to write the new STATUS register values to the installed device.

## 3.12 ENHANCED WRITE PROTECTION

The Enhanced Write Protection tab gives the user access to the various Memory Partition Registers (MPRs) for the connected Serial EEPROM. The tab allows the user to select each partition behavior and end point address.

**Note:** The Enhanced Write Protection tab will only be shown if the Memory Partition Registers feature is supported on the installed device.

**FIGURE 3-18: ENHANCED WRITE PROTECTION**



### 3.12.1 Read

The Read feature allows the user to read the current contents of each MPR. A read will update the values shown.

### 3.12.2 Freeze

The Freeze feature allows the user to freeze the current contents of the MPRs.

**Note:** This is a permanent operation and once completed, it cannot be undone.

### 3.12.3 Enable/Disable PPAB

The Enable PPAB feature allows the user to protect (Enable) or unprotect (Disable) the Partition Endpoint Addresses as currently specified in the Endpoint Addresses. Enabling PPAB protects the Endpoint Addresses from being unintentionally altered.

### 3.12.4 Write

The Write feature allows the user to write the new MPR values to the installed device.

## 3.13 SECURITY REGISTER

The Security register consists of two regions (size based on the selected supported device) with a factory-programmed unique serial number in the lower 16 bytes (address 00h to 0Fh) in the first section and a user-programmable lockable identification page in the second section.

**Note:** The Security Register tab will only be shown if the feature is supported on the installed device.

**FIGURE 3-19: SECURITY REGISTER**

Hexadecimal	00	01	02	03	04	05	06	07
000000	8A	25	85	19	24	10	04	00
000008	78	33	A8	88	A8	88	00	E2
000010	FF	FF	FF	FF	FF	FF	FF	FF
000018	FF	FF	FF	FF	FF	FF	FF	FF
000020	FF	FF	FF	FF	FF	FF	FF	FF
000028	FF	FF	FF	FF	FF	FF	FF	FF
000030	FF	FF	FF	FF	FF	FF	FF	FF
000038	FF	FF	FF	FF	FF	FF	FF	FF
000040	FF	FF	FF	FF	FF	FF	FF	FF
000048	FF	FF	FF	FF	FF	FF	FF	FF
000050	FF	FF	FF	FF	FF	FF	FF	FF
000058	FF	FF	FF	FF	FF	FF	FF	FF
000060	FF	FF	FF	FF	FF	FF	FF	FF
000068	FF	FF	FF	FF	FF	FF	FF	FF
000070	FF	FF	FF	FF	FF	FF	FF	FF
000078	FF	FF	FF	FF	FF	FF	FF	FF
000080	FF	FF	FF	FF	FF	FF	FF	FF
000088	FF	FF	FF	FF	FF	FF	FF	FF
000090	FF	FF	FF	FF	FF	FF	FF	FF
000098	FF	FF	FF	FF	FF	FF	FF	FF
0000A0	FF	FF	FF	FF	FF	FF	FF	FF
0000A8	FF	FF	FF	FF	FF	FF	FF	FF

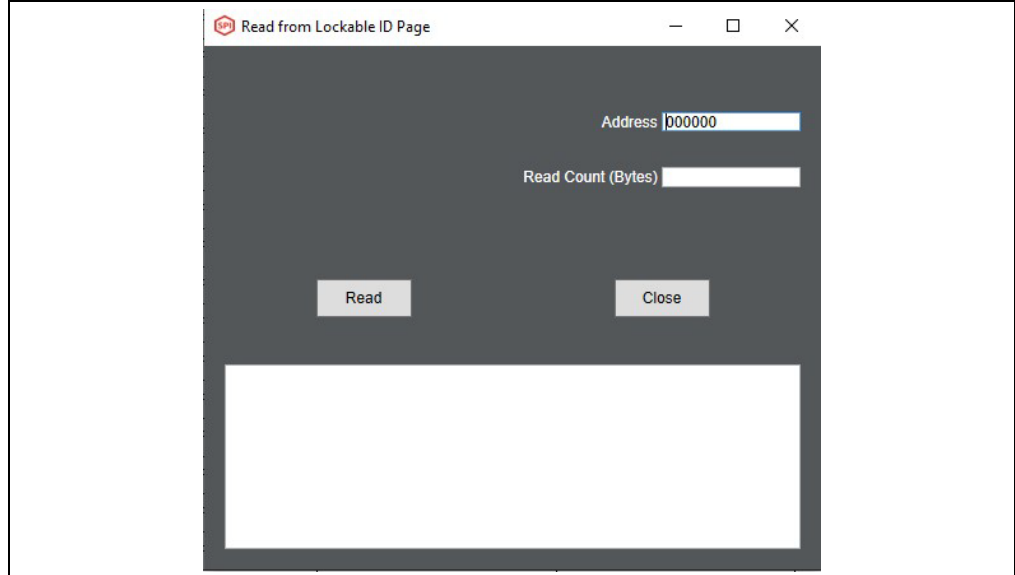
### 3.13.1 Refresh

The Refresh feature allows the user to read the entire current Security register contents from the installed device. The data shown in the current memory array will be overwritten with the data read from the device.

### 3.13.2 Read

The Read feature allows the user to specify the starting *Address* (in hexadecimal) and number of bytes (*Read Count*) read from the Security register by pressing the **Read** button.

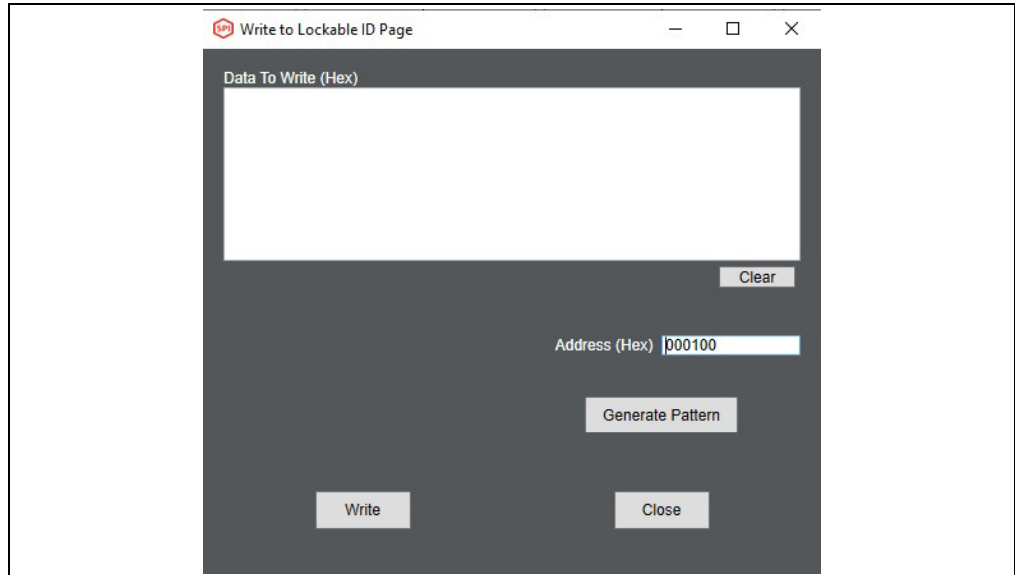
**FIGURE 3-20:**      **FIGURE 3-18: READ SECURITY REGISTER**



### 3.13.3 Write

The Write feature allows the user to write data to the lockable ID page. The default Address is byte0 of the lockable ID page, but can be changed by the user.

**FIGURE 3-21:**      **WRITE SECURITY REGISTER**



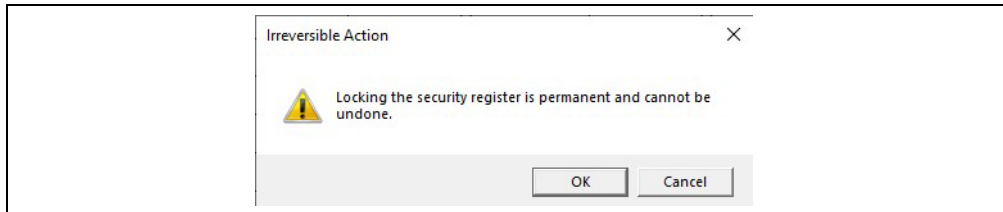
### 3.13.4 Lock

The Lock feature allows the user to lock the upper page of the Security register. This is accomplished by pressing the **Lock** button. A pop up will appear making the user confirm that this operation should be performed.

**Note:** This is a permanent operation and once completed, it cannot be undone.



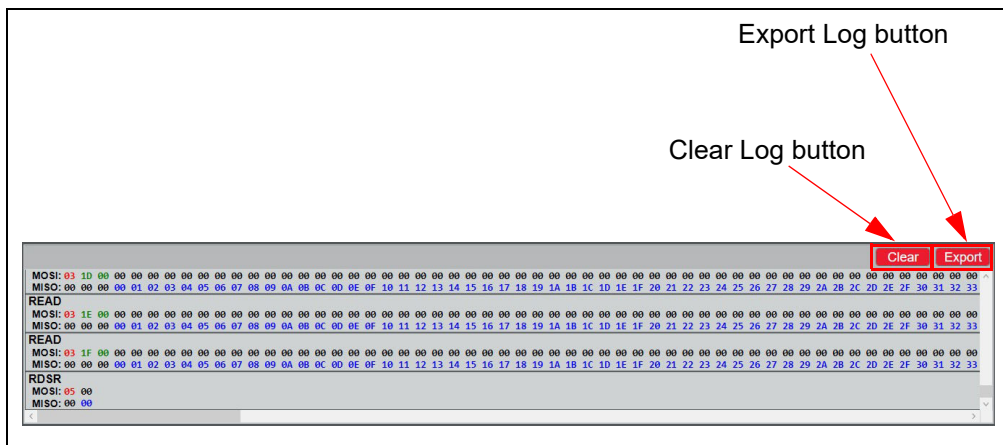
**FIGURE 3-22: LOCK SECURITY REGISTER**



### 3.14 TRANSACTION LOG

The Transaction Log records all SPI communication with the installed device as well as highlights the communication protocol according to the legend. The Transaction Log reports the data on the SPI bus in hexadecimal.

**FIGURE 3-23: TRANSACTION LOG**



#### 3.14.1 Clear Log

The **Clear** button clears the Transaction Log. The Clear Log function is helpful when the user wants to look at a specific type(s) or group(s) of SPI protocol.

#### 3.14.2 Export Log

The **Export** button exports the Transaction Log in HTML format. The exported Transaction Log can be used as a reference without having to resend protocol to the installed device.

---

---

## Chapter 4. USB Base Board Firmware Update

---

---

### 4.1 INTRODUCTION

The Microchip Technology Serial Memory Evaluation kit has a built-in ability to update the USB Base Board using a sequence of steps outlined by GUI or using the Atmel FLeXible In-system Programming (FLIP) software.

**Note:** Both USB Base Board firmware update modes use Atmel FLIP software and, therefore, it must be installed on the user's PC in order to perform either firmware update process.

### 4.2 USING THE GUI TO UPDATE THE FIRMWARE

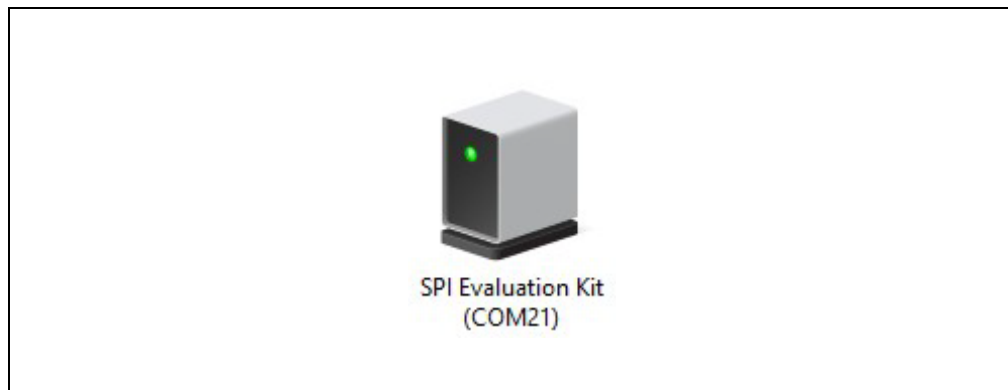
If the GUI detects the firmware needs to be updated, it will prompt the user to update the firmware using a sequence of steps outlined on the screen. Please follow the steps on the screen and the firmware will be updated. Note that once the USB Base Board firmware has been updated, it is recommended that the customer disconnect the USB Base Board from the PC and reconnect (as specified by the GUI) before restarting the GUI.

**Note:** The USB Base Board must be reset or disconnected after the firmware update in order to complete the process.

### 4.3 USING THE FLIP SOFTWARE TO UPDATE THE FIRMWARE

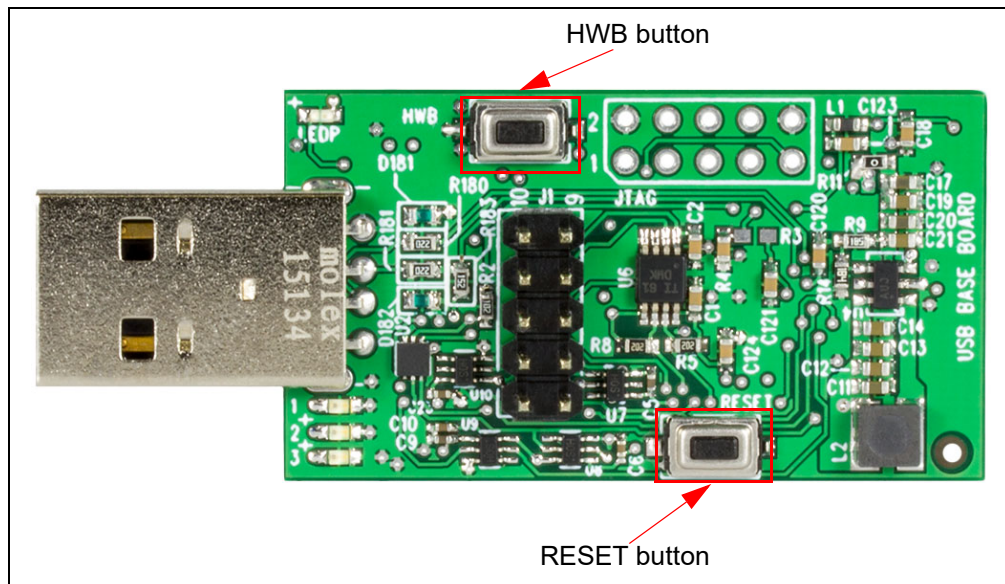
If the user chooses to update the firmware using the more manual FLIP software process, first plug in the USB Base Board into a USB port without the SPI Socket Board connected. The PC will recognize the USB Base Board as "SPI Evaluation Kit" in the PC's Devices and Printers window from the Control Panel, if there is firmware already loaded in the USB Base Board (Figure 4-1). Note that the COM port numeration may change based on the user's PC.

**FIGURE 4-1: SPI EVALUATION KIT COM PORT**



Once the USB Base Board is plugged in and recognized by the PC, the user should enable DFU mode on the USB Base Board. DFU mode is enabled by a specific sequence of **HWB** and **RESET** buttons. Refer to Figure 4-2 for locations of the **HWB** and **RESET** buttons.

**FIGURE 4-2: USB BASE BOARD BUTTONS**



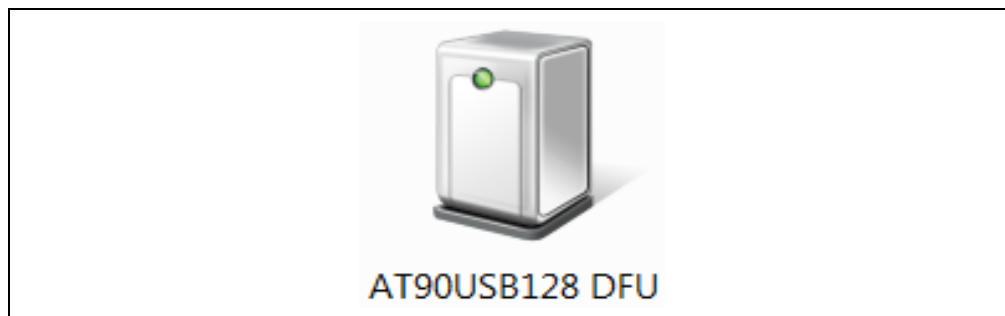
Once the **HWB** and **RESET** buttons have been located, use the specific press and hold sequence shown below to enable DFU mode on the USB Base Board:

- Press and hold the **HWB** button
- Press and release the **RESET** button
- Release the **HWB** button

**Note:** Once DFU mode is enabled on the USB Base Board, the rest of the firmware update process must be completed in order to ensure robust USB Base Board operation.

Once the USB Base Board has DFU mode enabled, allow the PC to relearn the USB Base Board as “AT90USB128 DFU” (Figure 4-3). If the PC does not automatically recognize the USB Base Board as stated above and shown below, it is recommended to unplug the USB Base Board from the PC and restart the procedure.

**FIGURE 4-3: AT90USB128 DFU COM PORT**

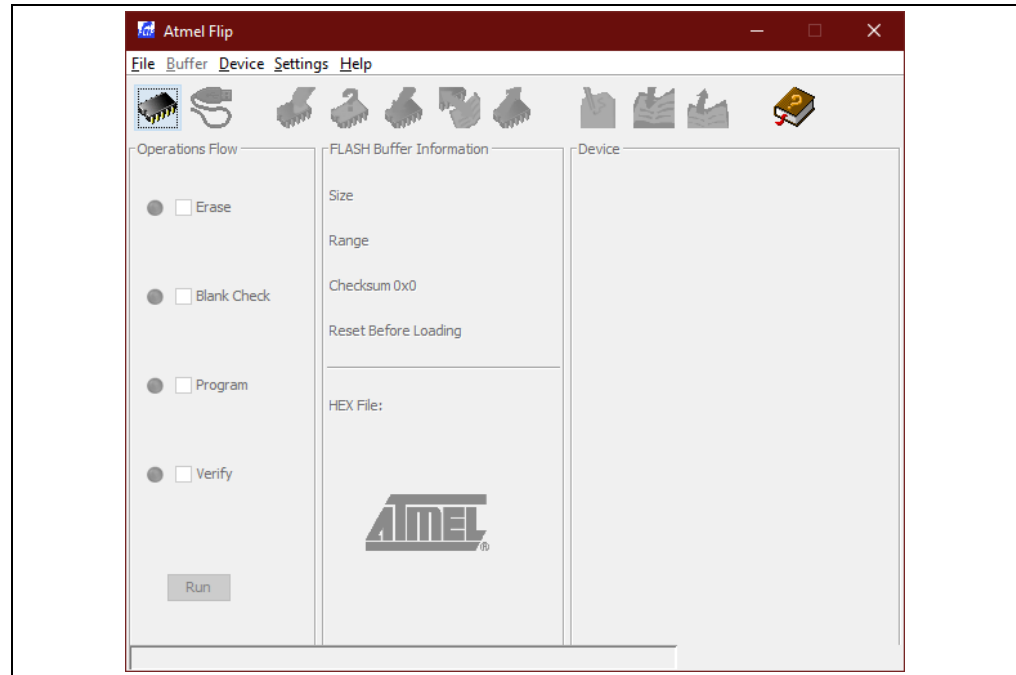


## 4.4 FLIP SOFTWARE UTILITY

Once the USB Base Board has DFU mode enabled and the COM port is released by the PC, perform the following sequence using the FLIP Software Utility to update the USB Base Board firmware:

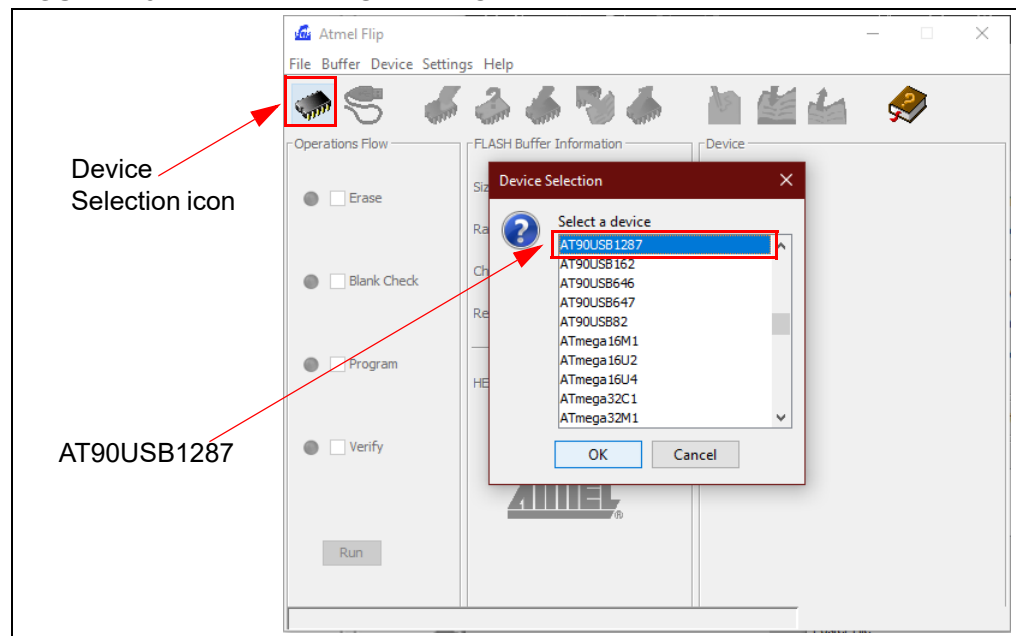
1. Open the FLIP Software Utility (Figure 4-4) by either selecting the desktop icon (if created) or selecting “Flip 3.4.7” (3.4.7 indicates the version) from the Start Menu folder.

FIGURE 4-4: FLIP SOFTWARE UTILITY



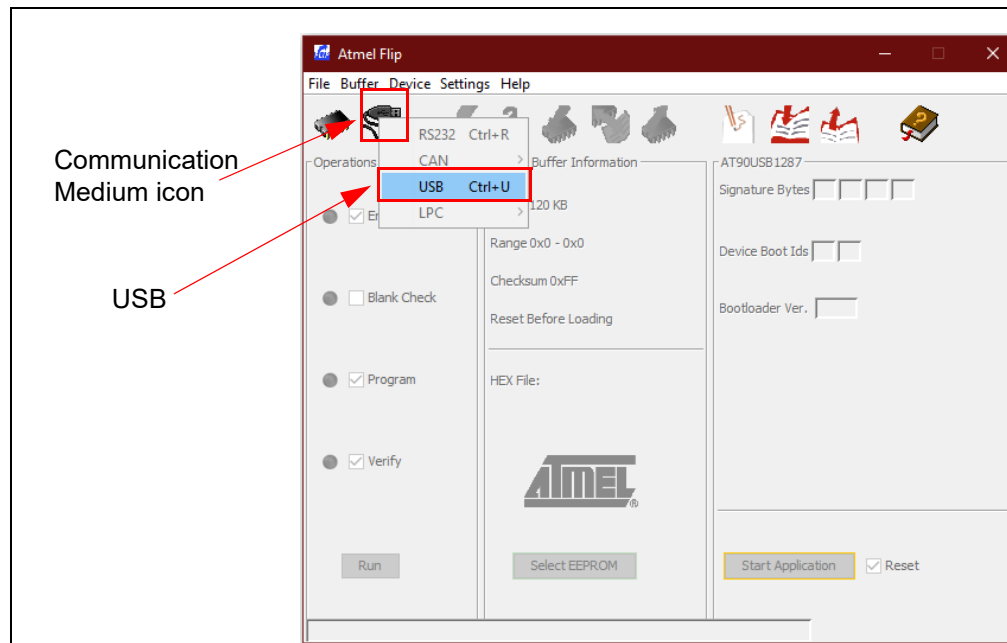
2. After opening the FLIP Software Utility, navigate to the Device Selection icon as shown below. Select the “AT90USB1287” as the device and press the **OK** button.

FIGURE 4-5: DEVICE SELECTION



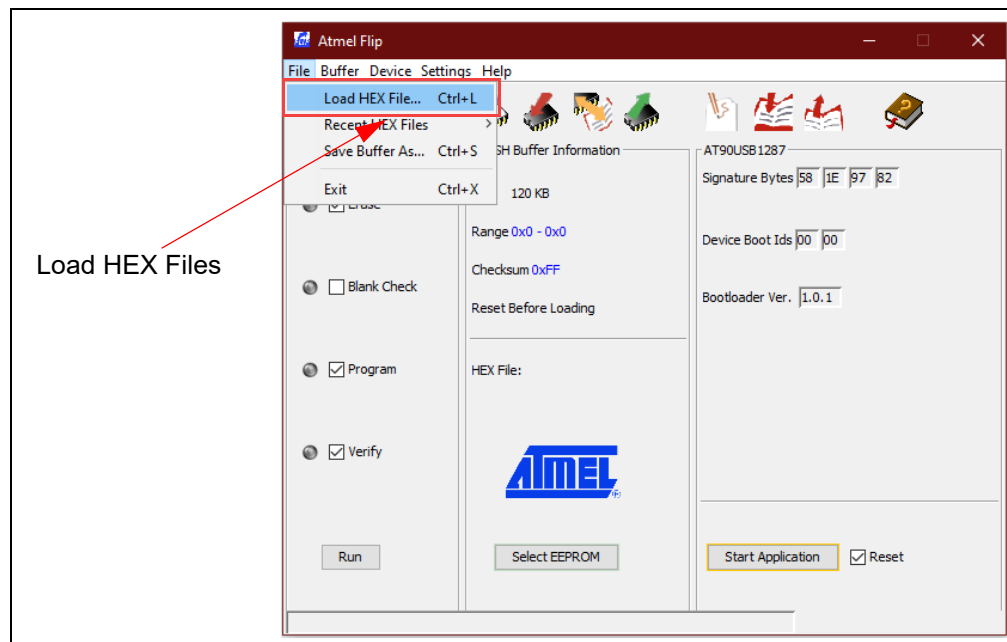
- Once the target device has been selected, click on the Communication Medium icon as shown below and select "USB". Once "USB" is selected, an additional dialog box is displayed. Press the **Open** button to continue.

**FIGURE 4-6: COMMUNICATION MEDIUM SELECTION**



- Once the communication between the PC and the AT90USB1287 (USB Base Board microcontroller) has been established, navigate to File and select "Load HEX Files" as shown in Figure 4-7.

**FIGURE 4-7: LOAD FILE**



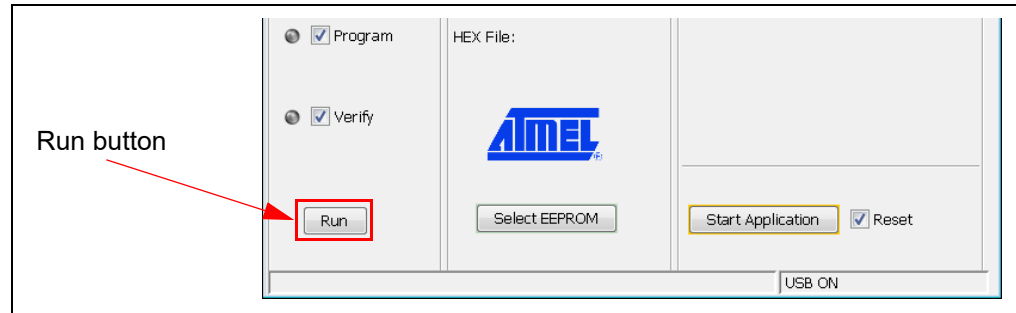
# EV20F92A Serial Memory SPI Evaluation Kit User's Guide

- Proceed to load the SPI firmware by navigating to the firmware found at:  
C:\Program Files (x86)\Microchip\Serial Memory Evaluation Kits\SPI\Firmware

**Note:** If the default installation was not used when the EV20F92A SPI GUI was installed, it is the user's responsibility to determine the SPI firmware file location.

- Once the HEX file has been loaded into the FLIP Software Utility, press the **Run** button to program the new firmware to the AT90USB1287 as shown in [Figure 4-8](#). A progress or status bar is included to show the overall progress of the hex image program.

**FIGURE 4-8: RUN FLIP SOFTWARE**

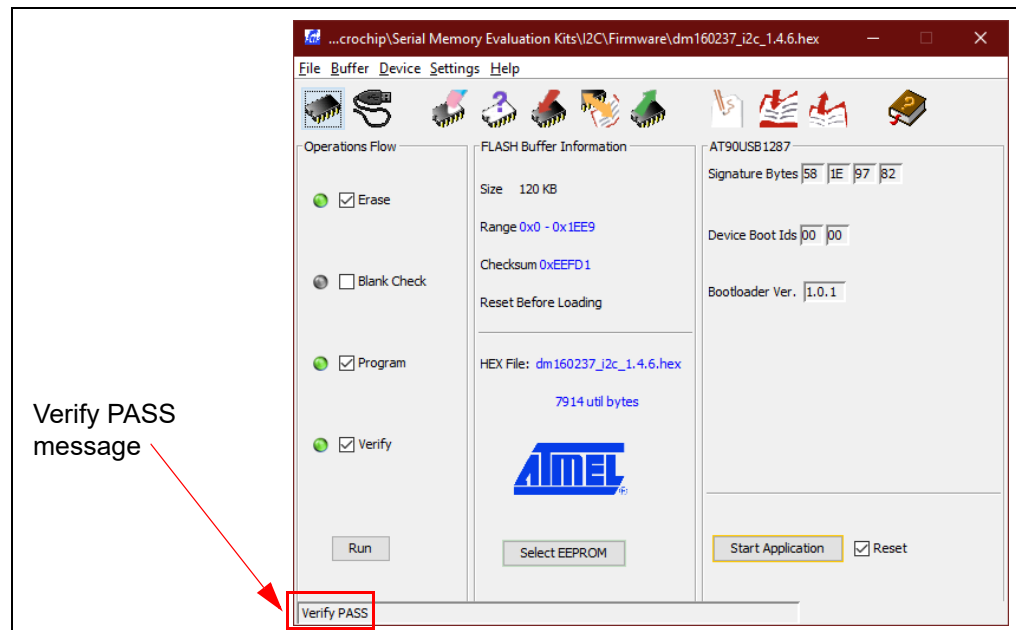


- If the "Verified Pass" is reported in the FLIP Software Utility (see [Figure 4-9](#)), close the FLIP Software Utility and remove the USB Base Board from the PC. The USB Base Board Firmware Update procedure is complete.

**Note:** If the USB Base Board was updated successfully, the PC will recognize the USB Base Board as "SPI Evaluation Kit" (see [Figure 4-1](#)).

If the "Verified Pass" is not shown, or any other error is displayed, it is recommended to unplug the USB Base Board from the PC and restart the entire firmware update procedure.

**FIGURE 4-9: FLIP SOFTWARE COMPLETE**



---

---

## Chapter 5. Troubleshooting Guide

---

---

**ISSUE:**

**USB BASE BOARD IS NOT RECOGNIZED BY THE USER'S PC**

**SOLUTION:**

The USB Base Board driver is not installed or not installed properly. Download and install the USB Base Board driver using the procedure outlined in [Section 2.2 “Installing the Graphical User Interface \(GUI\)”](#).

The USB Base Board firmware was not programmed properly or has become corrupted. Perform the USB Base Board Firmware Update procedure outlined in [Chapter 4. “USB Base Board Firmware Update”](#).

If the problem persists, contact your local Sales representative for additional support or create a support ticket at [www.microchip.com/support](http://www.microchip.com/support).

**ISSUE:**

**GUI STATES THE USER MUST PERFORM A FIRMWARE UPDATE TO THE USB BASE BOARD**

**SOLUTION:**

Perform the USB Base Board Firmware Update procedure outlined in [Chapter 4. “USB Base Board Firmware Update”](#).

If the problem persists, contact your local Sales representative for additional support or create a support ticket at [www.microchip.com/support](http://www.microchip.com/support).

**ISSUE:**

**GUI STATES THERE IS NO DEVICE INSTALLED IN THE SPI SOCKET BOARD**

**SOLUTION:**

Close the GUI and remove the USB Base Board from the PC. Verify that the SPI Socket Board and the USB Base Board are connected properly. Verify that the device is installed correctly in the SOIC socket on the SPI Socket Board and that the pin 1 indicators match. Refer to [Section 2.5 “Evaluation Kit Setup Procedure”](#) for additional information. Make sure the device is completely sitting in the socket. Plug the SPI Socket Board into the USB Base Board and restart the GUI.

If the problem persists, contact your local Sales representative for additional support or create a support ticket at [www.microchip.com/support](http://www.microchip.com/support).

---

---

## Appendix A. Schematics

---

---

### A.1 INTRODUCTION

This appendix contains the following schematics for the EV20F92A Serial Memory SPI Evaluation Kit:

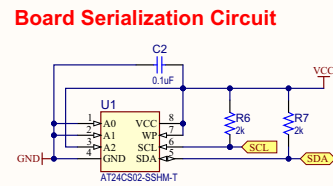
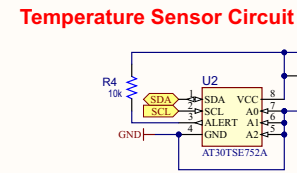
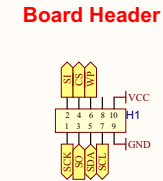
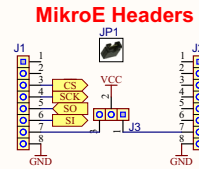
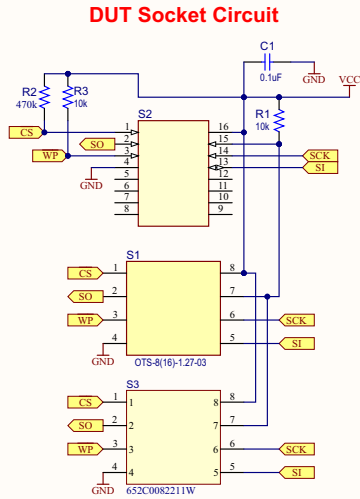
- SPI Socket Board (04-11160)
- USB Base Board (02-10682)

**Note:** Electronic versions of the SPI Socket Board and USB Base Board schematics can be downloaded from <http://www.microchip.com/EV20F92A> under "Documentation and Software".



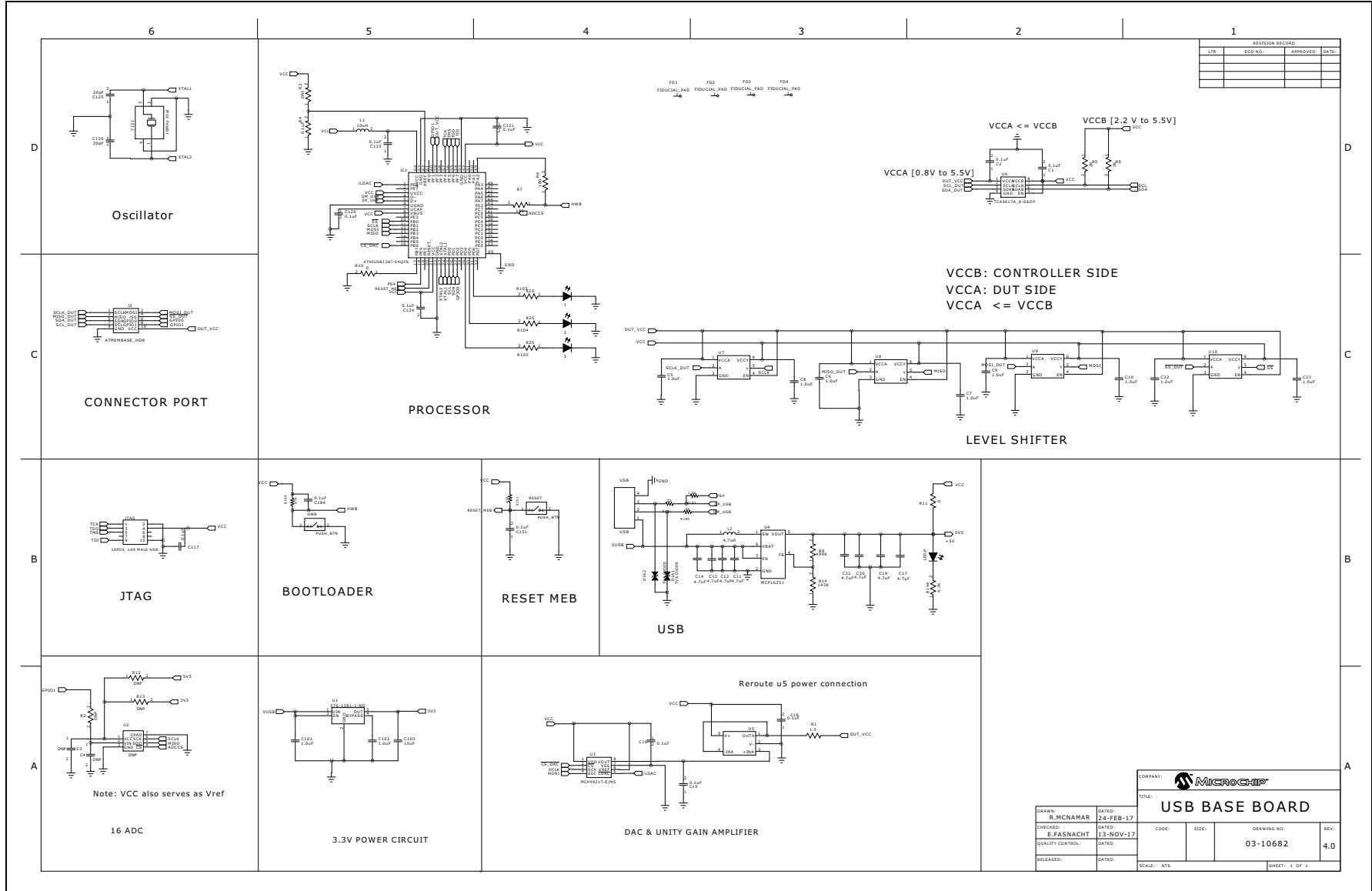
## A.2 SPI SOCKET BOARD (04-11160)

REV	ECO#	DESCRIPTION	DATE
3.0		Added MikroE Headers	12/07/2020



Drawn By: Erik Fasnacht		
Engineer: Erik Fasnacht		
PartNumber: EV90F92A	Project Title: <b>SPI Socket Board</b>	
Sheet Title: <b>11160 SPI Socket Board</b>		
Size: B	Sch #03-11160 Revision:3.0	Date: 9/17/2021 1:33:39 PM Sheet 1 of 1
File: 11160_R3.0.SchDoc		

### A.3 USB BASE BOARD (02-10682)



**Appendix B. Bill of Materials (BOM)**

**TABLE B-1: SPI SOCKET BOARD (04-11160)<sup>(1)</sup>**

Qty	Reference	Description	Manufacturer	Part Number
5	C1, C2, C3	Ceramic Capacitor, 0.1 $\mu$ F, 10V, 10% X7R SMD 0603	Kemet	C0603C104K8RACTU
1	H1	Receptacle Connector, 100", 10 positions Dual Gold	Samtec Inc.	SSW-105-01-F-D
2	J1, J2	Connector Header Through Hole 8 position 0.100" (2.54 mm)	Würth Elektronik	61300811121
1	J3	Connector Header Through Hole 3 position 0.100" (2.54 mm)	Molex	0901200123
1	JP1	MECH HW JUMPER 2.54mm 1x2	Sullins Connector Solutions	SSC02SYAN
1	PCB	Printed Circuit Board – EV20F92A SPI Socket Board	Microchip Technology Inc.	<b>04-11160</b>
8	R1, R3, R4	Resistor SMD, 10 kOhms, 5%, 1/10W, 0603	Panasonic	ERJ-3GEYJ103V
11	R2	Resistor SMD, 470 kOhms, 5%, 1/10W, 0603	Panasonic	ERJ-3GEYJ474V
1	R6, R7	Resistor TKF, 2 kOhms, 1%, 1/10W, 0603	Panasonic	ERJ-3EKF2001V
1	S1	8-Lead SOIC Socket	Enplas	OTS-8(16)-1.27-03
1	U1	Atmel 2 Kb Serialized Two-Wire Device SOIC-8	Microchip Technology Inc.	<b>AT24CS02-SSHM-T</b>
1	U2	Atmel 2 Kb Digital Temperature Sensor SOIC-8	Microchip Technology Inc.	<b>AT30TSE752A-SS8M-T</b>

**Note 1:** The components listed in this Bill of Materials are representative of the PCB assembly. The released BOM used in manufacturing uses all RoHS-compliant components.

**TABLE B-2: USB BASE BOARD (02-10682)<sup>(1)</sup>**

Qty	Reference	Description	Manufacturer	Part Number
3	1, 2, 3	LED RED CLEAR 0603 SMD	Lite-On® Technology Corporation	LTST-C191KRKT
13	C1, C2, C15, C16, C18, C117, C120, C121, C123, C124, C151, C184, R4	Ceramic capacitor, 0.1 $\mu$ F, 50V Y5V 0603	Yageo Corporation	CC0603ZRY5V9BB104
10	C5, C6, C7, C8, C9, C10, C22, C23, C101, C102	Ceramic capacitor, 1 $\mu$ F, 6.3V X5R 0402	Taiyo Yuden Co., Ltd.	JMK105BJ105KV-F

**Note 1:** The components listed in this Bill of Materials are representative of the PCB assembly. The released BOM used in manufacturing uses all RoHS-compliant components.

# EV20F92A Serial Memory SPI Evaluation Kit User's Guide

**TABLE B-2: USB BASE BOARD (02-10682)<sup>(1)</sup> (CONTINUED)**

Qty	Reference	Description	Manufacturer	Part Number
8	C11, C12, C13, C14, C17, C19, C20, C21	Ceramic capacitor, 4.7 $\mu$ F, 10V X5R 0603	KEMET	C0603C475K8PACTU
1	C103	Ceramic capacitor, 10 $\mu$ F, 6.3V X5R 0603	Taiyo Yuden Co., Ltd.	JMK107BJ106MA-T
2	C125, C126	Ceramic capacitor, 20 pF, 250V C0G/NP0 0603	Johanson Technology, Inc.	251R14S200GV4T
2	D181, D182	TVS Diode, 24VWM 150VC 0603	Littelfuse <sup>®</sup> Inc.	PGB1010603MR
2	HWB, RESET	Tactile switch SPST-NO 0.05A 12V	Apem, Inc.	ADTSM31NV
1	IC2	IC 8-bit MCU, 128 KB, Flash 64QFN	Microchip Technology Inc.	<b>AT90USB1287-MU</b>
1	J1	Connector – Header, 100" Dual STR, 10 positions	Sullins Connector Solutions	PRPC005DAAN-RC
8	C3, C4, JTAG, R12, R13, R2, R3, U2	<b>DO NOT POPULATE</b>		
1	L1	Fixed inductor, 10 $\mu$ H, 50 mA, 900 MOHM SMD	Murata Electronics North America, Inc.	LQM18FN100M00D
1	L2	Fixed inductor, 4.7 $\mu$ H, 1.2A 105 MOHM	Würth Electronics Inc.	744031004
1	LEDP	LED Blue Diffused, 0603 SMD	Osram Opto Semiconductors GmbH	LB Q39G-L200-35-1
1	PCB	Printed Circuit Board – EV20F92A USB Base Board	Microchip Technology Inc.	<b>01-10682</b>
1	R1	Resistor SMD 1.5 Ohm, 5%, 1/10W 0603	Yageo Corporation	RC0603JR-071R5L
2	R5, R8	Resistor SMD 2K Ohm, 5%, 1/10W 0603	Yageo Corporation	RC0603JR-072KL
2	R6, R7	Resistor SMD 180 Ohm, 5%, 1/10W 0603	Yageo Corporation	RC0603JR-07180RL
1	R9	Resistor SMD 499K Ohm, 1%, 1/10W 0603	Yageo Corporation	RC0603FR-07499KL
2	R10, R11	Resistor SMD 0.0 Ohm Jumper, 1/10W 0603	Yageo Corporation	RC0603JR-070RL
1	R14	Resistor SMD 143K Ohm, 1%, 1/10W 0603	Yageo Corporation	RC0603FR-07143KL
3	R103, R104, R105	Resistor SMD 825 Ohm, 1%, 1/10W 0603	Yageo Corporation	RC0603FR-07825RL
1	R144	Resistor SMD 4.7K Ohm, 5%, 1/10W 0603	Yageo Corporation	RC0603JR-074K7L
2	R151, R184	Resistor SMD 47K Ohm, 1%, 1/10W 0603	Yageo Corporation	RC0603FR-0747KL
2	R180, R181	Resistor SMD 22 Ohm, 5%, 1/10W 0603	Yageo Corporation	RC0603JR-0722RL
1	R183	Resistor SMD 1.5K Ohm, 5%, 1/10W 0603	Yageo Corporation	RC0603JR-071K5L
1	U1	Linear Regulator IC 3.3V, 0.5A, SOT23-5	Microchip Technology Inc.	<b>MIC5219-3.3YM5-TR</b>

**Note 1:** The components listed in this Bill of Materials are representative of the PCB assembly. The released BOM used in manufacturing uses all RoHS-compliant components.

# EV20F92A Serial Memory SPI Evaluation Kit User's Guide

**TABLE B-2: USB BASE BOARD (02-10682)<sup>(1)</sup> (CONTINUED)**

Qty	Reference	Description	Manufacturer	Part Number
1	U3	IC DAC 12BIT SNGL W/SPI 8-MSOP	Microchip Technology Inc.	<b>MCP4921T-E/MS</b>
1	U4	Boost regulator adjustable IC 0.65A SYNC SOT23	Microchip Technology Inc.	<b>MCP16251T-I/CH</b>
1	U5	IC OPAMP GP 3 MHz RRO SOT23-5	Analog Devices, Inc.	AD8531ARTZ-REEL7
1	U6	IC V-Level XLATR FM+ I2C 8-VSSOP	Texas Instruments	TCA9617ADGKR
4	U7, U8, U9, U10	Translator bidirectional SGL LL SC70-6	Analog Devices Inc.	ADG3301BKSZ-REEL7
1	USB	Plug connector USB, 4 positions, right angle PCB	Molex <sup>®</sup> LLC	0480370001
1	Y121	Crystal 16.0000 MHz, 18 pF SMD	Abracon <sup>®</sup> LLC	ABM3B-16.000MHZ-B2-T

**Note 1:** The components listed in this Bill of Materials are representative of the PCB assembly. The released BOM used in manufacturing uses all RoHS-compliant components.



# MICROCHIP

## Worldwide Sales and Service

### AMERICAS

**Corporate Office**  
2355 West Chandler Blvd.  
Chandler, AZ 85224-6199  
Tel: 480-792-7200  
Fax: 480-792-7277  
Technical Support:  
<http://www.microchip.com/support>  
Web Address:  
[www.microchip.com](http://www.microchip.com)

**Atlanta**  
Duluth, GA  
Tel: 678-957-9614  
Fax: 678-957-1455

**Austin, TX**  
Tel: 512-257-3370

**Boston**  
Westborough, MA  
Tel: 774-760-0087  
Fax: 774-760-0088

**Chicago**  
Itasca, IL  
Tel: 630-285-0071  
Fax: 630-285-0075

**Dallas**  
Addison, TX  
Tel: 972-818-7423  
Fax: 972-818-2924

**Detroit**  
Novi, MI  
Tel: 248-848-4000

**Houston, TX**  
Tel: 281-894-5983

**Indianapolis**  
Noblesville, IN  
Tel: 317-773-8323  
Fax: 317-773-5453  
Tel: 317-536-2380

**Los Angeles**  
Mission Viejo, CA  
Tel: 949-462-9523  
Fax: 949-462-9608  
Tel: 951-273-7800

**Raleigh, NC**  
Tel: 919-844-7510

**New York, NY**  
Tel: 631-435-6000

**San Jose, CA**  
Tel: 408-735-9110  
Tel: 408-436-4270

**Canada - Toronto**  
Tel: 905-695-1980  
Fax: 905-695-2078

### ASIA/PACIFIC

**Australia - Sydney**  
Tel: 61-2-9868-6733

**China - Beijing**  
Tel: 86-10-8569-7000

**China - Chengdu**  
Tel: 86-28-8665-5511

**China - Chongqing**  
Tel: 86-23-8980-9588

**China - Dongguan**  
Tel: 86-769-8702-9880

**China - Guangzhou**  
Tel: 86-20-8755-8029

**China - Hangzhou**  
Tel: 86-571-8792-8115

**China - Hong Kong SAR**  
Tel: 852-2943-5100

**China - Nanjing**  
Tel: 86-25-8473-2460

**China - Qingdao**  
Tel: 86-532-8502-7355

**China - Shanghai**  
Tel: 86-21-3326-8000

**China - Shenyang**  
Tel: 86-24-2334-2829

**China - Shenzhen**  
Tel: 86-755-8864-2200

**China - Suzhou**  
Tel: 86-186-6233-1526

**China - Wuhan**  
Tel: 86-27-5980-5300

**China - Xian**  
Tel: 86-29-8833-7252

**China - Xiamen**  
Tel: 86-592-2388138

**China - Zhuhai**  
Tel: 86-756-3210040

### ASIA/PACIFIC

**India - Bangalore**  
Tel: 91-80-3090-4444

**India - New Delhi**  
Tel: 91-11-4160-8631

**India - Pune**  
Tel: 91-20-4121-0141

**Japan - Osaka**  
Tel: 81-6-6152-7160

**Japan - Tokyo**  
Tel: 81-3-6880-3770

**Korea - Daegu**  
Tel: 82-53-744-4301

**Korea - Seoul**  
Tel: 82-2-554-7200

**Malaysia - Kuala Lumpur**  
Tel: 60-3-7651-7906

**Malaysia - Penang**  
Tel: 60-4-227-8870

**Philippines - Manila**  
Tel: 63-2-634-9065

**Singapore**  
Tel: 65-6334-8870

**Taiwan - Hsin Chu**  
Tel: 886-3-577-8366

**Taiwan - Kaohsiung**  
Tel: 886-7-213-7830

**Taiwan - Taipei**  
Tel: 886-2-2508-8600

**Thailand - Bangkok**  
Tel: 66-2-694-1351

**Vietnam - Ho Chi Minh**  
Tel: 84-28-5448-2100

### EUROPE

**Austria - Wels**  
Tel: 43-7242-2244-39  
Fax: 43-7242-2244-393

**Denmark - Copenhagen**  
Tel: 45-4485-5910  
Fax: 45-4485-2829

**Finland - Espoo**  
Tel: 358-9-4520-820

**France - Paris**  
Tel: 33-1-69-53-63-20  
Fax: 33-1-69-30-90-79

**Germany - Garching**  
Tel: 49-8931-9700

**Germany - Haan**  
Tel: 49-2129-3766400

**Germany - Heilbronn**  
Tel: 49-7131-72400

**Germany - Karlsruhe**  
Tel: 49-721-625370

**Germany - Munich**  
Tel: 49-89-627-144-0  
Fax: 49-89-627-144-44

**Germany - Rosenheim**  
Tel: 49-8031-354-560

**Israel - Ra'anana**  
Tel: 972-9-744-7705

**Italy - Milan**  
Tel: 39-0331-742611  
Fax: 39-0331-466781

**Italy - Padova**  
Tel: 39-049-7625286

**Netherlands - Drunen**  
Tel: 31-416-690399  
Fax: 31-416-690340

**Norway - Trondheim**  
Tel: 47-7288-4388

**Poland - Warsaw**  
Tel: 48-22-3325737

**Romania - Bucharest**  
Tel: 40-21-407-87-50

**Spain - Madrid**  
Tel: 34-91-708-08-90  
Fax: 34-91-708-08-91

**Sweden - Gothenberg**  
Tel: 46-31-704-60-40

**Sweden - Stockholm**  
Tel: 46-8-5090-4654

**UK - Wokingham**  
Tel: 44-118-921-5800  
Fax: 44-118-921-5820