

THIS DRAWING IS UNPUBLISHED. RELEASED FOR PUBLICATION
 © COPYRIGHT - TE Connectivity Ltd. ALL RIGHTS RESERVED.

REVISIONS				
P	LTR	DESCRIPTION	DATE	APVD
H2		REVISED PER ECR-18-018655	11DEC2018	BW SV

- 1 CONTINUOUS STRIP ON REELS WITH TERMINALS LOCATED ON 8.38±0.08 [.330±.003] CENTERS
- 2 SLOT ACCEPTS 0.25-0.32mm [#30-#28]AWG COPPER MAGNET WIRE. TWO WIRES OF THE SAME SIZE MAX PER SLOT
- 3 IDENTIFICATION NUMBER 6 FOR THE MAGNET WIRE SLOT SIZE
- 4 0.25 [.010] MAX CARRIER CUT-OFF TABS.

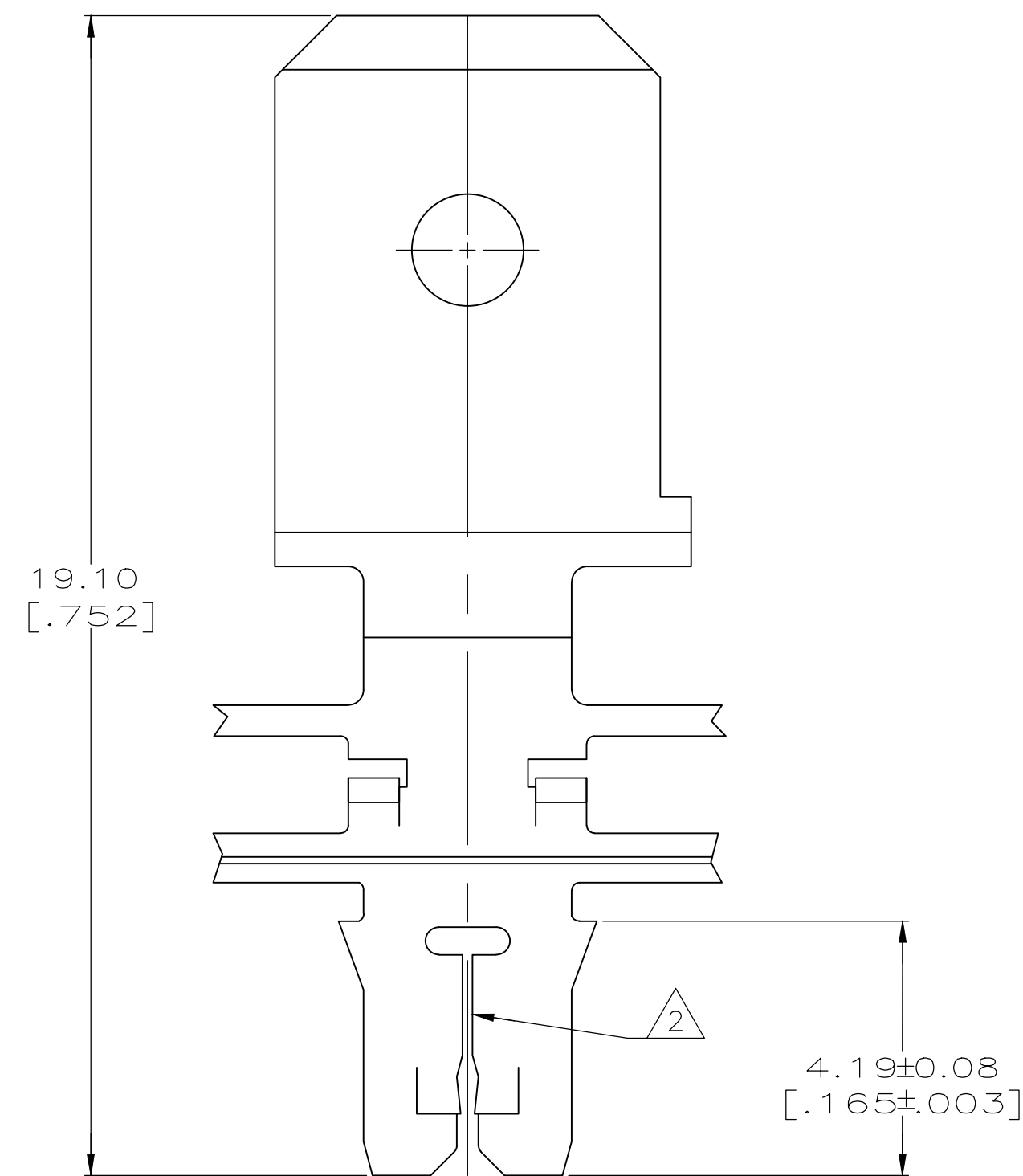
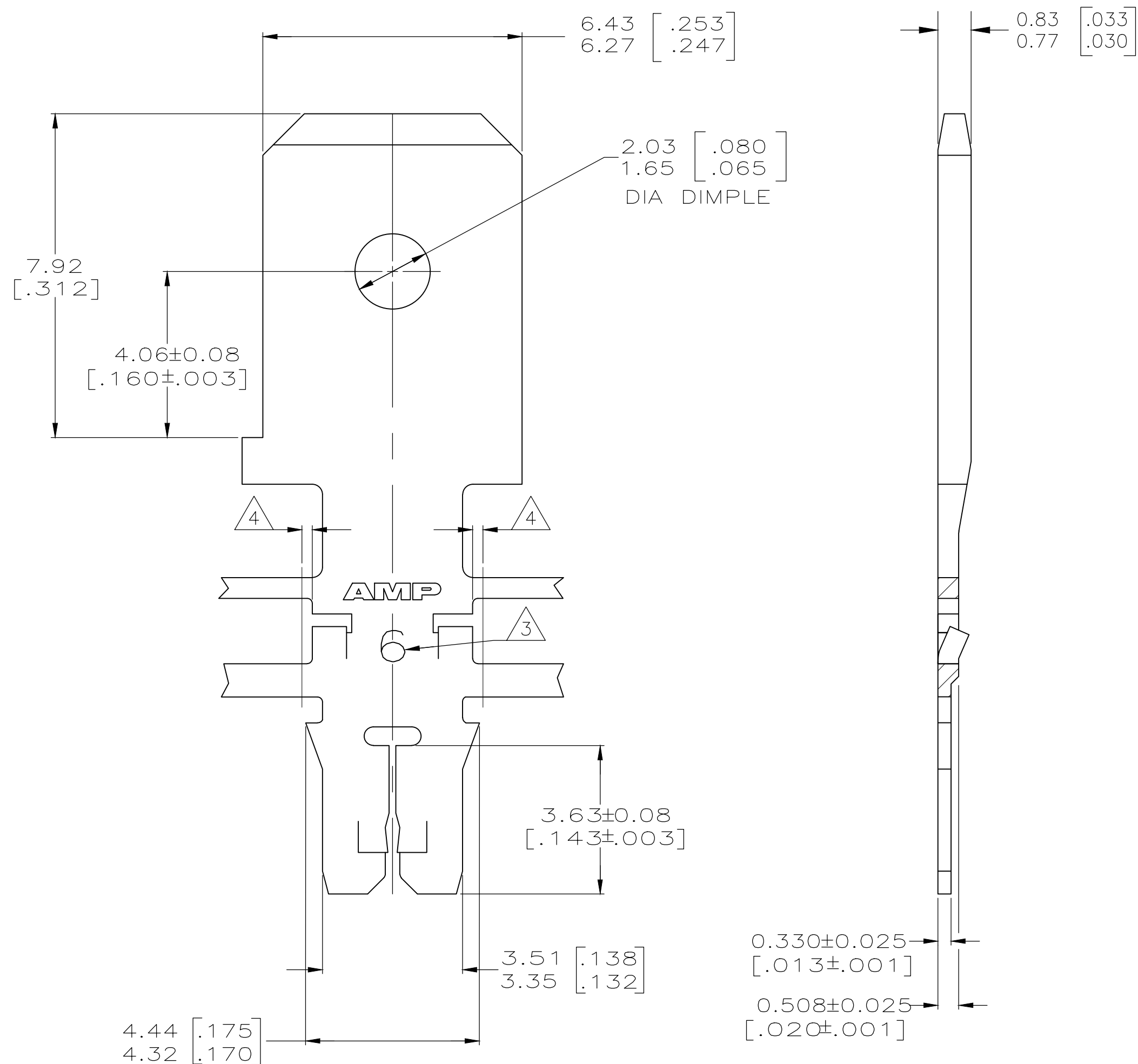

082 PRE-MILLED BRASS	63743-2
OBSOLETE 4M PRE-MILLED BRASS	63743-1
MATERIAL	PART NO

THIS DRAWING IS A CONTROLLED DOCUMENT.		DWN L.A.MAYER 9-1-93	TE TE Connectivity Ltd.	
DIMENSIONS: mm[INCHES]		CHK M.S. FEHER 9-1-93		
TOLERANCES UNLESS OTHERWISE SPECIFIED:		APVD A.HUNT III 9-1-93	NAME	
0 PLC ± -	1 PLC ± -	PRODUCT SPEC	TAB, 6.35 [.250] FASTON,™	
2 PLC ± 0.13 [.005]	3 PLC ± -	APPLICATION SPEC	MAG-MATE™ Slim Line	
4 PLC ± -	ANGLES ± -	108-1484	SIZE A2	CAGE CODE 00779
MATERIAL SEE TABLE	FINISH 0.002032 [.000080] MIN TIN PLATE	114-2140	DRAWING NO C-63743	RESTRICTED TO -
CUSTOMER DRAWING			SCALE 10:1	SHEET 1 OF 1
			REV H2	