

- Ideal for European 433.420 MHz Remote Control and Security Transmitters
- Very Low Series Resistance
- Quartz Stability
- Complies with Directive 2002/95/EC (RoHS)
- Tape and Reel Standard per ANSI/EIA-481
- Moisture Sensitivity Level: 1
- AEC-Q200 Qualified

RO3112D

**433.420 MHz
SAW
Resonator**

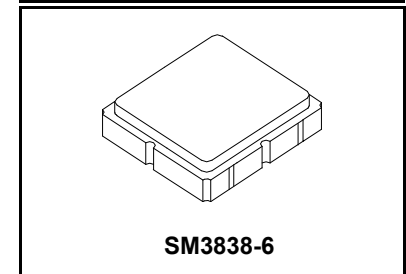

The RO3112D is a true one-port, surface-acoustic-wave (SAW) resonator in a surface-mount ceramic case. It provides reliable, fundamental-mode, quartz frequency stabilization of fixed-frequency transmitters operating at 433.420 MHz. This SAW is designed specifically for remote control and wireless security transmitters operating in Europe under ETSI I-ETS 300 220.

Absolute Maximum Ratings

| Rating | Value | Units |
|---|------------|-------|
| Input Power Level | 0 | dBm |
| DC Voltage | 12 | VDC |
| Storage Temperature | -40 to +85 | °C |
| Soldering Temperature (10 seconds / 5 cycles maximum) | 260 | °C |

Electrical Characteristics

| Characteristic | Sym | Notes | Minimum | Typical | Maximum | Units |
|--|--------------------------------------|--------------|------------------|-----------|----------|---------------------|
| Center Frequency, +25 °C | Absolute Frequency | f_C | 433.345 | | 433.495 | MHz |
| | Tolerance from 433.420 MHz | Δf_C | | | ± 75 | kHz |
| Insertion Loss | IL | | | 1.2 | 2.5 | dB |
| Quality Factor | Unloaded Q | Q_U | | 8400 | | |
| | 50 Ω Loaded Q | Q_L | | 1000 | | |
| Temperature Stability | Turnover Temperature | T_O | 10 | 25 | 40 | °C |
| | Turnover Frequency | f_O | | f_C | | |
| | Frequency Temperature Coefficient | FTC | | 0.032 | | ppm/°C ² |
| Frequency Aging | Absolute Value during the First Year | $ f_A $ | | ≤ 10 | | ppm/yr |
| DC Insulation Resistance between Any Two Terminals | | | 1.0 | | | M Ω |
| RF Equivalent RLC Model | Motional Resistance | R_M | | 13.7 | | Ω |
| | Motional Inductance | L_M | | 42.2 | | μH |
| | Motional Capacitance | C_M | | 3.2 | | fF |
| | Shunt Static Capacitance | C_O | | 3.7 | | pF |
| Test Fixture Shunt Inductance | L_{TEST} | | | 36.2 | | nH |
| Lid Symbolization (Y = Year, WW = Week, S = Shift) | | | 683, YWWS | | | |
| Standard Reel Quantity | Reel Size 7 Inch | | 500 Pieces/Reel | | | |
| | Reel Size 13 Inch | | 3000 Pieces/Reel | | | |

CAUTION: Electrostatic Sensitive Device. Observe precautions for handling.

NOTES:

1. The design, manufacturing process, and specifications of this device are subject to change.
2. US or International patents may apply.
3. RoHS compliant from the first date of manufacture.

Electrical Connections

The SAW resonator is bidirectional and may be installed with either orientation. The two terminals are interchangeable and unnumbered. The callout NC indicates no internal connection. The NC pads assist with mechanical positioning and stability. External grounding of the NC pads is recommended to help reduce parasitic capacitance in the circuit.

| Pin | Connection |
|-----|------------|
| 1 | NC |
| 2 | Terminal |
| 3 | NC |
| 4 | NC |
| 5 | NC |
| 6 | Terminal |
| 7 | NC |
| 8 | NC |

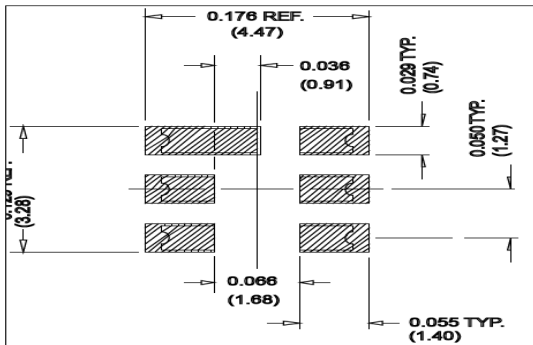
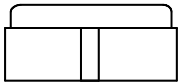
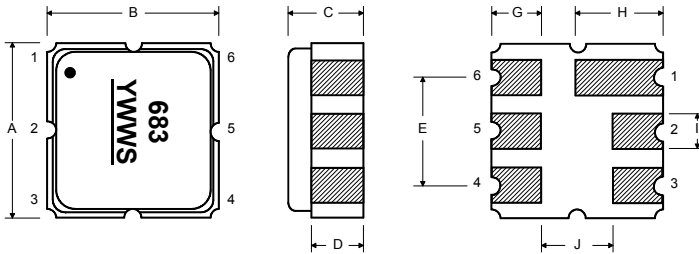

Case Dimensions

| Dimension | mm | | | Inches | | |
|-----------|------|------|------|--------|-------|-------|
| | Min | Nom | Max | Min | Nom | Max |
| A | 3.60 | 3.80 | 4.00 | 0.142 | 0.150 | 0.157 |
| B | 3.60 | 3.80 | 4.00 | 0.142 | 0.150 | 0.157 |
| C | 1.10 | 1.30 | 1.50 | 0.043 | 0.050 | 0.060 |
| D | 0.95 | 1.10 | 1.25 | 0.037 | 0.043 | 0.049 |
| E | 2.39 | 2.54 | 2.69 | 0.094 | 0.100 | 0.106 |
| G | 0.90 | 1.00 | 1.10 | 0.035 | 0.040 | 0.043 |
| H | 1.90 | 2.00 | 2.10 | 0.748 | 0.079 | 0.083 |
| I | 0.50 | 0.60 | 0.70 | 0.020 | 0.024 | 0.028 |
| J | 1.70 | 1.80 | 1.90 | 0.067 | 0.071 | 0.075 |

Equivalent RLC Model

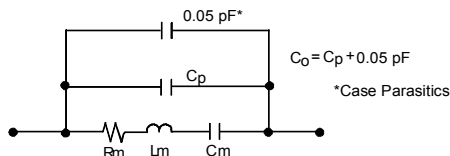

Parameter Test Circuit

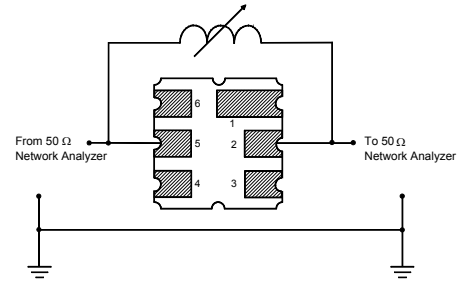

Power Test Circuit

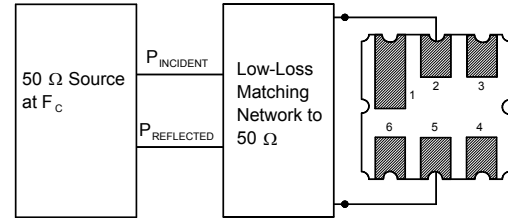

Example Application Circuits

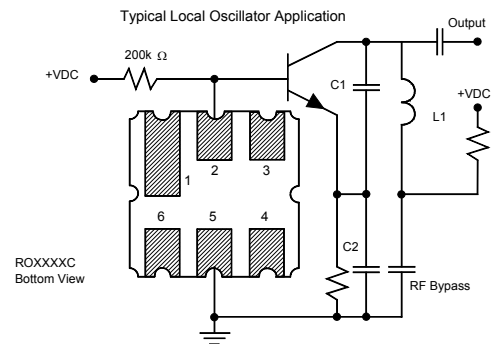
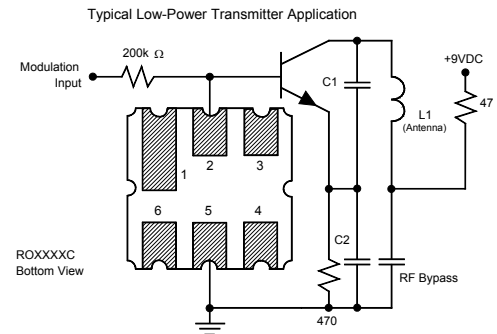

Temperature Characteristics

The curve shown on the right accounts for resonator contribution only and does not include LC component temperature contributions.

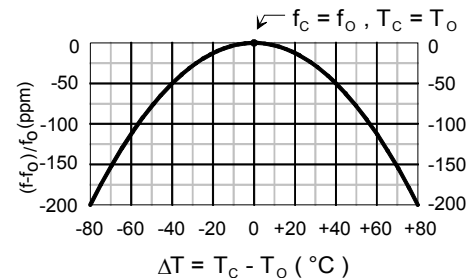

Recommended Reflow Profile

1. Preheating shall be fixed at 150~180°C for 60~90 seconds.
2. Ascending time to preheating temperature 150°C shall be 30 seconds min.
3. Heating shall be fixed at 220°C for 50~80 seconds and at 260°C +0/-5°C peak (10 seconds).
4. Time: 5 times maximum.

