

## Assembly instructions for SRC

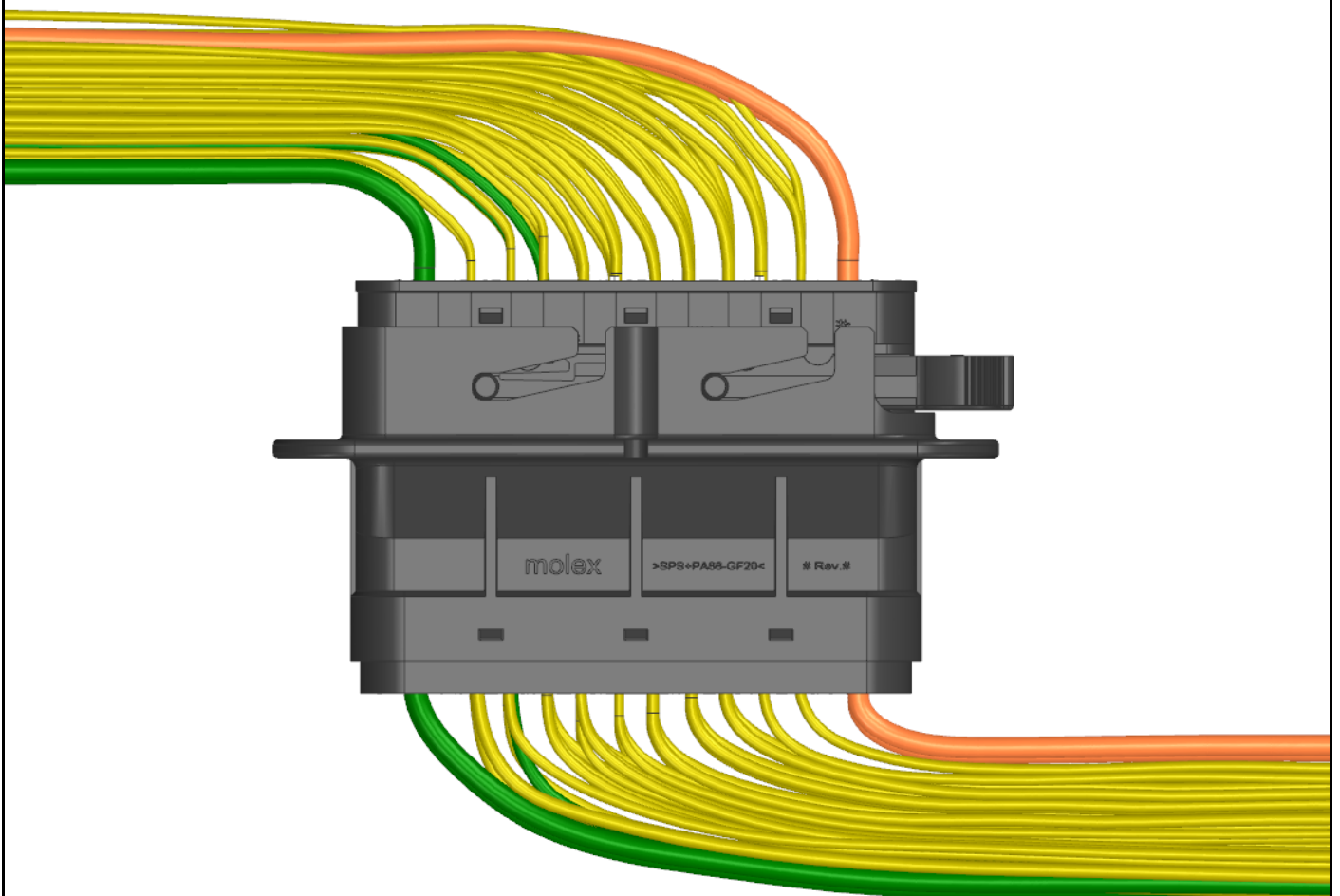

Scan for more information

REVISION: <b>C1</b>	ECR/ECN INFORMATION: ECM No: 170475 DATE:	TITLE: <b>SRC2 &amp; SRC MIXED POWER APPLICATION SPECIFICATION</b>	SHEET No. <b>1 of 52</b>
DOCUMENT NUMBER: <b>850830010 PSA</b>	CREATED / REVISED BY: <b>SOBRIEN01</b>	CHECKED BY: <b>AJOBRIEN</b>	APPROVED BY:
<small>TEMPLATE FILENAME: APPLICATION_SPEC[SIZE_A4](V.1).DOC</small>			

# Table of contents



**Tools required**  
- Page 4

**PLEASE READ DISCLAIMER AND RECOMMENDATION NOTES ON PAGE 51 BEFORE USING THIS DOCUMENT**

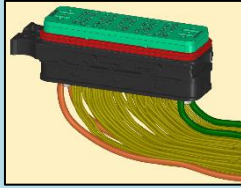

**Female assembly overview**  
- Page 5

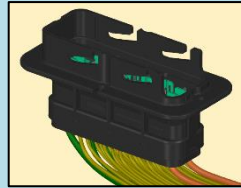

**Male assembly overview**  
- Page 21

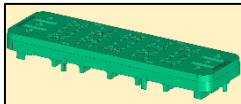

**Open TPA**  
- Page 6

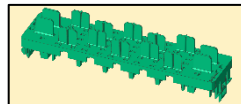

**Open TPA**  
- Page 22

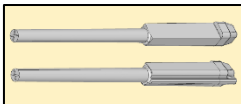

**Signal blind cavity plug**  
- Page 7

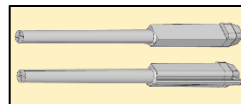

**Signal blind cavity plug**  
- Page 23

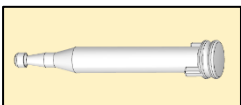

**Power blind cavity plug**  
- Page 11

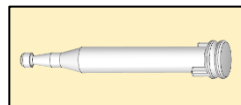

**Power blind cavity plug**  
- Page 25

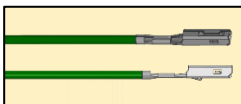

**Signal terminals**  
- Page 12

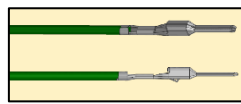

**Signal terminals**  
- Page 26



**2.5mm<sup>2</sup> terminals**  
- Page 13

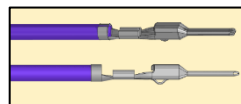

**2.5mm<sup>2</sup> terminals**  
- Page 27

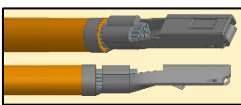

**Power terminals**  
- Page 14

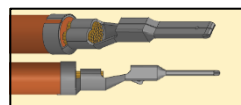

**Power terminals**  
- Page 28

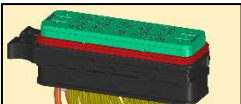

**Close TPA**  
- Page 15

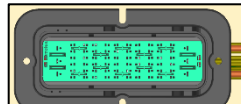

**Close TPA**  
- Page 29



**Attach conduit interface**  
- Page 16



**Attach conduit interface**  
- Page 31

Table of contents continued on next page

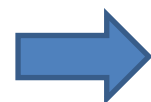



**Visual inspection**  
- Page 36

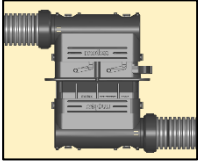

**Final connector mating**  
- Page 37

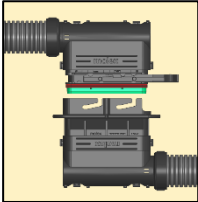

**Connector un-mating**  
- Page 40

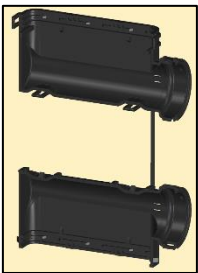

**Conduit interface removal**  
- Page 41

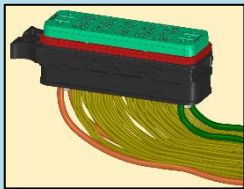

**Female connector maintenance**

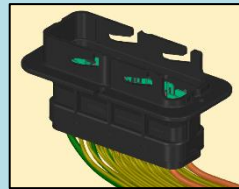

**Male connector maintenance**

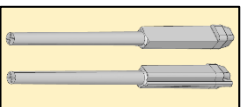

**Signal blind cavity plug removal**  
- Page 43

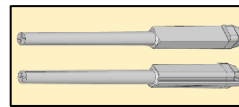

**Signal blind cavity plug removal**  
- Page 47

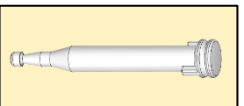

**Power blind cavity plug removal**  
- Page 44

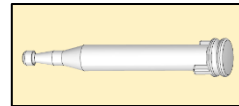

**Power blind cavity plug removal**  
- Page 48

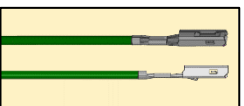

**Signal and 2.5mm<sup>2</sup> terminals removal**  
- Page 45

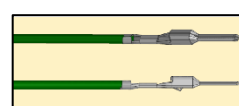

**Signal and 2.5mm<sup>2</sup> terminals removal**  
- Page 49

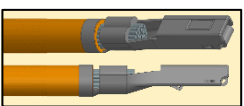

**Power terminals removal**  
- Page 46

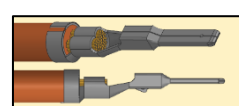

**Power terminals removal**  
- Page 50

**Disclaimer and reference documents**  
- Page 51

## Tools required

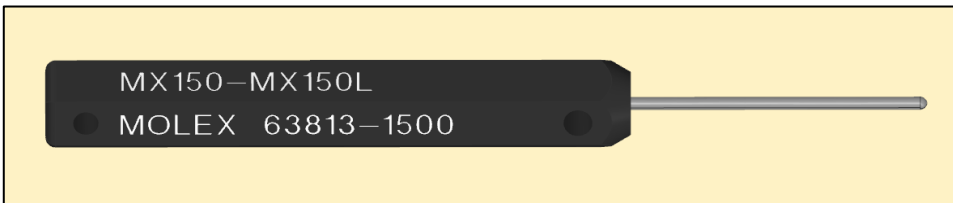
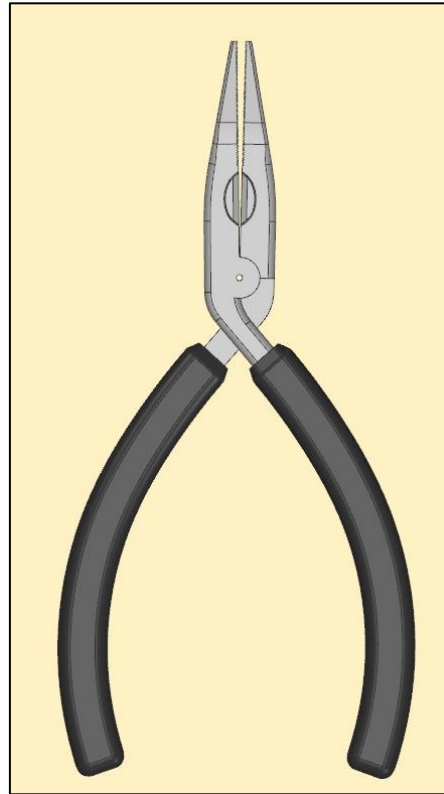
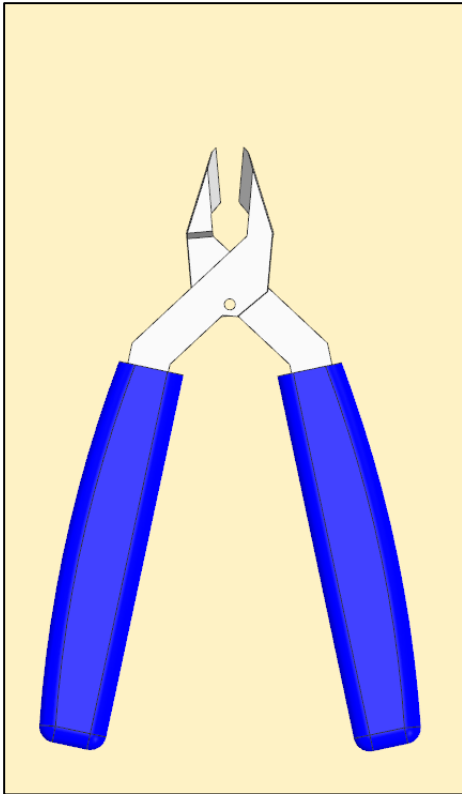

# Female assembly overview

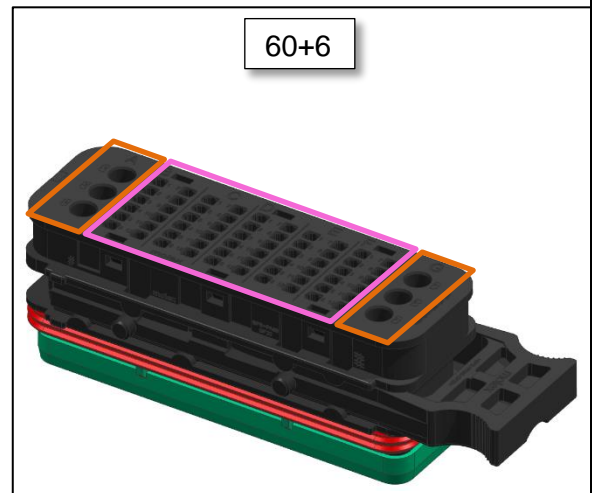
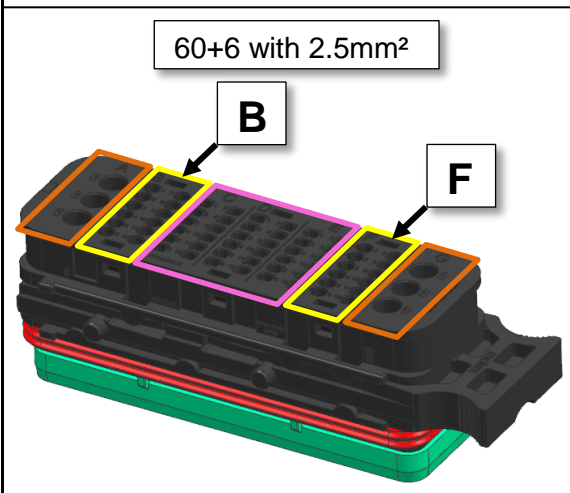

- 2.5mm<sup>2</sup> only available on some configurations and only in **B and F** locations as highlighted in yellow above
- For all configurations please see 850840700 PSD & 932870001 PSD

## Power



**Power**  
Cable Insulation  
Diameter Range  
3.0 – 5.0mm

## 2.5mm<sup>2</sup>

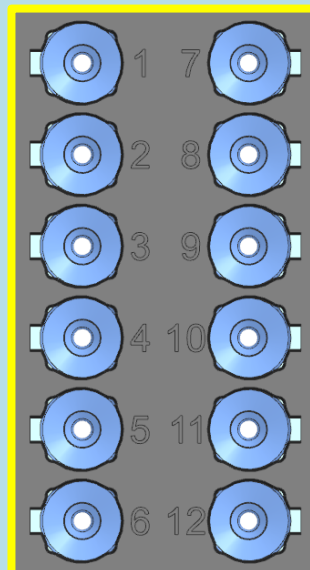

**2.5mm<sup>2</sup>**  
Cable Insulation  
Diameter Range  
1.5 – 3.0mm

## Signal

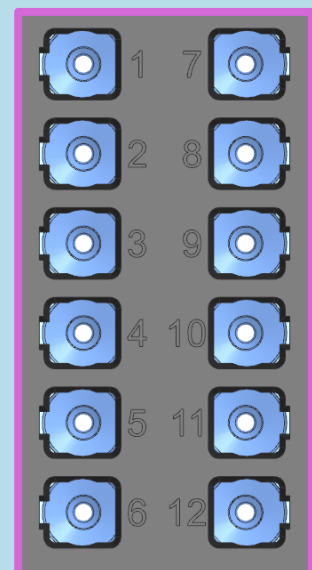

**Signal**  
Cable Insulation  
Diameter Range  
1.5 - 2.7mm

# Step 1 – open TPA

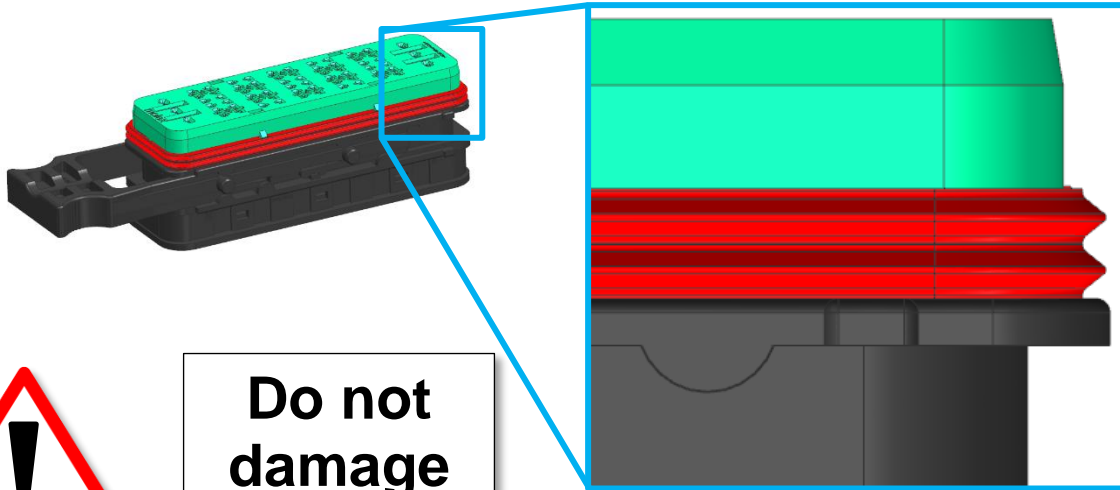

**Do not  
damage  
the seal**

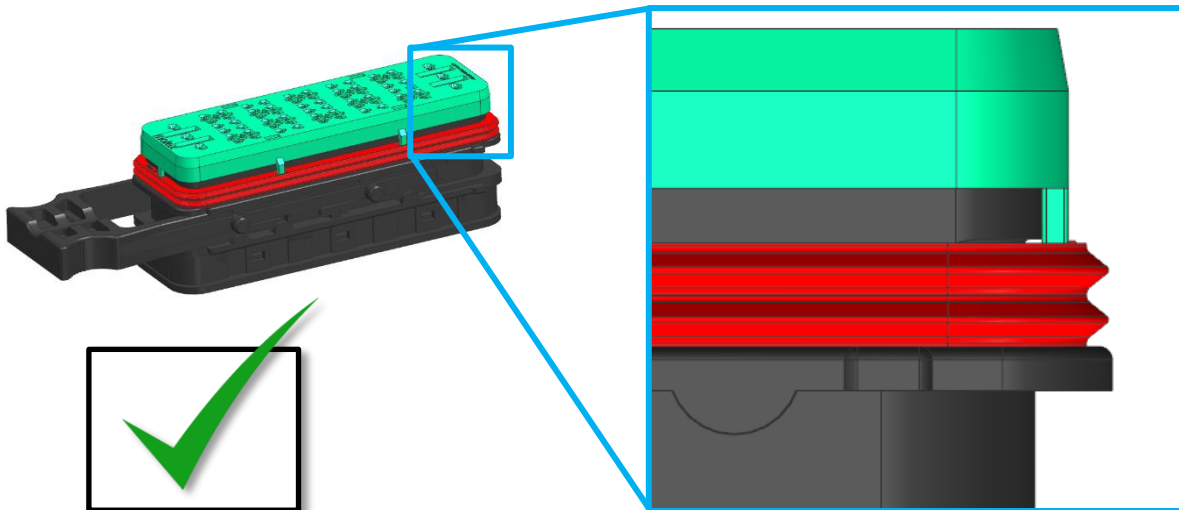
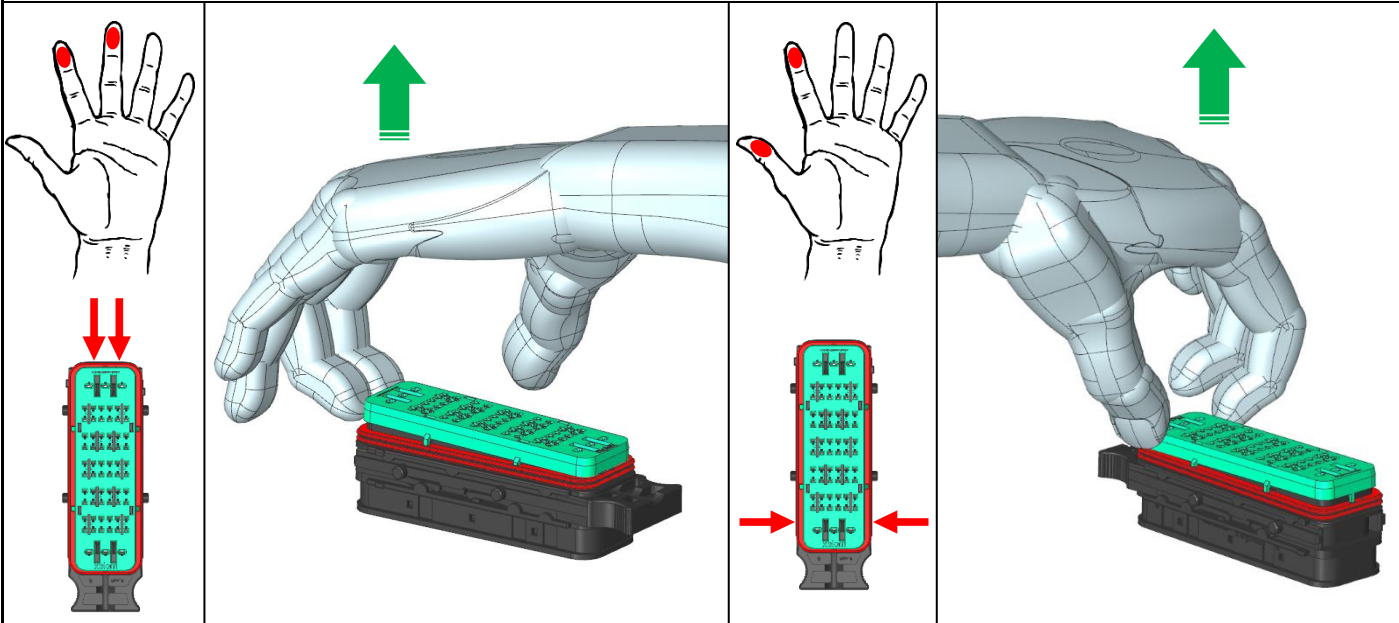

## Step 2 – insert signal blind cavity plugs

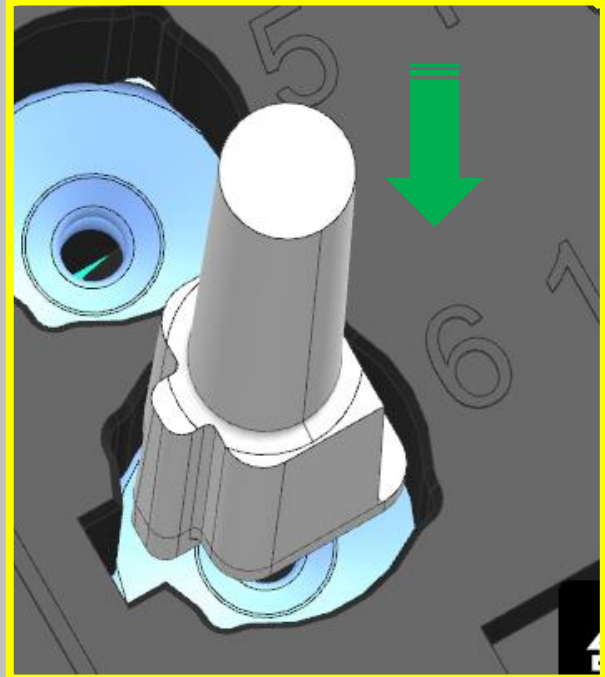
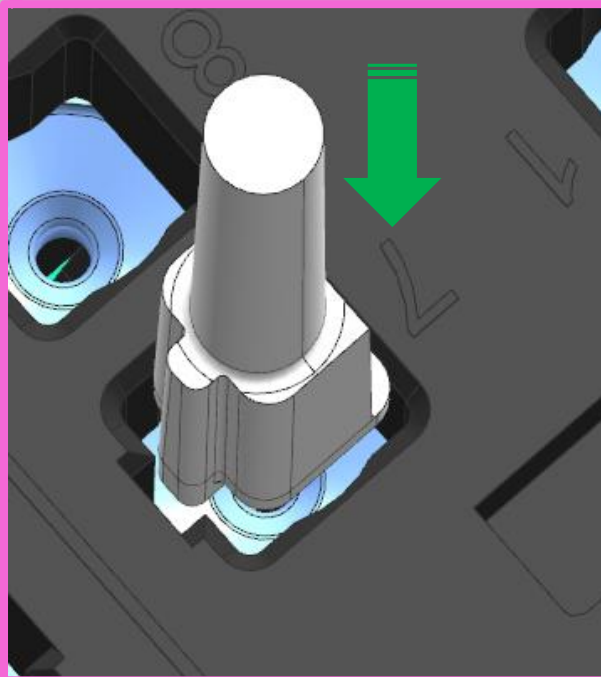
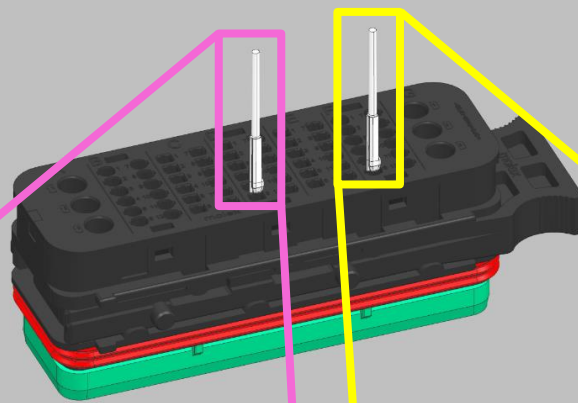
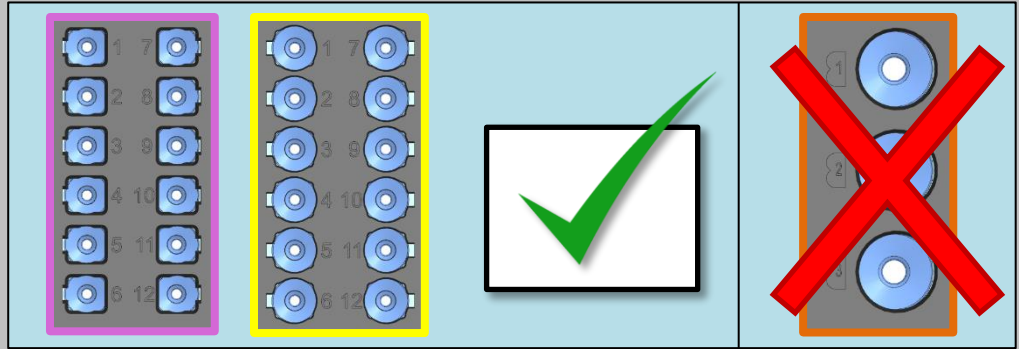
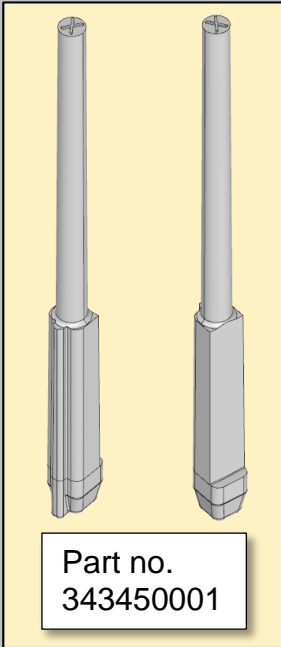

**Demonstration example**



**See next page**

## Step 2 – insert signal blind cavity plugs

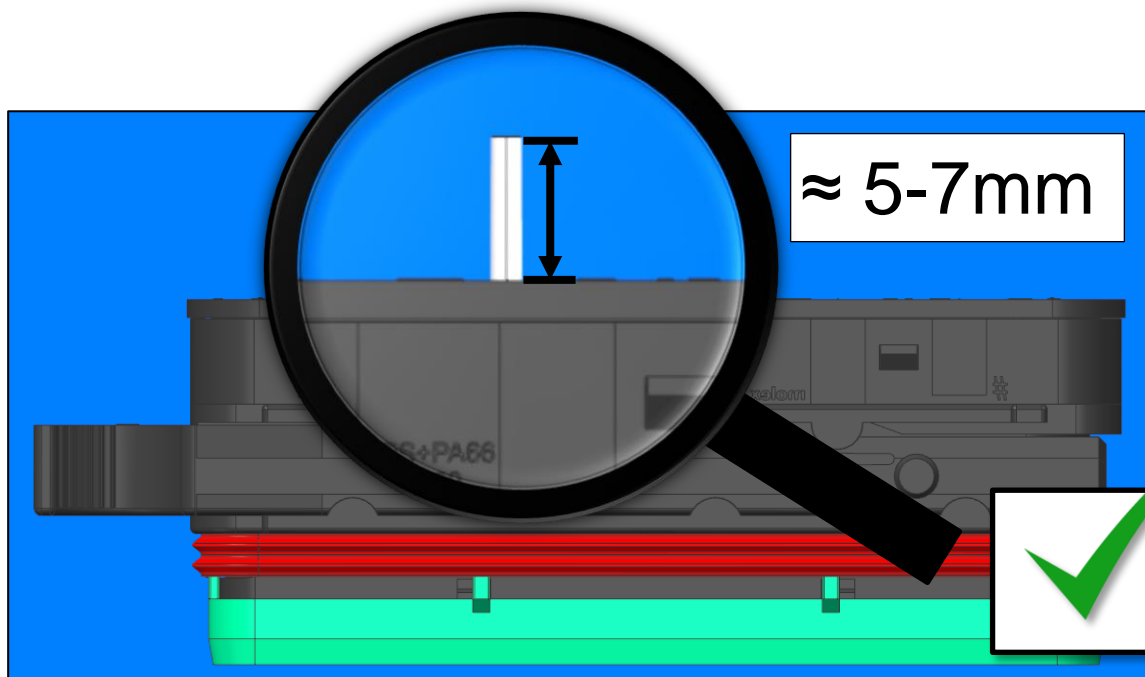
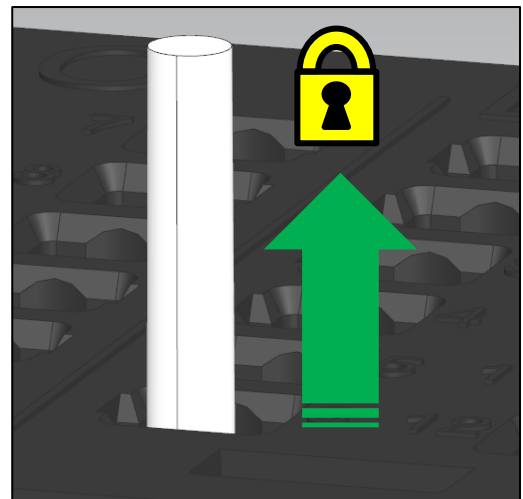
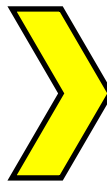
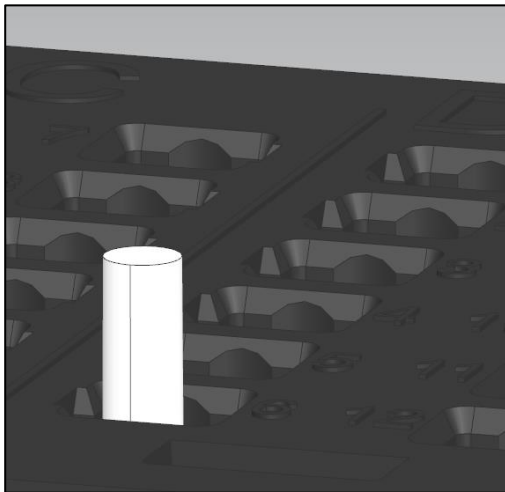
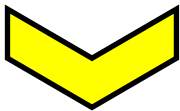
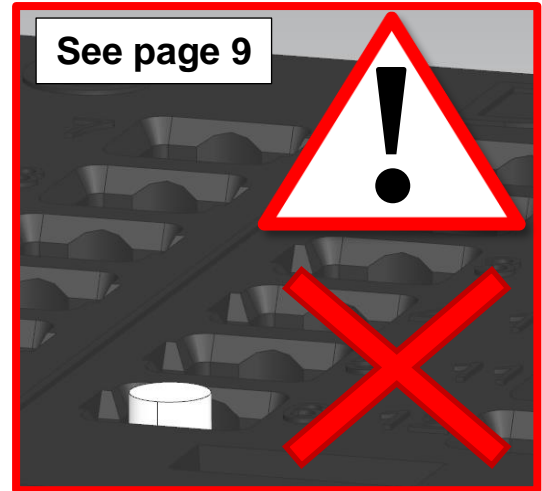
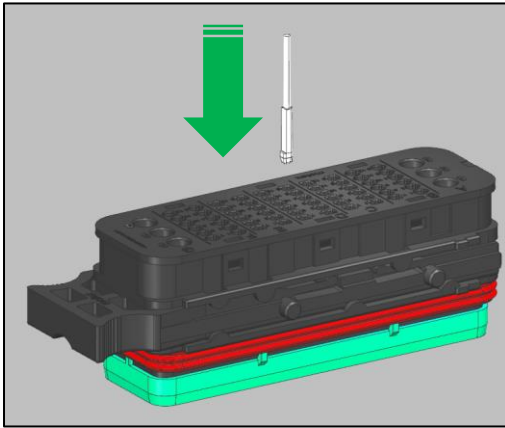



**If this happens**



**Tool required**

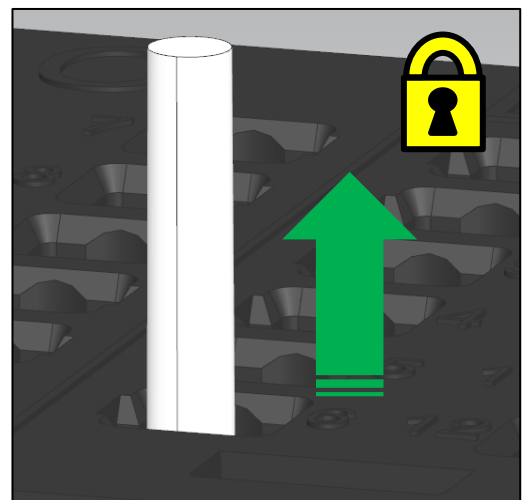
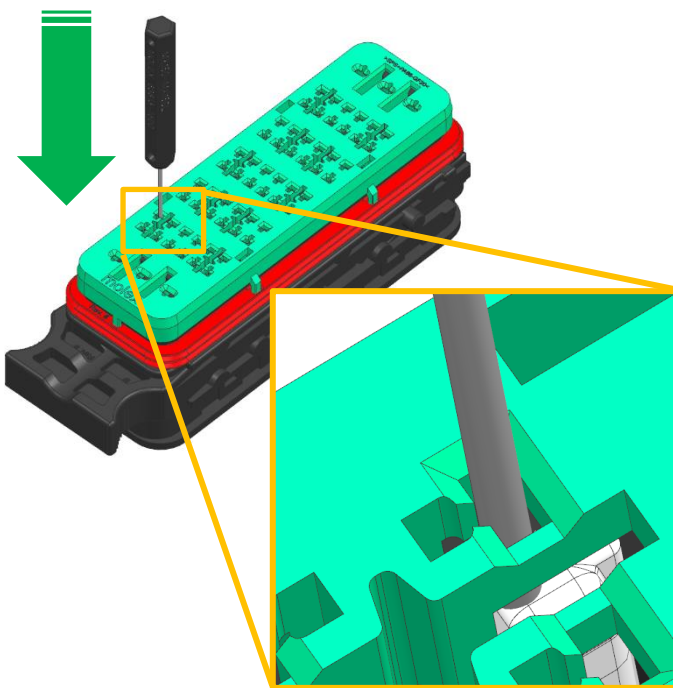
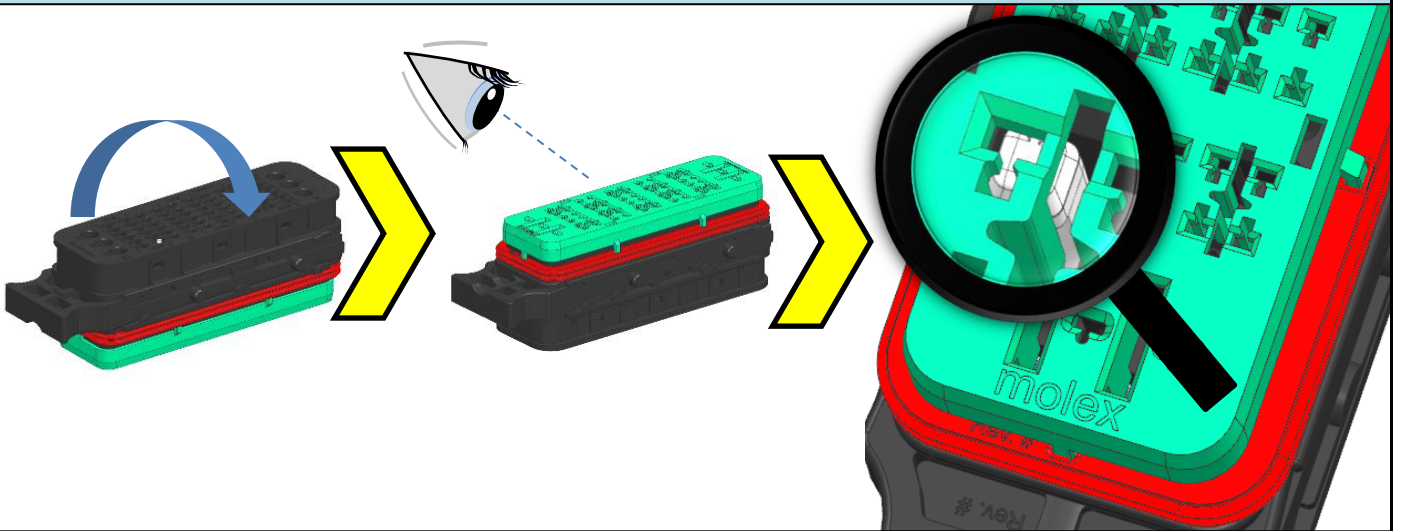
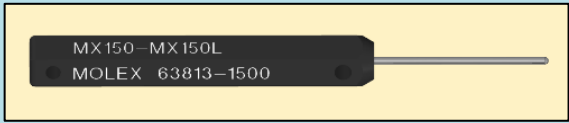

# Step 2.1 – trim signal blind cavity plugs (recommended)

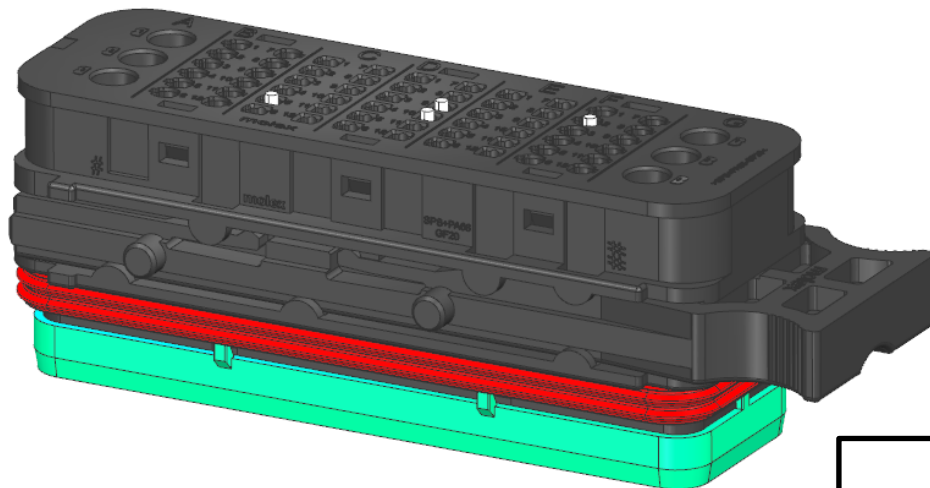
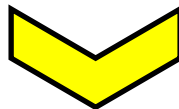
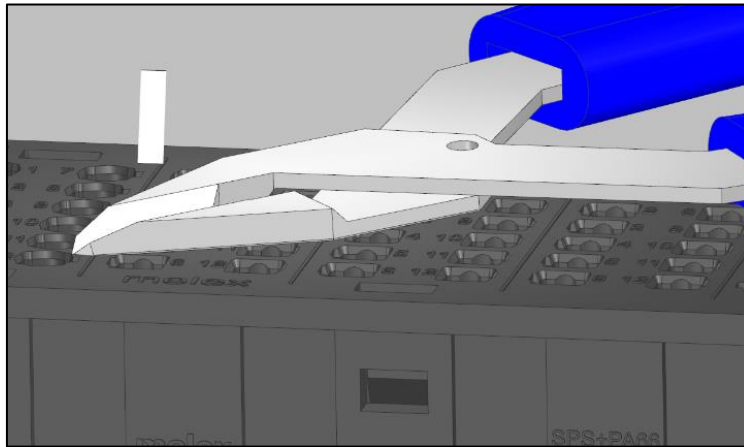
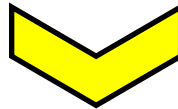
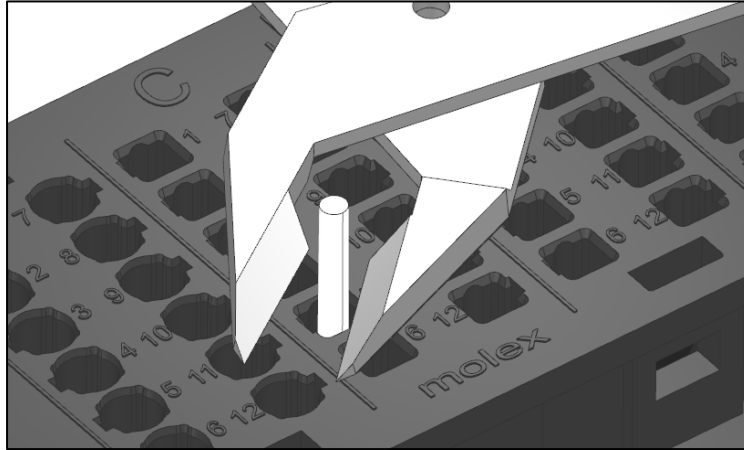
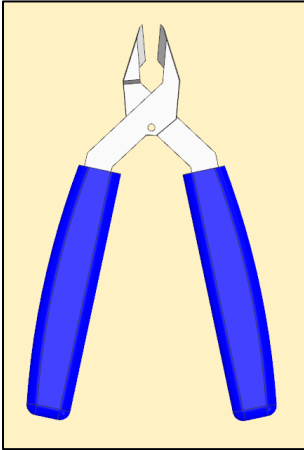

**Demonstration example**



# Step 3 – insert power blind cavity plugs

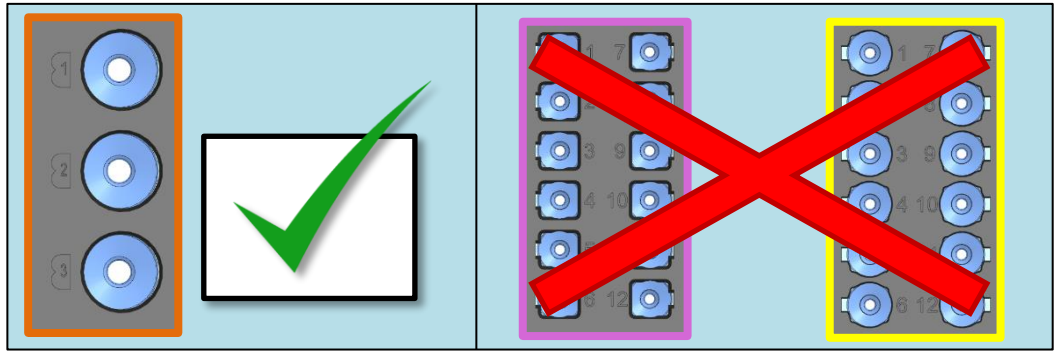
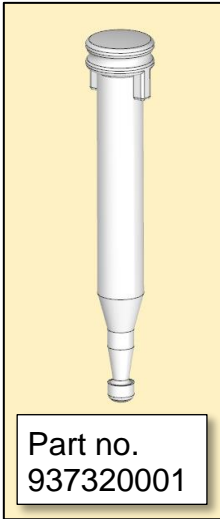

**Demonstration example**

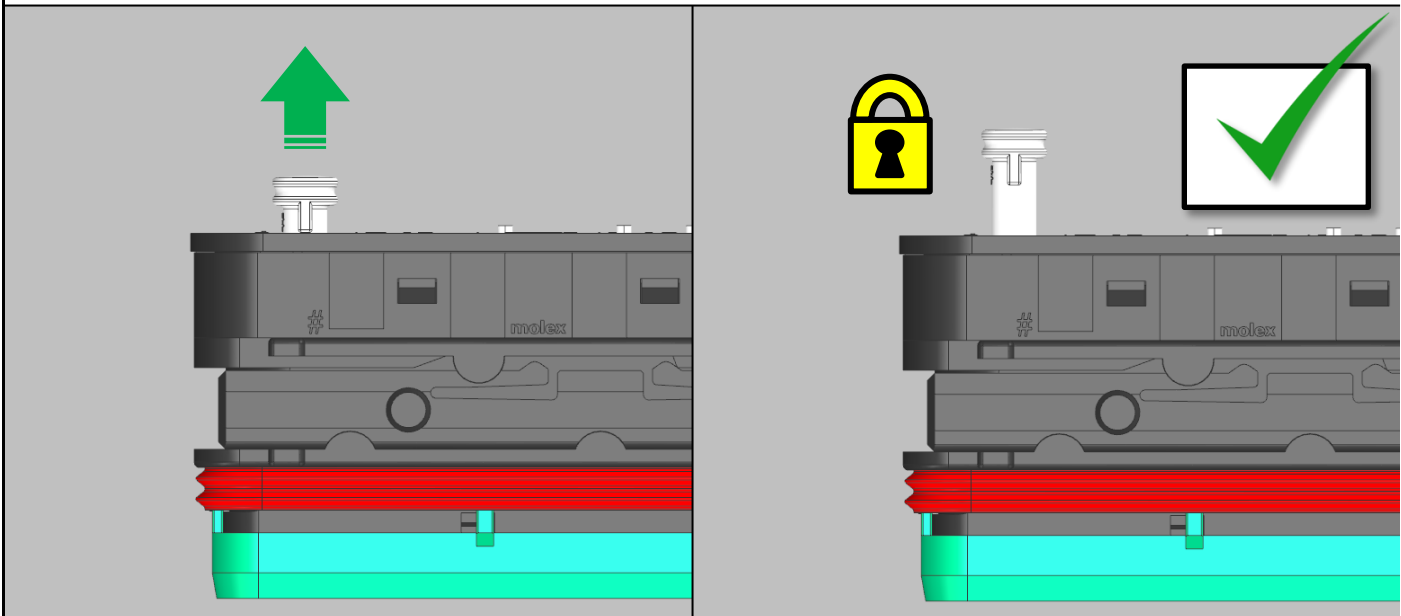
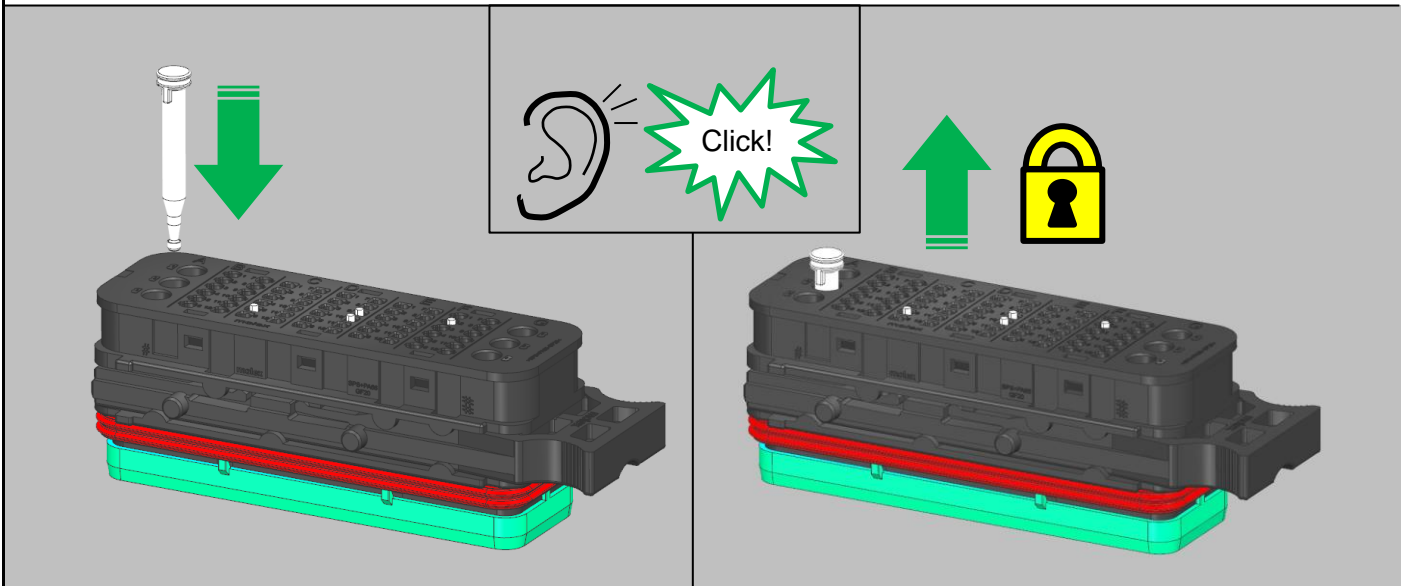

# Step 4 – insert signal terminals

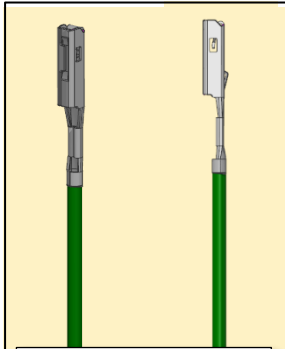

Part no. see sales drawing SD-33012-002

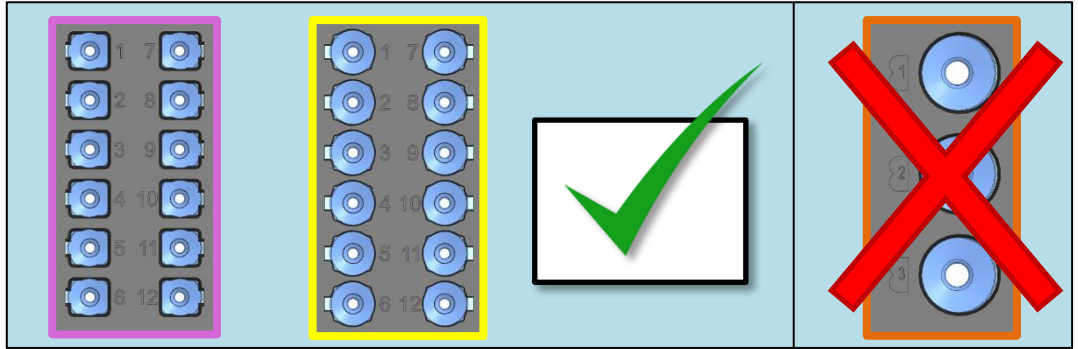

**Signal**  
Cable Insulation Diameter Range 1.5 - 2.7mm

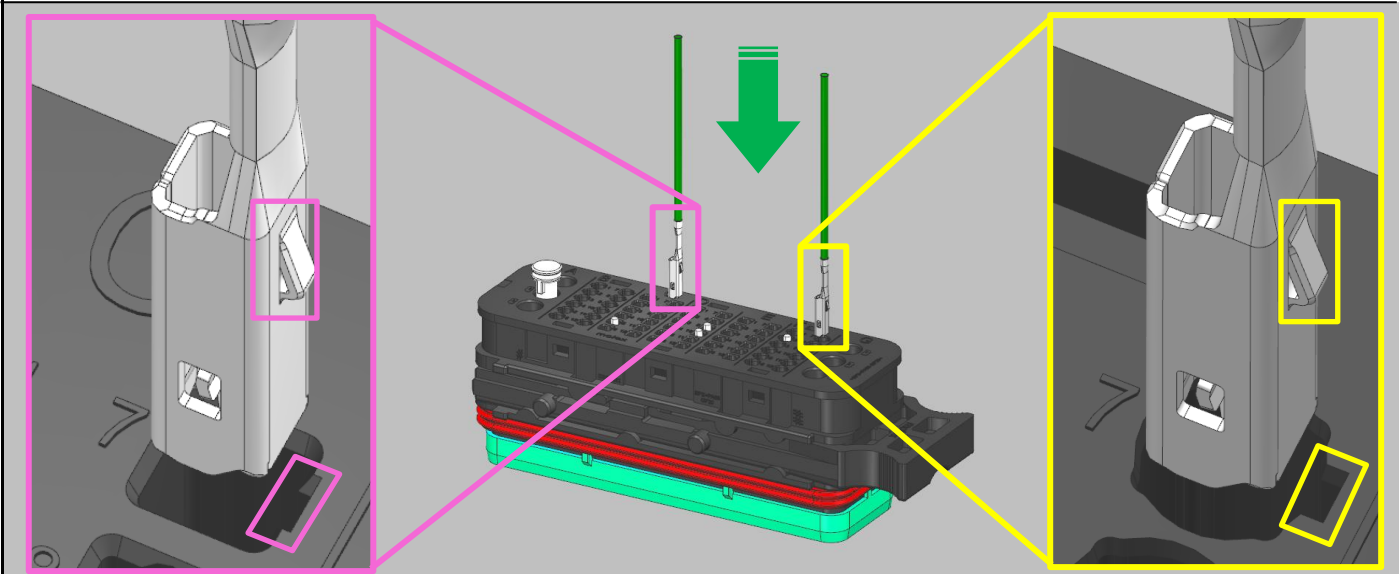

## Demonstration example

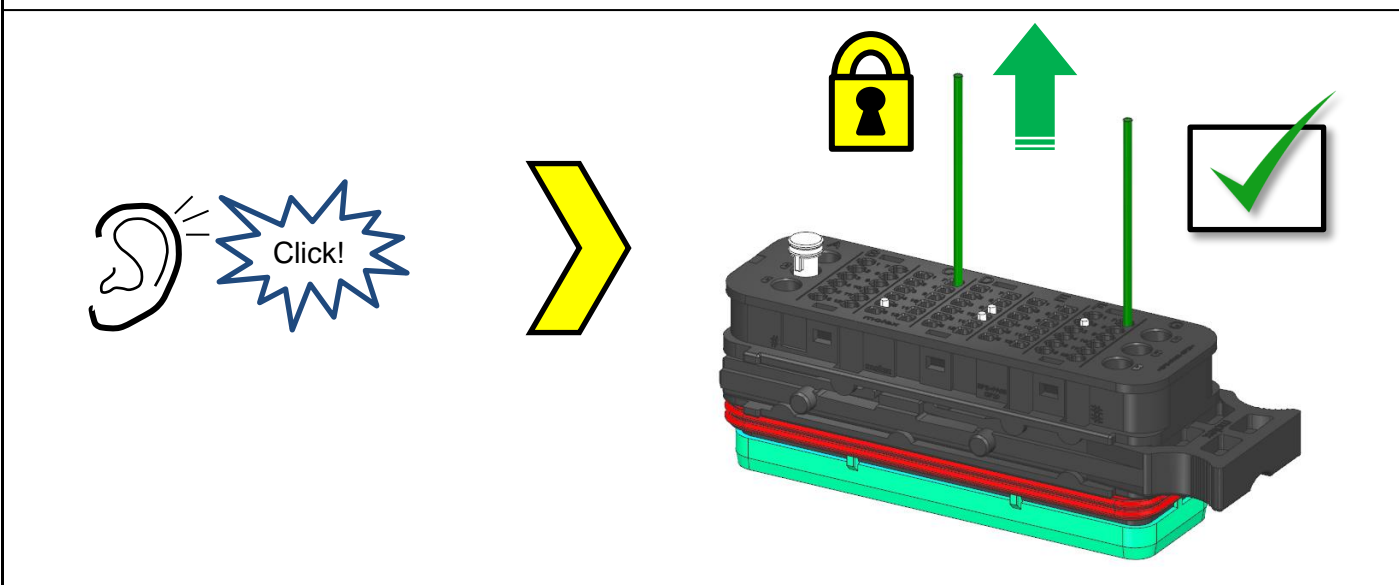

# Step 5 – insert 2.5mm<sup>2</sup> (13awg) terminal

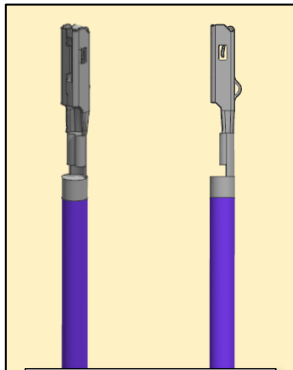

Part no. see sales drawing 936430010 PSD

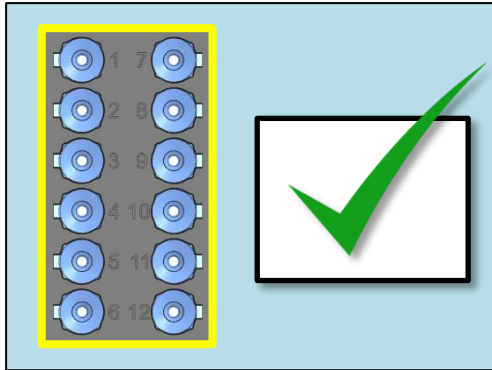

**2.5mm<sup>2</sup>**  
Cable Insulation Diameter  
Range 1.5 – 3.0mm

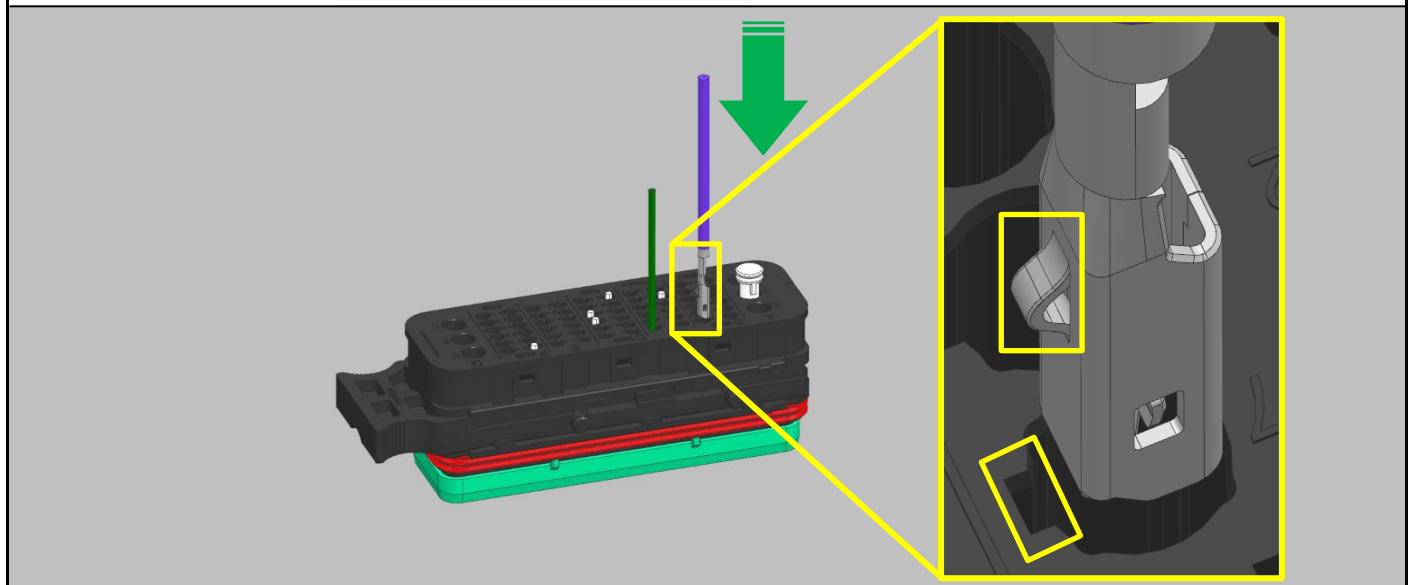
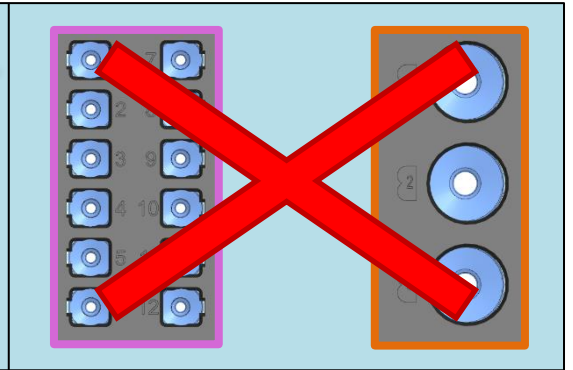

## Demonstration example

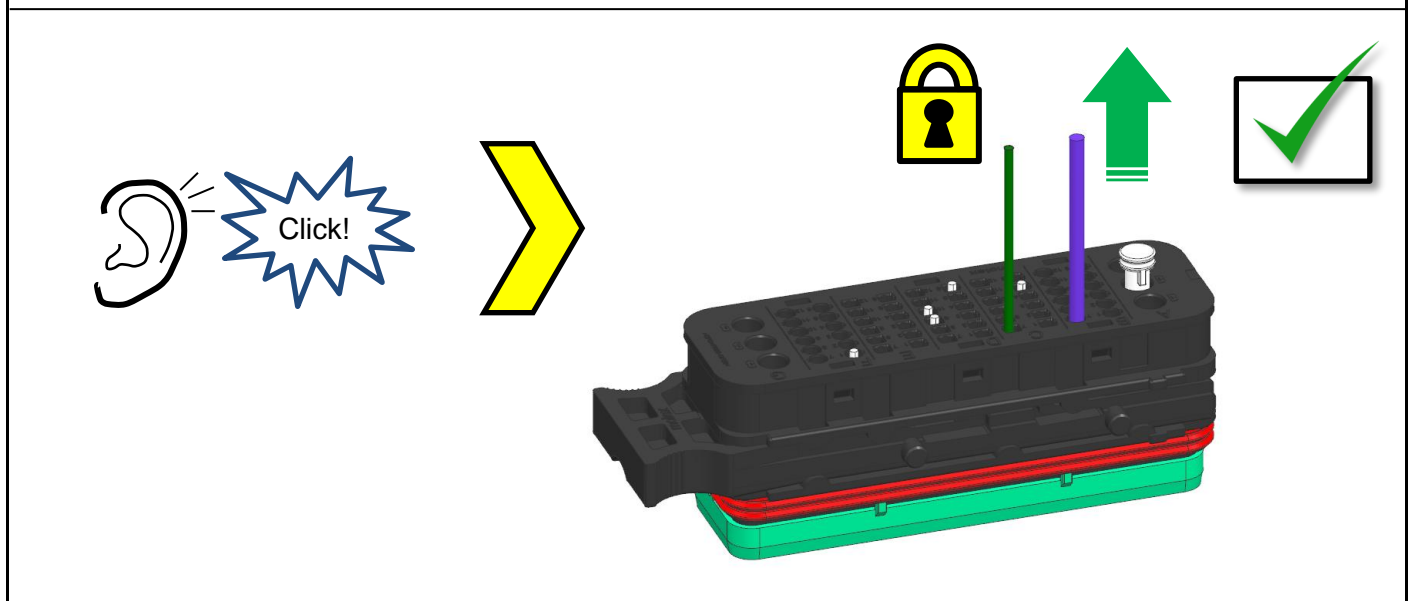

## Step 6 – insert power terminals

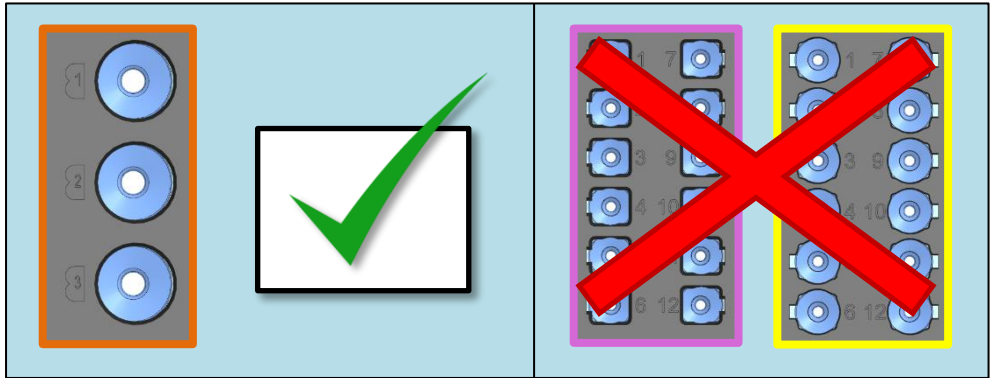
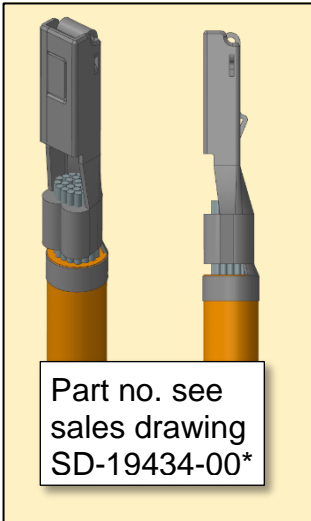

**Power**  
Cable Insulation Diameter  
Range 3.0 – 5.0mm



Insert terminal nose carefully through seal opening

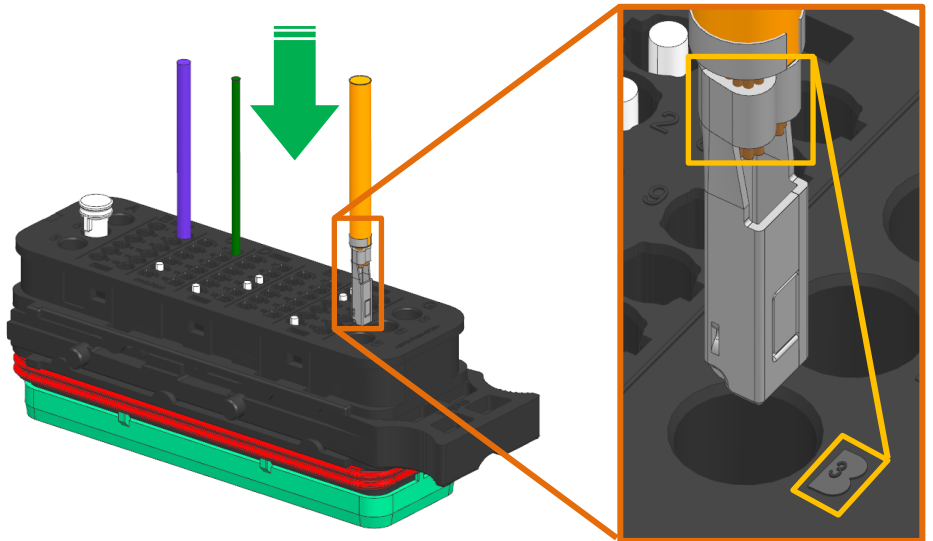

### Demonstration example

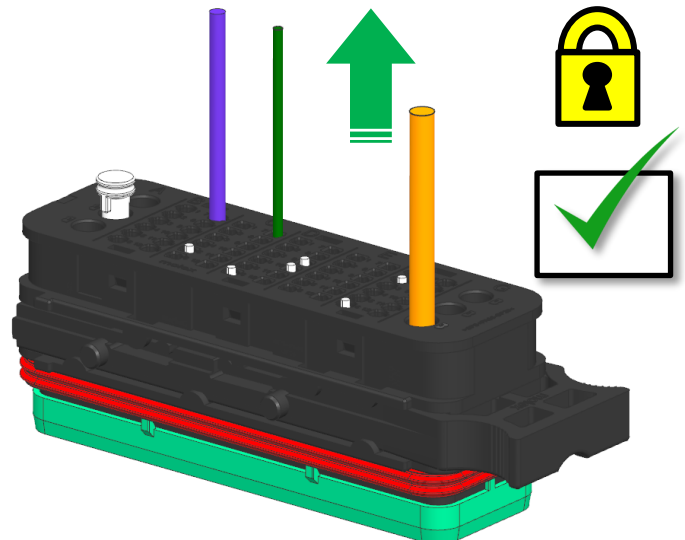
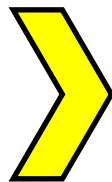

## Step 7 – close tpa



**Populate connector fully  
no holes left empty**

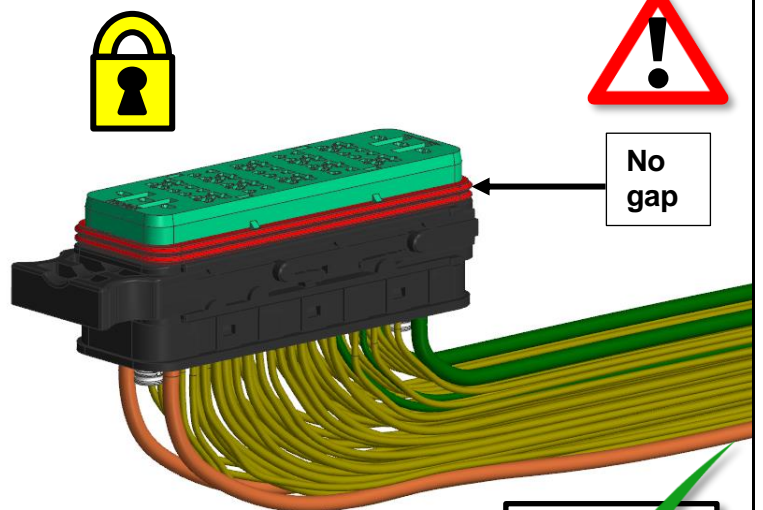
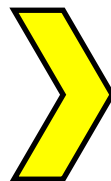
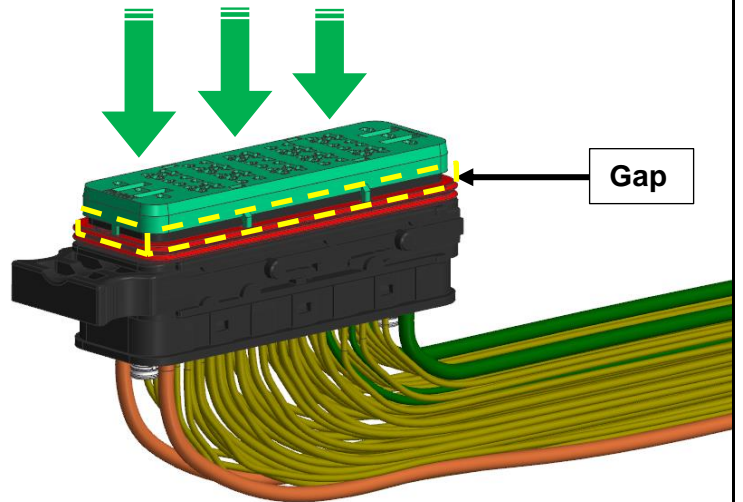
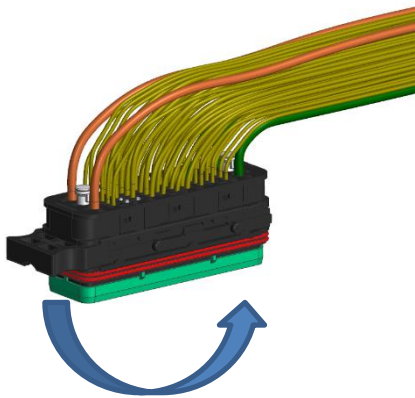
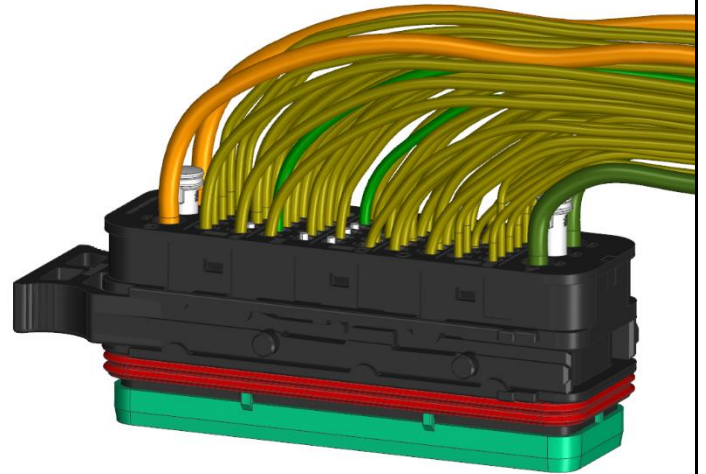



- Various configurations of wire dress available.
  - 1 – 3 open exits
  - 4 different exit sizes
- See sales drawing: 934811000 PSD
- Appropriate conduit must be used with wire dress
- Example shown for demonstration only
- Direction of exit(s) per wiring diagram

### Tool & parts needed

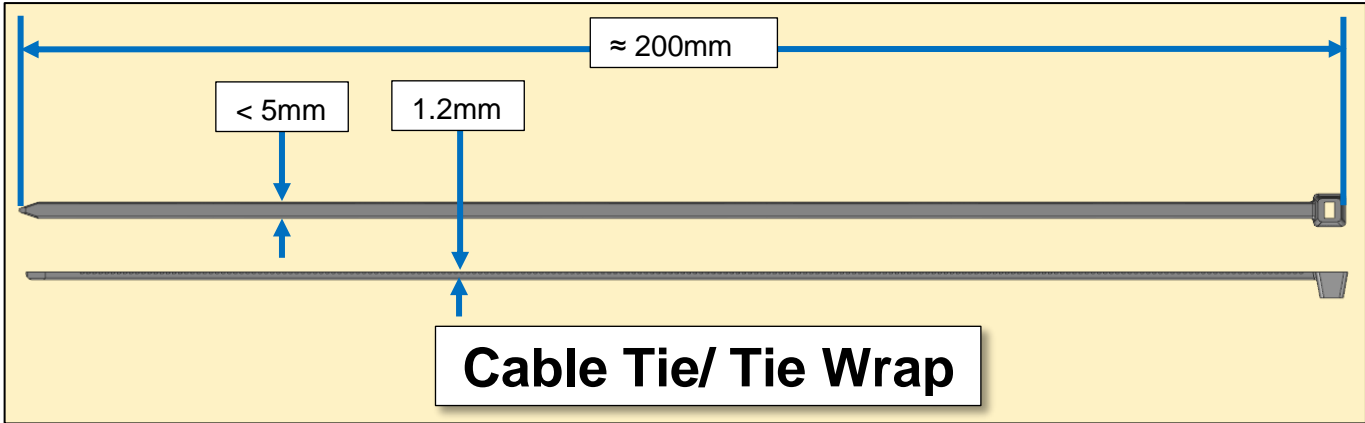
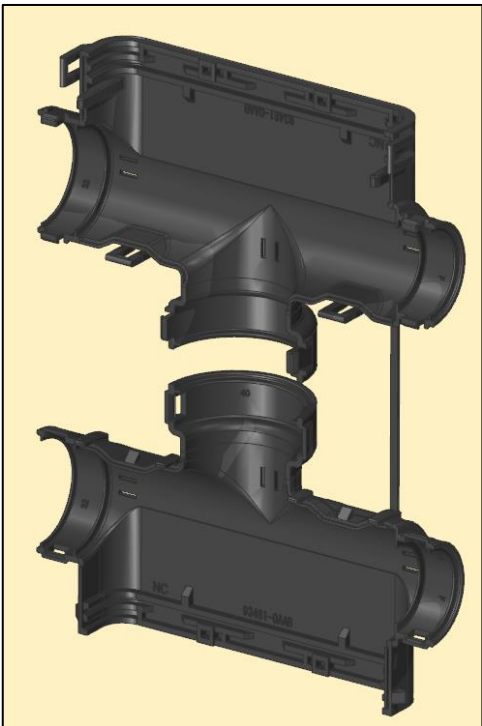
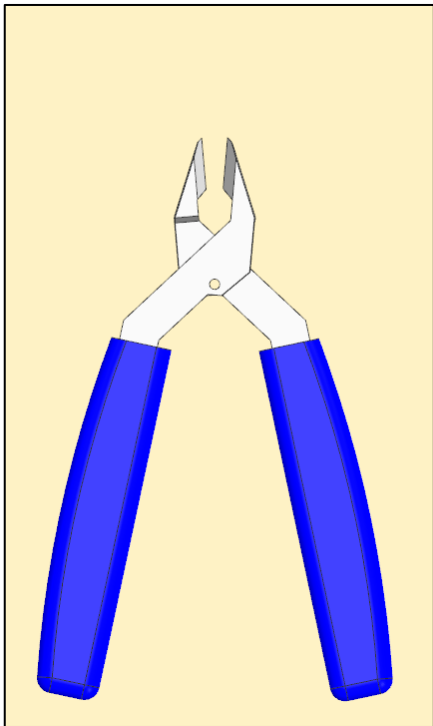



# Recommended assembly sequence

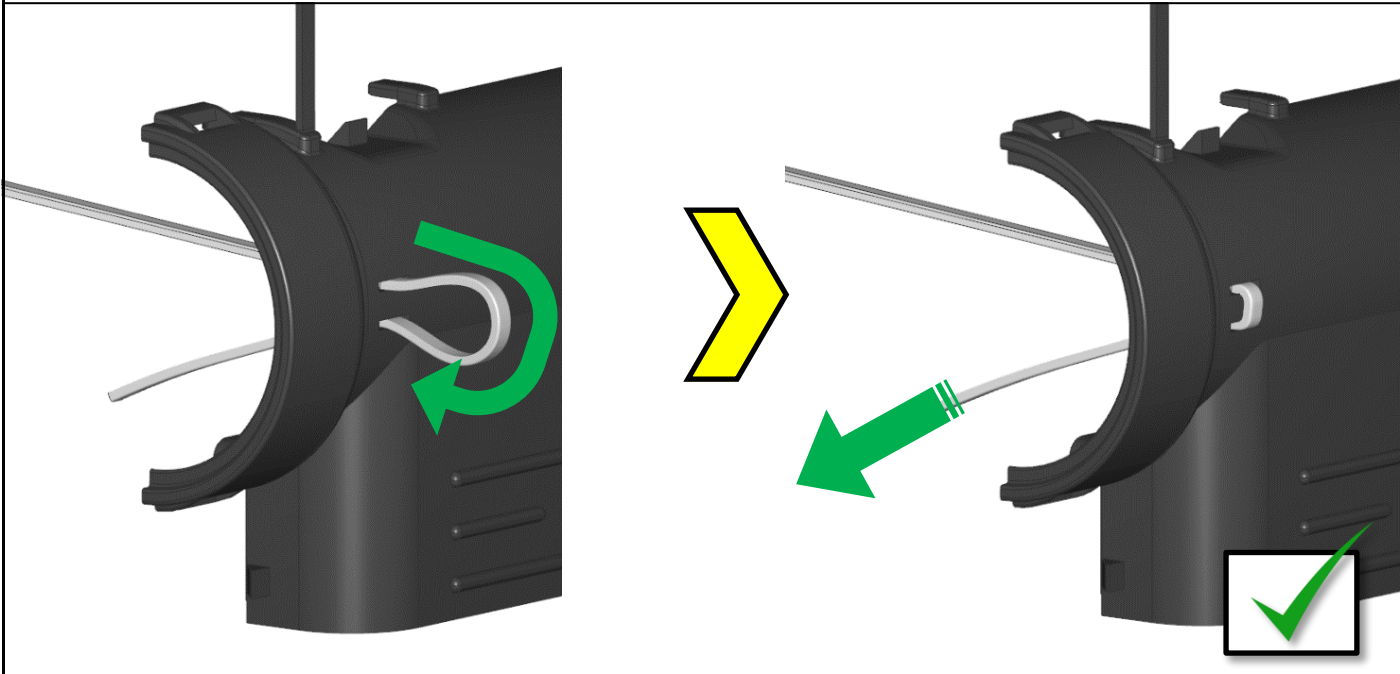
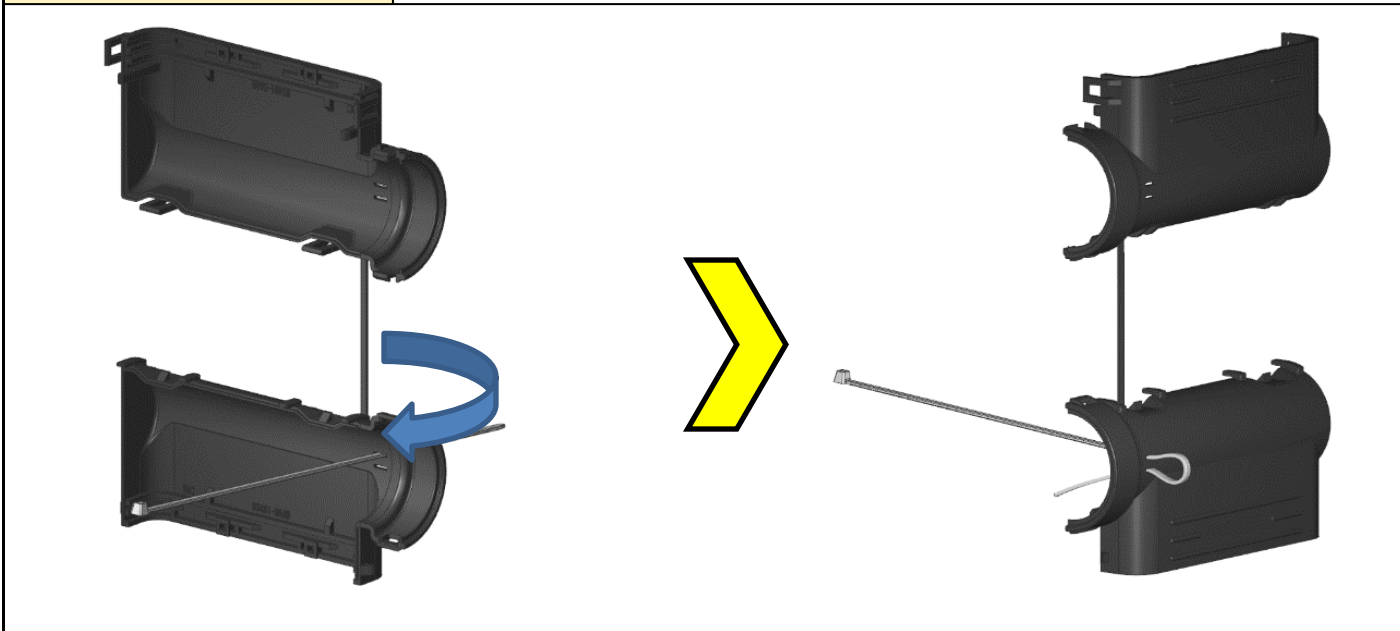
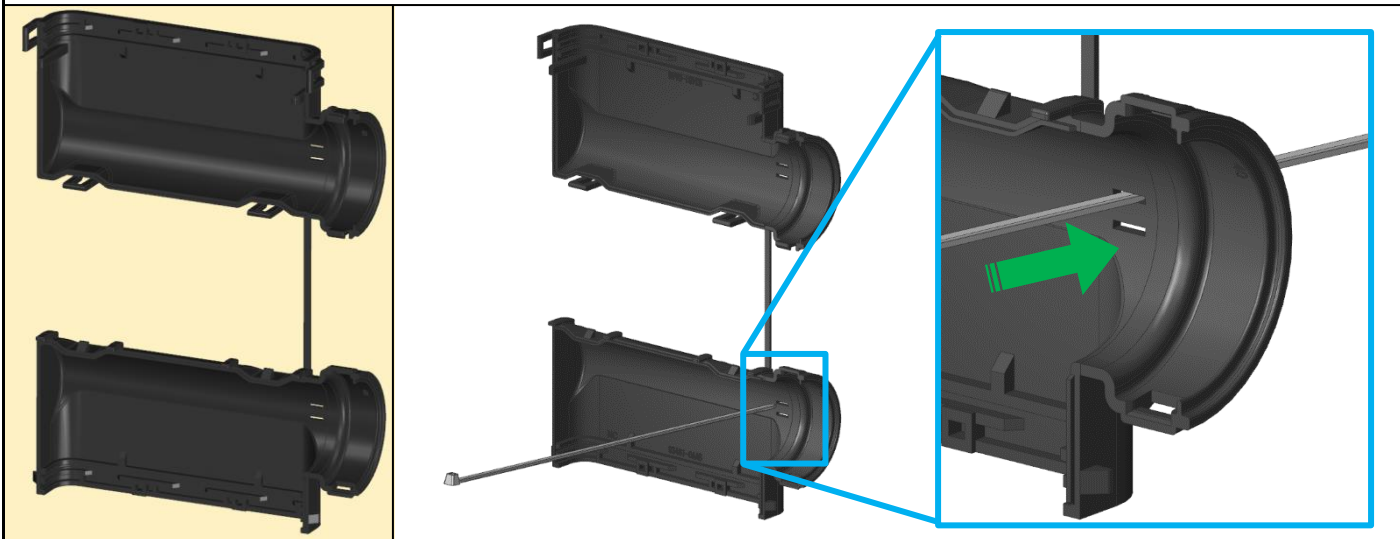

# Recommended assembly sequence

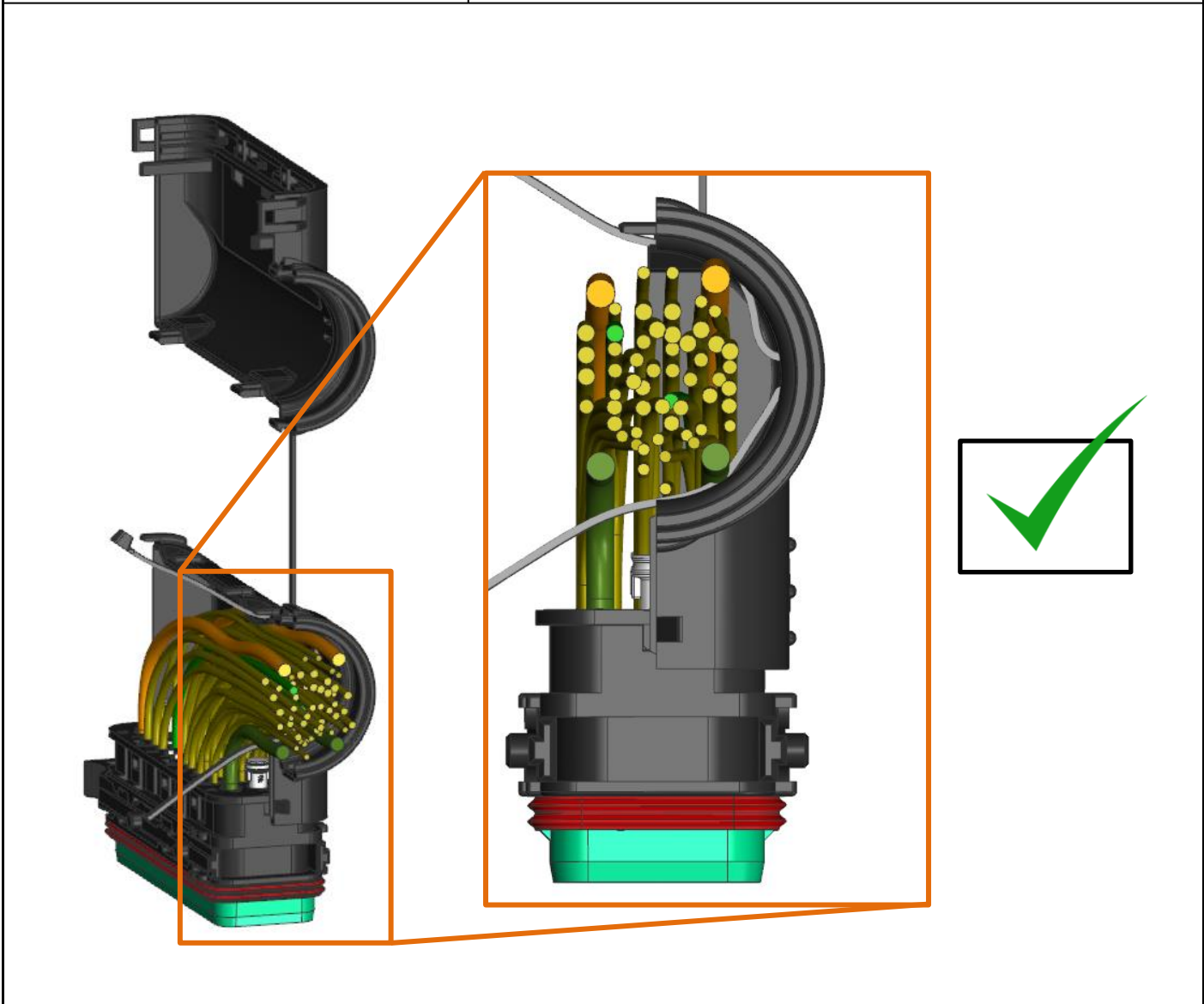
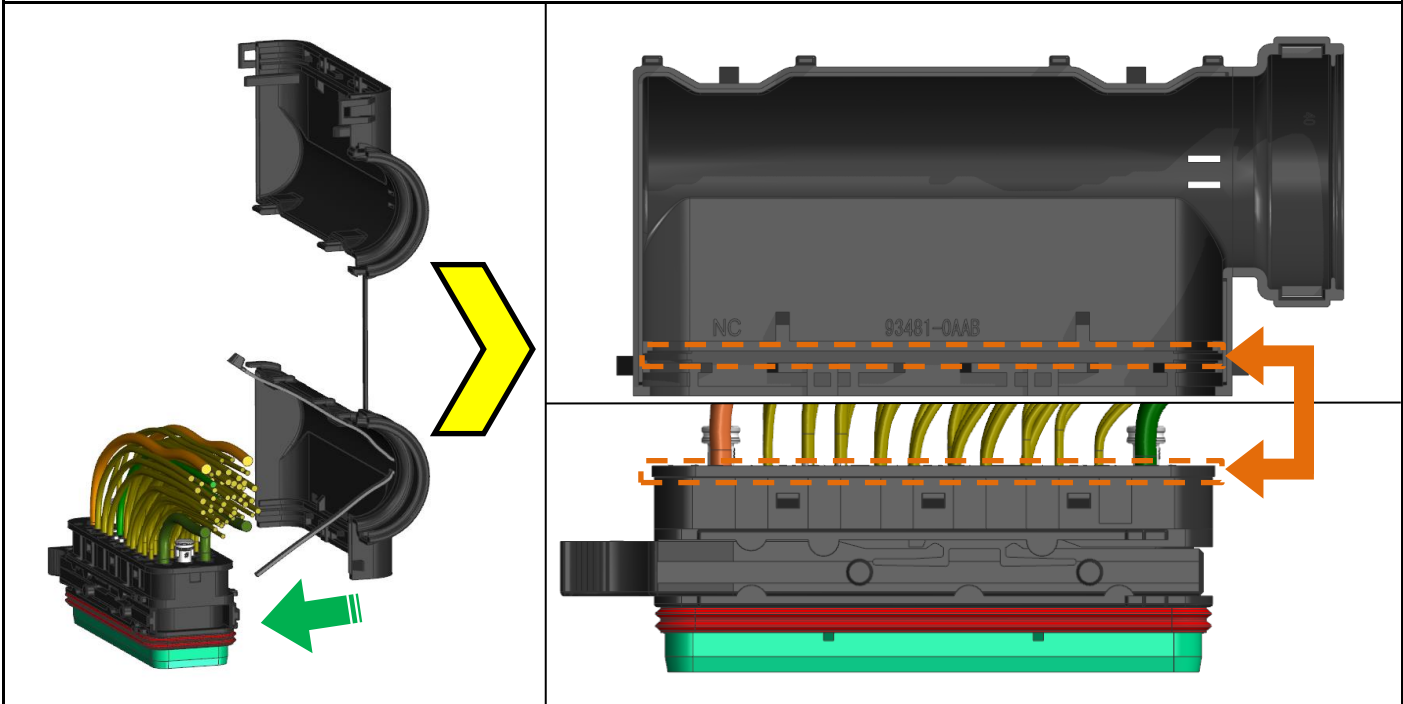

# Recommended assembly sequence

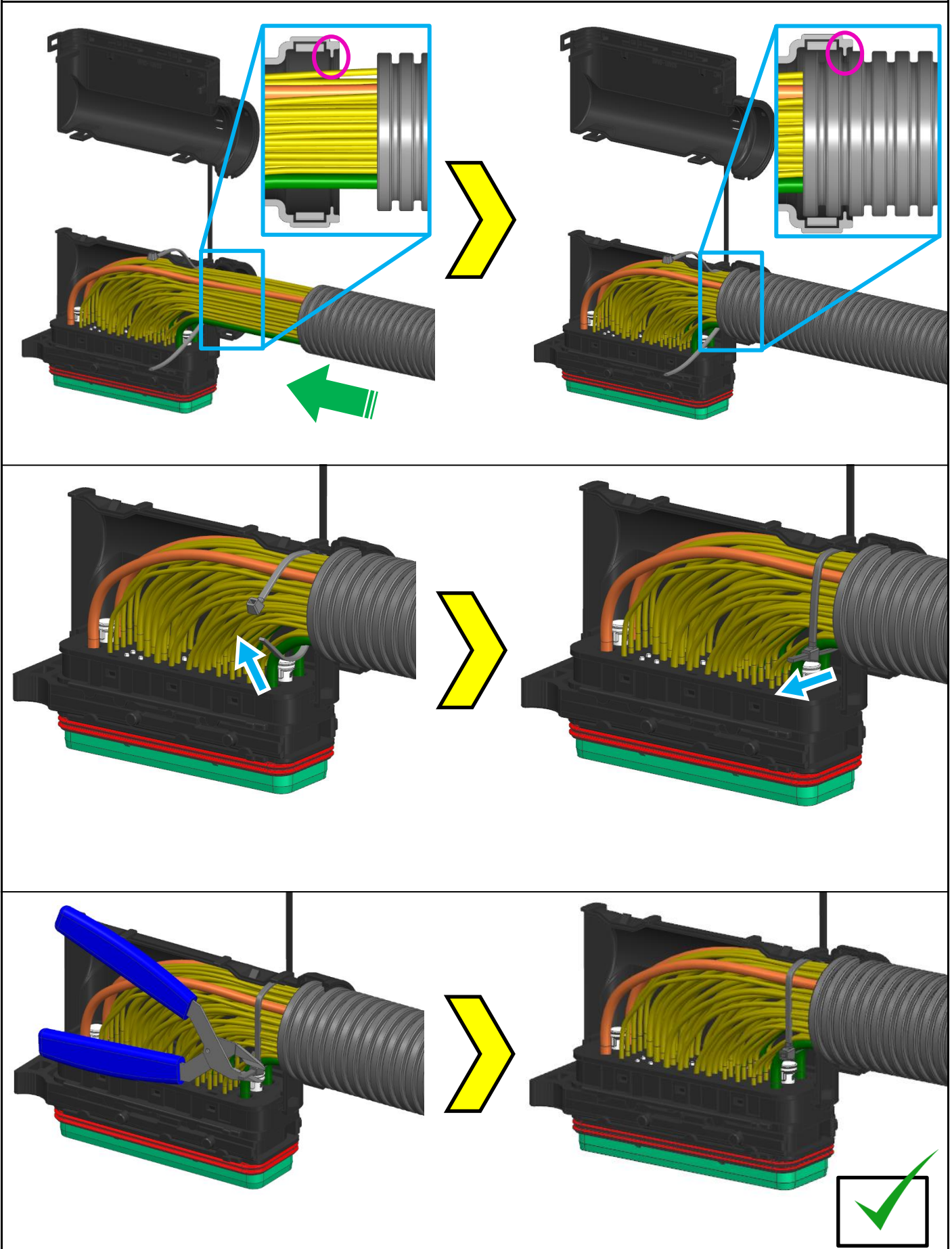

# Recommended assembly sequence

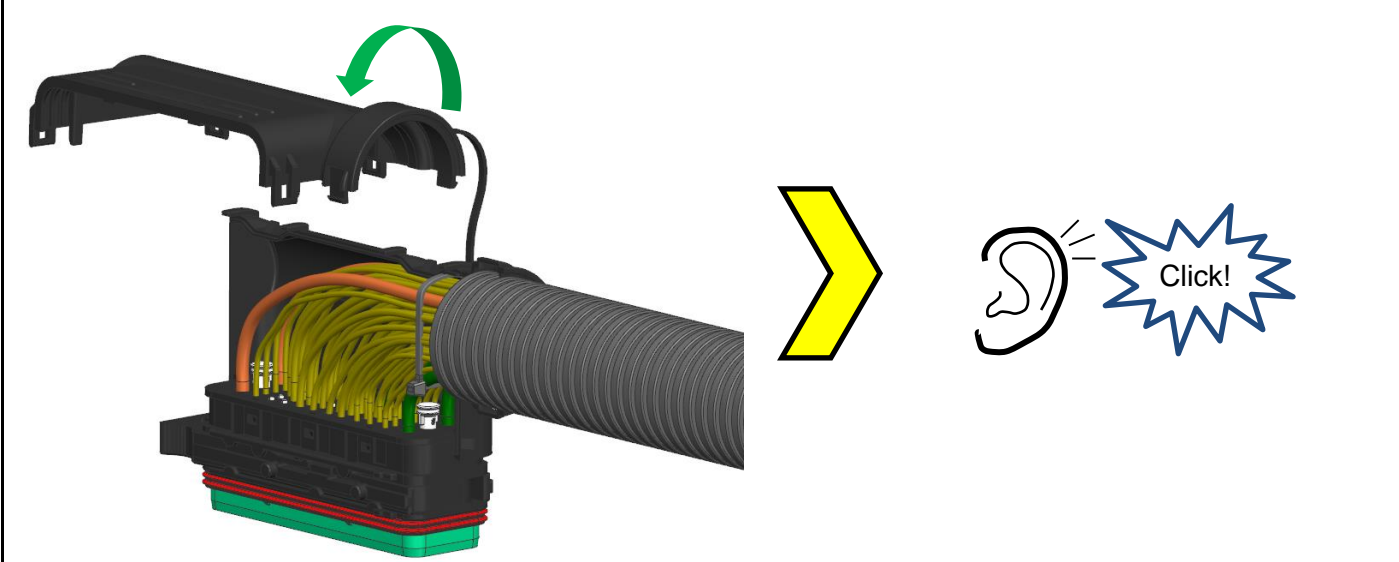

OR

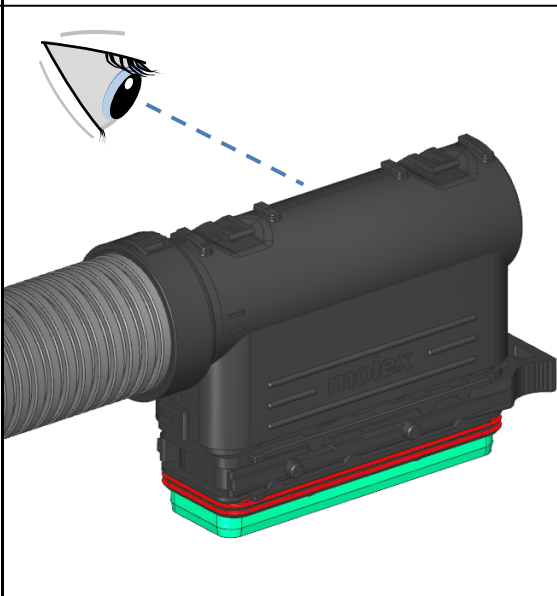
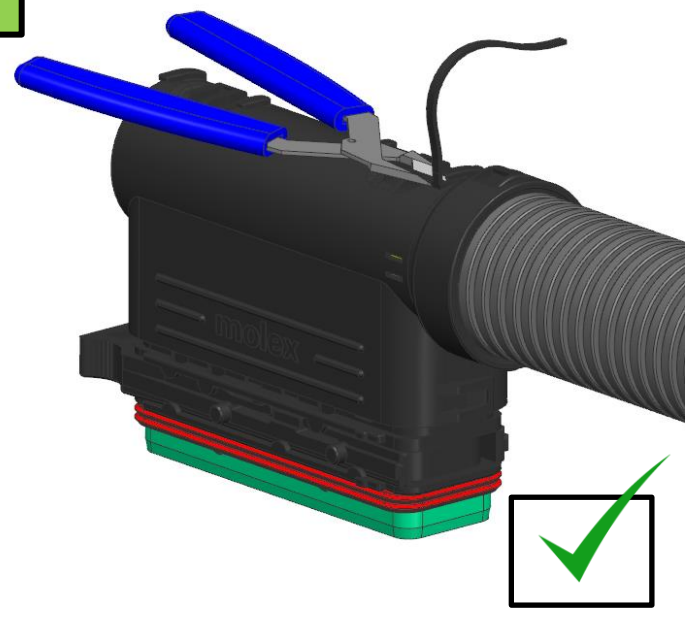
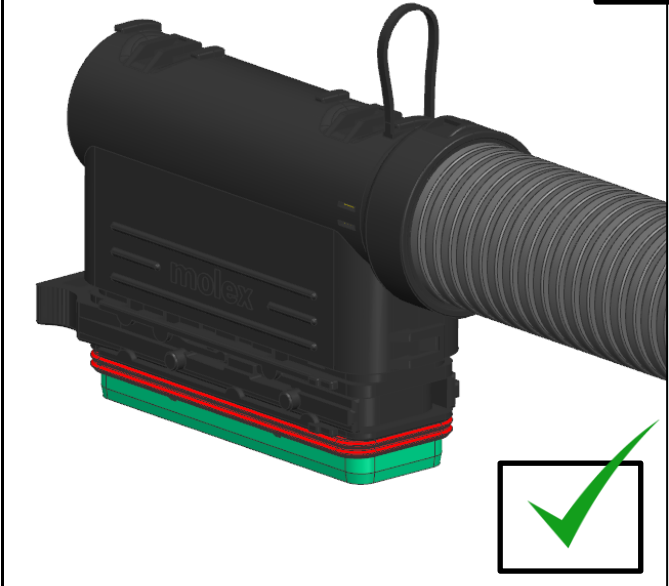

# Male assembly overview

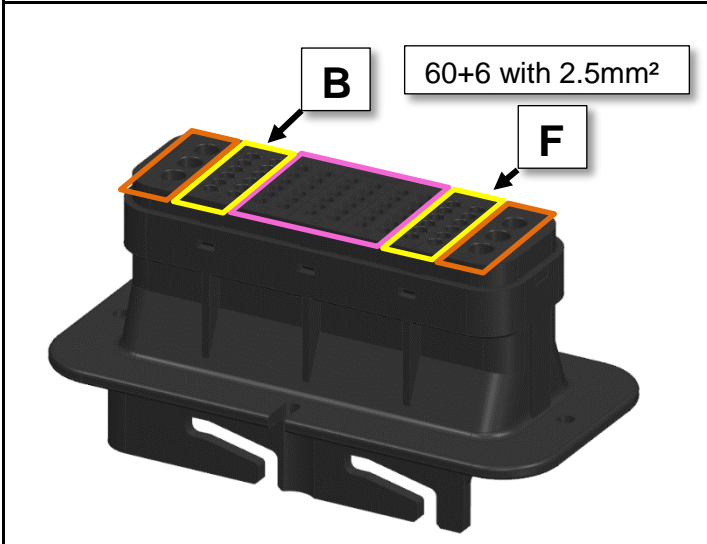

- 2.5mm<sup>2</sup> only available on some configurations and only in **B and F** locations as highlighted in yellow above
  - For all configurations please see 937921000 PSD

## Signal

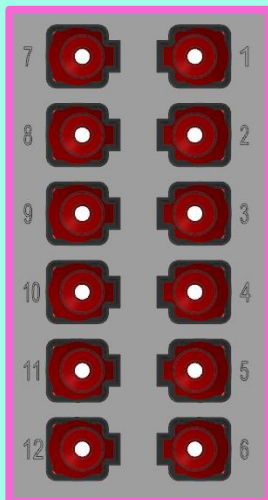

**Signal**  
Cable Insulation  
Diameter Range  
1.5 - 2.7mm

## 2.5mm<sup>2</sup>

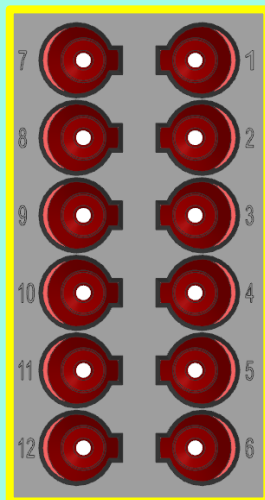

**2.5mm<sup>2</sup>**  
Cable Insulation  
Diameter Range  
1.5 – 3.0mm

## Power

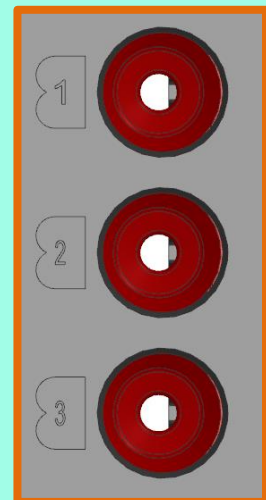

**Power**  
Cable Insulation  
Diameter Range  
3.0 – 5.0mm

# Step 1 – open TPA

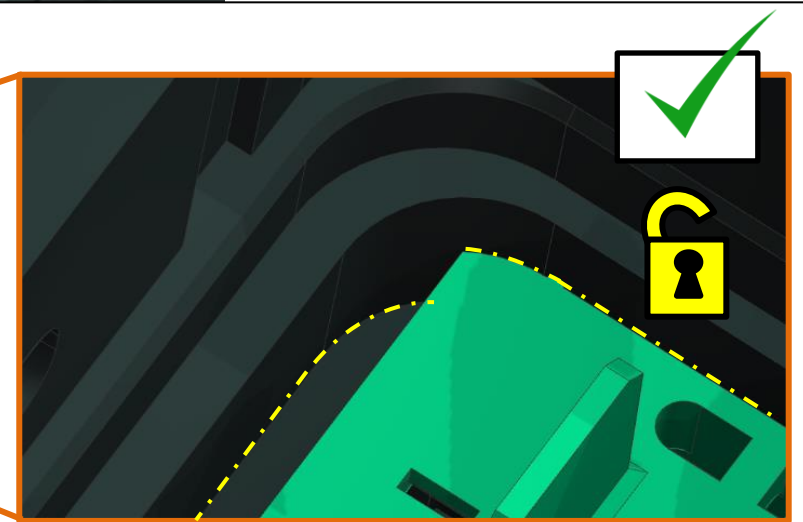
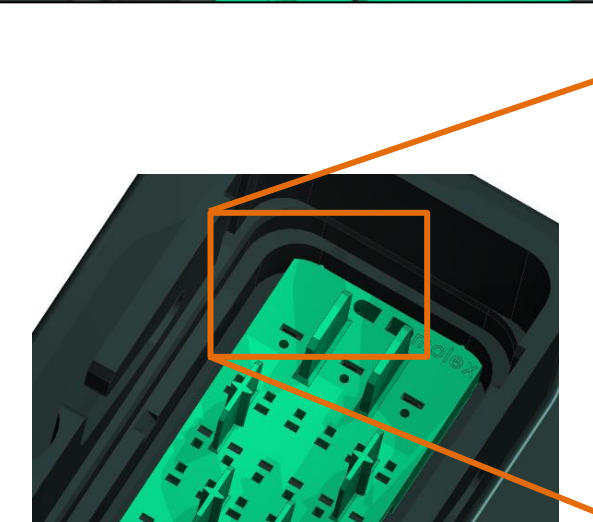
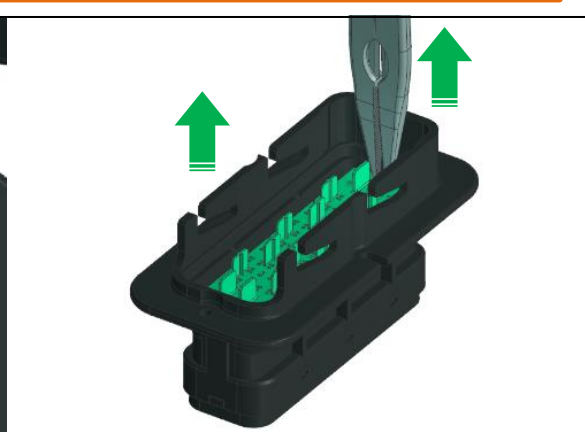
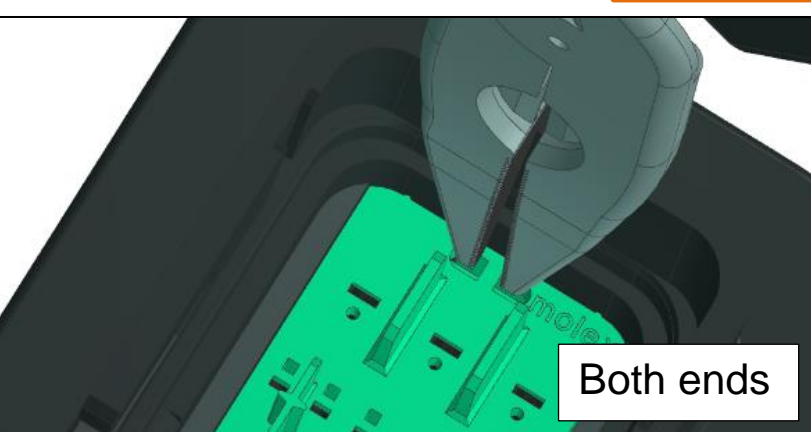
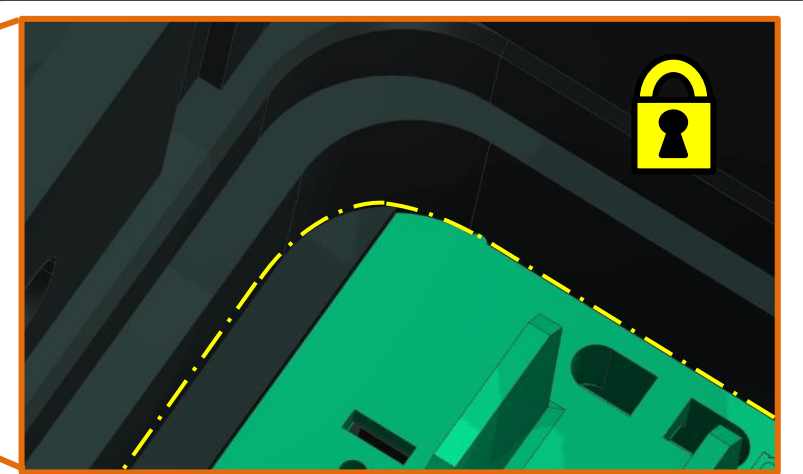
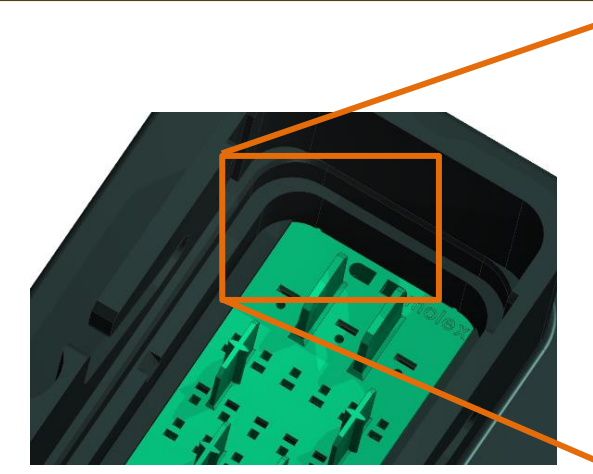
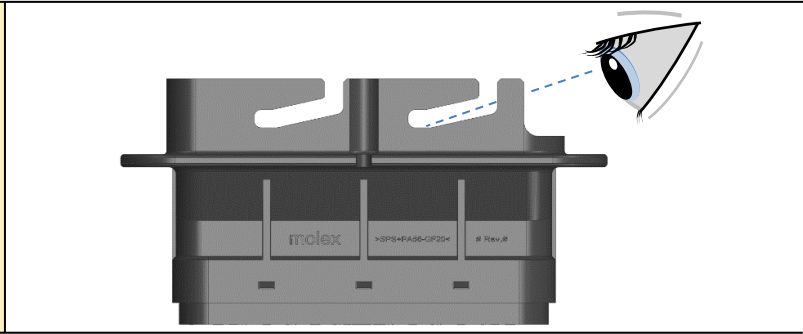
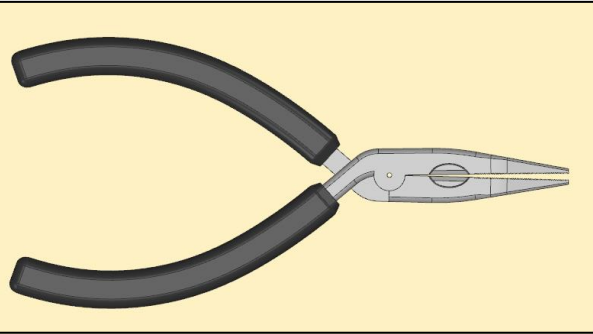

## Step 2 – insert signal blind cavity plugs

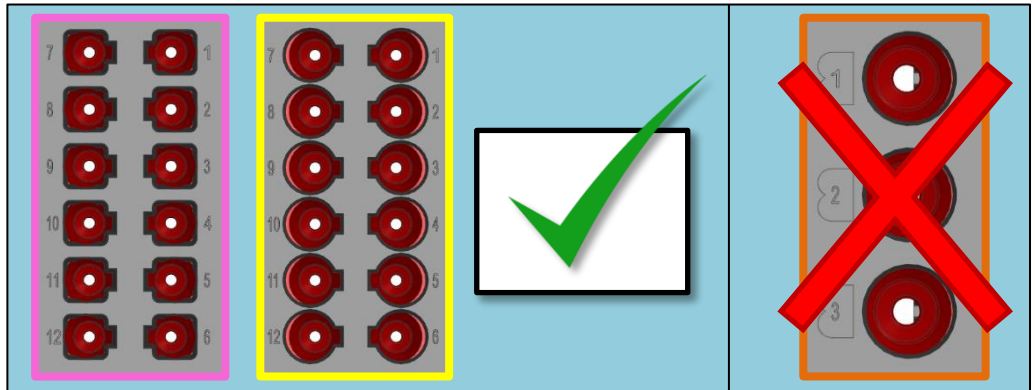
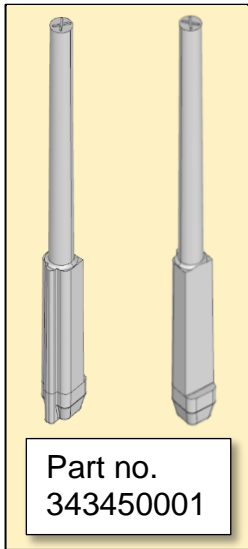

**Demonstration example**

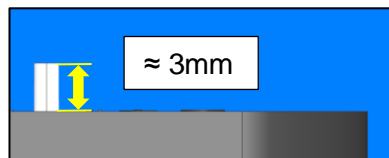
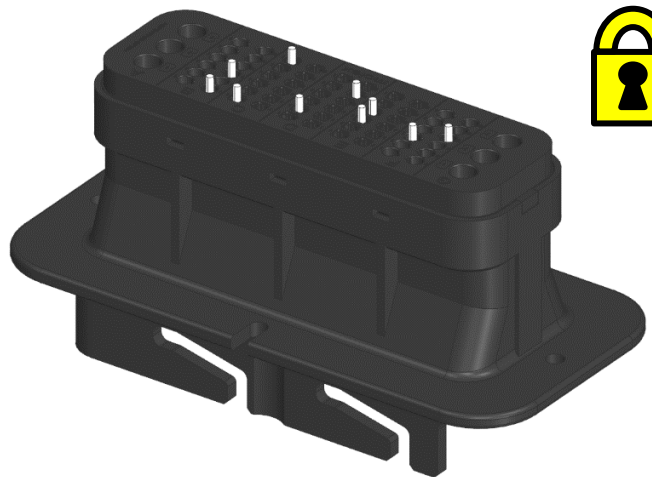
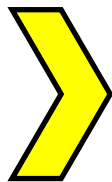
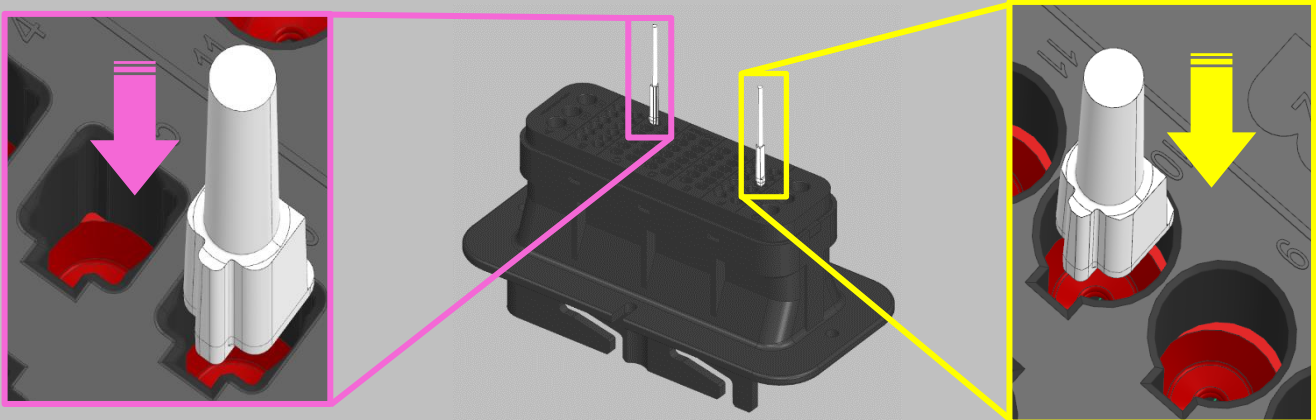

## Step 2.1 – trim signal blind cavity plugs (recommended)

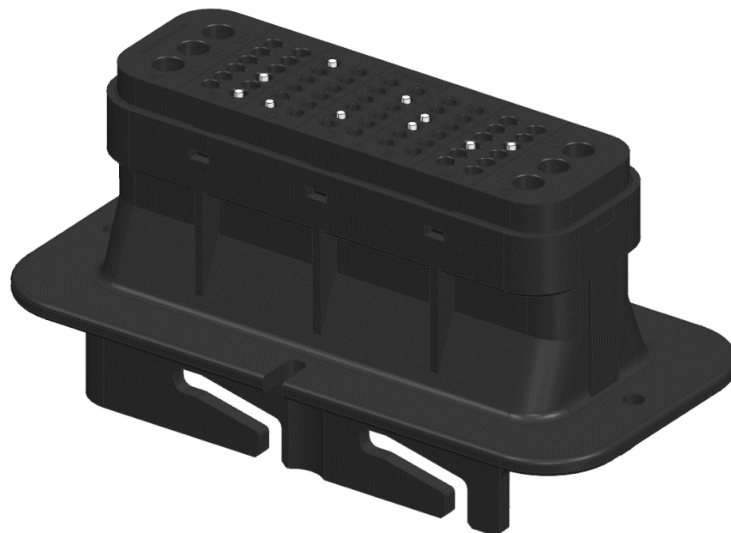
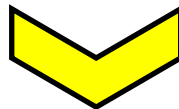
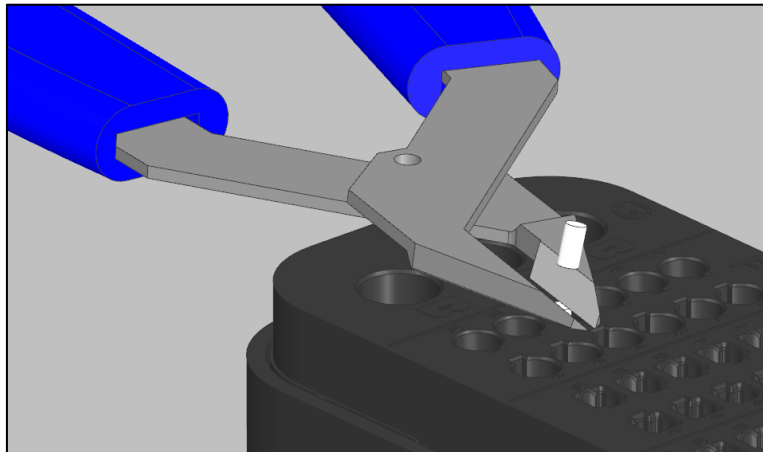
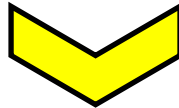
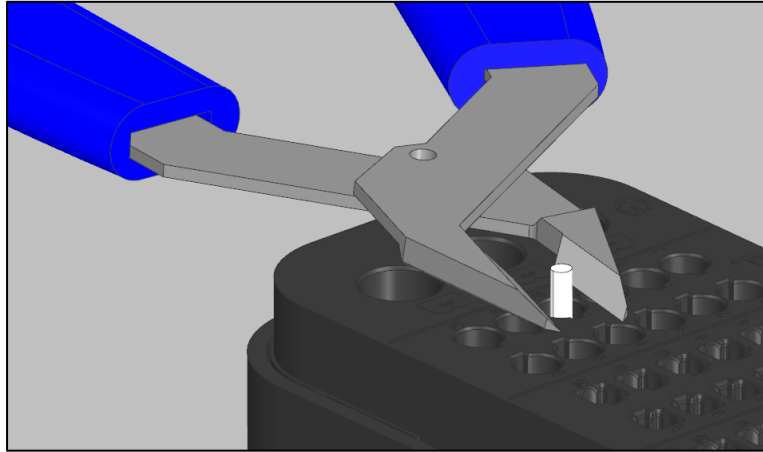
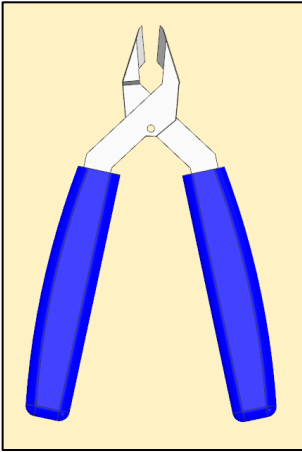

**Demonstration example**



# Step 3 – insert power blind cavity plugs

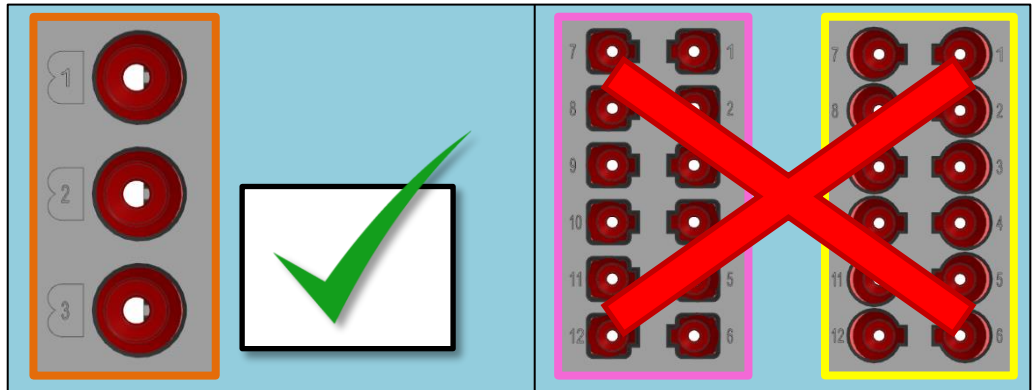
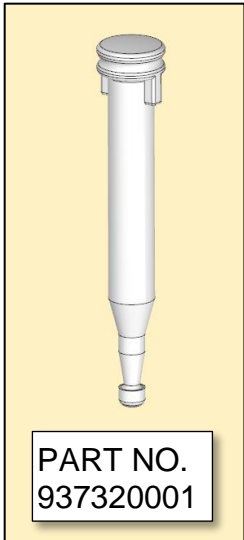

**Demonstration example**

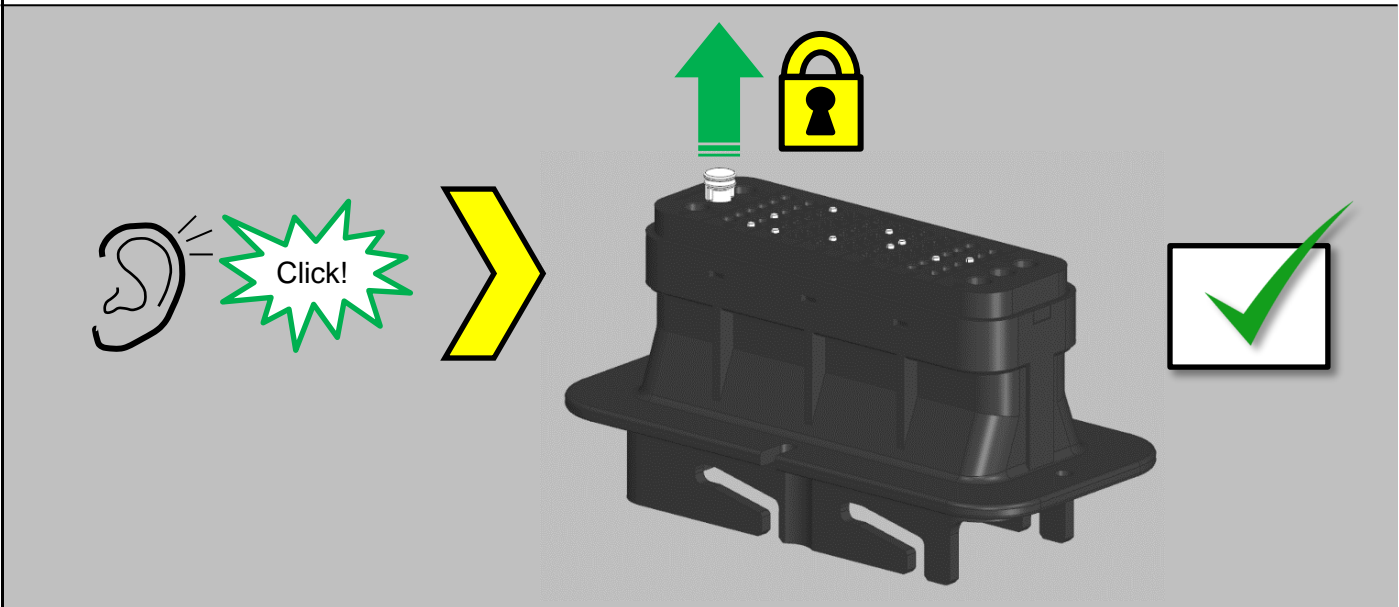
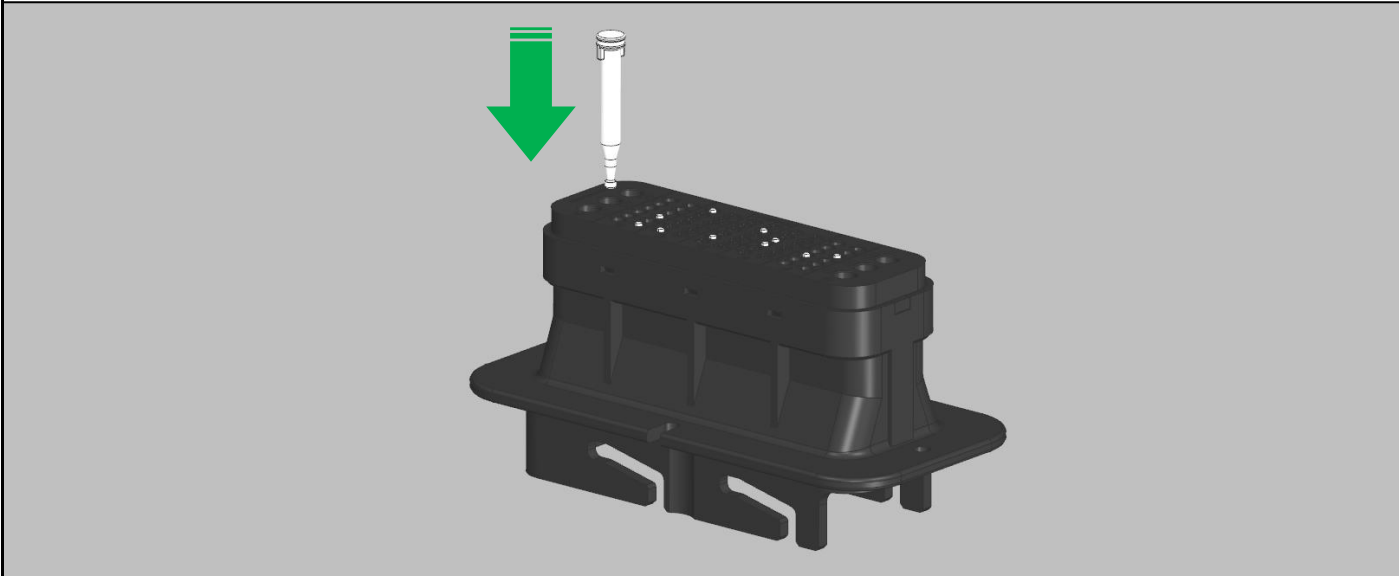

## Step 4 – insert signal terminals

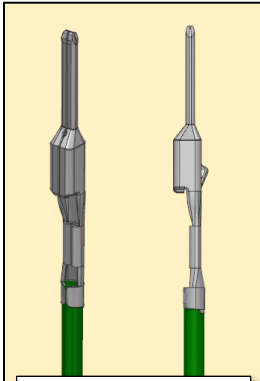

Part no. see sales drawing SD-33000-001

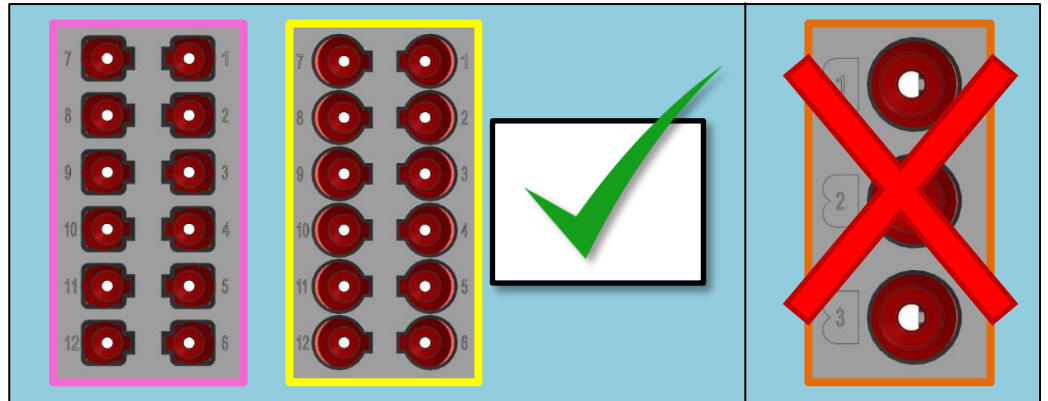

### Important:

- Hold cable while putting in male terminals
- Insert terminals 90° to the rear cover
- Insert terminal nose carefully through seal opening

#### Signal

Cable Insulation Diameter  
Range 1.5 - 2.7mm

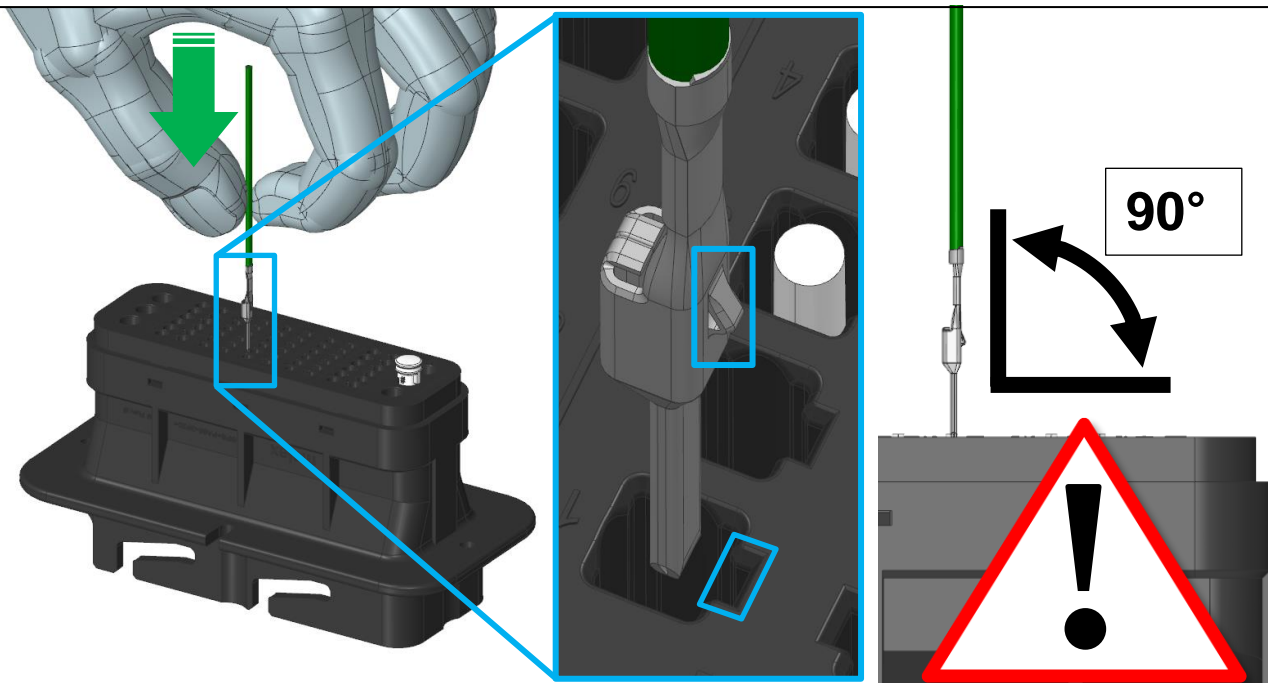

### Demonstration example

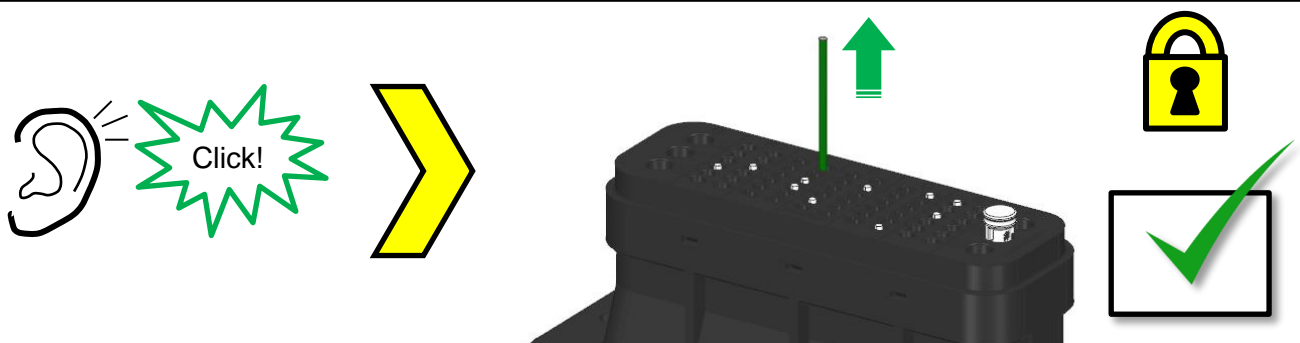

REVISION:  
**C1**

DOCUMENT NUMBER:  
**850830010 PSA**

SHEET No.  
**26 of 52**

## Step 5 – insert 2.5mm<sup>2</sup> terminals

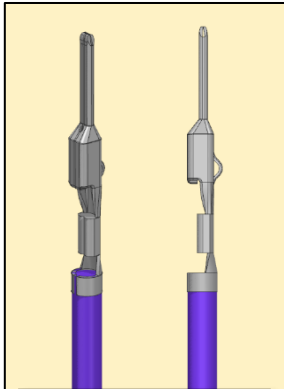

Part no. see  
sales drawing  
936420010 PSD

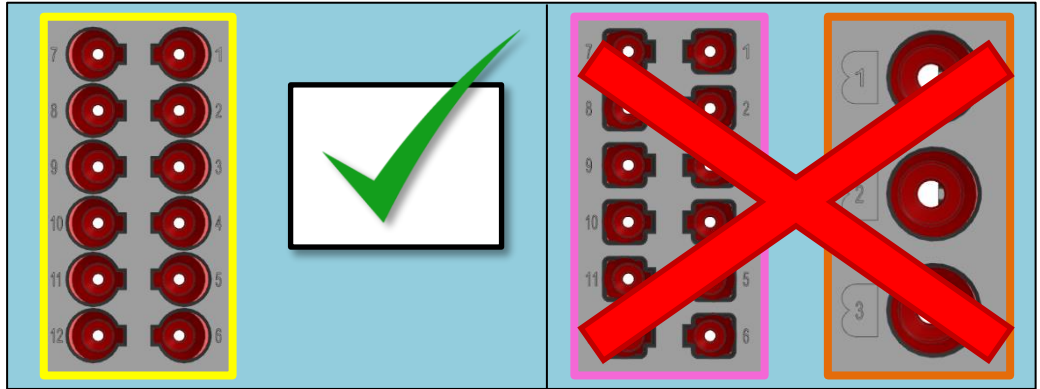

**2.5mm<sup>2</sup>**  
Cable Insulation Diameter  
Range 1.5 – 3.0mm

### Important:

- Hold cable while putting in male terminals
- Insert terminals 90° to the rear cover
- Insert terminal nose carefully through seal opening

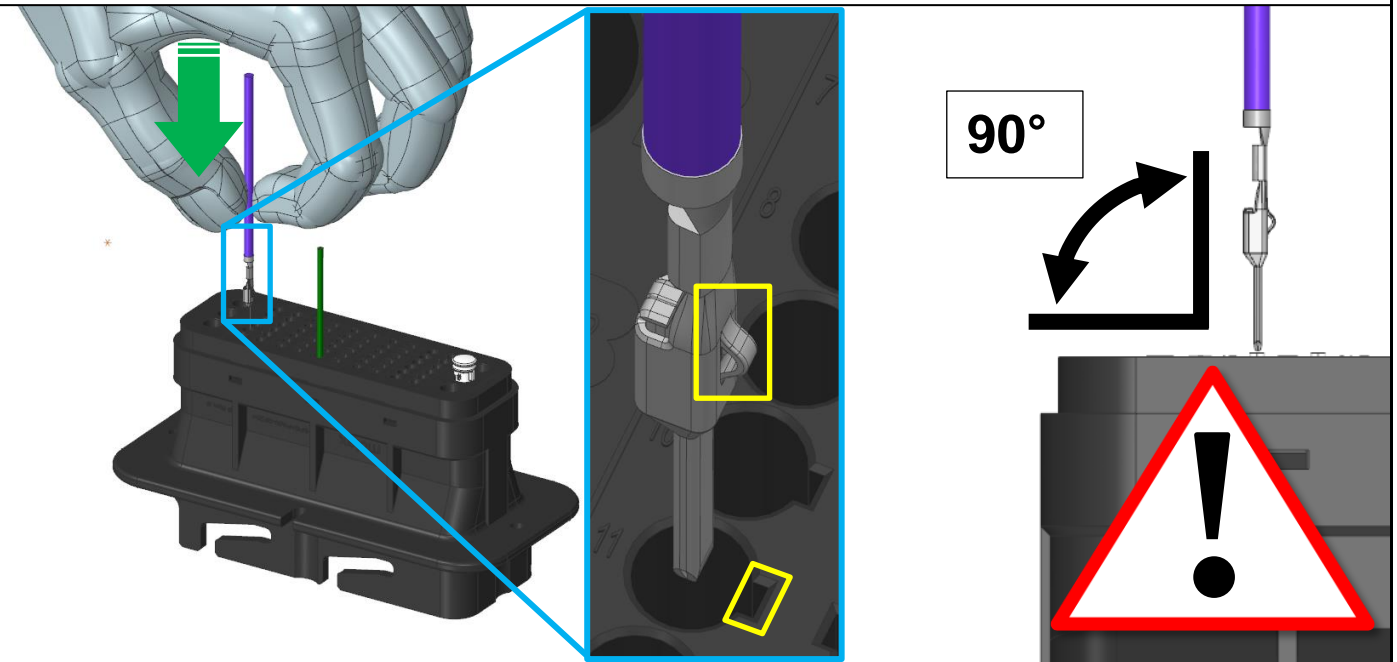

### Demonstration example

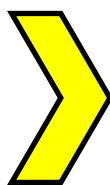

# Step 6 – insert power terminals

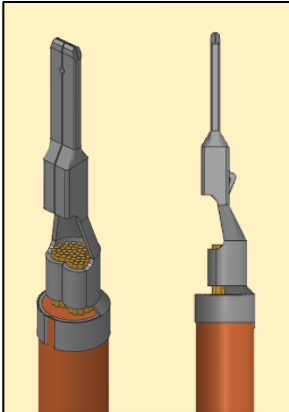

Part no. see sales drawing SD-19431-00\*

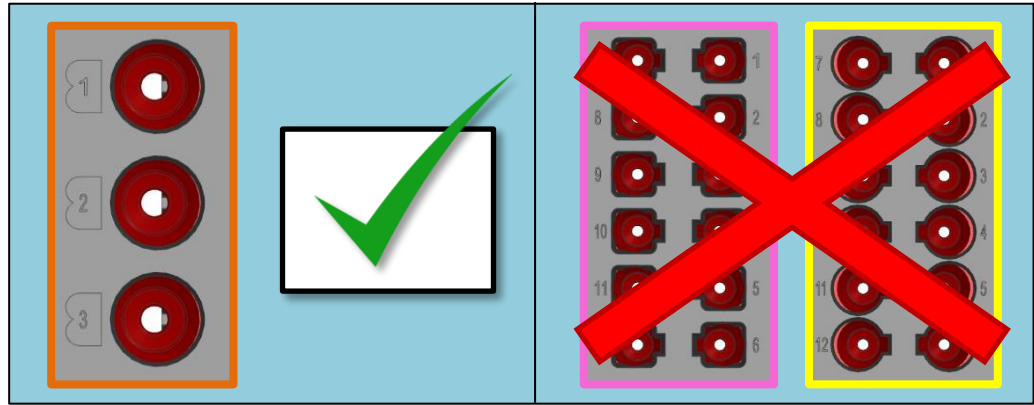

**Power**  
Cable Insulation Diameter Range 3.0 – 5.0mm

**Important:**

- Hold cable while putting in male terminals
- Insert terminals 90° to the rear cover
- Insert terminal nose carefully through seal opening

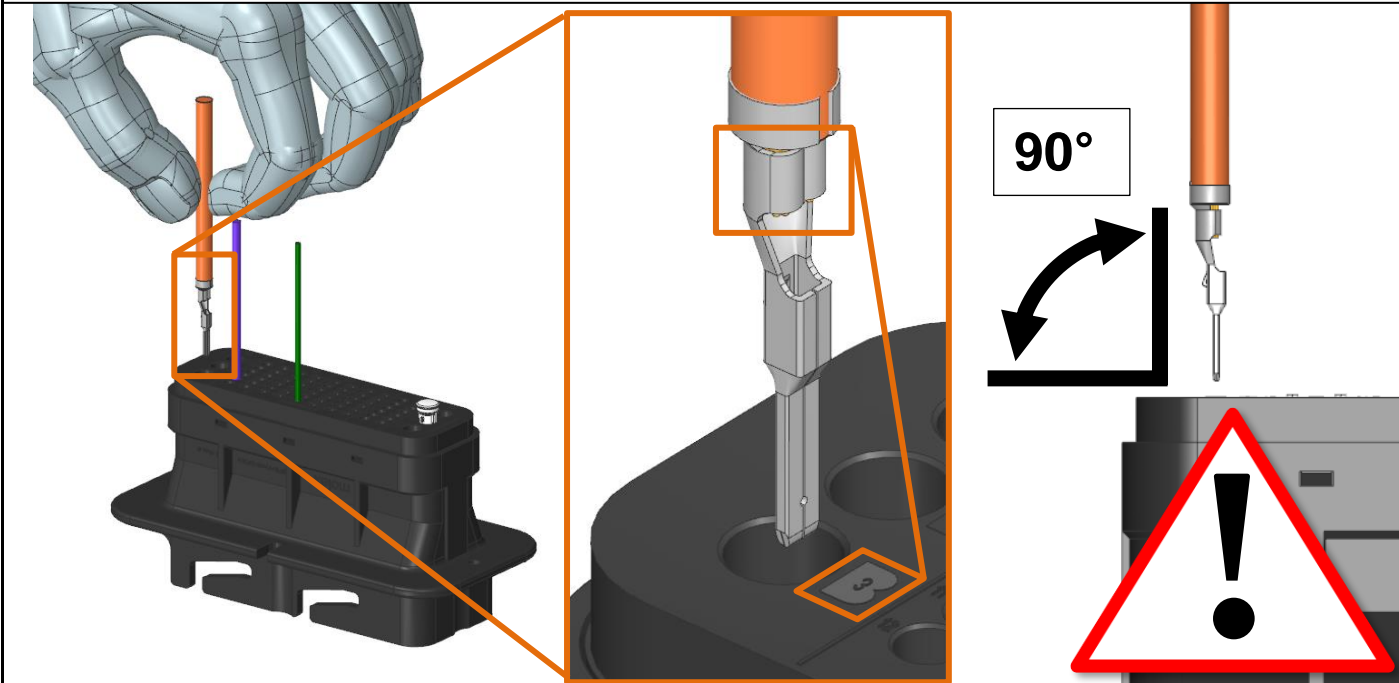

## Demonstration example

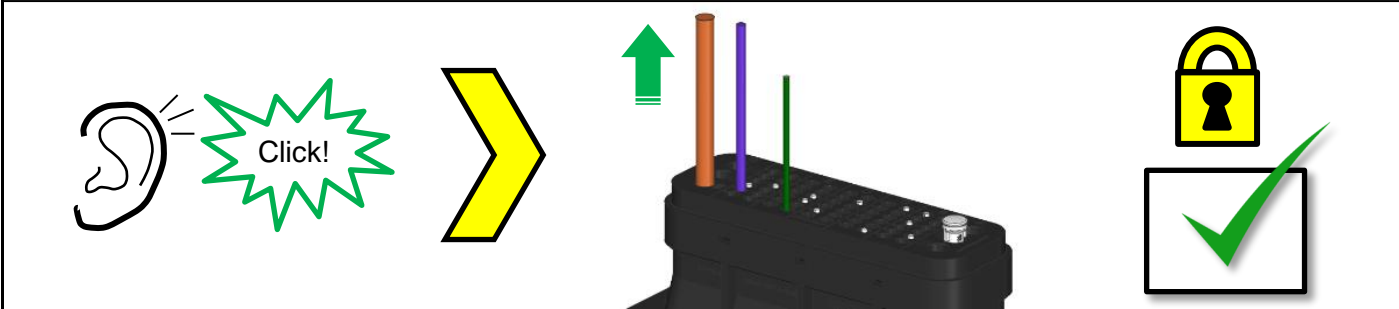

## Step 7 – close TPA



**Populate connector fully  
No holes left empty**

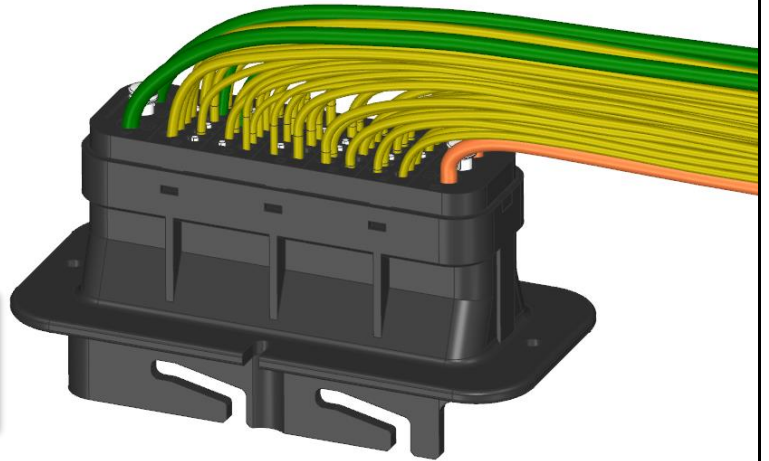

**Final Check**

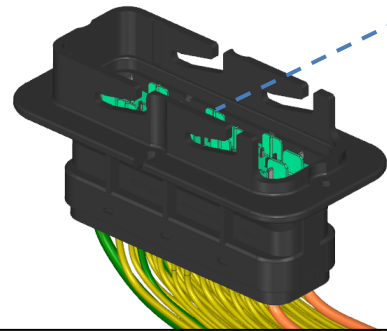
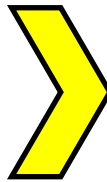
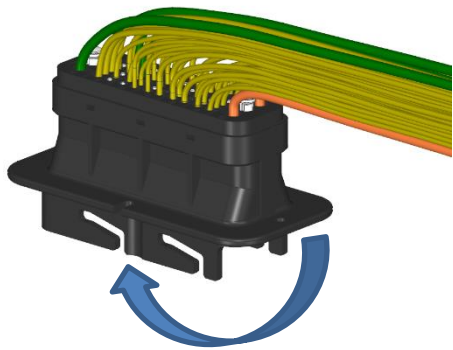

**Note:** Where terminals are not shown, blind cavity plugs have been used

**Demonstration example**



**Ensure all cables are pushed forward fully**

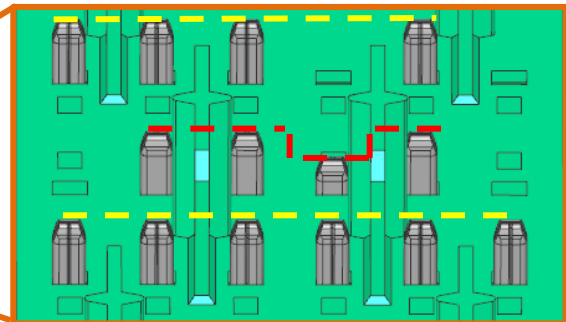
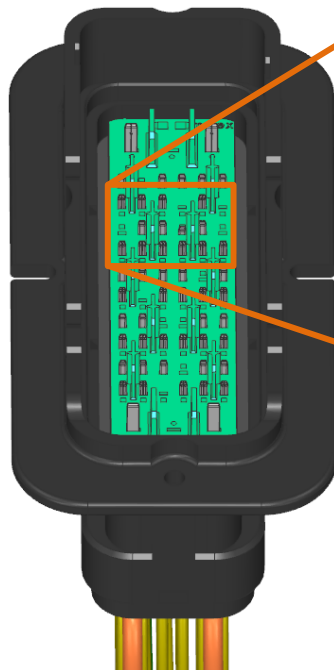

## Step 7 – close TPA

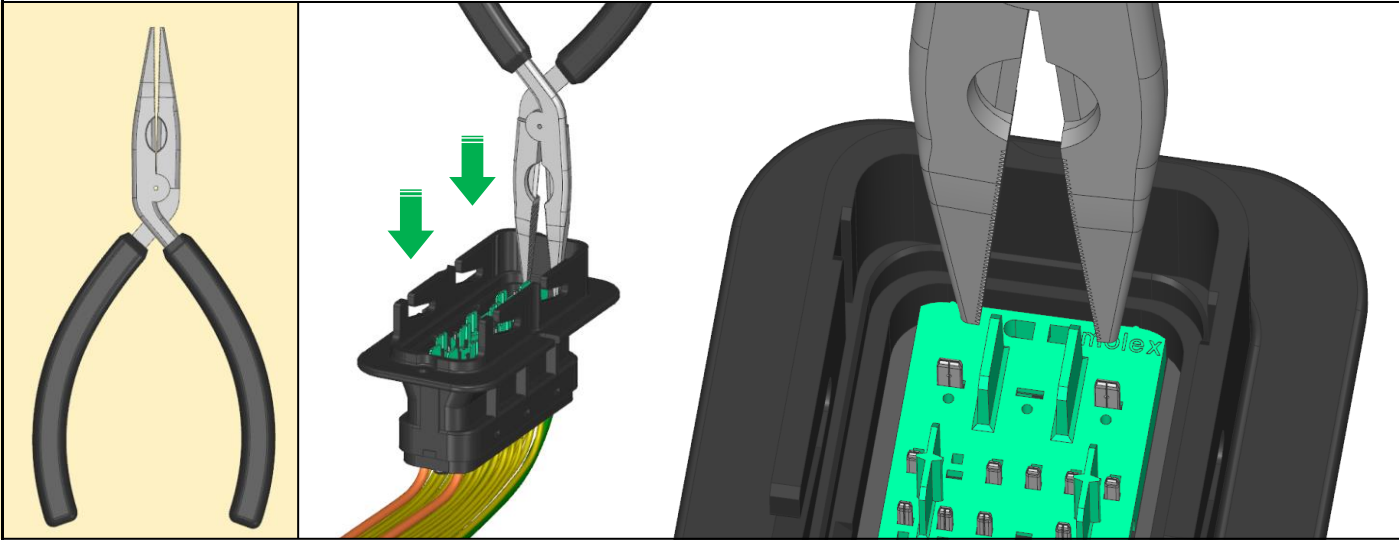

**Note:** Where terminals are not shown, blind cavity plugs have been used

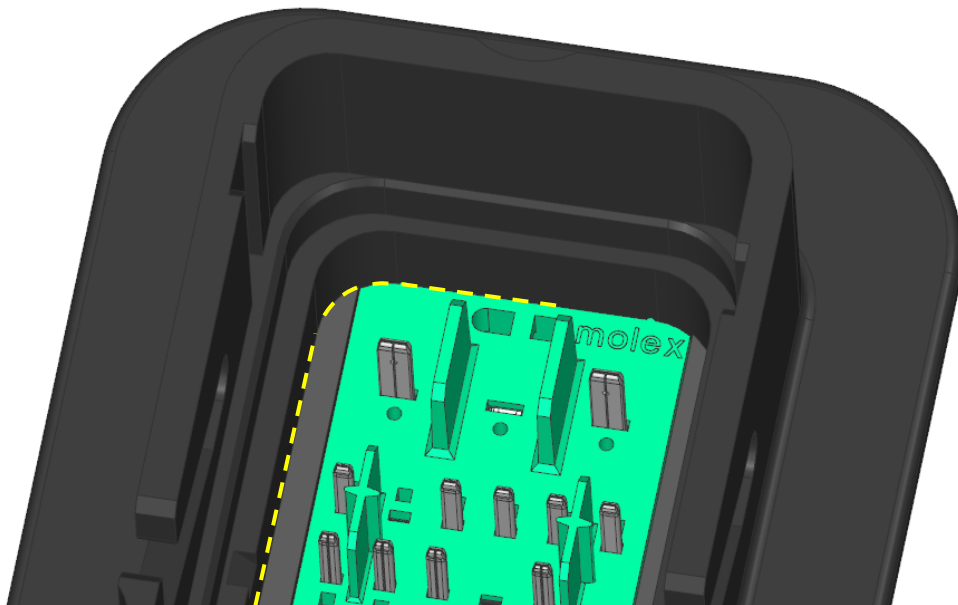

## Step 8 – apply wire dress/conduit interface



- Various configurations of wire dress available.
  - 1 – 3 open exits
  - 4 different exit sizes
- See sales drawing: 934811000 PSD
- Appropriate conduit must be used with wire dress
- Example shown for demonstration only
- Direction of exit(s) per wiring diagram

### Tool & parts needed

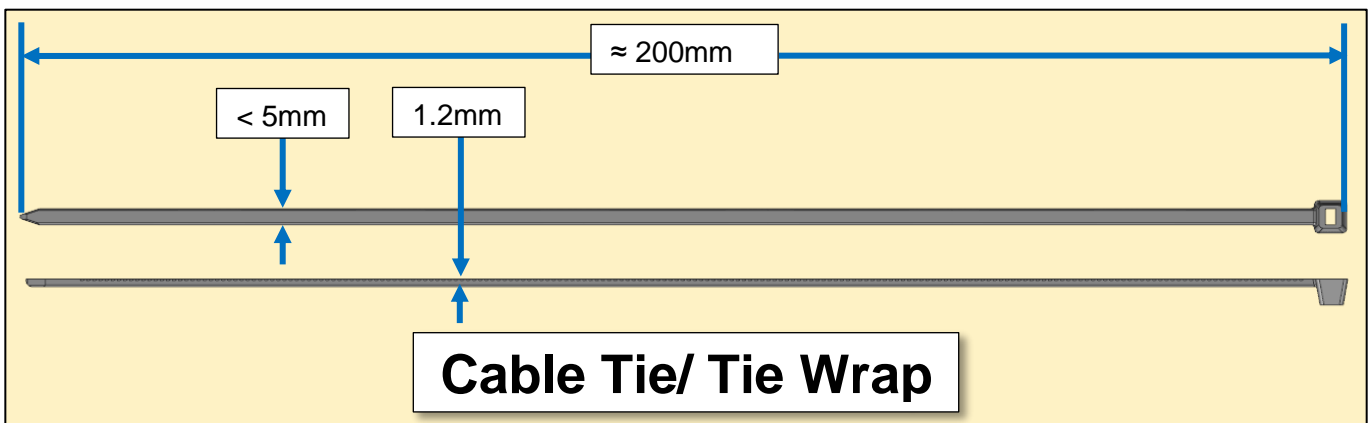
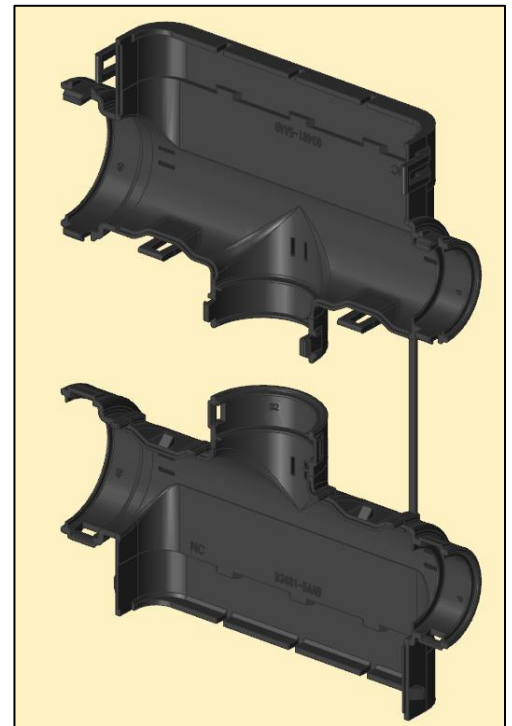
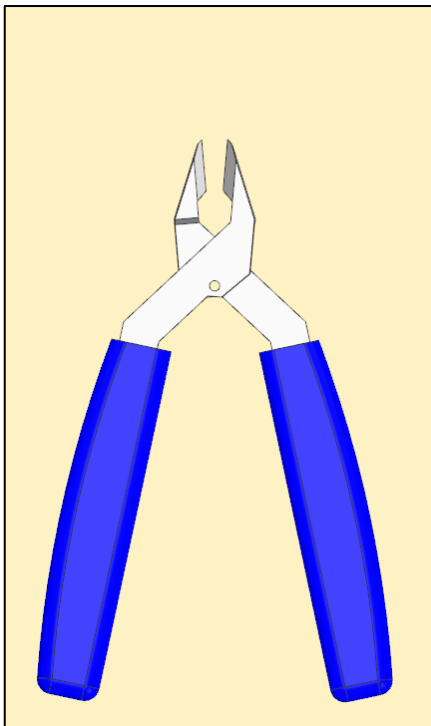

# Recommended assembly sequence

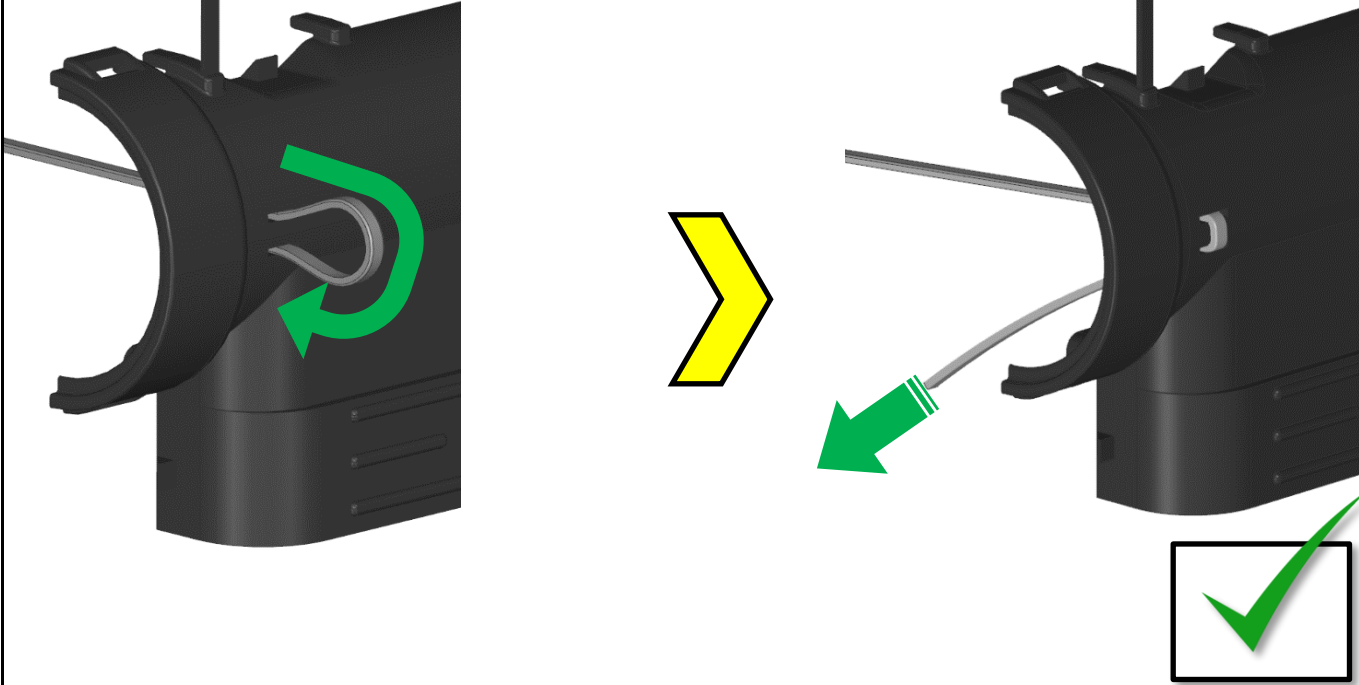
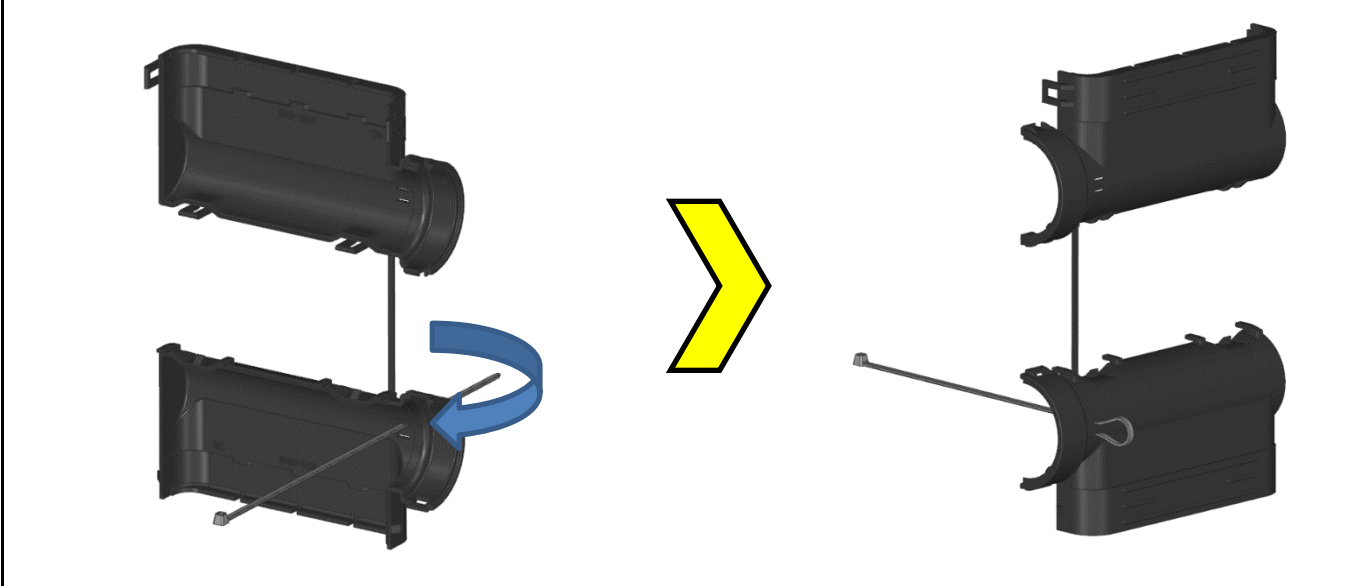
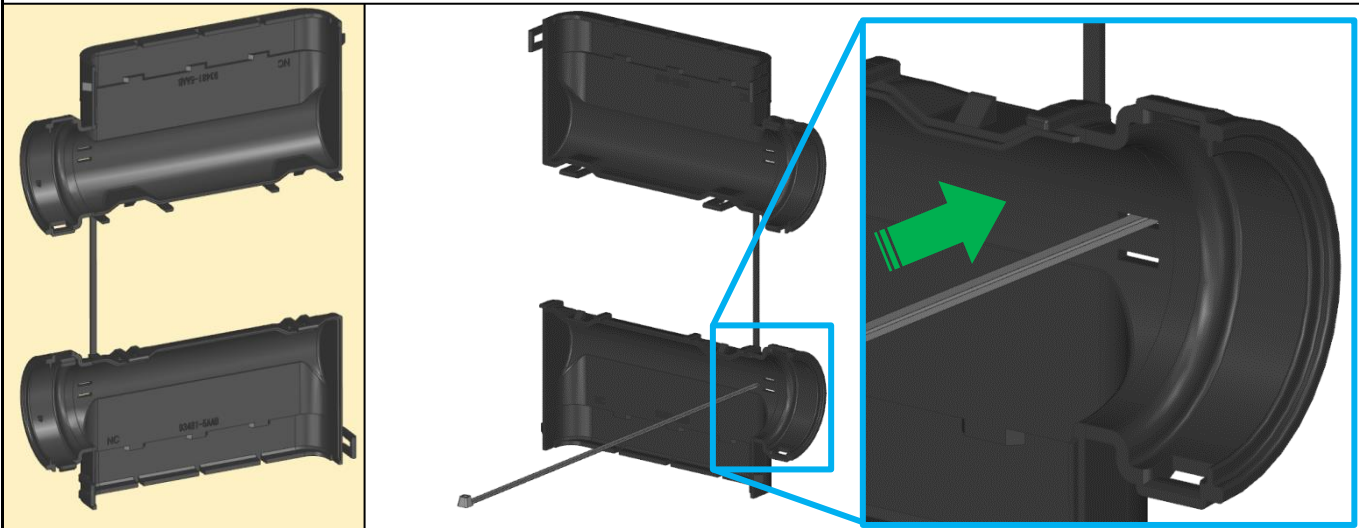



# Recommended assembly sequence

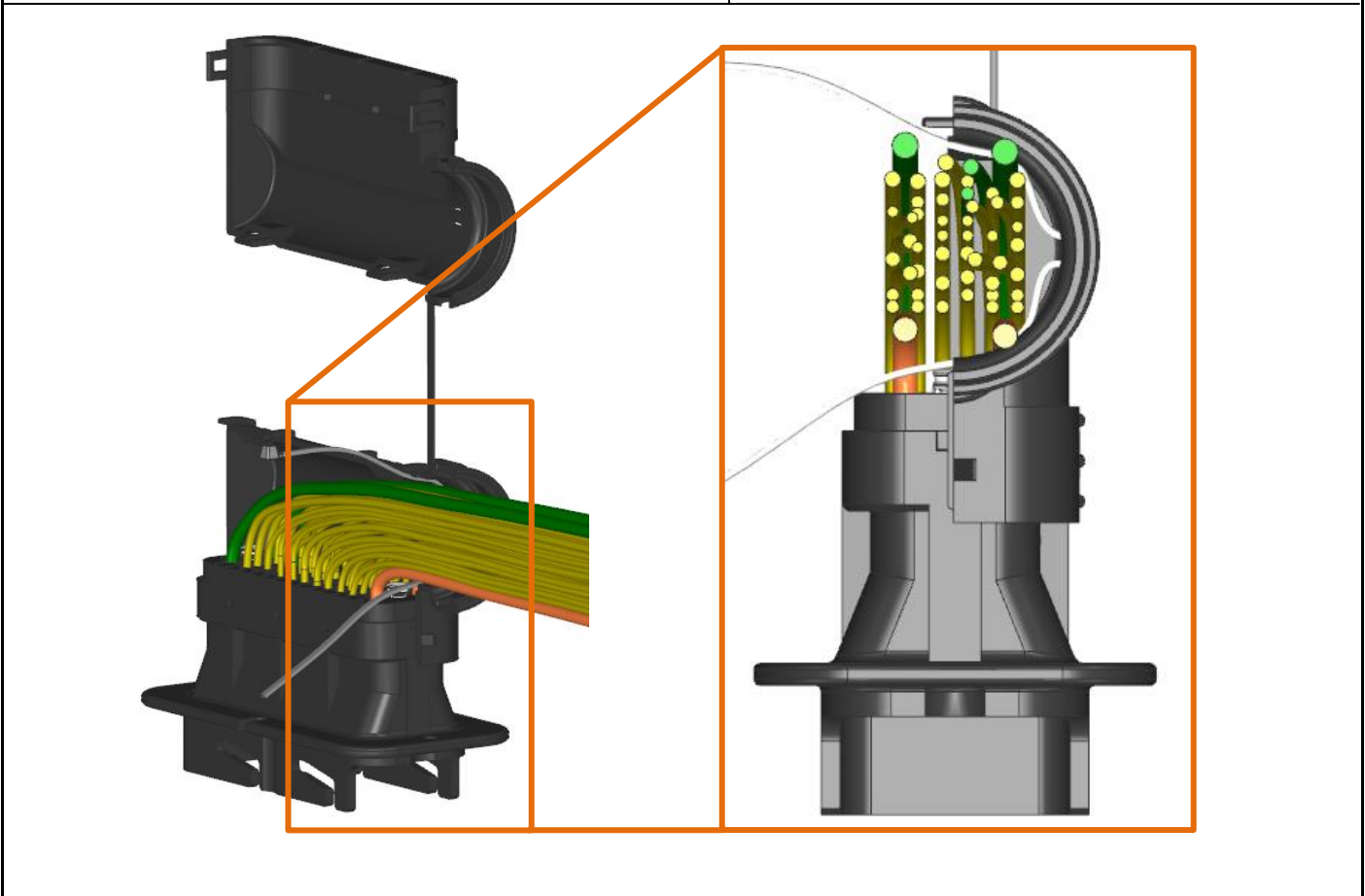
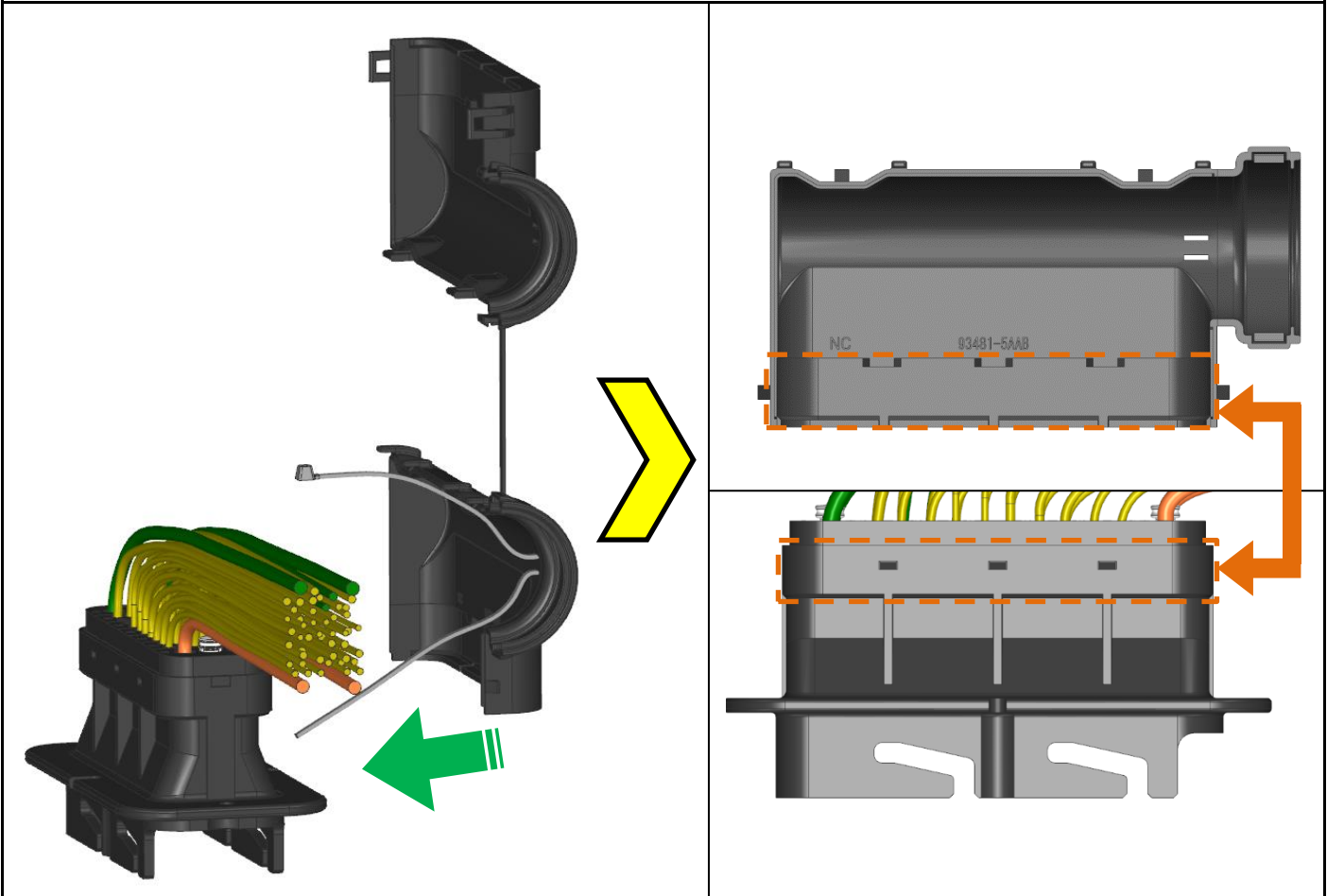

REVISION:  
**C1**

DOCUMENT NUMBER:  
**850830010 PSA**

SHEET No.  
**33 of 52**

# Recommended assembly sequence

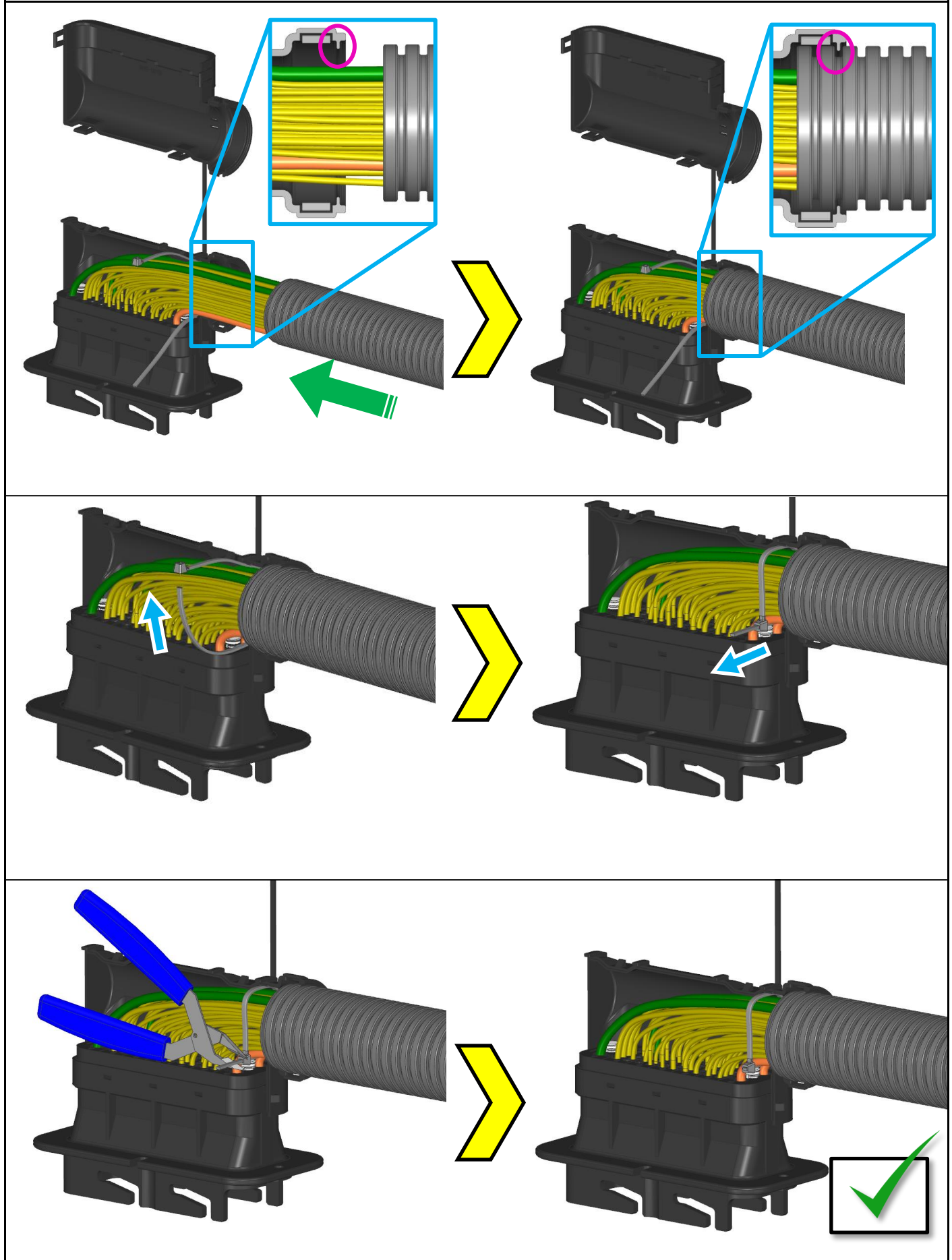

# Recommended assembly sequence

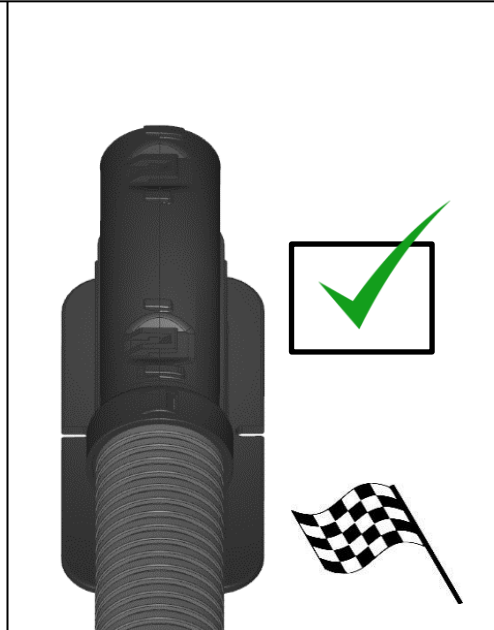
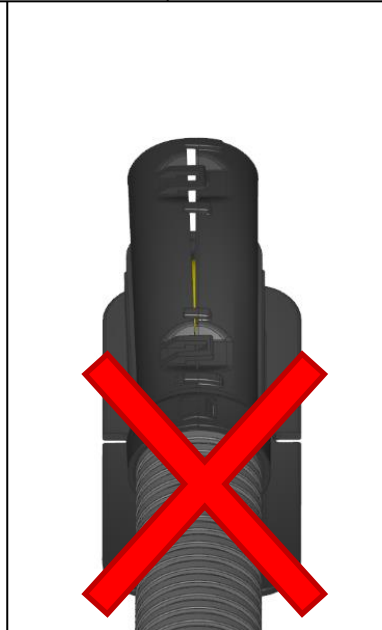
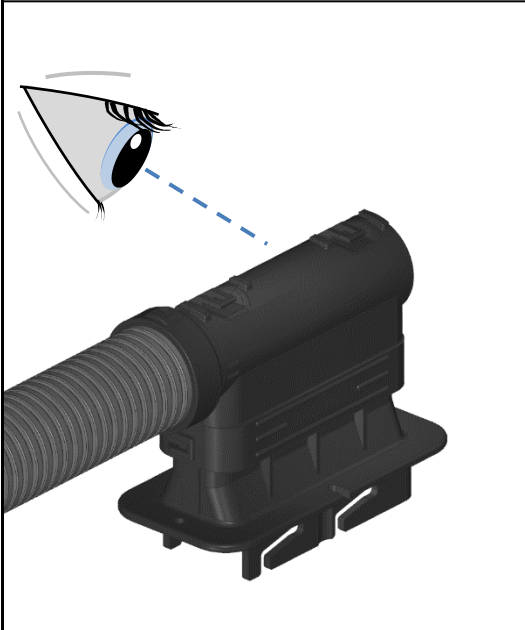
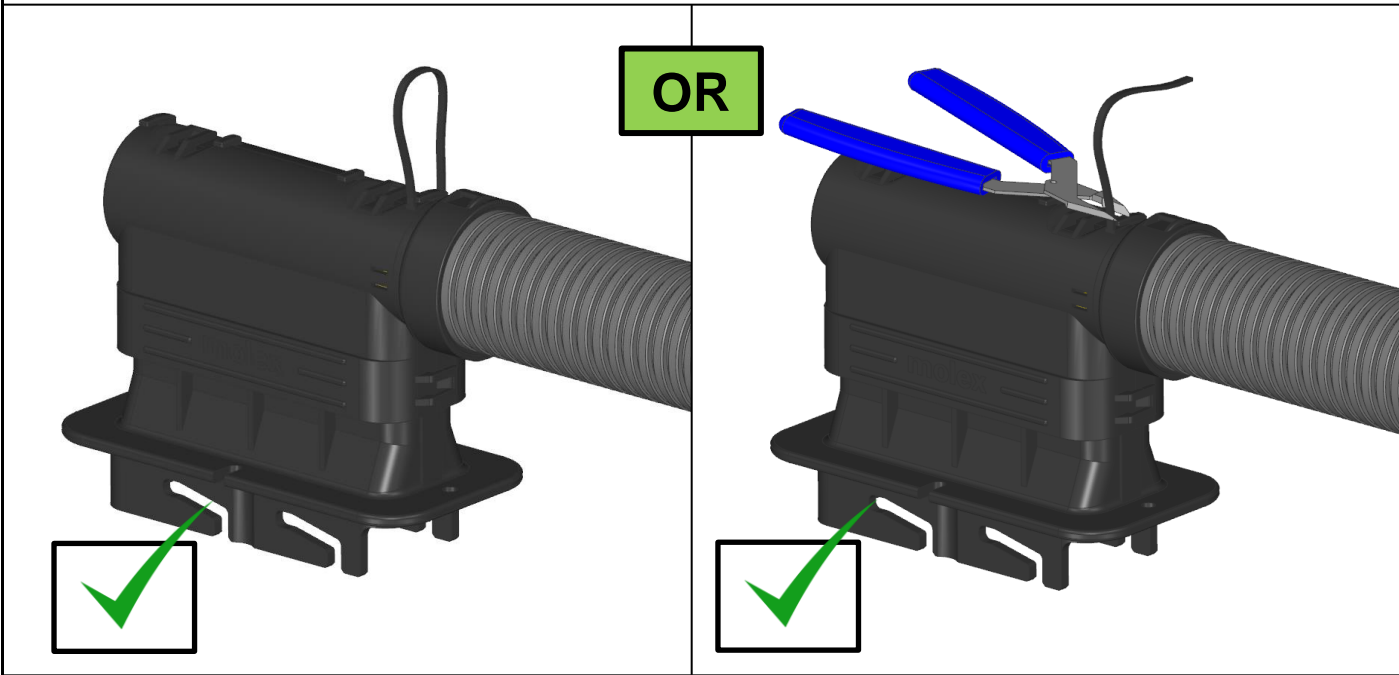
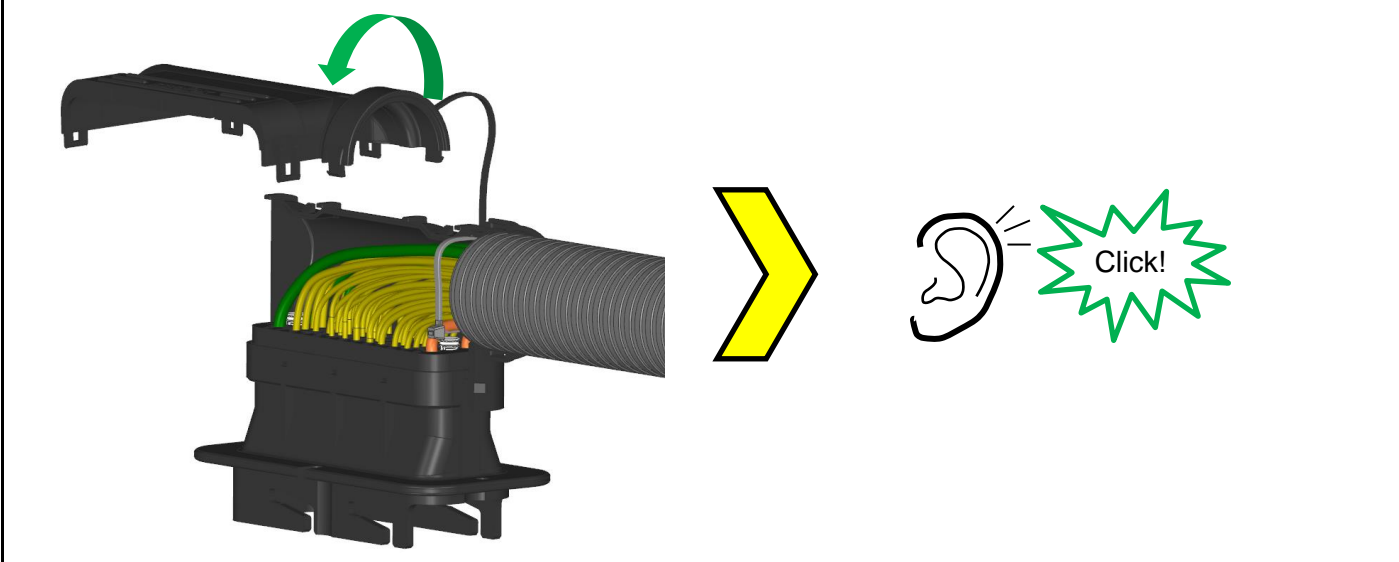

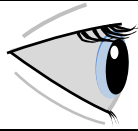

## Recommended checks

Female TPA is closed

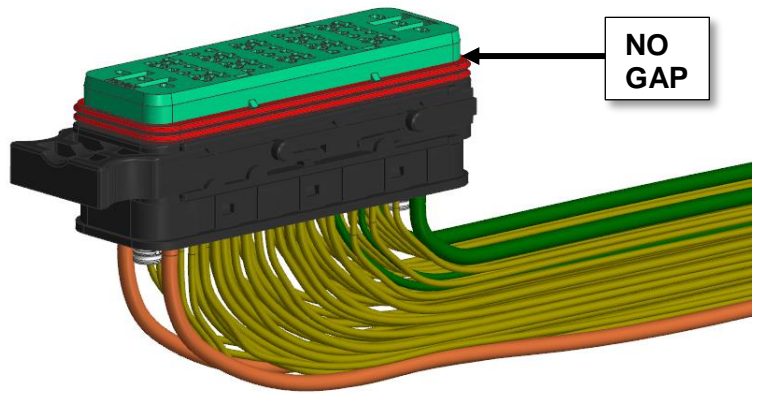

Male TPA is closed

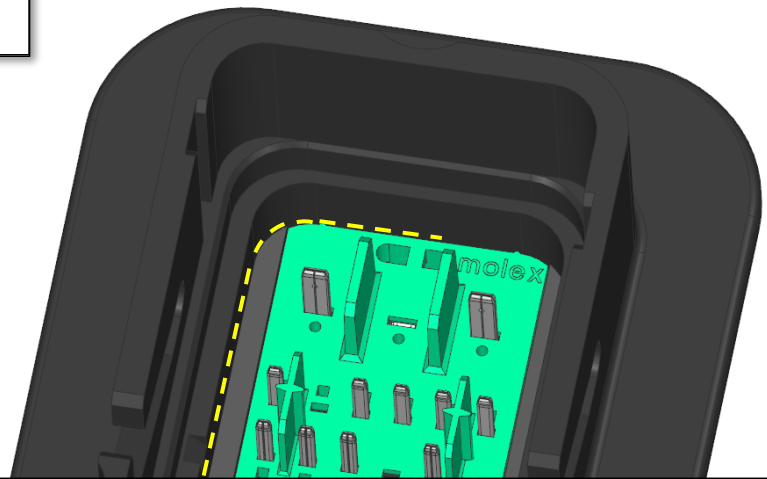

Check for front seal roll

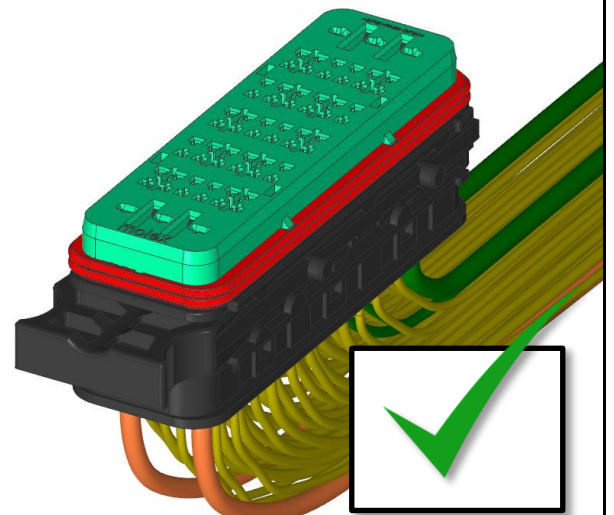
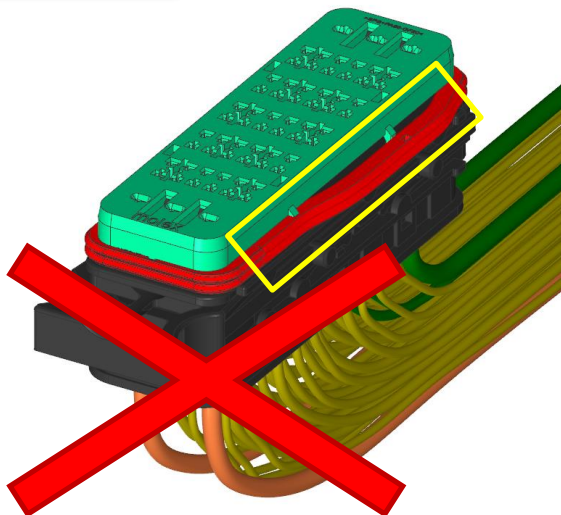

# Mating the connectors

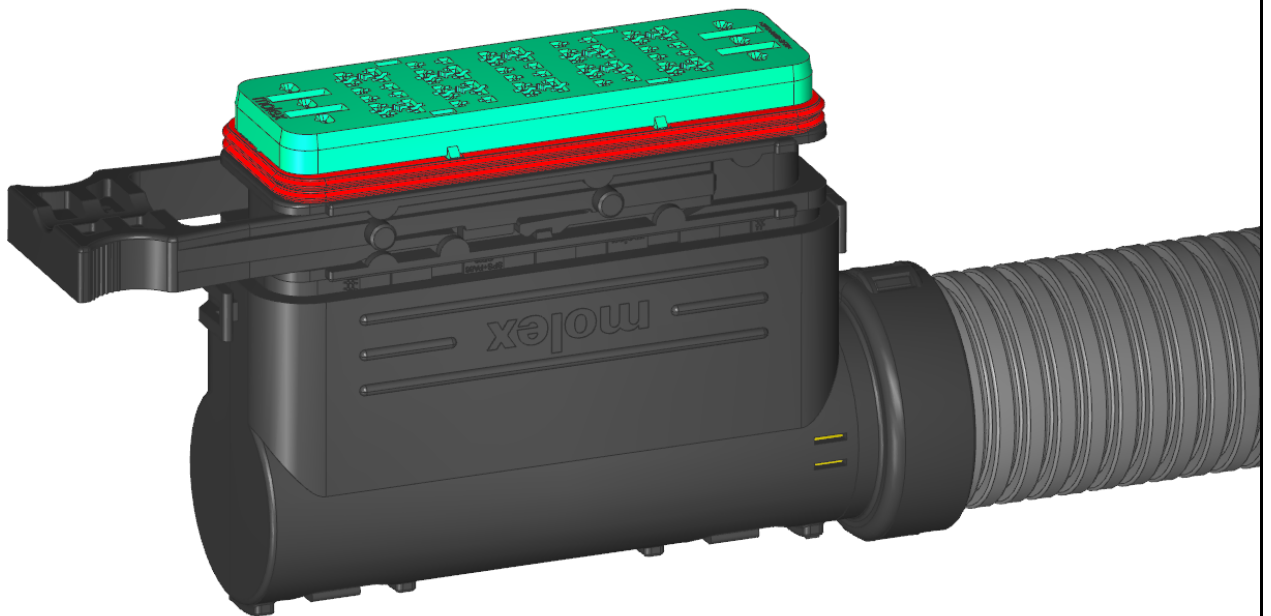

# Mating the connectors

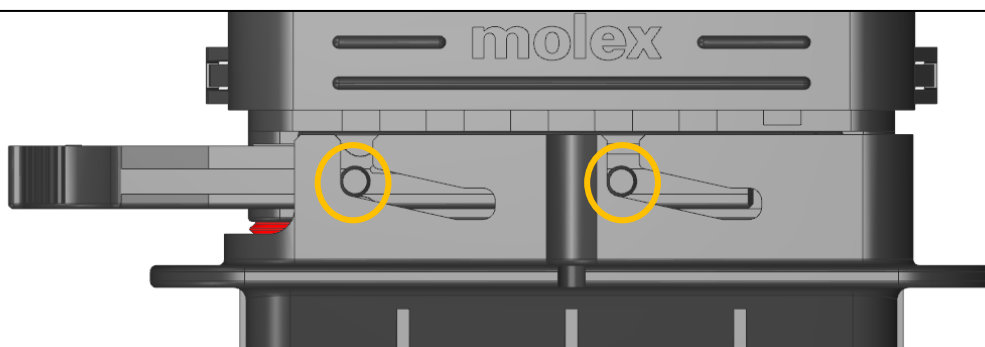
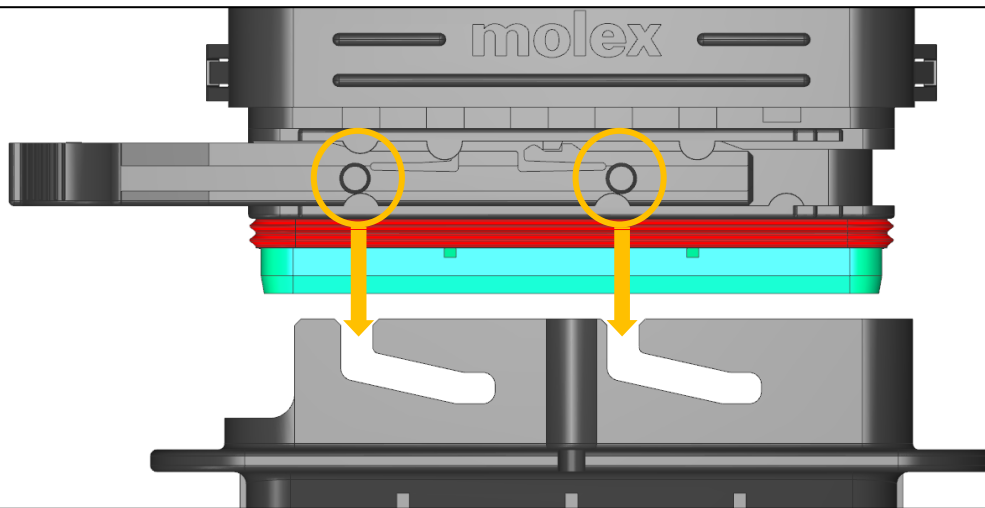
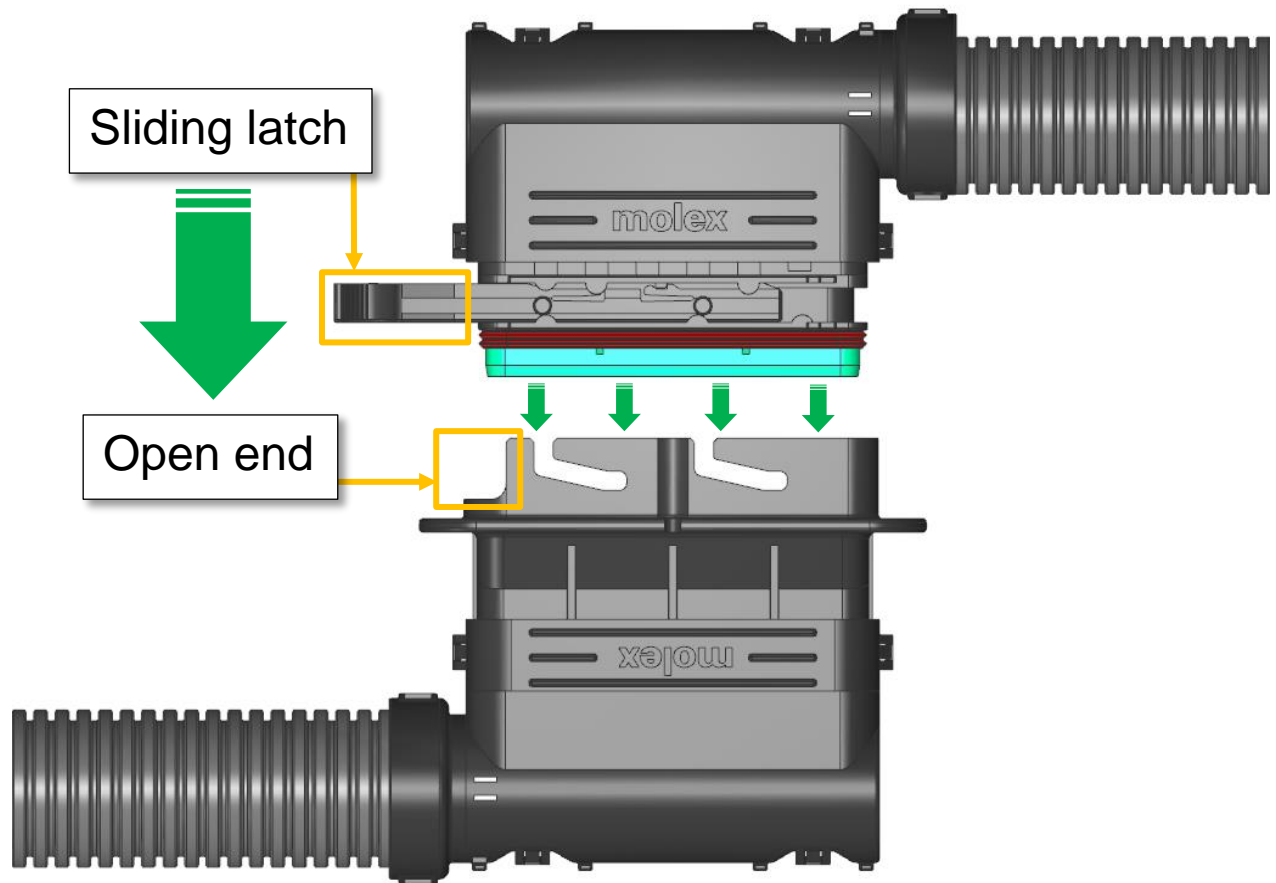

# Mating the connectors

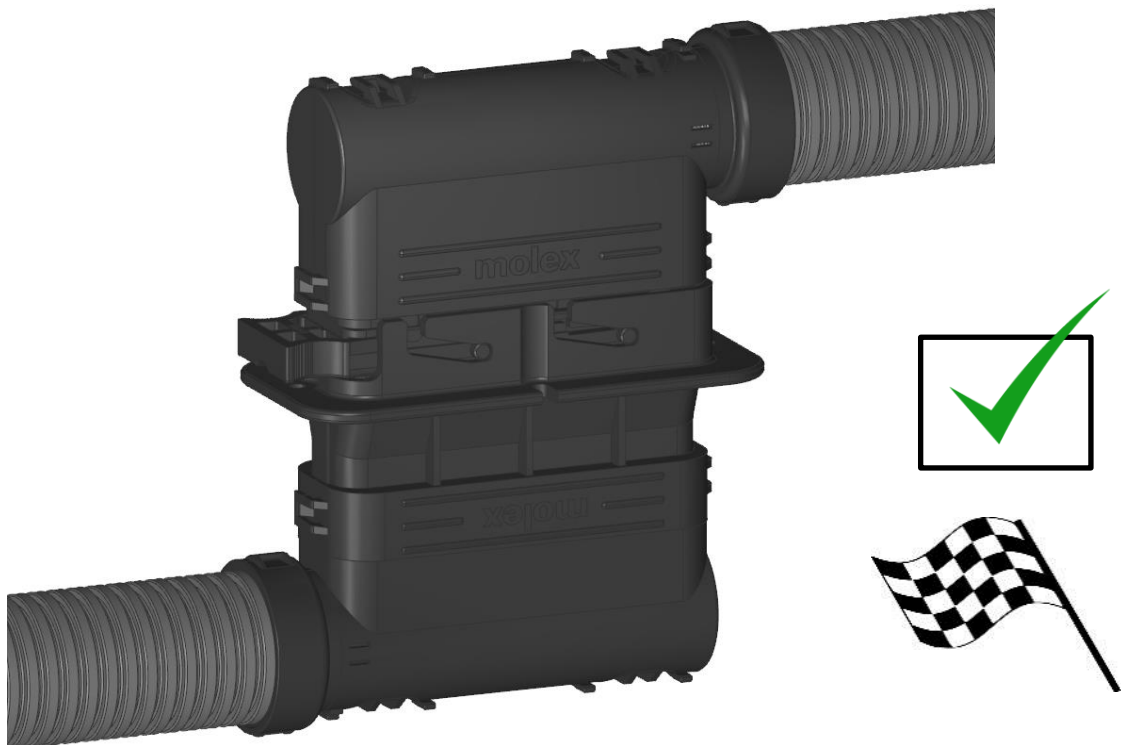
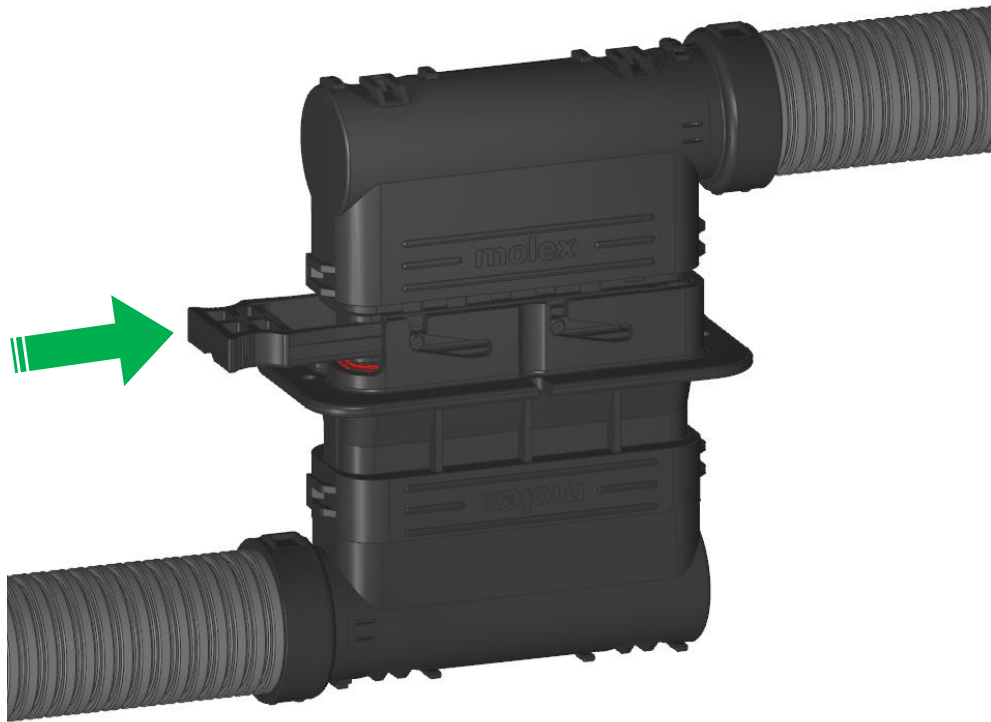

# Unmating the connectors

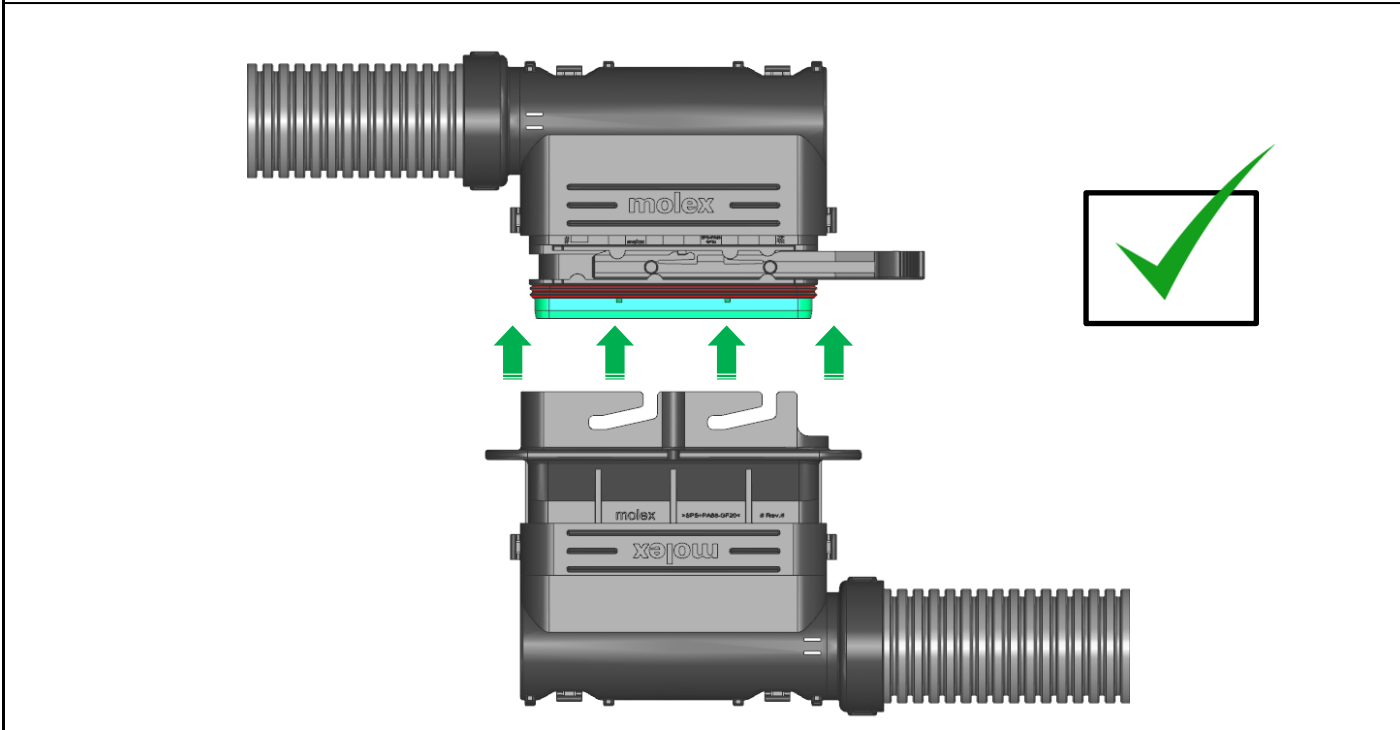
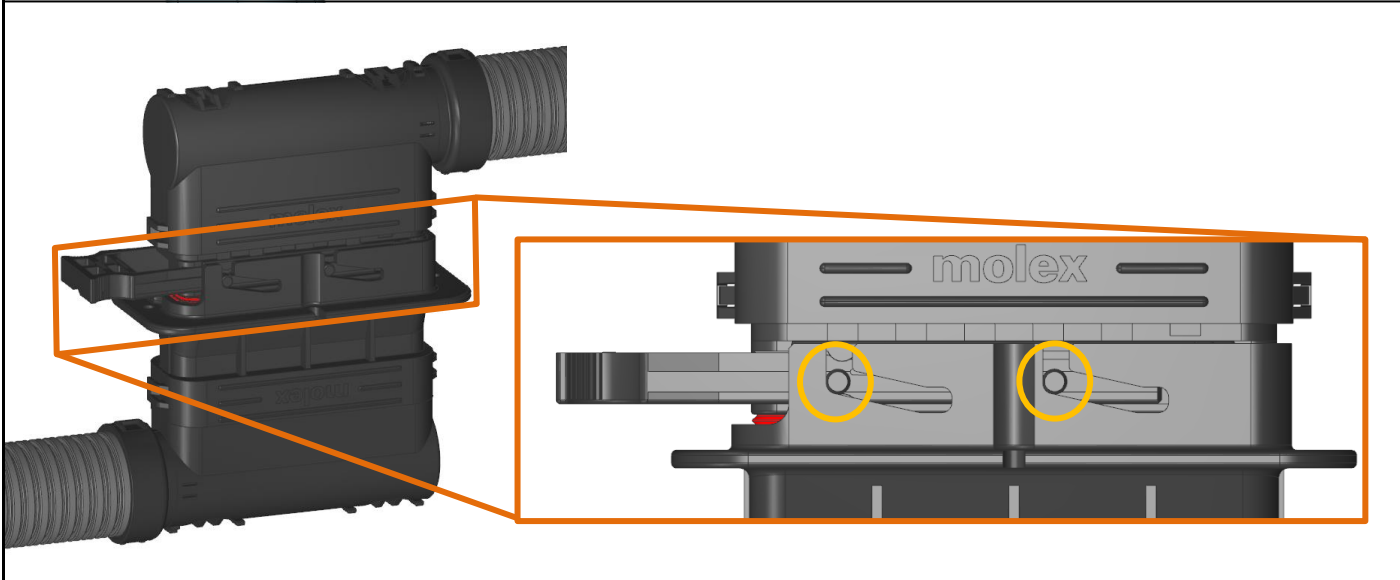
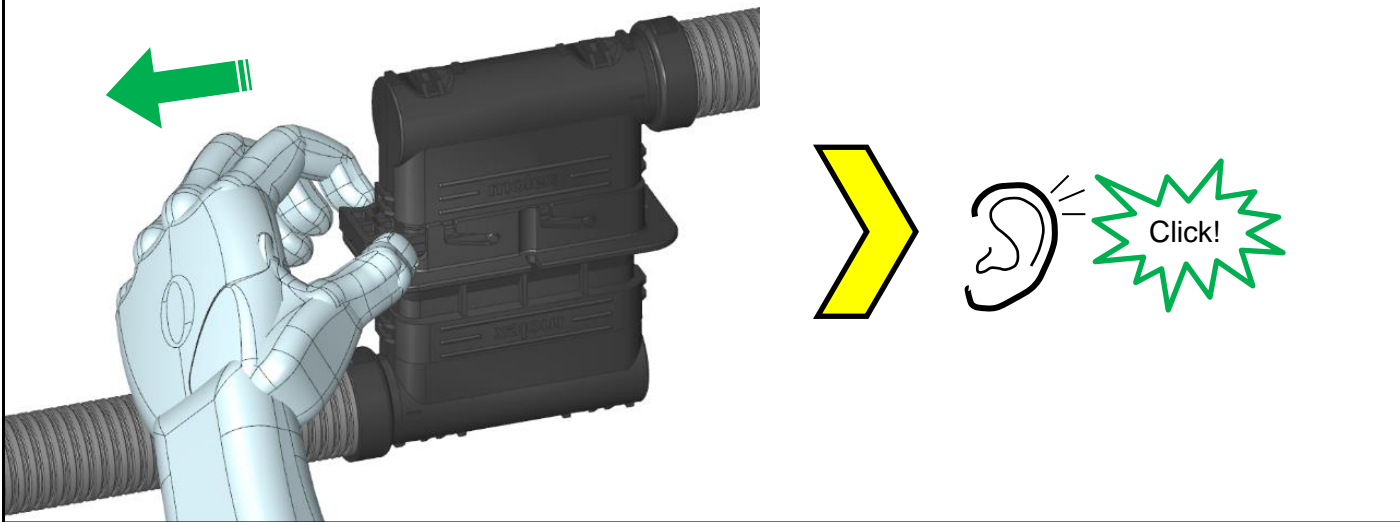



## Suggested removal sequence

Removal sequence same for both male and female connectors

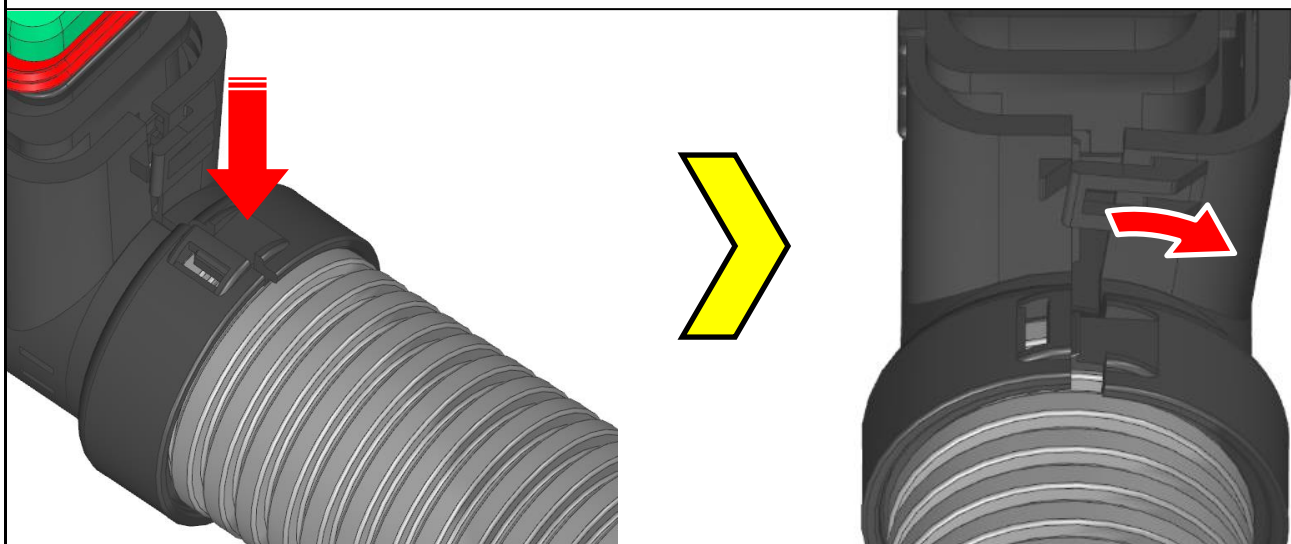
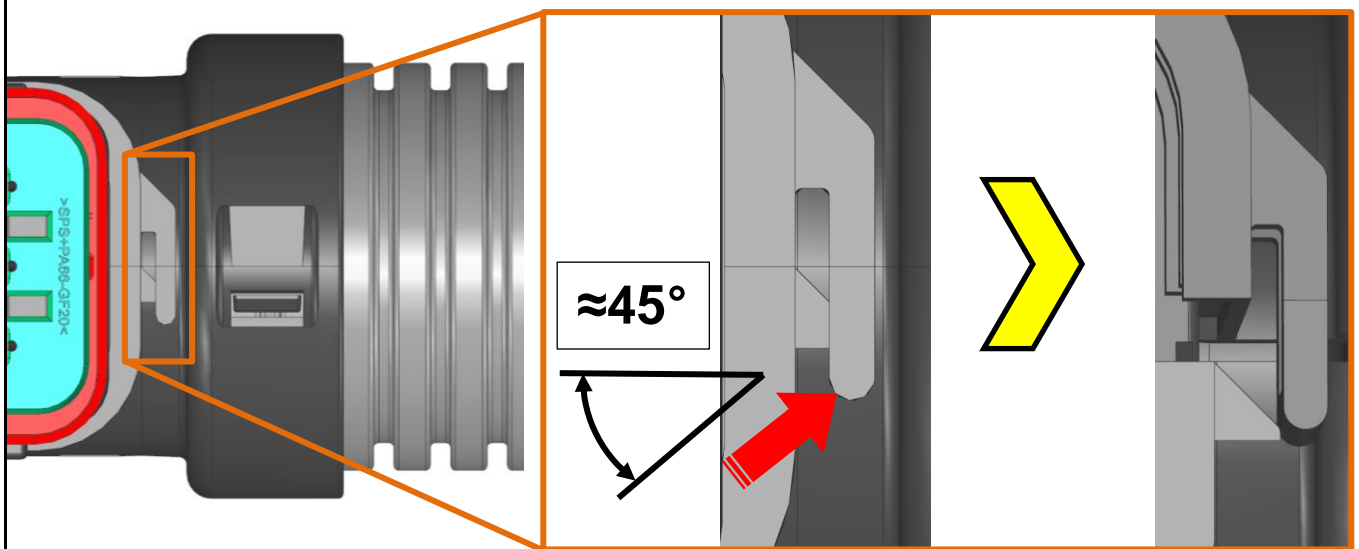
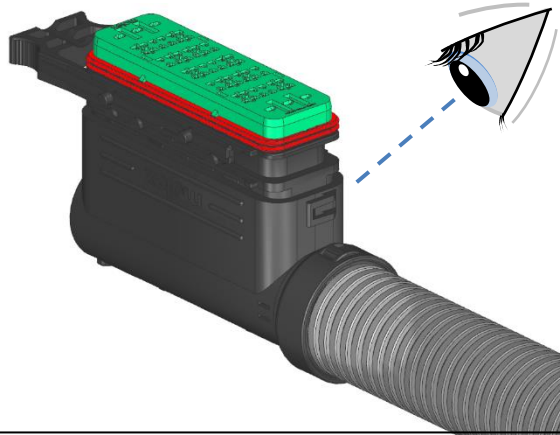

## Suggested removal sequence

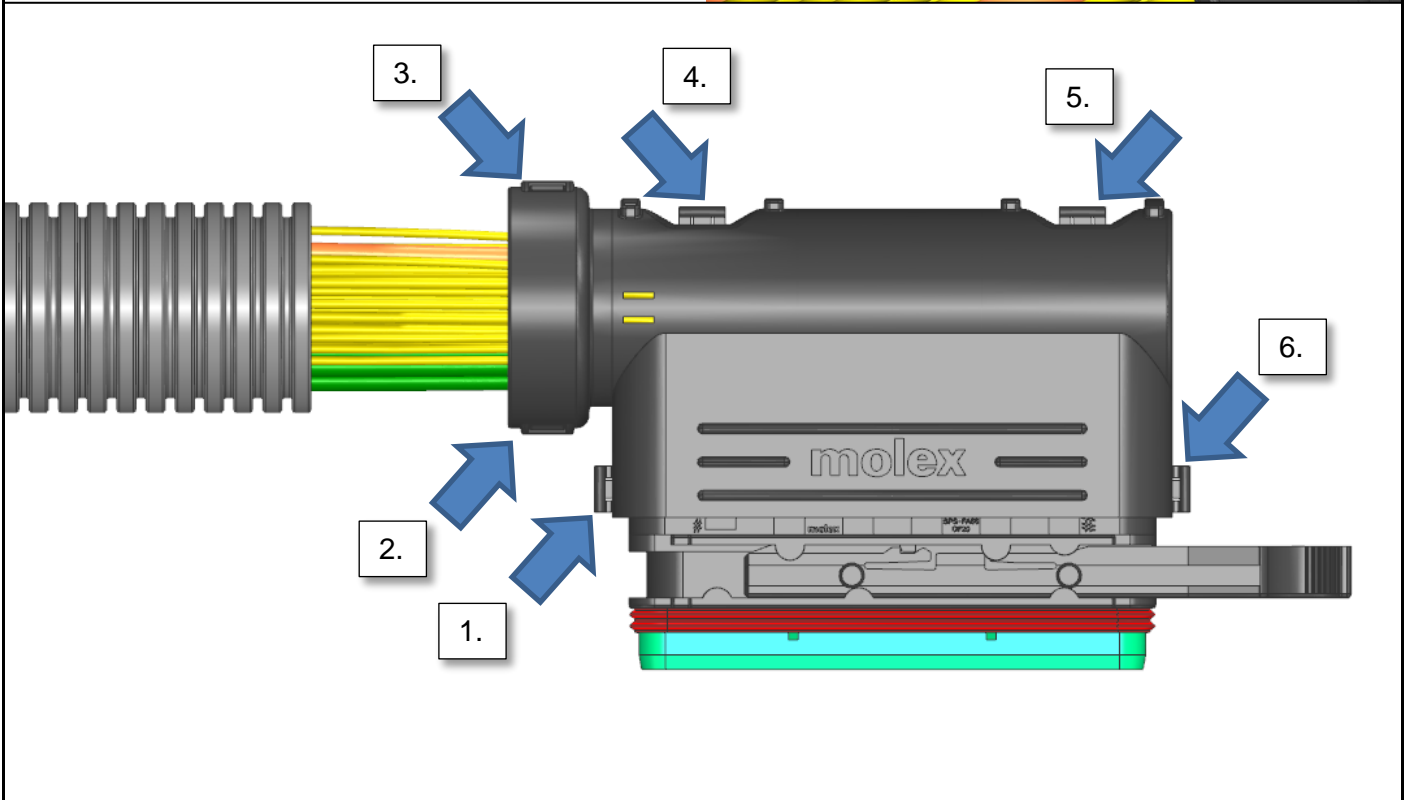
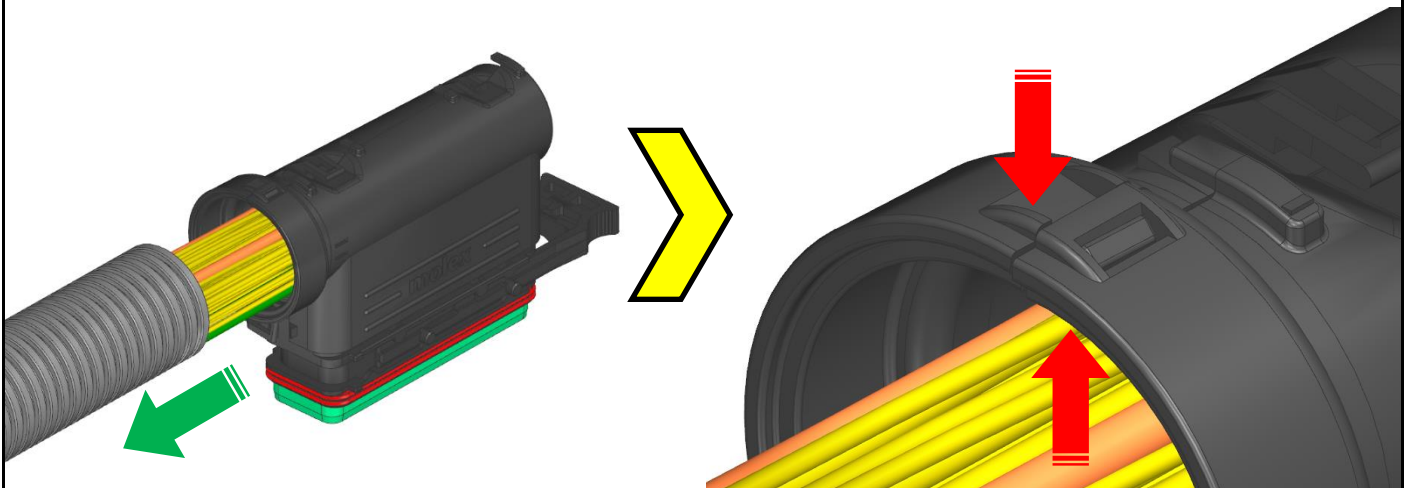

- Recommend sequence above
- Always start at latch nearest the connector
- Easier to start at an open exit side
- Continue de-latching in Clockwise / Anti-clockwise direction
- Same method for each latch & exit

# Removing signal blind cavity plugs from female assembly

**Open TPA – see sheet 6**



**Do not damage cables when removing blind cavity plug**

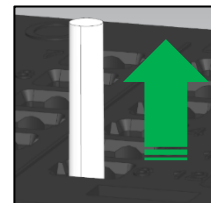
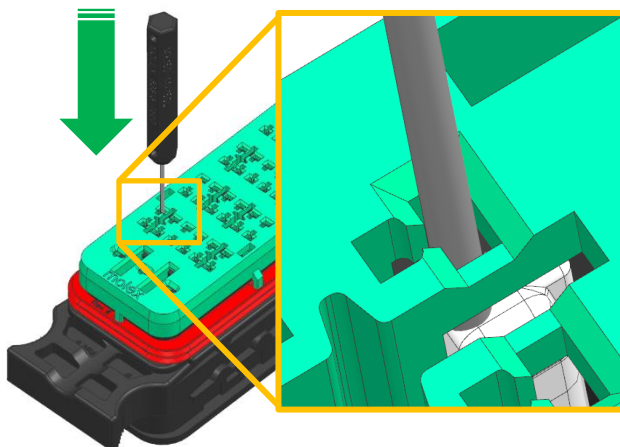
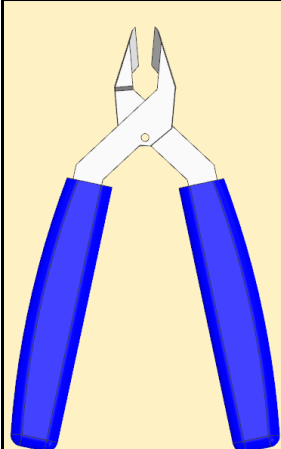

Previously Cut

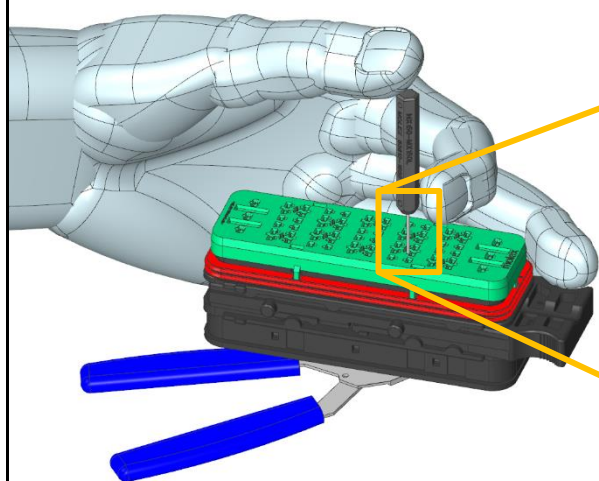

**&**

**Top Tip:**  
A small snips helps grip  
short blind cavity plugs

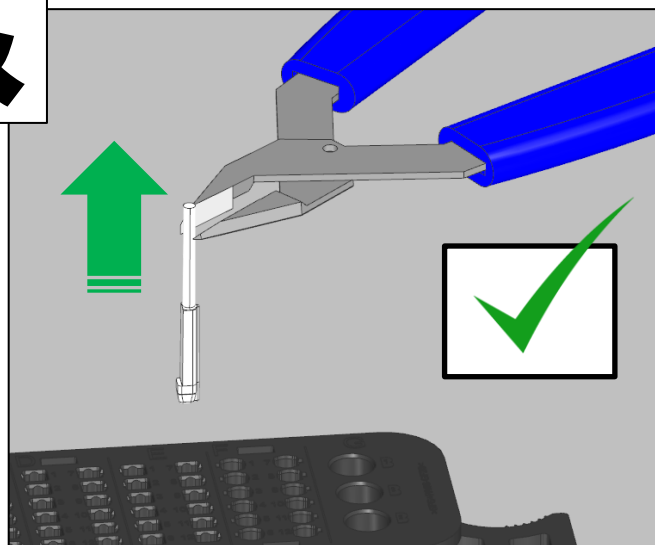
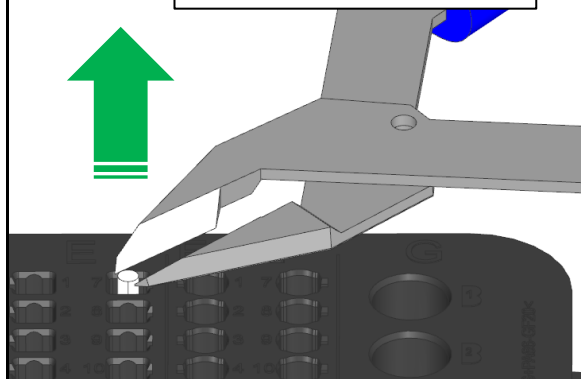

REVISION:  
**C1**

DOCUMENT NUMBER:  
**850830010 PSA**

SHEET No.  
**43 of 52**

# Removing power blind cavity plugs from female assembly

**OPEN TPA – SEE SHEET 6**

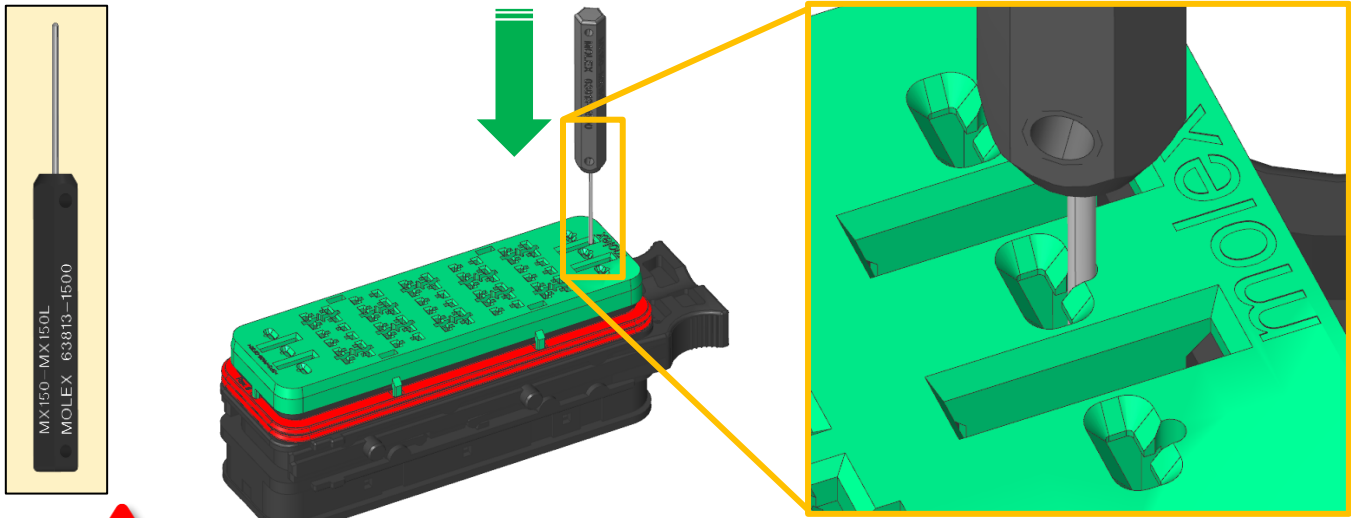

**Special case for female power cavities**

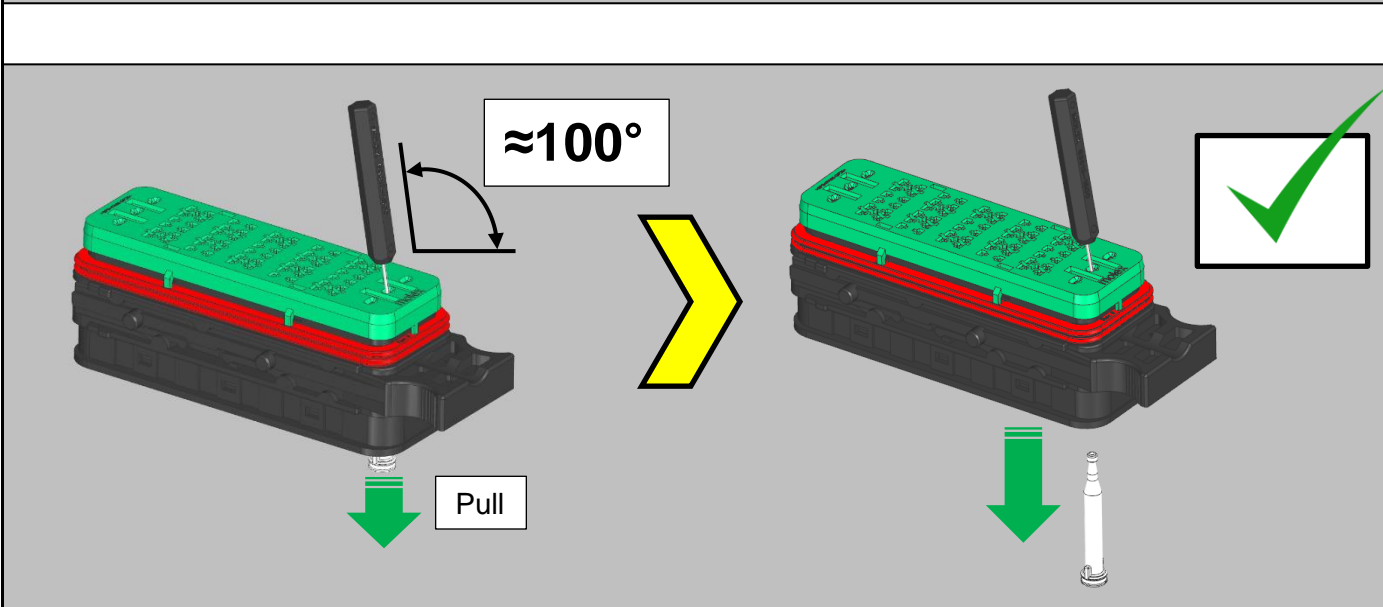
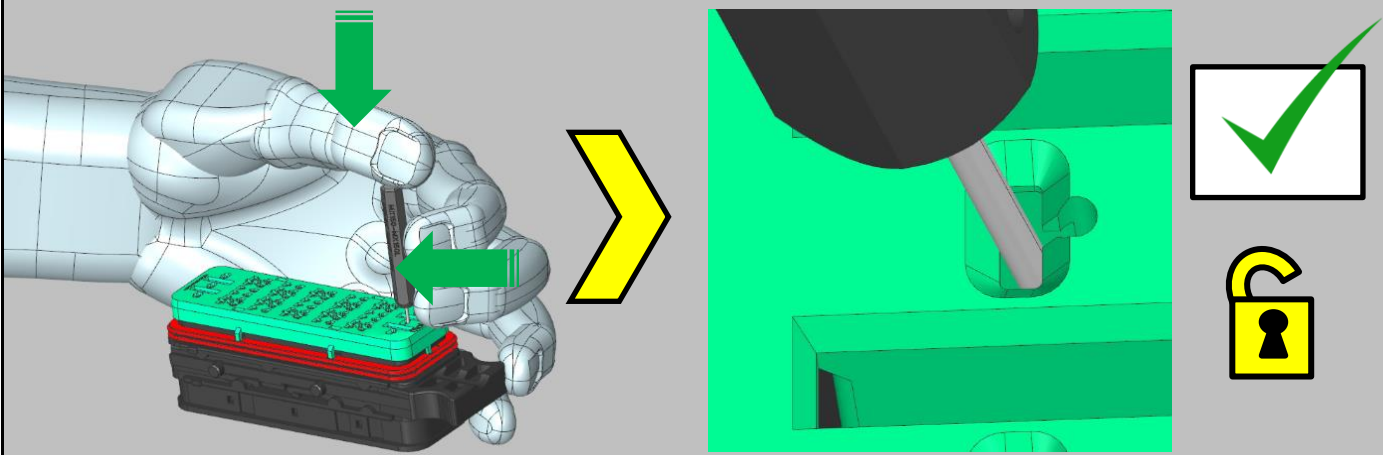

# Removing signal & 2.5mm<sup>2</sup> terminals from female assembly

**OPEN TPA – SEE SHEET 6**

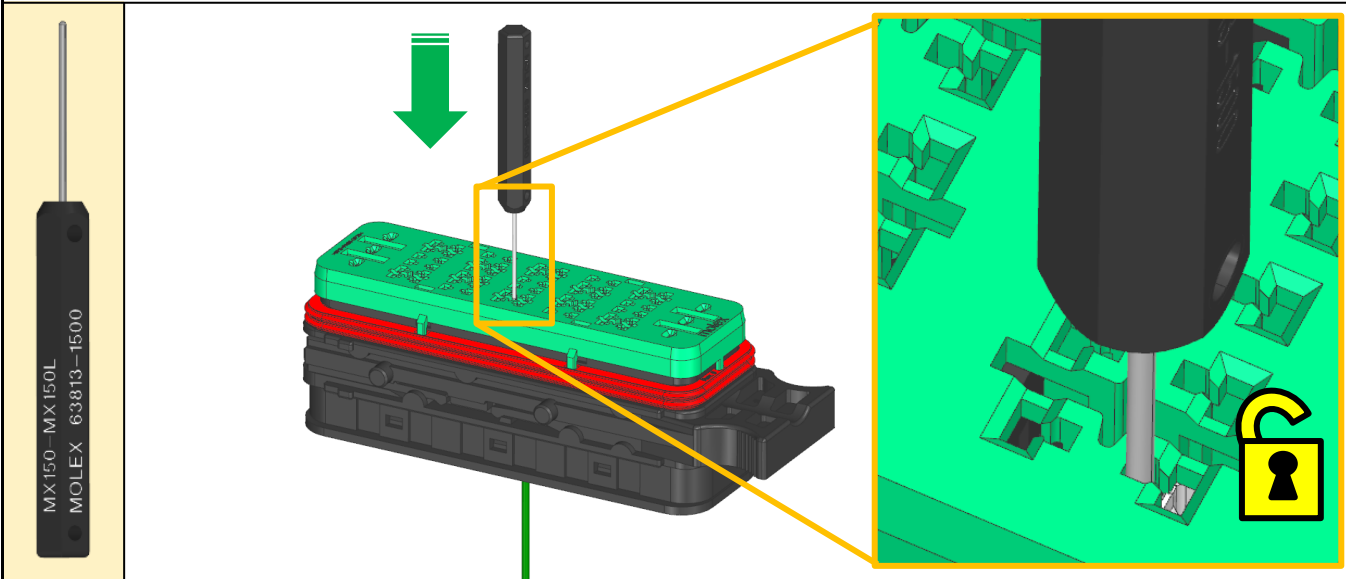

**Pull cables carefully through the seal**

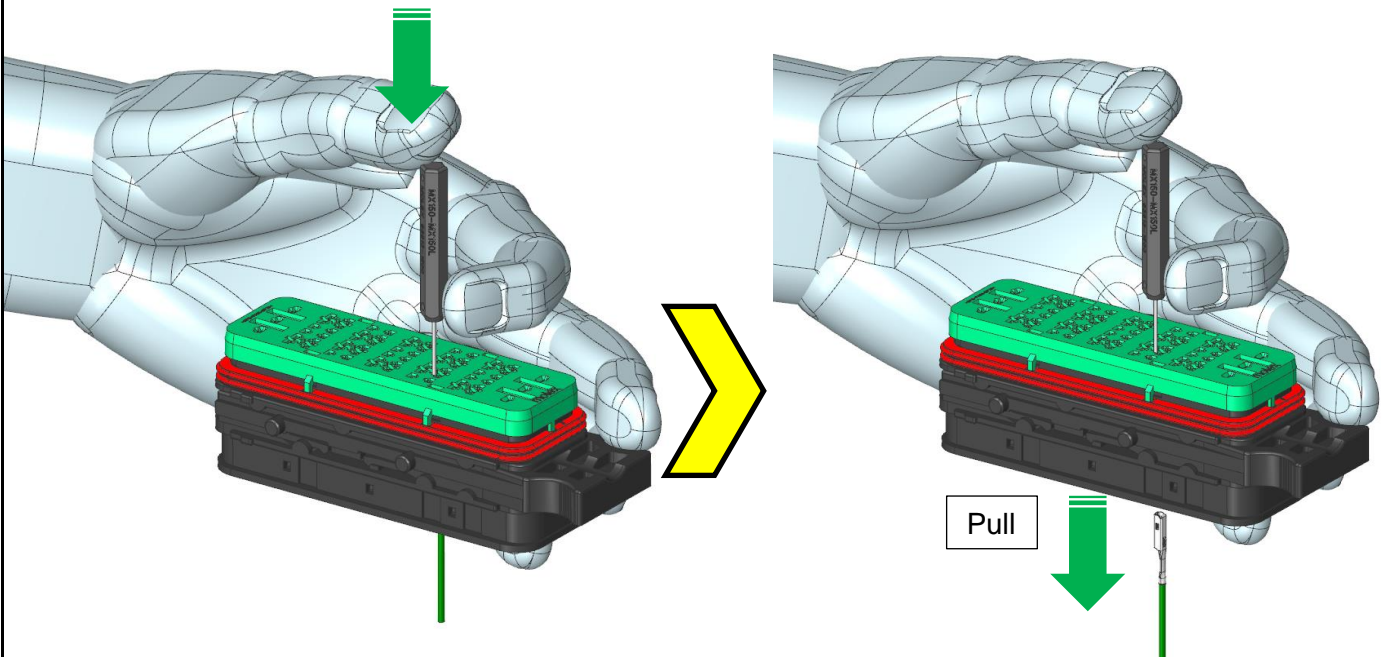

# Removing power terminals from female assembly

**OPEN TPA – SEE SHEET 6**

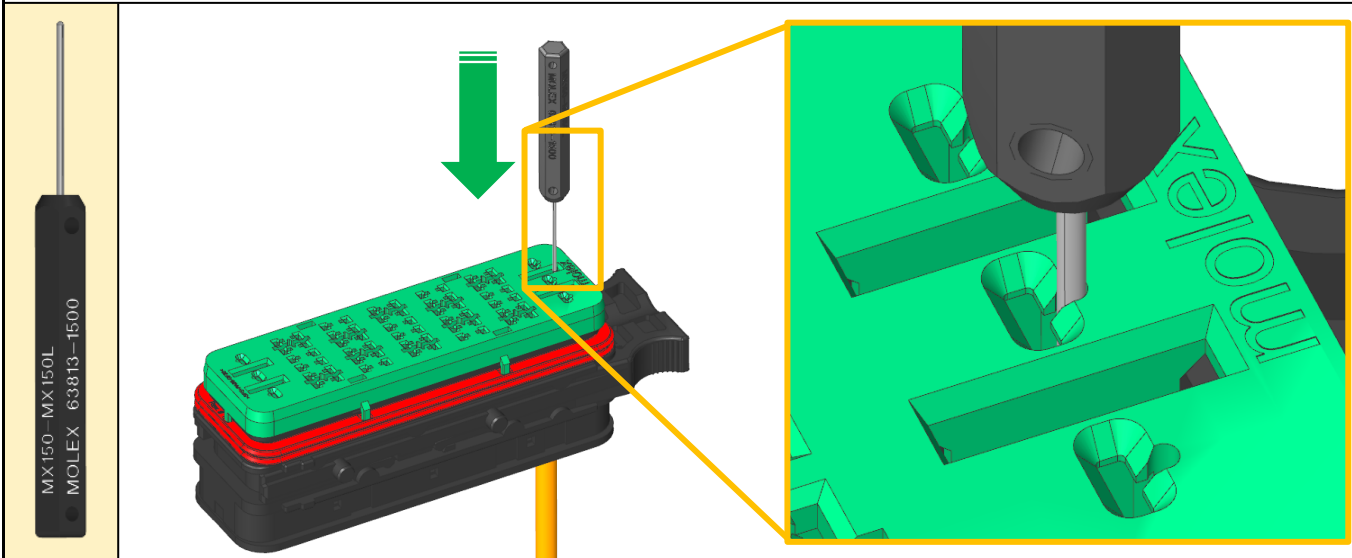

- Special case for female power cavities
- Pull cables carefully through the seal

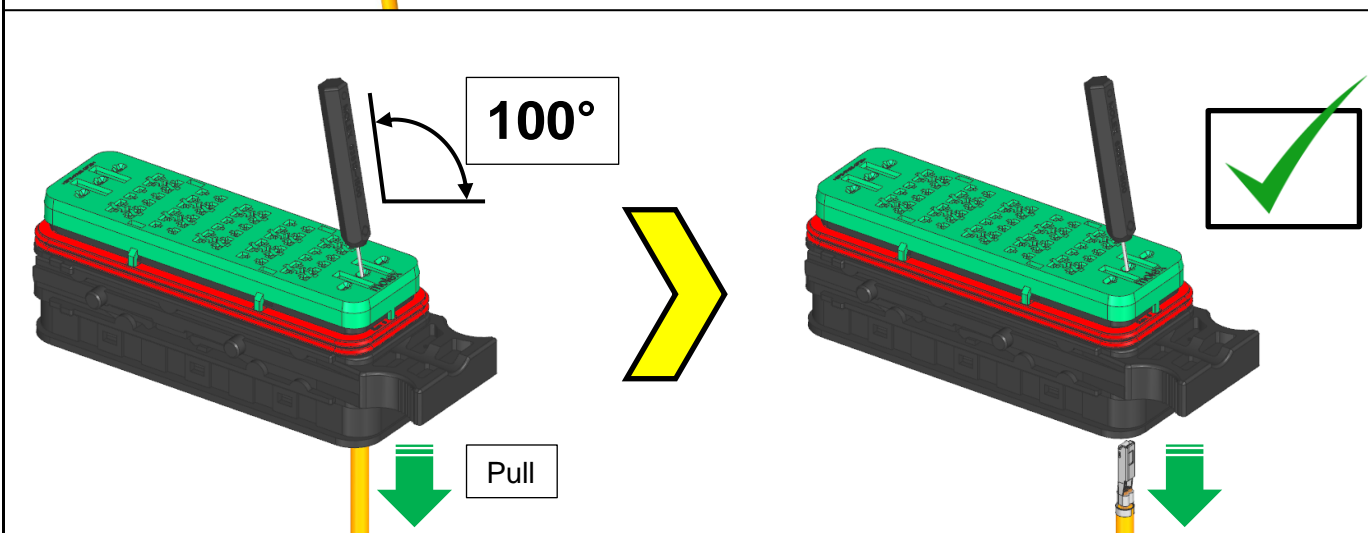
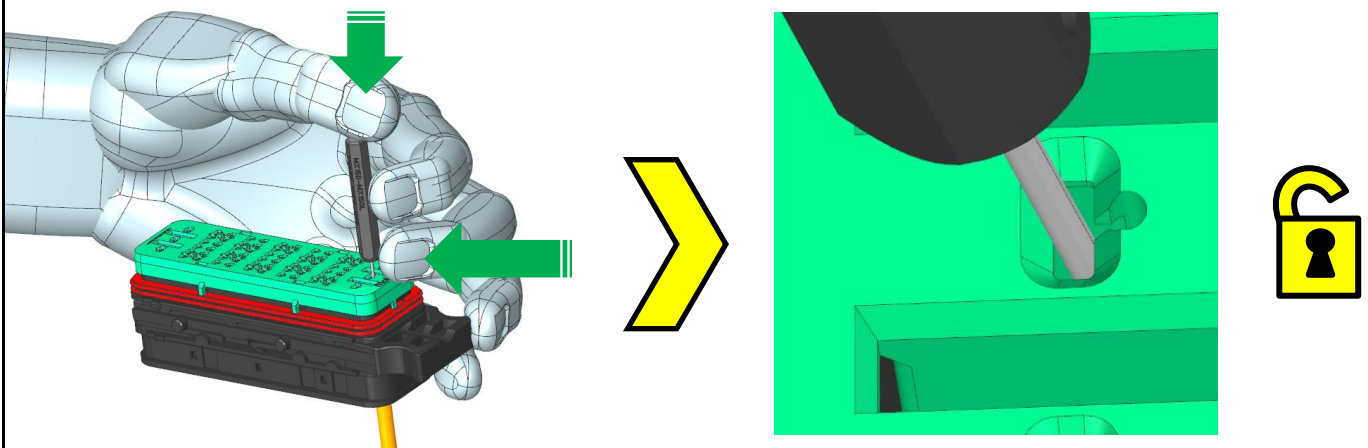

# Removing signal blind cavity plugs from male assembly

**OPEN TPA – SEE SHEET 22**

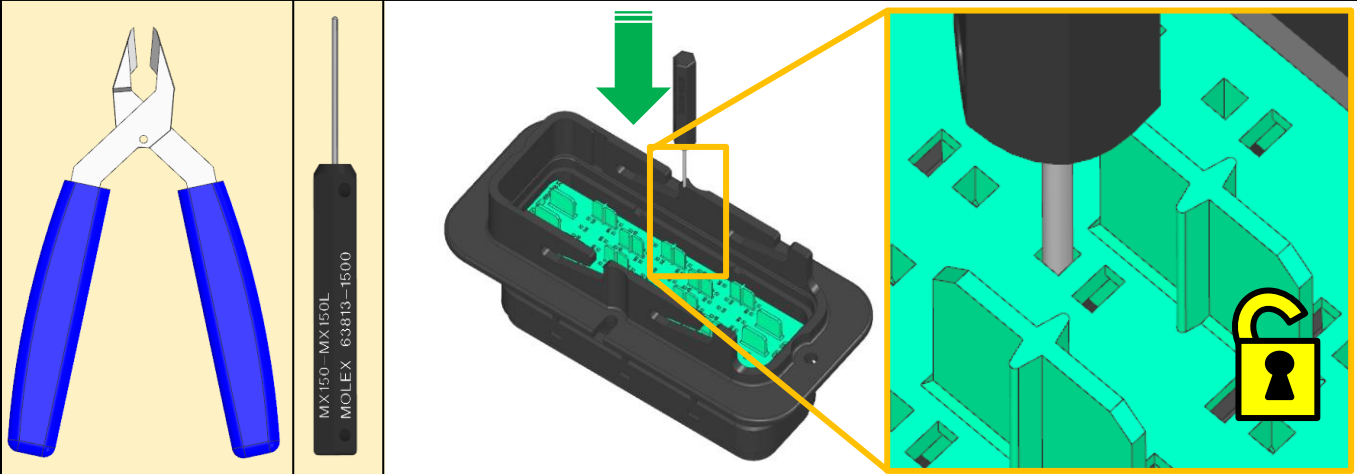

**Top Tip:**  
A small snips helps grip short blind cavity plugs

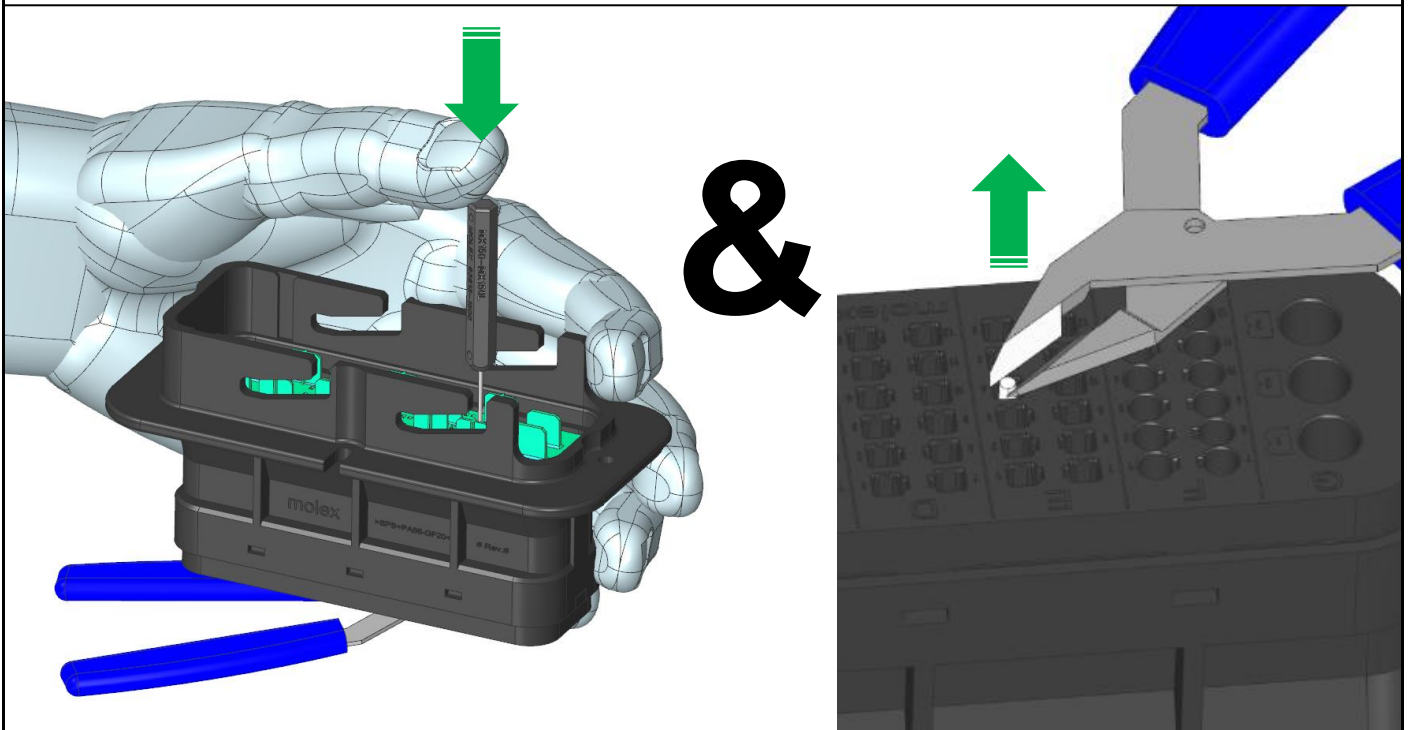

# Removing power blind cavity plugs from male assembly

**OPEN TPA – SEE SHEET 22**

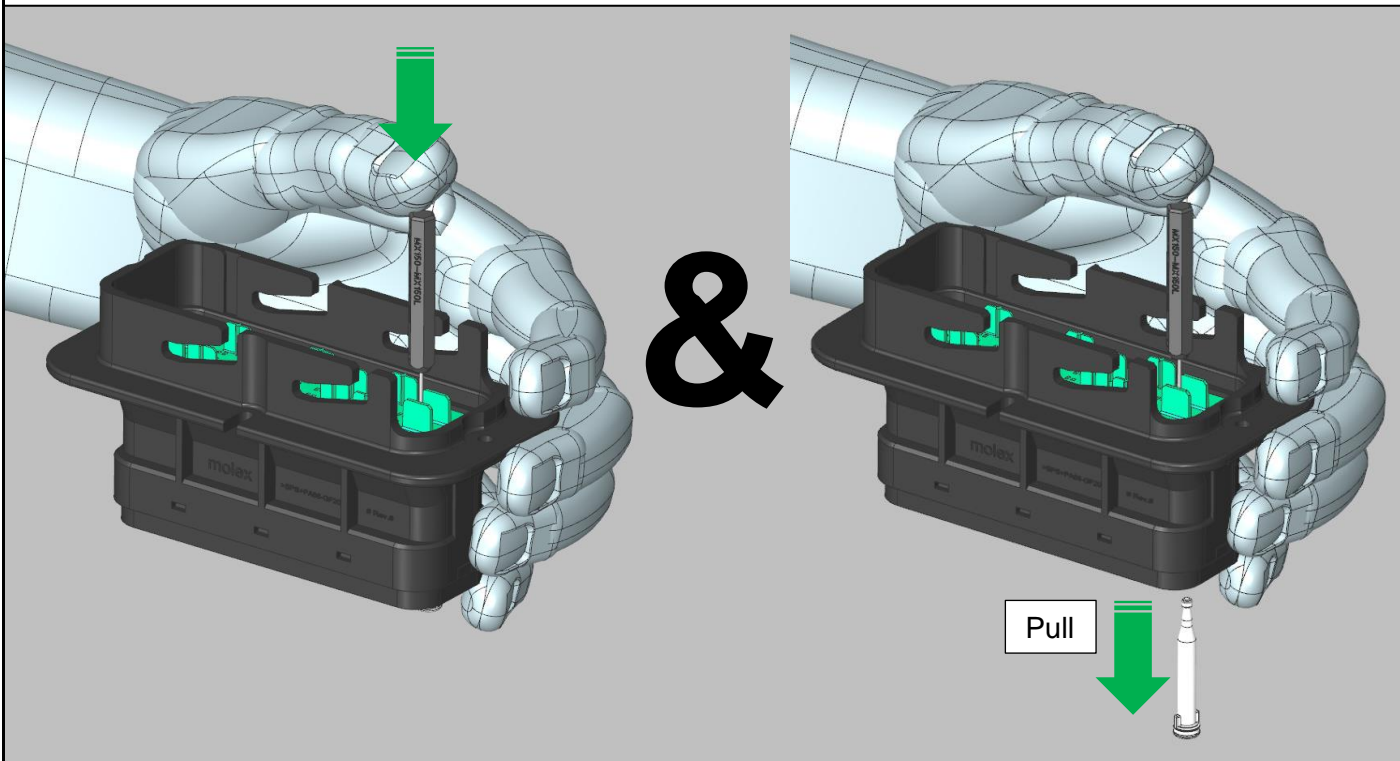
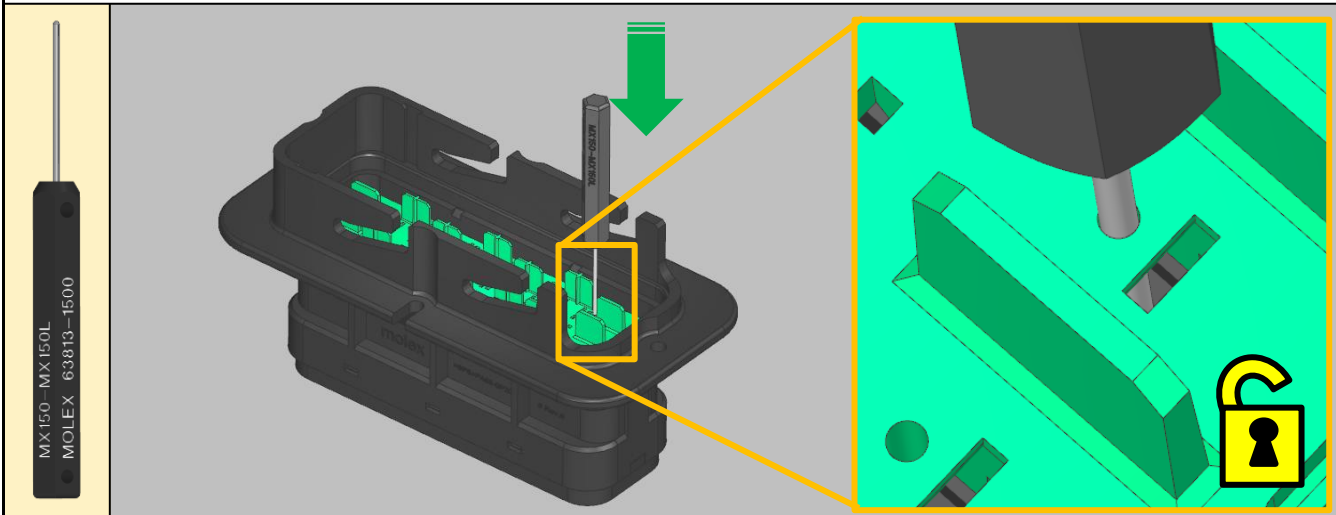



# Removing signal & 2.5mm<sup>2</sup> terminals from male assembly

**OPEN TPA – SEE SHEET 22**

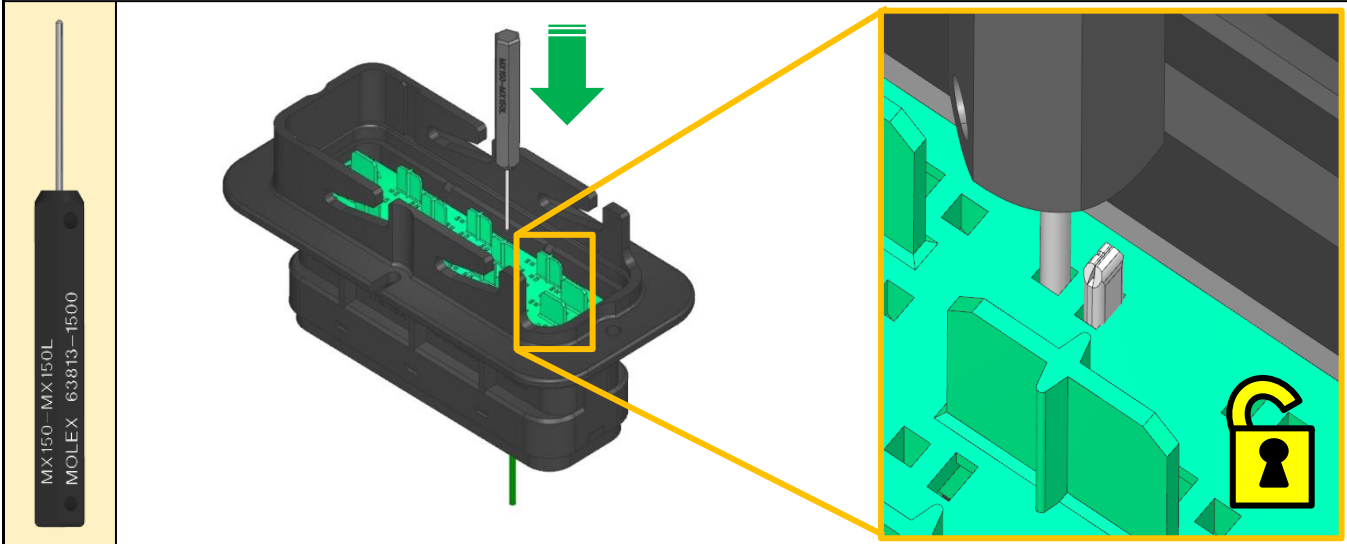

**Pull cables carefully through the seal**

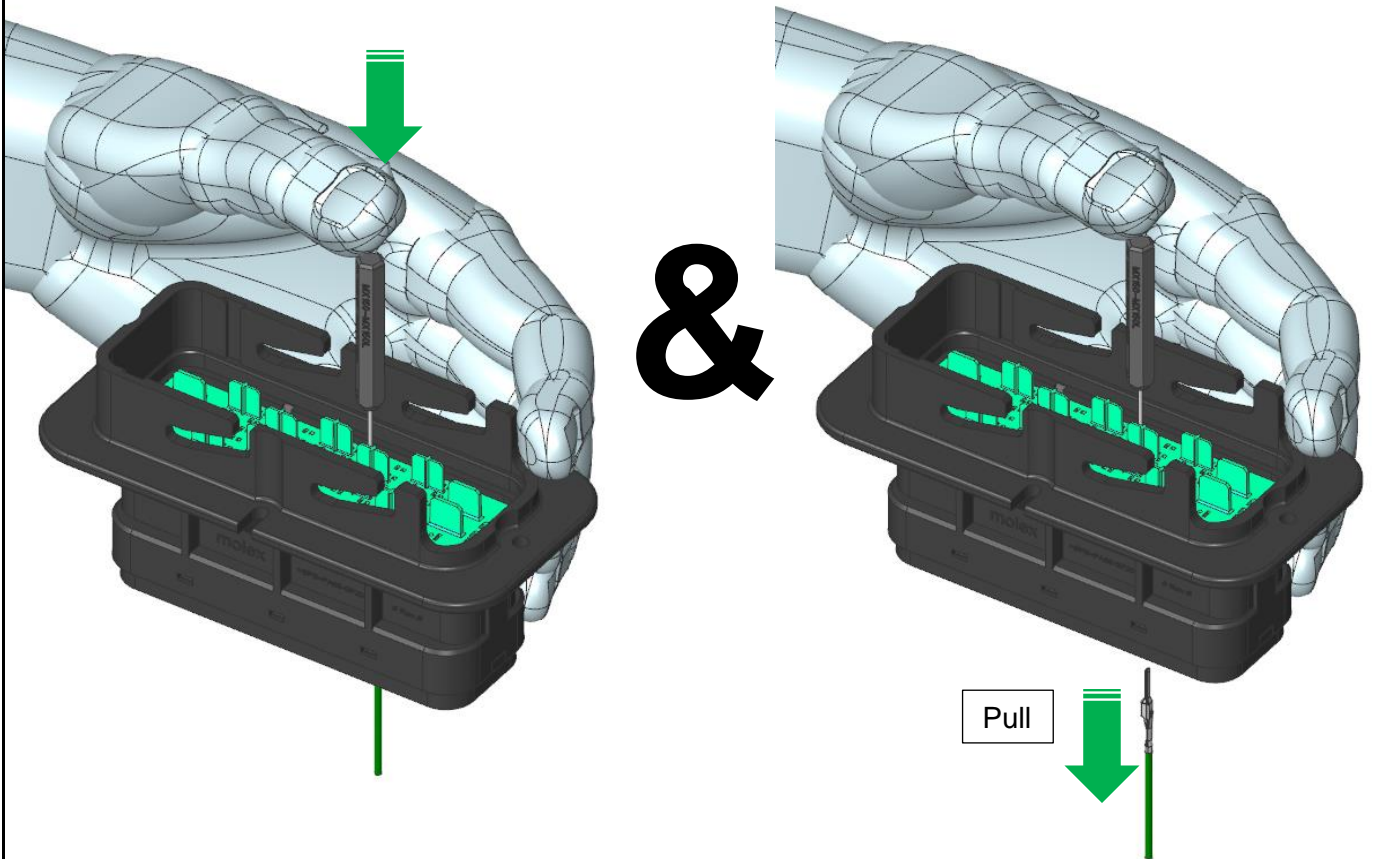

# Removing power terminals from male assembly

**OPEN TPA – SEE SHEET 22**

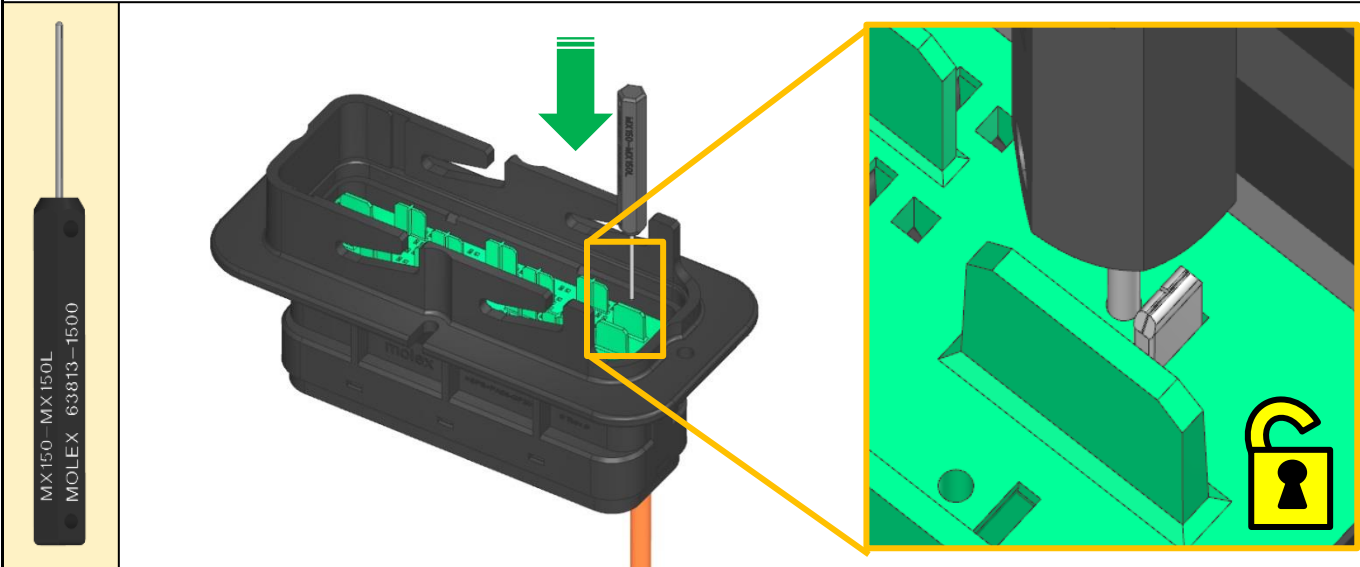

**Pull cables carefully through the seal**

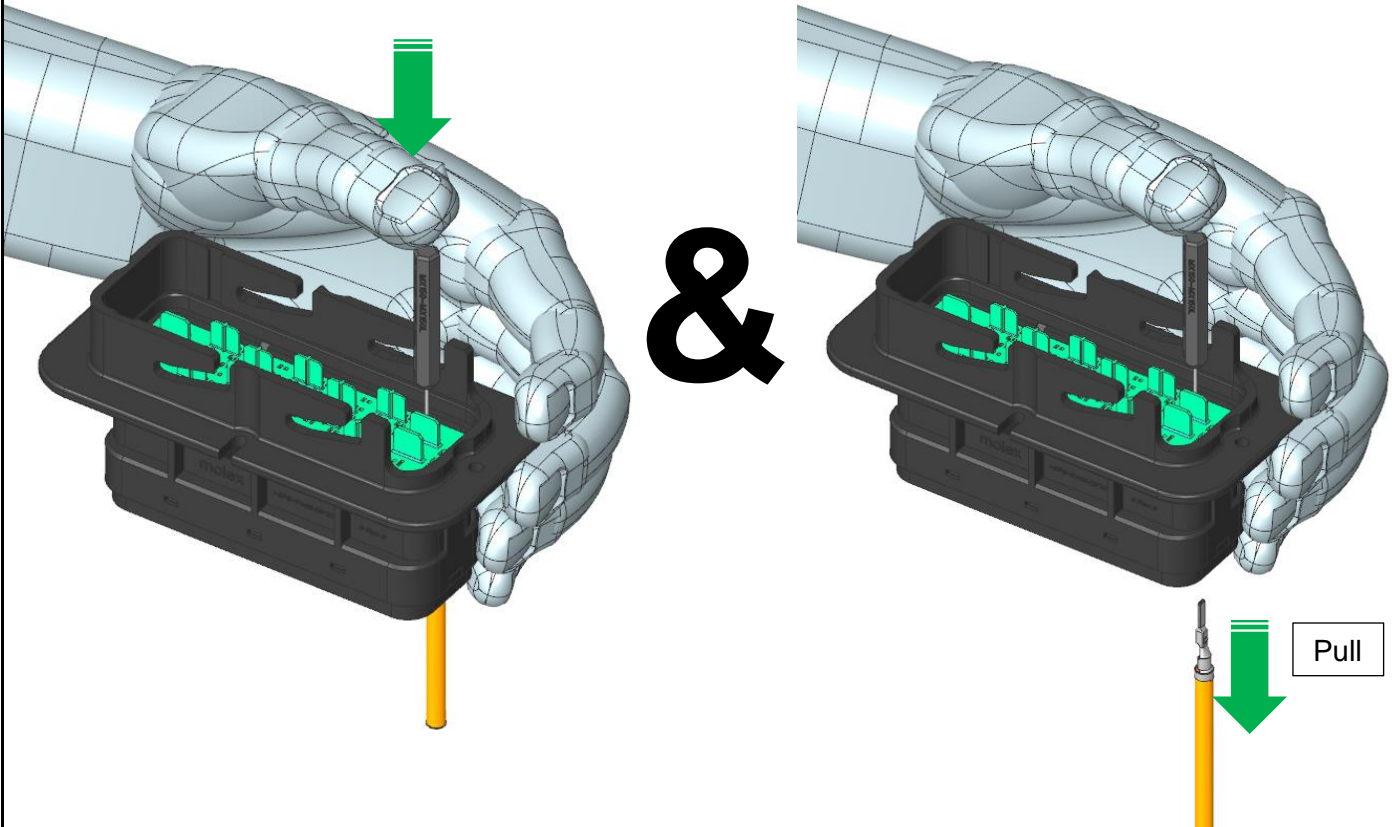

## Disclaimer and Recommendations

1. Tools shown are recommendations only. Molex will not be held responsible if an inappropriate tool is used for terminal removal.
2. Care must be taken when completing the 'Top Tip' sections. Terminal extraction tool must never be inserted into female terminals. Top Tip (page 9) is only ever to be used on signal blind cavity plugs to push them out in the event of over-insertion.
3. Take care when removing blind cavity plugs using a snips as they are easy to cut, the snips is only used to help grip the plugs.
4. Molex recommends trimming the signal blind cavity plugs after insertion. This should always be completed before any wires are assembled into the connector housings.
5. Take care when removing blind cavity plugs from a fully assembled connector, do not damage the neighbouring cables with the snips.
6. Always insert the male terminal at 90° to the rear cover. Insert with care through the seal.
7. When inserting terminals hold the cable approx. 1cm back from the insulation crimp.
8. Conduit must be used in conjunction with the conduit interface/wire dress. Molex will not be held responsible if cables get damaged when conduit is not used with the conduit interface/wire dress. Each cable bundle should occupy a maximum of 70% of each conduit exit.
9. **This instruction manual shows a 60+6 configuration for demonstration purposes only. Always ensure the appropriate harness wiring diagram is followed.**
10. Power blind cavity plugs must be pulled fully back in the female housing before the TPA is closed.
11. Terminal and blind cavity plug removal – parts must be pulled out of assembly in the direction shown by the green arrow in the pictures.
12. Before mating connectors please ensure both connectors are fully populated and that the final checks have been completed.

## Reference documents

850830300 PSD	SRC Mixed Power Male Assembly Sales Drawing (Standard Rear Cover)
932880001 PSD	SRC 84 Pin Male Housing Assembly Sales Drawing (Standard Rear Cover)
932870001 PSD	SRC 84 Pin Female Receptacle Housing Assembly Sales Drawing
937921000 PSD	SRC Mixed Power Male Assembly Sales Drawing (Extended Rear Cover)
850840700 PSD	SRC Mixed Power Female Receptacle Housing Assembly Sales Drawing
934811000 PSD	SRC Conduit Interface Sales Drawing
850830010 PSP	SRC Male and Female Mixed Power Assembly Product Specification
937921000 PSK	SRC Male Assembly Packaging Specification (Extended Rear Cover)
850710010 PSK	SRC Male Blade Housing Assembly Packaging Specification
850700010 PSK	SRC Female Receptacle Housing Packaging Specification
934811000 PSK	SRC Conduit interface Packaging Specification
934811000 PSP	SRC Conduit interface Product Specification
SD-19431-***	MX150L Various Male Blade Terminal Sales Drawings
SD-19434-***	MX150L Various Female Receptacle Terminal Sales Drawings
SD-33000-001	MX150 Male Blade Terminal Sales Drawing
SD-33012-002	MX150 Female Receptacle Terminal Sales Drawing
937320001 PSD	SRC Power Blind Cavity Plug Sales Drawing
937320001 PSK	SRC Power Blind Cavity Plug Packaging Specification
937320001 PSP	SRC Power Blind Cavity Plug Product Specification
936420010 PSD	SRC 2.5mm <sup>2</sup> Blade Terminal Sales Drawing
936420010 PSK	SRC 2.5mm <sup>2</sup> Blade Terminal Packaging Specification
936430010 PSD	SRC 2.5mm <sup>2</sup> Receptacle Terminal Sales Drawing
936430010 PSK	SRC 2.5mm <sup>2</sup> Receptacle Terminal Packaging Specification
936420010 PSP	SRC 2.5mm <sup>2</sup> Terminal Product Specification

REVISION:  
**C1**

DOCUMENT NUMBER:  
**850830010 PSA**

SHEET No.  
**51 of 52**

Thanks for choosing molex

**molex**<sup>®</sup>  
one company › a world of innovation