

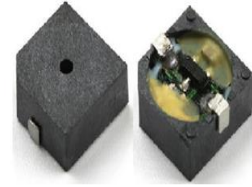

PUIaudio



Data Sheet

SMI-1027-T-5V-R

Features:

- Light weight, only 0.8 grams
- 83dB output with 5VDC input
- Reflow solder acceptable
- Non-washable design for use with no-clean solder process

Specifications

Parameters	Values	Units
Rated Voltage	5	VDC
Operating Voltage Range	3 ~ 6.5	VDC
Current Draw at Rated Voltage	≤30	mA
Minimum SPL @ 10cm	≥83	dBA
Resonant Frequency	2700±270	Hz
Tone or Pulse Rate	Continuous	-
Housing Material	LCP	-
Terminal Material		-
Weight	0.8	Grams
Acceptable Soldering Methods	Hand Solder, Reflow Solder	See below for soldering information
Environmental Compliances	RoHS/REACH	-
Storage Temperature	-40 ~ +90	°C
Operating Temperature	-40 ~ +85	°C

Measurement Method (5Vdc, 10cm)

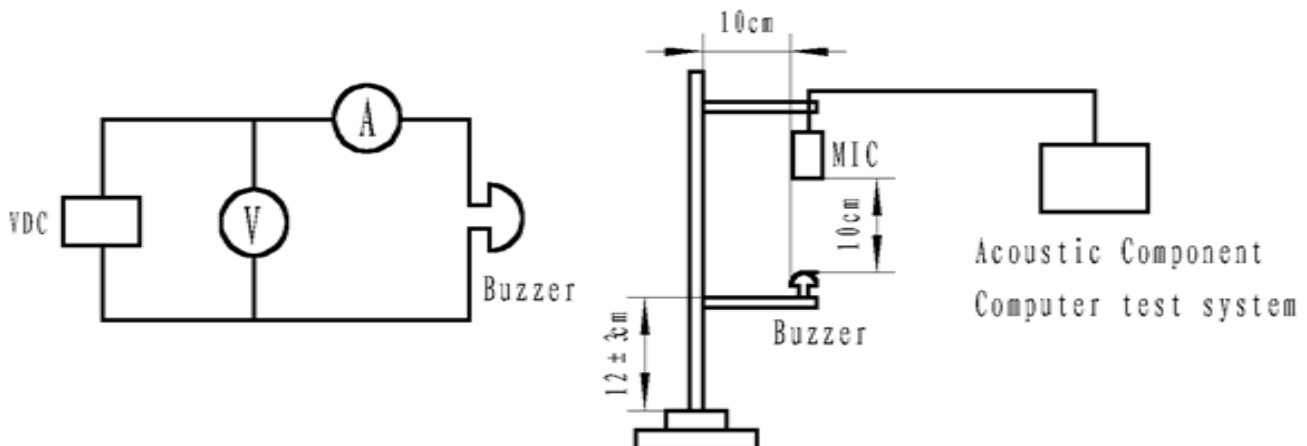

Typical SPL vs Input Voltage

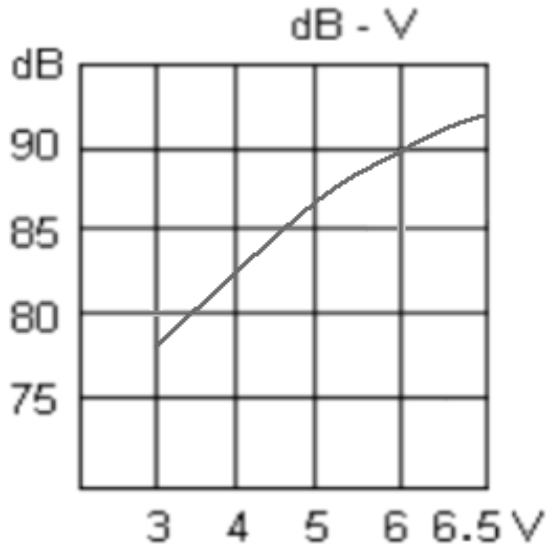

Typical Current Draw vs Input Voltage

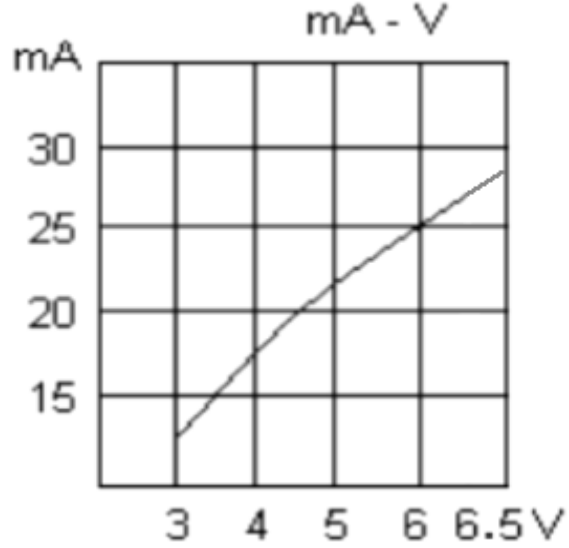

Recommended Soldering Procedure

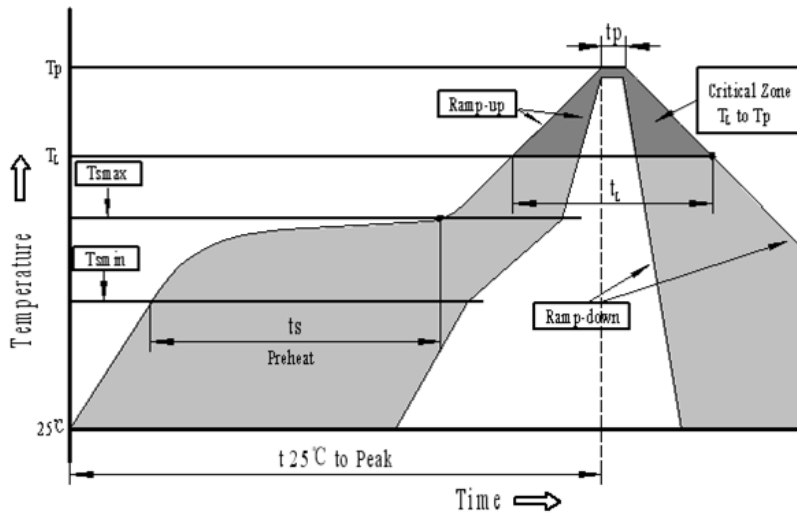

Profile Feature	Pb-Free Assembly
Average ramp-up rate(T_L to T_p)	3°C/second max.
Preheat	
-Temperature Min. (T_{smin})	150°C
-Temperature Min. (T_{smax})	200°C
-Temperature Min. (t_s)	60~180 seconds
T_{smax} to T_L	
-Ramp-up Rate	3°C/second max.
Time maintained above:	
- Temperature(T_L)	217°C
-Time(T_L)	60~150 seconds
Peak temperature(T_p)	245°C+0/-5°C
Time within 5°C of actual Peak temperature (t_p)	6 seconds max.
Ramp-down Rate	6°C/second max.
Time 25°C to Peak Temperature	8 minutes max.

Reliability Testing

Type of Test	Test Specifications
High Temperature Test	The part shall be capable of withstanding a storage temperature of +90°C for 120 hours
Low Temperature Test	The part shall be capable of withstanding a storage temperature of -40°C for 120 hours
Humidity Test	40±2°C, 90~95% RH, 120 hours
Temperature Cycle Testing	A total 5 cycles, 1 cycle consists of: -40±2°C, 30 minutes 20±5°C, 15 minutes 90±2°C, 30 minutes 20±5°C, 15 minutes
Vibration Test	The part shall be subjected to a vibration cycle of 10Hz in a period of 1 minute. Total peak amplitude shall be 1.52mm (9.3g). The vibration test shall consist of 2 hours per plane in each three mutually perpendicular planes for a total time of 6 hours.
Shock Test	The part shall be measured after being applied shock (980m/s ²) for each three mutually perpendicular directions, each 3 times by a half sine wave.
Drop Test	Drop part from a 70cm height onto the surface of a 10mm thick wooden board. Applied to the top and side.

2 hours after the test the part shall meet specifications without any degradation in appearance and performance except SPL shall be ±10dB of the initial value.

Dimensions (Positive solder pad is on the right in the right image below)

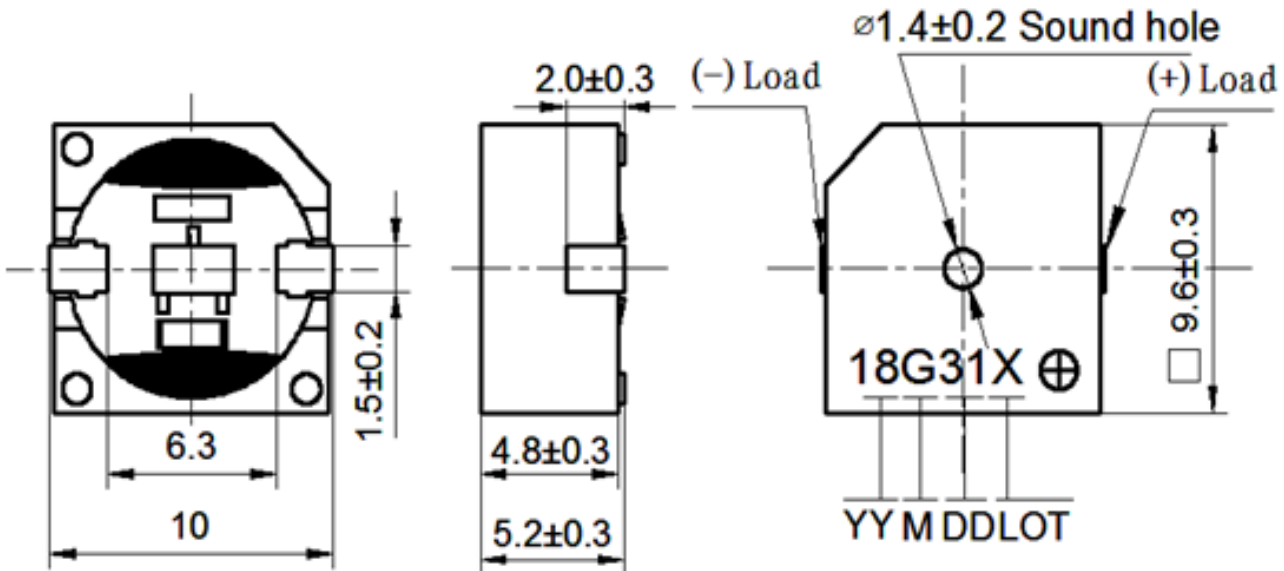

Suggested Land Pattern*

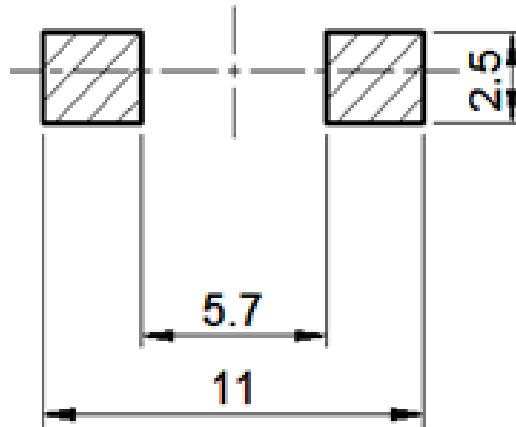

*This land pattern is advisory only and its use or adaptation is entirely voluntary. PUI Audio disclaims all liability of any kind associated with the use, application, or adaptation of this land pattern.

Packaging

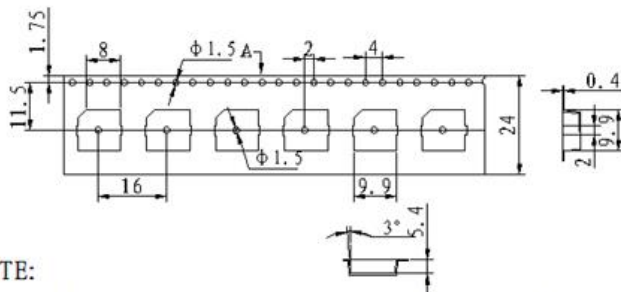

NOTE:

1. 10 sprocket hole pitch cumulative tolerance $\pm 0.20\text{mm}$.
2. All dimensions meet EIA-481-D requirements.
3. Thickness: $0.4 \pm 0.05\text{mm}$.
4. Component loaded per 13" reel: 700pcs.

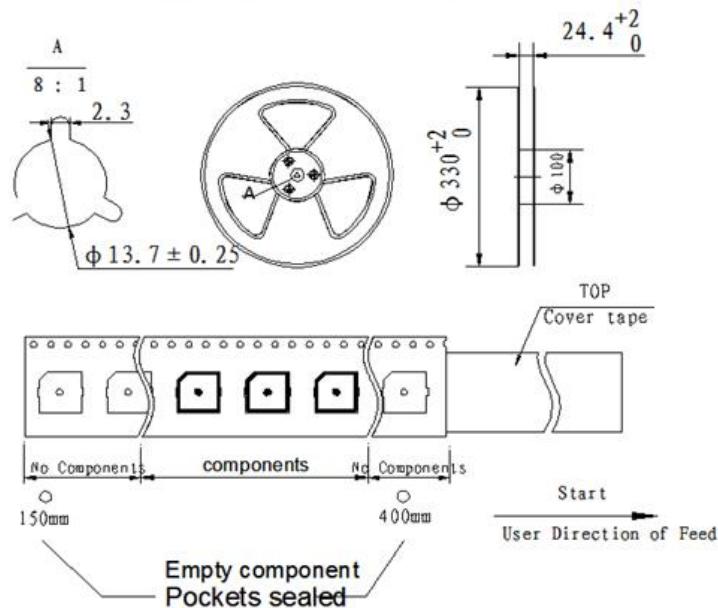

Packaging Cont'd

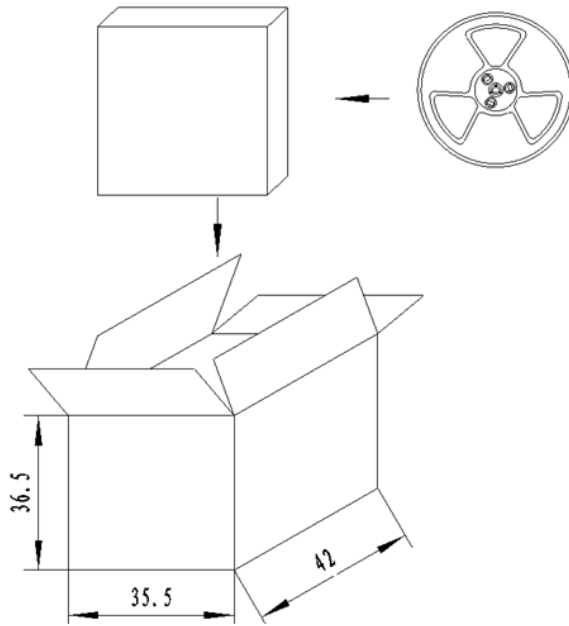

NOTES:

- 1.700 PCS per box
- 2.Total 10 boxes per carton
- 3.Total 7000 PCS carton

Specifications Revisions

Revision	Description	Date
A	Released from Engineering	11/1/2021

Note:

1. Unless otherwise specified:
 - A. All dimensions are in millimeters.
 - B. Default tolerances are $\pm 0.5\text{mm}$ and angles are $\pm 3^\circ$.
2. Specifications subject to change or withdrawal without notice.