

FRH100-00

DC-DC Converter Input Filter

Bel Power Solutions FRH100-00 Input Filter helps control EMC immunity and emission in board-level DC-DC converter applications, minimizing the conducted and radiated emissions generated by switch mode DC-DC converters.

The FRH100-00 allows board designs utilizing DC-DC converters to meet stringent EMC requirements according to railway industry standards.



Key Features & Benefits

- Ultra-Wide input voltage range: 14 -160 VDC
- Maximum operating current 8 A
- Operating ambient temperature range -40 °C to +105 °C
- Small footprint
- Meet IEC/EN 61000-4 series standards and CISPR16 / EN 55032
- Meet railway industry EN 50155 / EN 50121-3-2 and AREMA standards



Applications

- Railway related equipment

1. MODEL SELECTION

PART NUMBER	INPUT VOLTAGE RANGE [VDC]	RATED CURRENT [A]
FRH100-00	14 – 160	8

2. INPUT SPECIFICATIONS

PARAMETER	DESCRIPTION / CONDITIONS	MIN.	TYP.	MAX.	UNIT
Input Voltage Range		14	110	160	VDC
Transient Maximum Voltage	1 s	–	–	200	VDC

3. OUTPUT SPECIFICATIONS

PARAMETER	DESCRIPTION / CONDITIONS	MIN	TYP.	MAX.	UNIT
Efficiency	25 °C, 24 VDC @ 100 W	96	98	–	%
Operating Current ¹		–	–	8	A
Transient Maximum Current	10 s	–	–	10	A

¹ For operating current please refer to temperature derating curves.

4. GENERAL SPECIFICATIONS

PARAMETER	DESCRIPTION / CONDITIONS	MIN	TYP.	MAX.	UNIT
Operating Temperature		-40	–	105	°C
Storage Temperature		-55	–	125	°C
Storage Humidity		5	–	95	%RH
Withstand voltage	+Vin~ ⊕, -Vin~ ⊖, electric strength test for 1 minute with a leakage current of 5 mA max	2800	–	–	VAC
MTBF	MIL-HDBK-217F @ 25 °C	1000	–	–	kh

5. MECHANICAL SPECIFICATIONS

PARAMETER	DESCRIPTION
Case Material	Black plastic; flame-retardant and heat-resistant (UL94 V-0)
Dimension	67.0 x 37.0 x 19.8 mm
Weight	75 g (Typ.)

6. ELECTROMAGNETIC COMPATIBILITY (EN50121-3-2)

PARAMETER	DESCRIPTION	CLASS / CRITERIA	
Emission ¹	CE EN 55016-2-1	150 kHz – 500 kHz; 79 dBuV (see Fig. 4 for recommended circuit) 500 kHz – 30 MHz; 73 dBuV (see Fig. 4 for recommended circuit)	
	RE CISPR16-2-3	30 MHz – 230 MHz; 40 dBuV/m at 10 m (see Fig. 4 for recommended circuit) 230 MHz – 6 GHz; 47 dBuV/m at 10 m (see Fig. 4 for recommended circuit)	
Immunity	ESD EN 61000-4-2	Contact ± 6 kV/Air ± 8 kV	perf. Criteria A
	RS EN 61000-4-3	80 – 800 MHz; 20 V/m 800 – 1000 MHz; 20 V/m 1400 – 2000 MHz; 10 V/m 2000 – 2700 MHz; 5 V/m 5100 – 6000 MHz; 3 V/m	perf. Criteria A
	EFT EN 61000-4-4	± 2 kV; 5/50 ns; 5 kHz (see Fig. 4 for recommended circuit)	perf. Criteria A
	Surge EN 61000-4-5	Line to line ± 1 kV (42 Ω , 0.5 μ F), line to ground ± 2 kV (42 Ω , 0.5 μ F) (see Fig. 4 for recommended circuit) Line to line ± 1 kV (2 Ω , 18 μ F) line to ground ± 2 kV (12 Ω , 9 μ F) (see Fig. 4 for recommended circuit)	perf. Criteria A
	CS EN 61000-4-6	0.15 MHz – 80 MHz 10 V r.m.s	perf. Criteria A

¹ Corresponds or exceeds EN 50121-3-2

7. ELECTROMAGNETIC COMPATIBILITY (AREMA)

PARAMETER	DESCRIPTION	CLASS / CRITERIA	
Emissions	CE CISPR16-2-1 CISPR16-1-2	150 kHz – 500 kHz; 79 dBuV (see Fig. 4 for recommended circuit) 500 kHz – 30 MHz; 73 dBuV (see Fig. 4 for recommended circuit)	CLASS A
	RE CISPR16-2-3	30 MHz – 230 MHz; 40 dBuV/m at 10 m (see Fig. 4 for recommended circuit) 230 MHz – 1 GHz; 47 dBuV/m at 10 m (see Fig. 4 for recommended circuit)	CLASS A
Immunity	ESD IEC 61000-4-2	Contact ± 6 kV/Air ± 8 kV	perf. Criteria A
	RS IEC 61000-4-3	80 – 1000 MHz; 10 V/m 160 – 165 MHz; 20 V/m 450 – 470 MHz; 20 V/m 800 – 960 MHz; 20 V/m 1400 – 2000 MHz; 20 V/m 2100 – 2500 MHz; 5 V/m	perf. Criteria A
	EFT IEC 61000-4-4	± 2 kV 5/50 ns; 5 kHz (see Fig. 4 for recommended circuit)	perf. Criteria A
	Surge IEC 61000-4-5	Line to line ± 2 kV (2 Ω , 18 μ F); line to ground ± 2 kV (2 Ω , 18 μ F) (see Fig. 4 for recommended circuit)	perf. Criteria A
	CS IEC 61000-4-6	0.15 MHz-80 MHz; 10 V r.m.s	perf. Criteria A
	MS IEC 61000-4-8 IEC 61000-4-8	60 Hz; 100 A/m (see Fig. 4 for recommended circuit) 60 Hz; 300 A/m (see Fig. 4 for recommended circuit)	perf. Criteria A

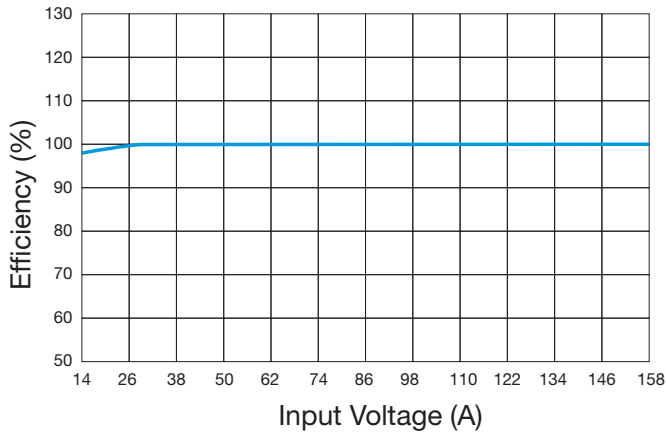

Figure 1. Efficiency vs. Input Voltage (Full Load)

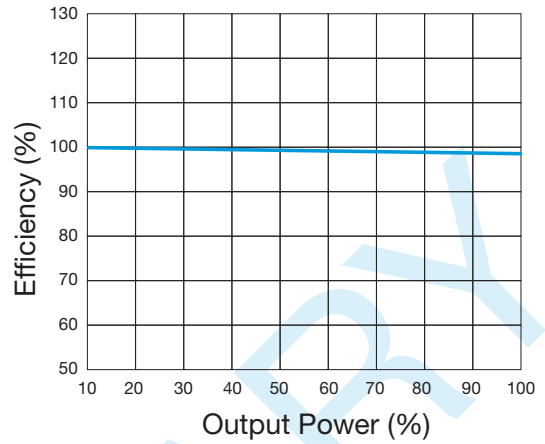

Figure 2. Efficiency vs. Output Load (Vin = 110 V)

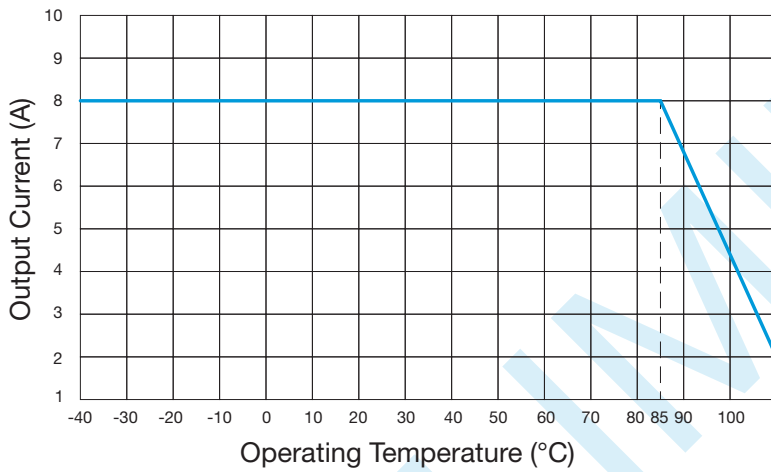

Figure 3. Temperature Derating vs. Output Current

8. DESIGN REFERENCE

TYPICAL APPLICATION

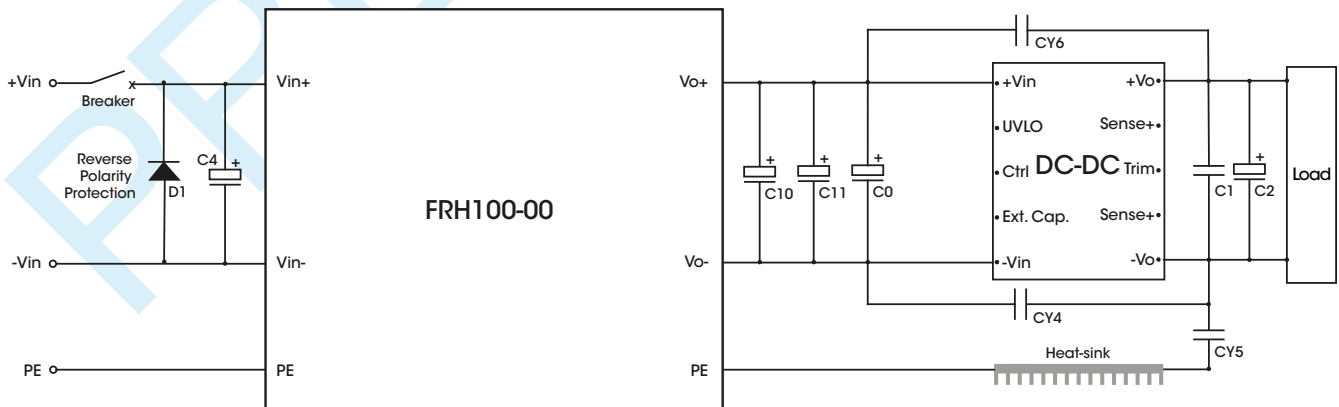

Figure 4. Typical Application

COMPONENTS	VALUE	RECOMMENDED COMPONENT
C1	1 μ F	CERAMIC; 1 μ F; 10%; 100 V; X7R; 1206; -55 to +125°C
C2	330 μ F	ELECTROLYTIC; Al,WET; RADIAL; 330 μ F; 20%; 63 V; \varnothing 10 x 20 mm; PITCH 5 mm; -40 to +105°C
C4	560 μ F	ELECTROLYTIC; Al,WET; RADIAL; 560 μ F; 20%; 200 V; \varnothing 18 x 45 mm; PITCH 7.5 mm; -40 to +105°C
CY4, CY5, CY6	3.3 nF	CERAMIC; X1/Y1; 3.3 nF; 20%; 400 V; PITCH 10 mm; -40 to +125°C
D1	20 A	SCHOTTKY; DUAL; 200 V; 2x 20 A; Vf 0.95 V; TO220; -55 to +150°C; COMMON CATHODE
Fuse or Breaker ¹	15 A	Type C

¹ Type of fuse / circuit breaker can be selected according to the actual application. The specification value must be greater than the maximum input working current and less than the rated working current of the anti-reverse polarity diode.

SURGE STANDARD	COMPONENTS	VALUE	RECOMMENDED COMPONENT
line to line \pm 1 kV (42 Ω , 0.5 μ F) line to ground \pm 2 kV (42 Ω , 0.5 μ F)	C0	100 μ F	ELECTROLYTIC; Al,WET; RADIAL; 100 μ F; 20%; 250 V; \varnothing 16 x 20 mm; PITCH 7.5 mm; -40 to +105°C
	C10, C11	—	—
line to line \pm 1 kV (2 Ω , 18 μ F) line to ground \pm 2 kV (12 Ω , 9 μ F)	C0, C10	100 μ F	ELECTROLYTIC; Al,WET; RADIAL; 100 μ F; 20%; 250 V; \varnothing 16 x 20 mm; PITCH 7.5 mm; -40 to +105°C
	C11	—	—
line to line \pm 2 kV (2 Ω , 18 μ F) line to ground \pm 2 kV (2 Ω , 18 μ F)	C0, C10, C11	100 μ F	ELECTROLYTIC; Al,WET; RADIAL; 100 μ F; 20%; 250 V; \varnothing 16 x 20 mm; PITCH 7.5 mm; -40 to +105°C

9. MECHANICAL SPECIFICATIONS

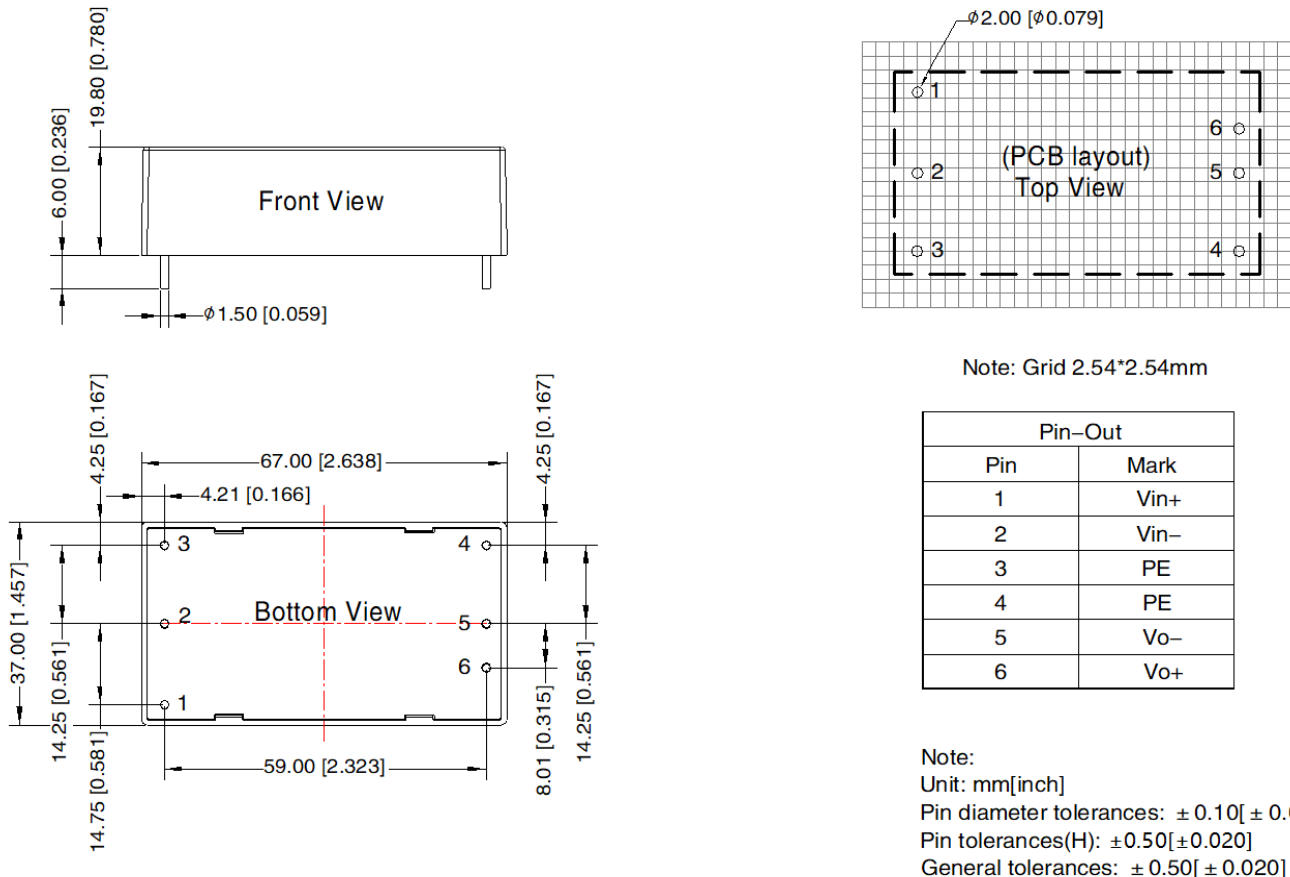

Figure 5. Mechanical drawing

For more information on these products consult: tech.support@psbel.com

NUCLEAR AND MEDICAL APPLICATIONS - Products are not designed or intended for use as critical components in life support systems, equipment used in hazardous environments, or nuclear control systems.

TECHNICAL REVISIONS - The appearance of products, including safety agency certifications pictured on labels, may change depending on the date manufactured. Specifications are subject to change without notice.