

User's Guide

INA220EVM (Rev C)



Precision Linear Products

ABSTRACT

This user's guide describes the characteristics, operation, and use of the INA220 evaluation module (Rev C) hardware. The document covers all pertinent areas involved to properly use this EVM board. Throughout this document, the terms *evaluation board*, *evaluation module*, and *EVM* are synonymous with the INA220EVM. This document includes the physical printed circuit board layout, schematic diagrams, and circuit descriptions.

Table of Contents

1 Overview	2
1.1 INA220EVM Hardware.....	2
1.2 Related Documentation from Texas Instruments.....	3
1.3 Information About Cautions and Warnings.....	4
2 System Setup	5
2.1 Theory of Operation for INA220_Test_Board Hardware.....	5
2.2 Signal Definitions of J1 (25-Pin Male DSUB).....	7
2.3 Theory of Operation For USB_DIG_Platform.....	8
3 INA220EVM (Rev C) Hardware Setup	9
3.1 Electrostatic Discharge Warning.....	9
3.2 Typical Hardware Connections.....	9
3.3 Connecting the Hardware.....	10
3.4 Connecting Power.....	10
3.5 Connecting the USB Cable to the INA220EVM.....	11
3.6 INA220 Jumper Settings.....	12
3.7 Connecting External Power to the INA220EVM.....	15
3.8 Connecting External Signals to the INA220EVM.....	15
4 INA220 Software Overview	16
4.1 INA220EVM Software Install.....	16
4.2 Starting the INA220EVM Software.....	16
4.3 Using the INA220 Software.....	19
5 Bill of Materials	21
6 Revision History	22

Trademarks

Microsoft® and Windows® are registered trademarks of Microsoft Corporation.
All trademarks are the property of their respective owners.

1 Overview

This document provides the information needed to set up and operate the INA220EVM evaluation module, a test platform for the [INA220](#), a high or low side, bidirectional current and power monitor with an I²C interface. For a more detailed description of the INA220, see also the product [data sheet](#) available from the Texas Instruments website at <http://www.ti.com>. Additional support documents are listed in the section of this guide entitled [Related Documentation from Texas Instruments](#).

The INA220EVM is an evaluation module used to fully evaluate the INA220 current and power monitor device. The INA220EVM consists of two printed circuit boards (PCBs). One board (the USB DIG Platform) generates the digital signals required to communicate with the INA220, which is part of the second board (INA220_Test_Board), as well as support and configuration circuitry.

Throughout this document, the abbreviation *EVM* and the term *evaluation module* are synonymous with the INA220EVM.

Note

Much of the information contained in this user's guide is also presented in a quick-start video ([SBOU296](#)), available for download from the [INA220 product folder](#). TI recommends watching the SBOI296 video.

1.1 INA220EVM Hardware

[Figure 1-1](#) shows the hardware included with the INA220EVM kit. Contact the [Texas Instruments customer support center](#) if any component is missing. TI recommends users check the TI website at <http://www.ti.com> to verify that they have the latest versions of the related software.

The complete kit includes the following items:

- INA220 test PCB
- USB DIG platform PCB
- USB cable
- Barrel plug cable assembly (part# 10-01935/ Tensility Intl Corp.) for external power supply to USB DIG and optionally to EVM
- CD-ROM containing this user's guide, product software, and a demonstration video

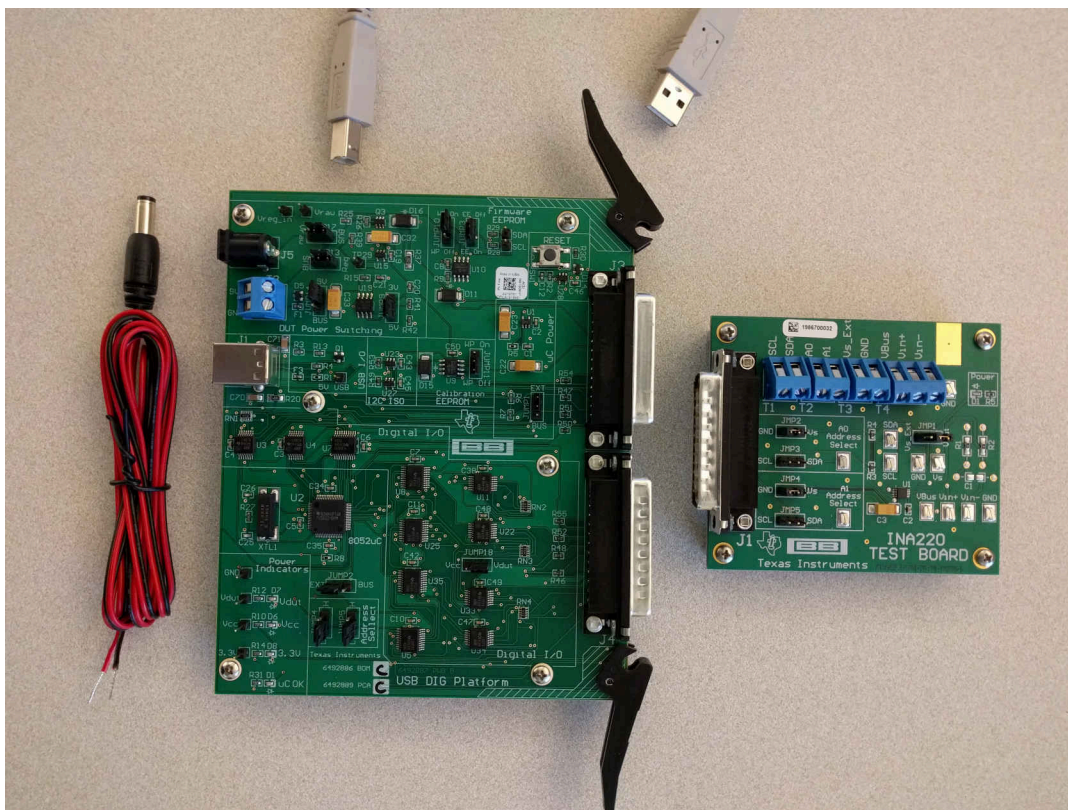

Figure 1-1. Hardware Included with the INA220EVM

1.2 Related Documentation from Texas Instruments

The following document provides information regarding Texas Instruments integrated circuits used in the assembly of the INA220EVM. This user's guide is available from the TI website under literature number *SBOU079*. Any letter appended to the literature number corresponds to the document revision that is current at the time of the writing of this document. Newer revisions may be available from the TI website at <http://www.ti.com/>, or call the Texas Instruments Literature Response Center at (800) 477-8924 or the Product Information Center at (972) 644-5580. When ordering, identify the document by both title and literature number.

DOCUMENT	LITERATURE NUMBER
INA220 Product Data Sheet	SBOS459
USB DIG Platform Users Guide	SBOU058

1.3 Information About Cautions and Warnings

This document contains caution statements.

CAUTION

This is an example of a caution statement. A caution statement describes a situation that can potentially damage your software or equipment.

The information in a caution or a warning is provided for your protection. Remember to read each caution statement carefully.

2 System Setup

Figure 2-1 shows the system setup for the INA220EVM. The PC runs software that communicates with the USB DIG Platform. The USB DIG Platform generates the analog and digital signals used to communicate with the INA220_Test_Board. Users can connect the INA220_Test_Board to the system and monitor the power, current, and voltage of the system under test conditions.

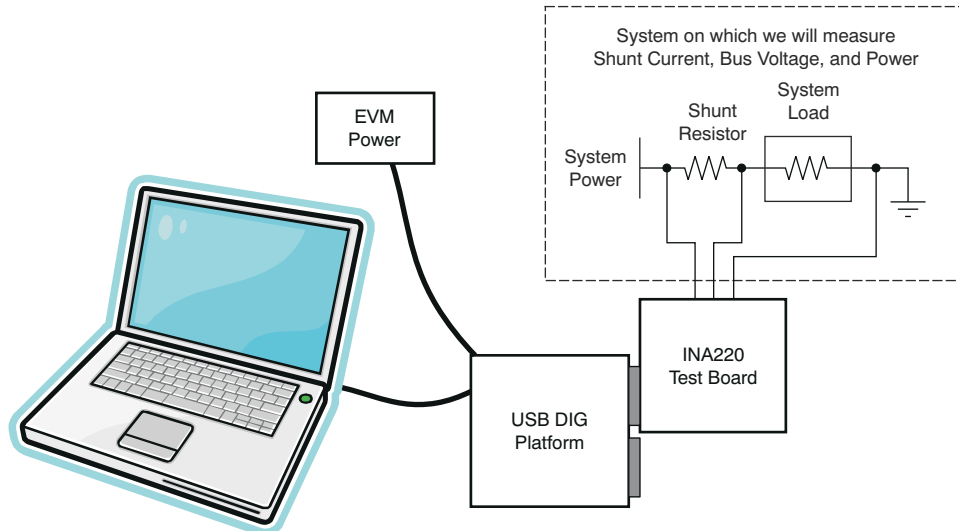

Figure 2-1. INA220EVM Hardware Setup

2.1 Theory of Operation for INA220_Test_Board Hardware

Figure 2-2 shows a block diagram of the INA220_Test_Board. The printed circuit board (PCB) provides connections to the I²C interface and general-purpose input and outputs (GPIO) on the USB DIG Platform board. The PCB also provides connection points for external connections of the shunt voltage, bus voltage, and GND.

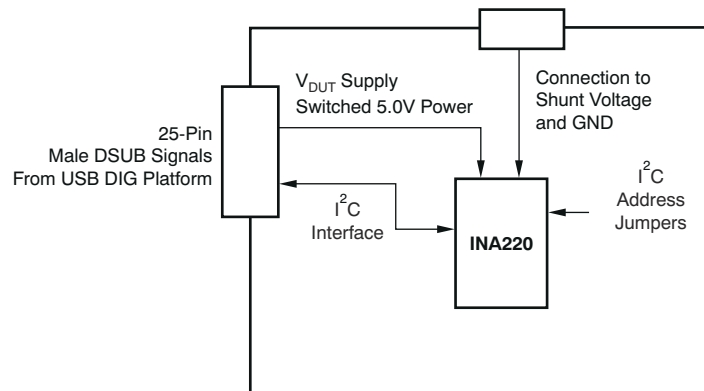

Figure 2-2. INA220_Test_Board Block Diagram

Figure 2-3 shows the system setup for the INA220_Test_Board schematic. D1 is an LED that indicates whether the INA220 Test Board is receiving power. Jumpers allow the selection of the power source as well as configuration of A0 and A1. Connector T4 allows the connection of the shunt and bus voltages.

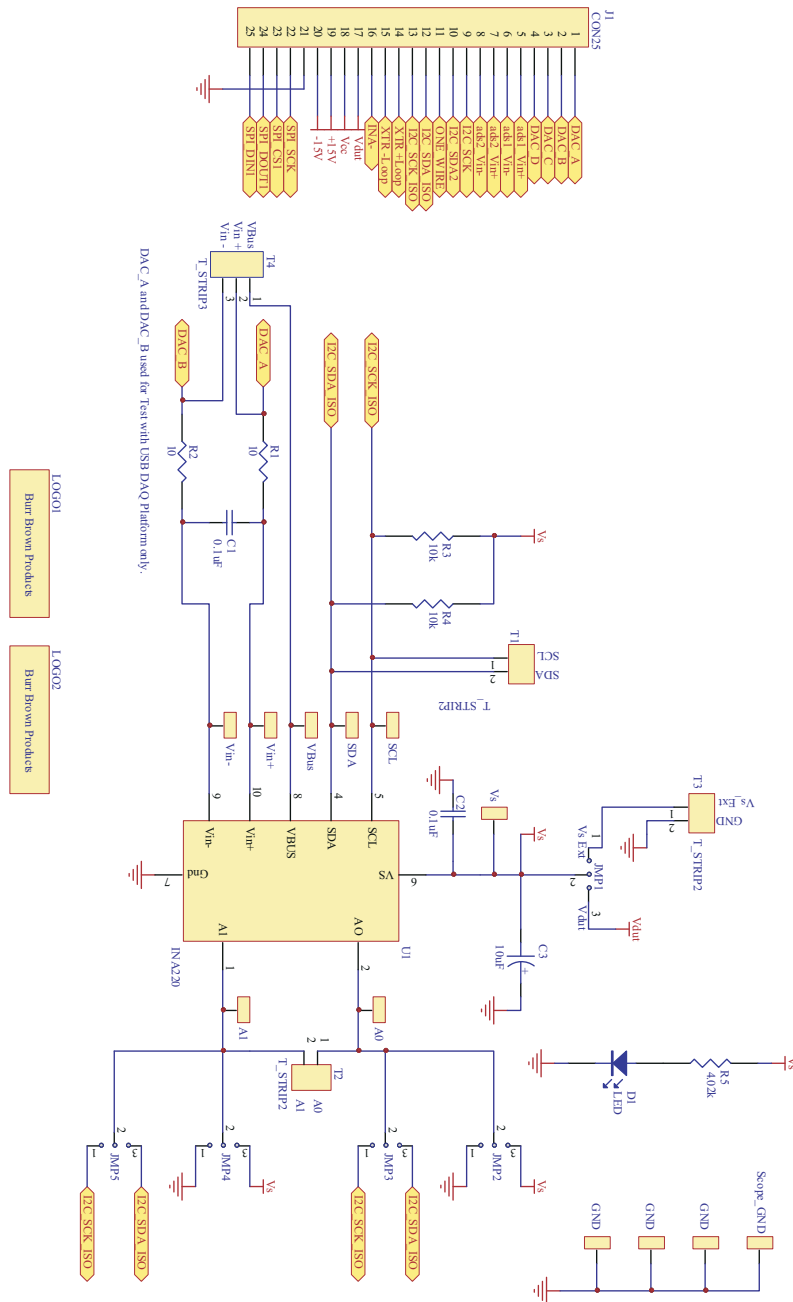

Figure 2-3. INA220_Test_Board Schematic

2.2 Signal Definitions of J1 (25-Pin Male DSUB)

Table 2-1 lists the different signals connected to J1 on the INA220_Test_Board. This table also lists the signals connected to pins on J1 that are not used on the INA220_Test_Board.

Table 2-1. Signal Definition of J1 (25-Pin Male DSUB) on INA220_Test_Board

J1 PIN	SIGNAL	INA220 PIN
1	NC	No connection
2	NC	No connection
3	NC	No connection
4	NC	No connection
5	NC	No connection
6	NC	No connection
7	NC	No connection
8	NC	No connection
9	I2C_SCK	No connection
10	I2C_SDA2	No connection
11	NC	No connection
12	I2C_SCK_ISO	I ² C clock signal (SCL) channel 1; can be disconnected using a switch
13	I2C_SDA_ISO	I ² C data signal (SDA) channel 1; can be disconnected using a switch
14	NC	No connection
15	NC	No connection
16	NC	No connection
17	V _{DUT}	Switched 3-V or 5-V power. Note that when power is switched off, the digital I/O is also switched off.
18	V _{CC}	No connection
19	NC	No connection
20	NC	No connection
21	GND	Common or ground connection for power
22	SPI_SCK	No connection
23	SPI_CS1	No connection
24	SPI_DOUT	No connection
25	SPI_DIN1	No connection

2.3 Theory of Operation For USB_DIG_Platform

Figure 2-4 shows the block diagram for the USB DIG Platform. This platform is a general-purpose data acquisition system used on other Texas Instruments evaluation modules. The details of the USB DIG Platform operation are included in a [separate document](#) (available for download at www.ti.com). The block diagram shown in Figure 2-4 gives a brief overview of the platform. The TUSB3210 is the primary control device for the USB DIG Platform.

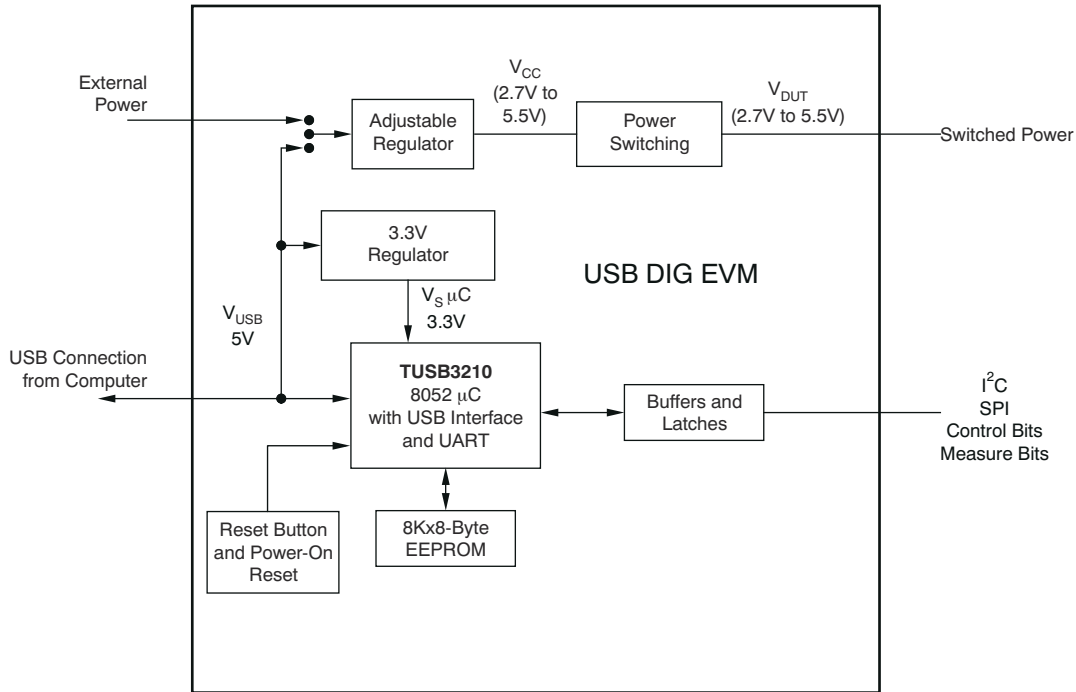

Figure 2-4. USB_DIG_Platform Theory of Operation

The USB DIG can provide power to the EVM PCB. As depicted in Figure 2-4, switched power for the EVM can be derived from the USB supply of the PCB or from an external power source connected to J5. TI recommends using the external supply option because the USB power supply can be noisy. The barrel connector cable assembly included in the EVM kit can connect an external power supply to the USB DIG. Connect the black wire of the cable assembly to the low side (or ground) of the external supply and the red wire to the high side.

Note

For proper operation, the external source must provide a supply voltage between 5.8 V and 10.4 V and have a current limit greater than 100 mA.

3 INA220EVM (Rev C) Hardware Setup

The INA220EVM (Rev C) hardware setup involves connecting the two PCBs of the EVM together, applying power, connecting the USB cable, and setting the jumpers. This section details this procedure.

3.1 Electrostatic Discharge Warning

Many of the components on the INA220EVM are susceptible to damage by electrostatic discharge (ESD). Customers are advised to observe proper ESD handling precautions when unpacking and handling the EVM, including the use of a grounded wrist strap at an approved ESD workstation.

CAUTION

Failure to observe ESD handling procedures may result in damage to EVM components.

3.2 Typical Hardware Connections

The INA220EVM hardware setup involves connecting the two PCBs of the EVM together, applying power, and connecting an external shunt and load. The external connections may be the real-world system that the INA220 will be incorporated into. [Figure 3-1](#) shows the typical hardware connections.

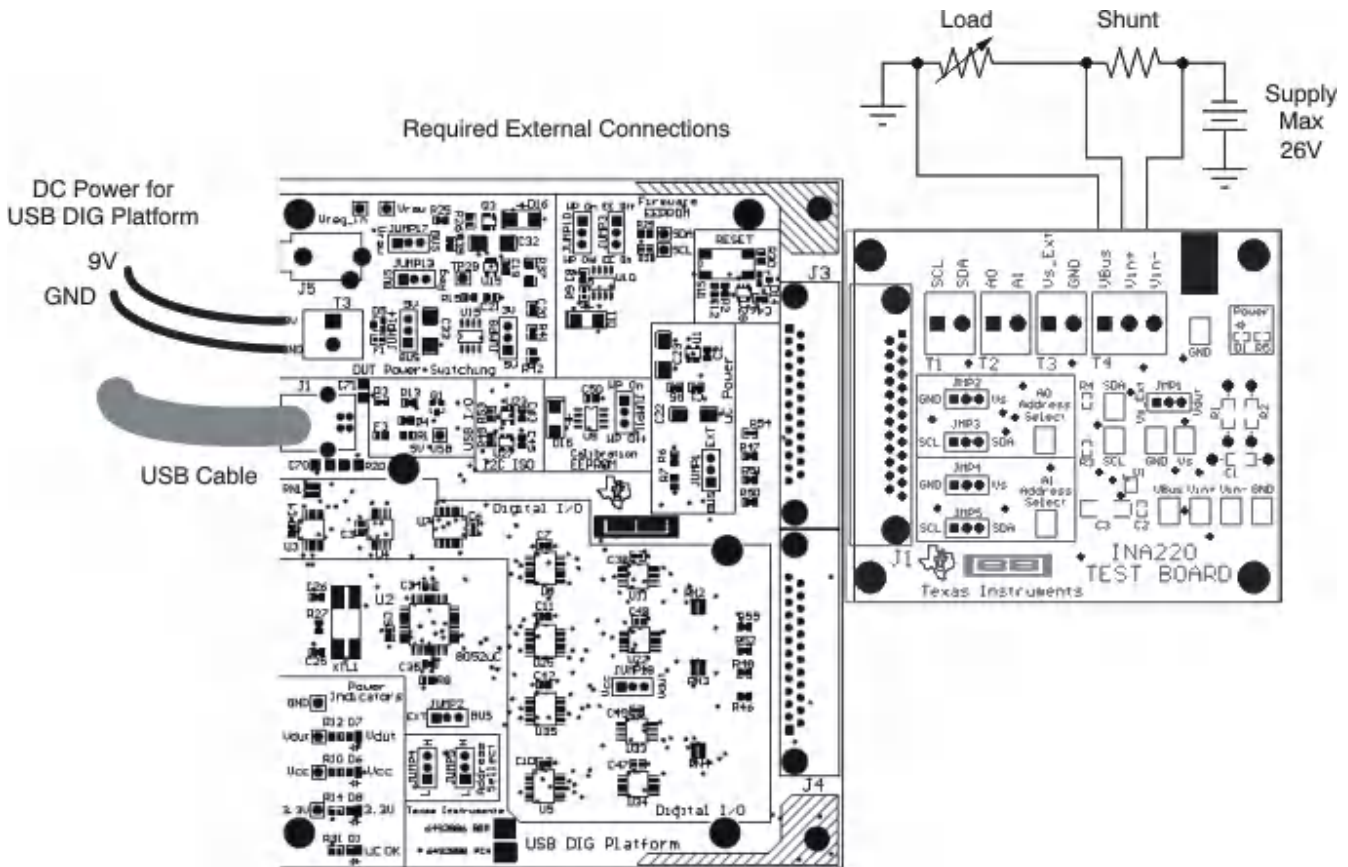

Figure 3-1. Typical Hardware Connections

3.3 Connecting the Hardware

To connect the two PCBs of the INA220EVM together, gently push on both sides of the D-SUB connectors (as shown in [Figure 3-2](#)). Ensure the two connectors are completely pushed together; loose connections may cause intermittent operation.

3.4 Connecting Power

After the two PCBs of the INA220 EVM are connected, as [Figure 3-2](#) shows, connect the power to the EVM. Always connect power before connecting the USB cable. If the USB cable is connected before the power, the computer will attempt to communicate with an unpowered and unresponsive device

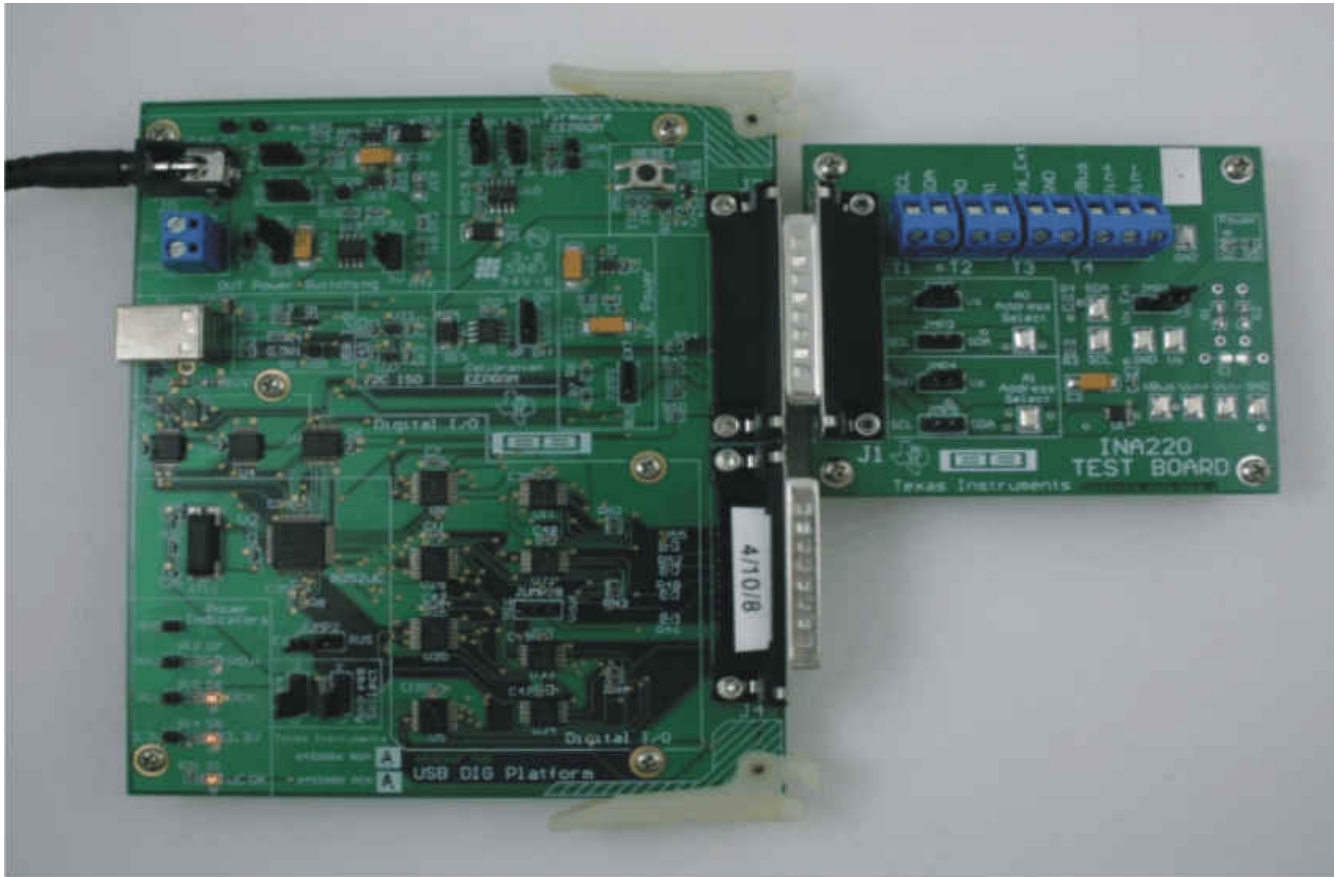
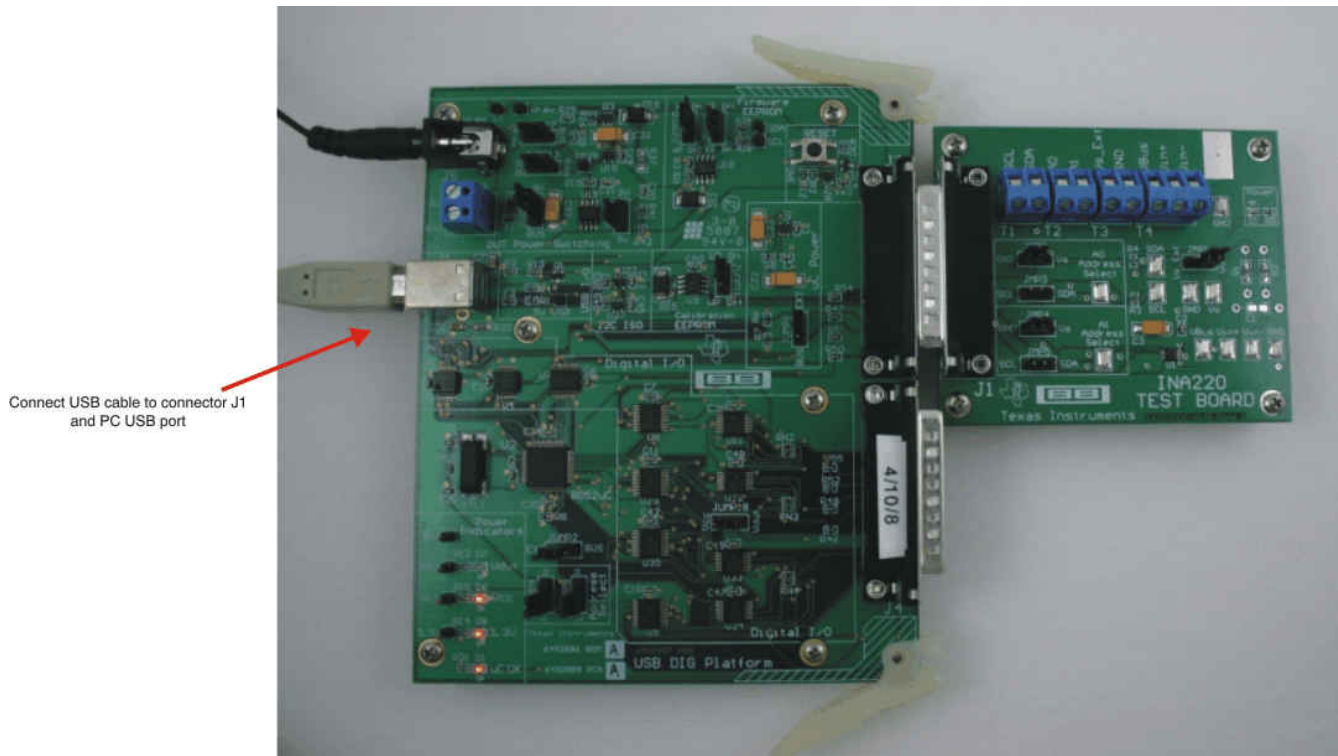

Figure 3-2. Connecting Power to the EVM

3.5 Connecting the USB Cable to the INA220EVM

Figure 3-3 shows the typical response to connecting the USB DIG platform to a PC USB port for the first time. Note that the EVM must be powered on before connecting the USB cable. Typically, the computer will respond with a *Found New Hardware, USB Device* pop-up. The pop-up typically changes to *Found New Hardware, USB Human Interface Device*. This pop-up indicates that the device is ready for use. The USB DIG platform uses the *Human Interface Device Drivers* that are part of the Microsoft® Windows® operating system.

In some cases, the Windows *Add Hardware Wizard* will pop up. If this prompt occurs, click *Yes* to allow the system device manager to install the Human Interface Drivers.



The first time that a USB DIG platform board is plugged into the PC, the following messages may be displayed:



Figure 3-3. Connecting the USB Cable

3.6 INA220 Jumper Settings

Figure 3-4 shows the default jumpers configuration for the INA220EVM. In general, the jumper settings of the USB DIG Platform will not need to be changed, but you may want to change some of the jumpers on the INA220_Test_Board to match your specific configuration. For instance, you may wish to set a specific I²C address.

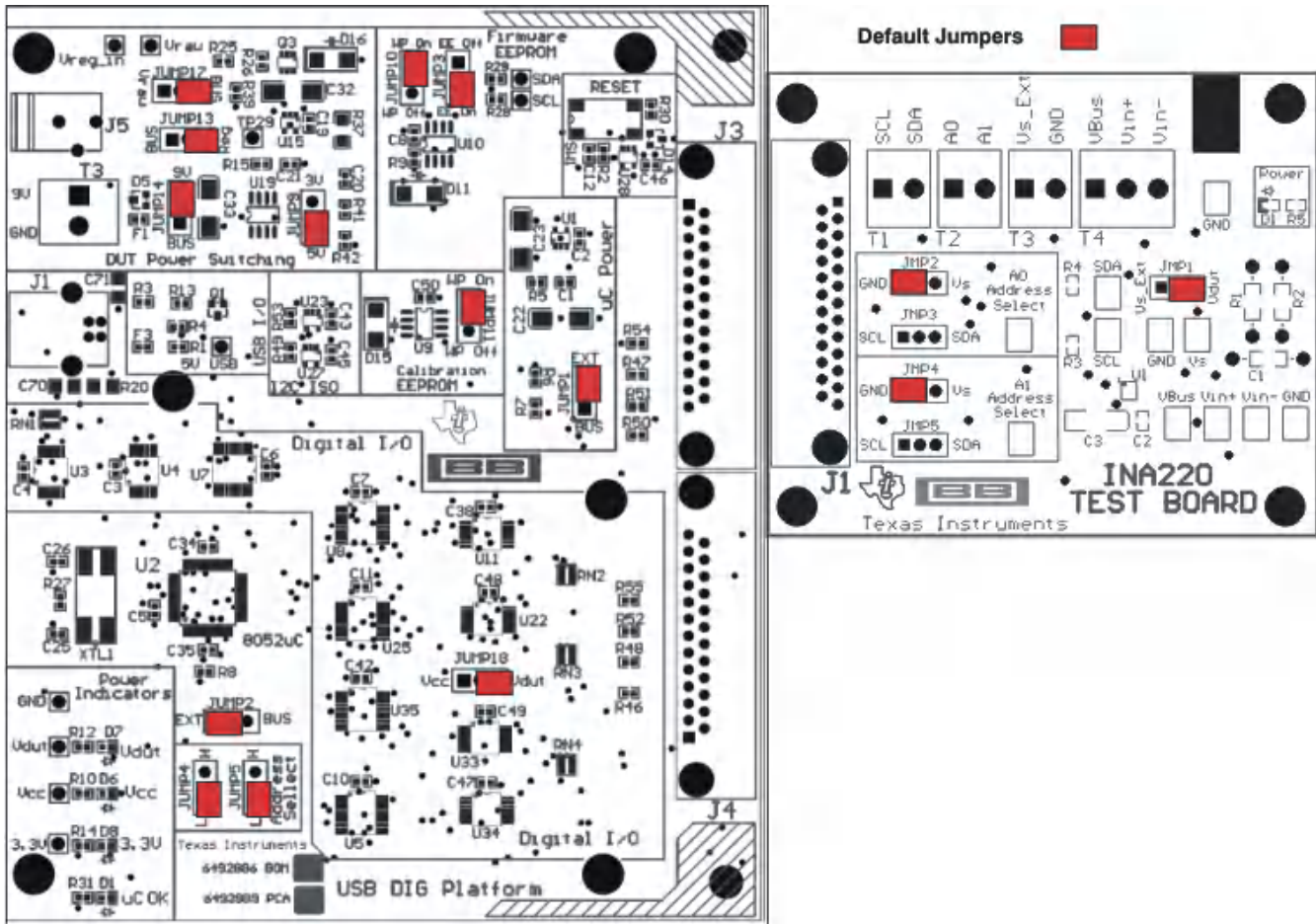

Figure 3-4. INA220EVM Default Jumper Settings

Table 3-1 explains the function of the jumpers on the INA220_Test_Board.

Table 3-1. INA220_Test_Board Jumper Functions

JUMPER	DEFAULT	PURPOSE
JMP1	V _{DUT}	This jumper determines the source for the INA220 power supply. In the <i>V_{dut}</i> position, the USB DIG board supplies the power to the INA220. In the <i>V_{s_Ext}</i> position, an external supply connected to the INA220 T3 terminal supplies power.
JMP2, JMP3	JMP2 (GND)	A0 address input selection. This jumper determines which signal is connected to the A0 pin of the INA220.
JMP4, JMP5	JMP4 (GND)	A1 address input selection. This jumper determines which signal is connected to the A1 pin of the INA220.

Table 3-2 summarizes the function of the USB DIG platform jumpers. For most applications, the default jumper position will be used. Table 3-3 and Table 3-4 describe the options for the power-supply configuration. For example, the logic power supply can be changed from the default of 5 V to 3 V. A separate document (SBOU058) details the operation and design of the USB DIG platform.

Table 3-2. USB DIG Platform Jumper Settings

JUMPER	DEFAULT	PURPOSE
JUMP1	EXT	This jumper selects external power or bus power. External power is applied on J5 (on USB DIG board) or T3 (9 V _{DC}). Bus power is 5 V from the USB. External power is typically used because the USB power is noisy.
JUMP2	EXT	Same as JUMP1.
JUMP3	EE ON	This jumper determines where the TUSB3210 will load the USB DIG Platform firmware upon power-up or reset. The <i>EE Off</i> position is used for development for development or firmware updates.
JUMP4, JUMP5	L, L	This jumper sets the address for the USB board. Only change from the default setting if using multiple boards.
JUMP9	5 V	This jumper selects the voltage of the device under test supply (V _{DUT} = 5 V or 3 V). This jumper is typically the only jumper that is changed for most applications.
JUMP10	WP ON	This jumper write-protects the firmware EEPROM.
JUMP11	WP ON	This jumper write-protects the calibration EEPROM.
JUMP13	Reg	This jumper uses the regulator output to generate the V _{DUT} supply. The USB can be used as the V _{DUT} supply.
JUMP14	9 V	This jumper uses the external power (9 V as apposed to the bus)
JUMP17	BUS	While in the BUS position, V _{DUT} operation is normal. While in the V _{RAW} position, the V _{DUT} supply is connected to an external source. This flexibility allows for any value of V _{DUT} between 3 V and 5 V. <div style="border: 1px solid black; padding: 5px; text-align: center;"> <p>CAUTION</p> <p>When JUMP17 is in the V_{RAW} position, adjusting the V_{DUT} voltage beyond the 3 V to 5 V range will damage the EVM.</p> </div>
JUMP18	V _{DUT}	This jumper connects the pullup on the GPIO to the V _{DUT} supply or the V _{CC} supply.

Table 3-3. Power-Supply Jumper Configuration #1

MODE	JUMPER	COMMENT
External Power—5V (default jumper settings)	JUMP17 = BUS (not used) JUMP13 = REG JUMP14 = 9 V JUMP1 = EXT JUMP2 = EXT JUMP6 = 5 V JUMP7 = REF	In this mode, all power is supplied to the EVM by J5 (on USB DIG board) or T3. The external supply must be between 5.8 V and 10.4 V for proper operation. All digital I/Os are regulated to 5 V using U19 (REG101).
External Power—3V (typical jumper settings)	JUMP17 = BUS (not used) JUMP13 = REG JUMP14 = 9 V JUMP1 = EXT JUMP2 = EXT JUMP6 = 3 V JUMP7 = REF	In this mode, all power is supplied to the EVM by J5 (on USB DIG board) or T3. The external supply must be between 5.8 V and 10.4 V for proper operation. All digital I/Os are regulated to 3 V using U19 (REG101).
External Power—Variable Supply	JUMP17 = Vraw JUMP13 = BUS JUMP14 = 9 V (not used) JUMP1 = EXT JUMP2 = EXT JUMP6 = 5 V (not used) JUMP7 = REG (ratiometric mode)	<p>In this mode, all the digital I/Os are referenced to the supply that is attached to either J5 (on USB DIG board) or T3.</p> <div style="border: 1px solid black; padding: 5px; text-align: center;"> <p>CAUTION</p> <p>It is absolutely critical that the supply voltage does not exceed 5.5 V in this mode.</p> </div> <p>The supply is directly applied to devices with 5.5 V absolute maximum ratings. This mode of operation is useful when a device supply other than 3.0 V or 5.0 V is required.</p>

Table 3-4. Power-Supply Jumper Configuration #2

MODE	JUMPER	COMMENT
Bus Power—5V	JUMP17 = BUS JUMP13 = BUS JUMP14 = 9 V (not used) JUMP1 = BUS JUMP2 = BUS JUMP6 = 5 V (not used) JUMP7 = REG (ratiometric mode, 5-V supply)	In this mode, the USB bus completely powers the EVM. The USB bus is regulated by the controller (computer) to be 5 V. This mode relies upon external regulation. This mode is recommended only when an external 9-V supply is not available. If an external 9-V supply is available, use either <i>External Power—5V</i> mode or <i>External Power—3V</i> mode.
Bus Power—3V	JUMP17 = BUS (not used) JUMP13 = REG JUMP14 = BUS JUMP1 = BUS JUMP2 = BUS JUMP6 = 3 V JUMP7 = REG (ratiometric mode, 5-V supply)	In this mode, the USB bus completely powers the EVM. The regulator (U19, REG101) generates a 3-V supply for all digital I/O.

3.7 Connecting External Power to the INA220EVM

The INA220 power supply (V_S) operates in the range of 3 V to 5.5 V (see the [INA220 product data sheet](#)). The default jumper position provides 5 V to the INA220 from the USB-DIG-Platform. The power from the USB-DIG-Platform can be changed to 3 V using JUMP9.

Another option is to connect power to the INA220 power supply (V_S) using an external power supply. In this case, connect power to the T3 terminal block and set JMP1 to the V_S_EXT position. The INA220 power supply (V_S) operates in the range of 3 V to 5.5 V; do not operate outside of this range.

3.8 Connecting External Signals to the INA220EVM

The INA220 shunt and bus voltages are applied through the terminal block T4. The T4 terminal block is a direct connection to V_{IN+} and V_{IN-} of the INA220. The bus voltage is monitored on V_{BUS} (26 V maximum). The shunt voltage is the difference between V_{IN-} and V_{IN+} (320 mV maximum). See also the [INA220 data sheet](#).

4 INA220 Software Overview

This section discusses the installation and operation of the INA220 software.

4.1 INA220EVM Software Install

Follow these steps to install the INA220EVM software:

1. Software can be downloaded from the [INA220EVM](#) web page, or from the disk included with the INA220EVM, which contains a folder called *Install_software/*.
2. Find the file called *setup.exe*. Double-click the file to start the installation process.
3. Follow the on-screen prompts to install the software.
4. To remove the application, use the Windows Control Panel utility, *Add/Remove Software*.

The [INA220 Quick-Start Video](#) (included with the kit, or available for download in the INA220 product folder) details the initialization of the software.

4.2 Starting the INA220EVM Software

The INA220 software can be operated through the Windows *Start* menu. From *Start*, select *All Programs*; then select the *INA220EVM* program. [Figure 4-1](#) shows how the software will appear if the EVM is functioning properly.

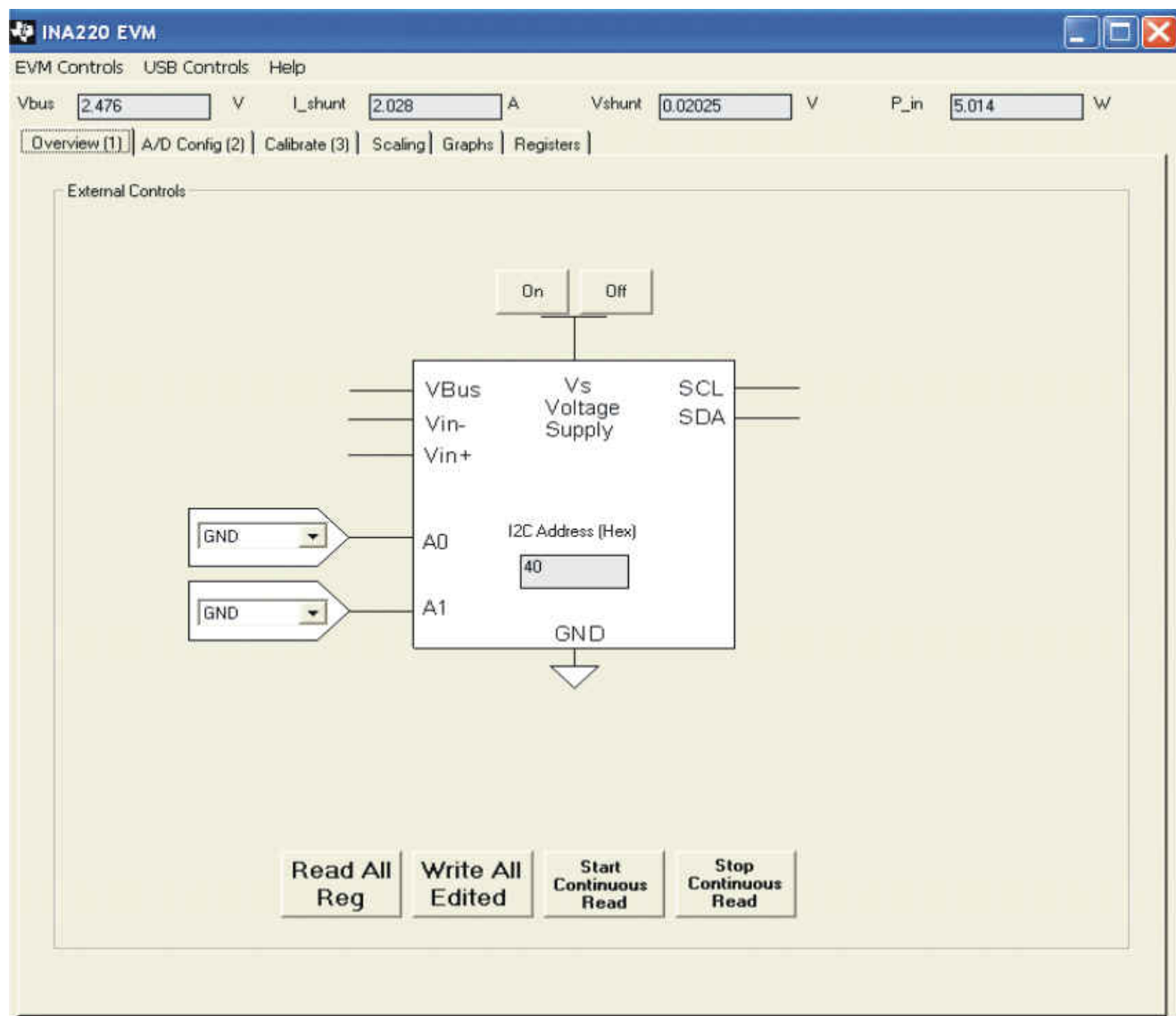

Figure 4-1. INA220EVM Software—Functioning Properly

Figure 4-2 shows an error that pops up if the computer cannot communicate with the EVM. If you receive this error, first check to see that the USB cable is properly connected. This error can also occur if you connect the USB cable before the USB DIG Platform 9-V power source. Another reason for this error is that there may be an issue with the computer USB Human Interface Device Driver. Make sure that when you plug the in the USB cable, the computer recognizes the device. If the sound is on, you will hear the distinctive sound that you expect when a USB device is properly connected to the PC.



Figure 4-2. INA220EVM Software—No Communication with the USB DIG Platform

Figure 4-3 shows an error that occurs if the INA220_Test_Board is not communicating with the USB DIG Platform. If you see this error, check the connectors between the two boards; make sure the 25-pin connectors are completely pushed together. Also make sure the INA220_Test_Board jumpers are set in the right position.

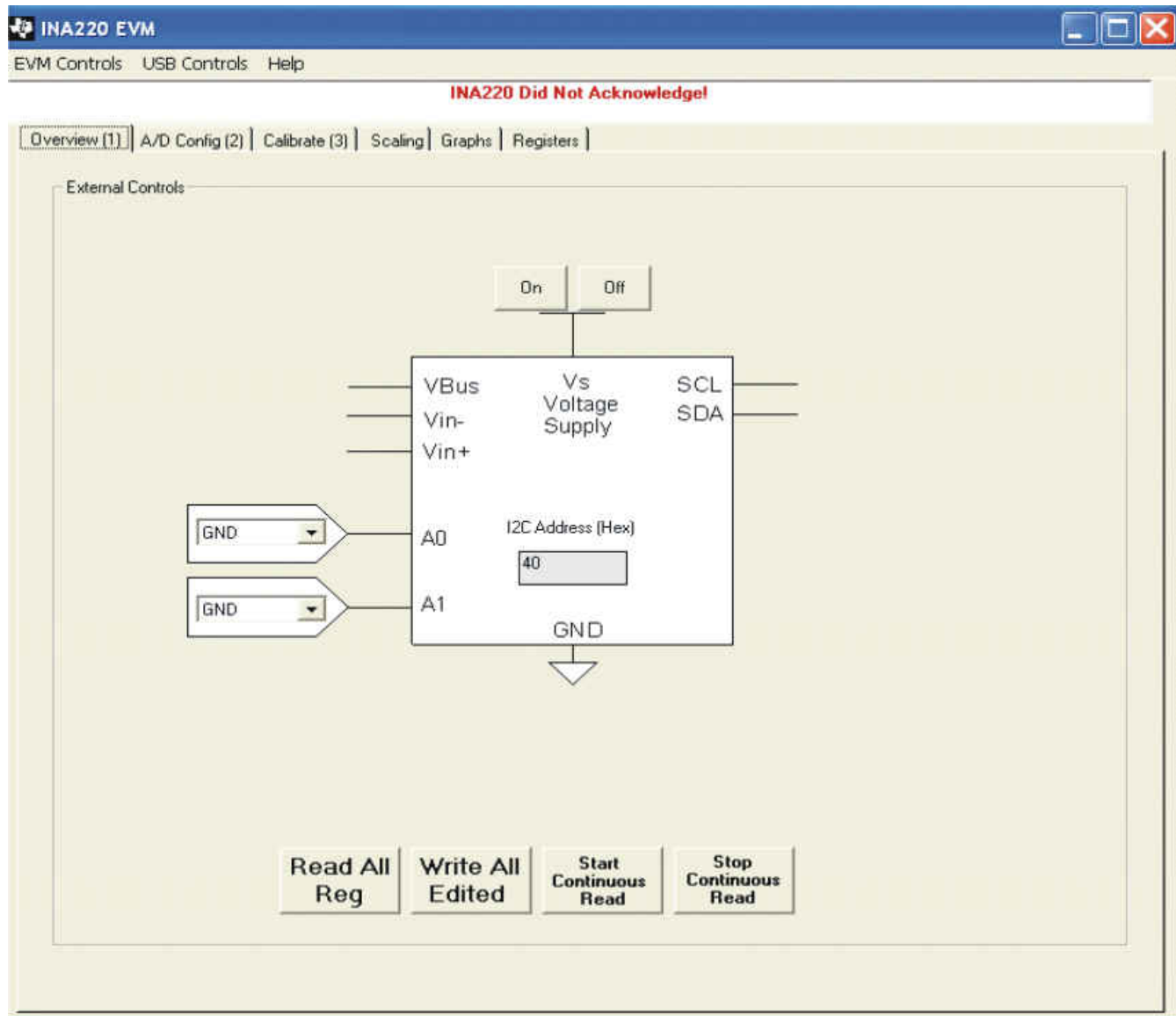

Figure 4-3. INA220EVM Software—No Communication with the USB DIG Platform and INA220

4.3 Using the INA220 Software

The INA220EVM software has six different tabs that allow access to the different features of the INA220. The first four tabs are designed to allow for complete configuration of the device by stepping through the tabs in order. Each tab is intended to have an intuitive graphical interface that fosters a better understanding of the device.

4.3.1 Overview Tab

The Overview tab has the following controls:

- Turn the power supply on and off
- Set the I²C address

4.3.2 Config Tab

The Config tab has the following controls:

- Shunt voltage attenuator range (smallest range: 40 mV; largest range: 320 mV)
- Shunt voltage configuration: resolution and number of averages. Note that increasing the number of averages decreases the noise but slows down the conversion rate.
- Bus voltage attenuator range (16 V and 32 V): Note that the maximum bus voltage for the INA220 is 26 V. Thus, the 32V range cannot be fully used.
- Bus voltage configuration: Resolution and number of averages. Note that increasing the number of averages decreases noise but slows down the conversion rate.
- A/D converter mode: This control determines how the converters work. The most commonly used modes are Shunt and Bus continuous conversion mode. This mode causes both converters to run continuously.

More details on these options are explained in the [product data sheet](#).

4.3.3 Calibration Tab

The Calibration tab allows users to enter some information regarding the INA220 configuration in a given application. This information is used to compute the Full-Scale Cal Register. The Full-Scale Cal Register converts the shunt voltage to a current value. The detailed mathematics behind this calibration feature is given in the [INA220 data sheet](#). Also, this feature is explained in a step-by-step manner in the video.

4.3.4 Scaling Tab

The Scaling tab allows you to see how the mathematical operations work in the INA220. Specifically, this tab shows how the current and power values are computed using the full-scale calibration register.

4.3.5 Graph Tab

The Graph tab will display bus voltage, shunt current, and power versus time when the software is in continuous convert mode.

4.3.6 Registers Tab

The Registers tab allows you to read and edit all the registers in the INA220. All the previous tabs affect the register listing. For example, changing the A/D configuration on Tab 2 will affect Register 0 in the register list. It is also true that changing register 0 updates the A/D configuration on Tab 2. Thus, the graphical representation and register representation affect each other.

4.3.7 EVM Controls Pull-Down Menu

The INA220 configuration (register settings) can be saved or loaded using the *EVM Controls* drop-down menu, as [Figure 4-4](#) shows. The file that the configuration is saved into is a simple text file and can be viewed with any text editor.

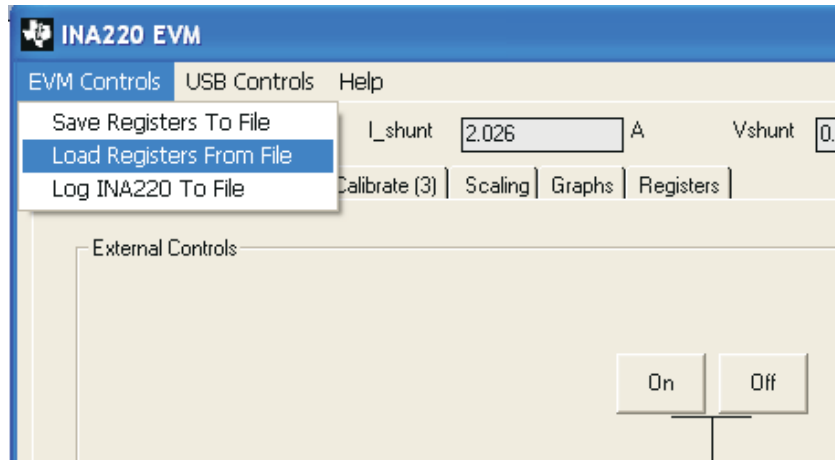

Figure 4-4. EVM Controls Drop-Down Menu

4.3.8 Software Revision

The *Help...About* feature can be used to check the current software revision, as [Figure 4-5](#) illustrates. This document is based on revision 1.0.35.

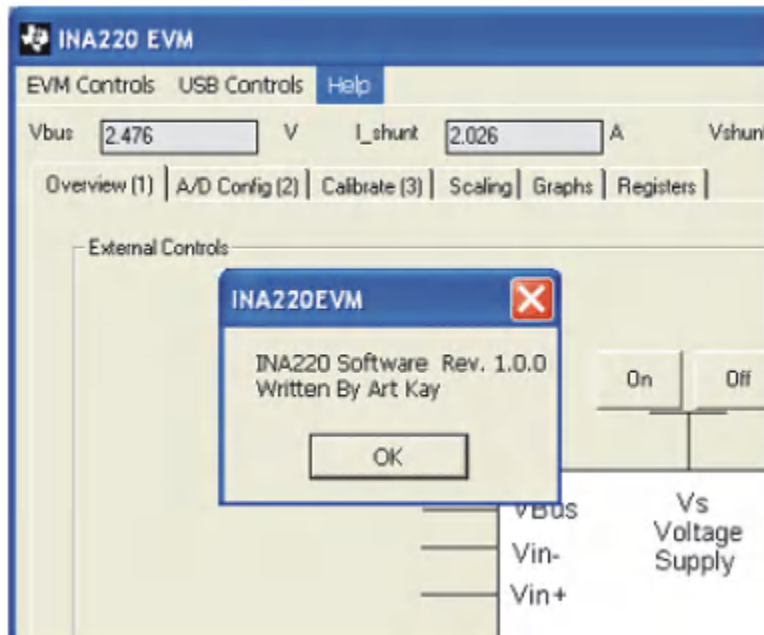

Figure 4-5. Current Software Revision

5 Bill of Materials

Table 5-1 shows the parts list for the INA220_Test_Board.

Table 5-1. INA220_Test_Board Parts List

NO.	QUANTITY	VALUE	REF DES	DESCRIPTION	VENDOR	PART NUMBER
1	1	4.02k	R5	Resistor, 4.02k, 603	ROHM	MCR03EZPFX4021
2	2	10k	R3, R4	Resistor, 10k, 603	Yageo Corporation	RC0603FR-0710KL
3	2	0Ω	R1, R2	RES 0.0 OHM 1/8W 5% 0805 SMD	Panasonic - ECG	ERJ-6GEY0R00V
4	1	10μF	C3	Capacitor, Tantalum, 10uF, 16V, 6032	Kemet	T491C106M016AT
5	1	0.1μF	C2	CAP .10UF 25V CERAMIC Y5V 0603	Kemet	C0603C104M3VACTU
6	0	Optional/Not Installed	C1	0603-1206 Capacitor	—	—
7	1	LED	D1	Diode, LED, Ultra Bright Diff, 603	Panasonic	LNJ208R8ARA
8	1	DSUB25M	J1	CONN D-SUB PLUG R/A 25POS 30GOLD (With Threaded Inserts and Board locks)	AMP/Tyco Electronics	5747842-4
9	3	N/A	N/A	SHUNT LP W/HANDLE 2 POS 30AU	AMP/Tyco Electronics	881545-2
10	5	JUMP3 cut to size	JMP1-JMP5	CONN HEADER 32POS .100" SGL GOLD (4 per Strip)	Samtec	TSW-132-07-G-S
11	4	Standoff	None	Standoffs, Hex , 4-40 Threaded, 0.500" length, 0.250" OD, Aluminum Iridite Finish	Keystone	2203
12	4	Screw	None	SCREW MACHINE PHIL 4-40X1/4 SS	Building Fasteners	PMSSS 440 0025 PH
13	11	Test point	N/A	5018 SMD Test Point	Keystone	5018
14	3	2-pin connector	T1, T2, T3	2-Position Terminal Strip, Cage Clamp, 45°, 15A, Dove-tailed	On-Shore Technology Inc	ED300/2
15	1	3-pin connector	T4	3-Position Terminal Strip, Cage Clamp, 45°, 15A, Dove-tailed	On-Shore Technology Inc	ED300/3

6 Revision History

NOTE: Page numbers for previous revisions may differ from page numbers in the current version.

Changes from Revision B (May 2016) to Revision C (March 2023) Page

- Changed user guide title for INA220EVM (Rev C) hardware support..... 1
-

Changes from Revision A (February 2010) to Revision B (May 2016) Page

- Changed [Figure 1-1](#)2
 - Changed list item from: "+6V power supply" to: "Barrel plug cable assembly..." in [Section 1.1](#)2
 - Added new paragraph and NOTE to [Section 2.3](#) 8
 - Added "(on USB DIG board)" to J5 in [Table 3-2](#)12
 - Addeddec "(on USB DIG board)" to J5 in [Table 3-3](#)12
-

Changes from Revision * (July, 2009) to Revision A (February 2010) Page

- Revised [Table 3-2](#)12
 - Added [Table 3-3](#) and [Table 3-4](#) 12
 - Added [Section 3.7](#) 15
 - Added [Section 3.8](#) 15
-

STANDARD TERMS FOR EVALUATION MODULES

1. *Delivery:* TI delivers TI evaluation boards, kits, or modules, including any accompanying demonstration software, components, and/or documentation which may be provided together or separately (collectively, an "EVM" or "EVMs") to the User ("User") in accordance with the terms set forth herein. User's acceptance of the EVM is expressly subject to the following terms.
 - 1.1 EVMs are intended solely for product or software developers for use in a research and development setting to facilitate feasibility evaluation, experimentation, or scientific analysis of TI semiconductor products. EVMs have no direct function and are not finished products. EVMs shall not be directly or indirectly assembled as a part or subassembly in any finished product. For clarification, any software or software tools provided with the EVM ("Software") shall not be subject to the terms and conditions set forth herein but rather shall be subject to the applicable terms that accompany such Software
 - 1.2 EVMs are not intended for consumer or household use. EVMs may not be sold, sublicensed, leased, rented, loaned, assigned, or otherwise distributed for commercial purposes by Users, in whole or in part, or used in any finished product or production system.
2. *Limited Warranty and Related Remedies/Disclaimers:*
 - 2.1 These terms do not apply to Software. The warranty, if any, for Software is covered in the applicable Software License Agreement.
 - 2.2 TI warrants that the TI EVM will conform to TI's published specifications for ninety (90) days after the date TI delivers such EVM to User. Notwithstanding the foregoing, TI shall not be liable for a nonconforming EVM if (a) the nonconformity was caused by neglect, misuse or mistreatment by an entity other than TI, including improper installation or testing, or for any EVMs that have been altered or modified in any way by an entity other than TI, (b) the nonconformity resulted from User's design, specifications or instructions for such EVMs or improper system design, or (c) User has not paid on time. Testing and other quality control techniques are used to the extent TI deems necessary. TI does not test all parameters of each EVM. User's claims against TI under this Section 2 are void if User fails to notify TI of any apparent defects in the EVMs within ten (10) business days after delivery, or of any hidden defects with ten (10) business days after the defect has been detected.
 - 2.3 TI's sole liability shall be at its option to repair or replace EVMs that fail to conform to the warranty set forth above, or credit User's account for such EVM. TI's liability under this warranty shall be limited to EVMs that are returned during the warranty period to the address designated by TI and that are determined by TI not to conform to such warranty. If TI elects to repair or replace such EVM, TI shall have a reasonable time to repair such EVM or provide replacements. Repaired EVMs shall be warranted for the remainder of the original warranty period. Replaced EVMs shall be warranted for a new full ninety (90) day warranty period.

WARNING

Evaluation Kits are intended solely for use by technically qualified, professional electronics experts who are familiar with the dangers and application risks associated with handling electrical mechanical components, systems, and subsystems.

User shall operate the Evaluation Kit within TI's recommended guidelines and any applicable legal or environmental requirements as well as reasonable and customary safeguards. Failure to set up and/or operate the Evaluation Kit within TI's recommended guidelines may result in personal injury or death or property damage. Proper set up entails following TI's instructions for electrical ratings of interface circuits such as input, output and electrical loads.

NOTE:

EXPOSURE TO ELECTROSTATIC DISCHARGE (ESD) MAY CAUSE DEGRADATION OR FAILURE OF THE EVALUATION KIT; TI RECOMMENDS STORAGE OF THE EVALUATION KIT IN A PROTECTIVE ESD BAG.

3 Regulatory Notices:

3.1 United States

3.1.1 Notice applicable to EVMs not FCC-Approved:

FCC NOTICE: This kit is designed to allow product developers to evaluate electronic components, circuitry, or software associated with the kit to determine whether to incorporate such items in a finished product and software developers to write software applications for use with the end product. This kit is not a finished product and when assembled may not be resold or otherwise marketed unless all required FCC equipment authorizations are first obtained. Operation is subject to the condition that this product not cause harmful interference to licensed radio stations and that this product accept harmful interference. Unless the assembled kit is designed to operate under part 15, part 18 or part 95 of this chapter, the operator of the kit must operate under the authority of an FCC license holder or must secure an experimental authorization under part 5 of this chapter.

3.1.2 For EVMs annotated as FCC – FEDERAL COMMUNICATIONS COMMISSION Part 15 Compliant:

CAUTION

This device complies with part 15 of the FCC Rules. Operation is subject to the following two conditions: (1) This device may not cause harmful interference, and (2) this device must accept any interference received, including interference that may cause undesired operation.

Changes or modifications not expressly approved by the party responsible for compliance could void the user's authority to operate the equipment.

FCC Interference Statement for Class A EVM devices

NOTE: This equipment has been tested and found to comply with the limits for a Class A digital device, pursuant to part 15 of the FCC Rules. These limits are designed to provide reasonable protection against harmful interference when the equipment is operated in a commercial environment. This equipment generates, uses, and can radiate radio frequency energy and, if not installed and used in accordance with the instruction manual, may cause harmful interference to radio communications. Operation of this equipment in a residential area is likely to cause harmful interference in which case the user will be required to correct the interference at his own expense.

FCC Interference Statement for Class B EVM devices

NOTE: This equipment has been tested and found to comply with the limits for a Class B digital device, pursuant to part 15 of the FCC Rules. These limits are designed to provide reasonable protection against harmful interference in a residential installation. This equipment generates, uses and can radiate radio frequency energy and, if not installed and used in accordance with the instructions, may cause harmful interference to radio communications. However, there is no guarantee that interference will not occur in a particular installation. If this equipment does cause harmful interference to radio or television reception, which can be determined by turning the equipment off and on, the user is encouraged to try to correct the interference by one or more of the following measures:

- Reorient or relocate the receiving antenna.
- Increase the separation between the equipment and receiver.
- Connect the equipment into an outlet on a circuit different from that to which the receiver is connected.
- Consult the dealer or an experienced radio/TV technician for help.

3.2 Canada

3.2.1 For EVMs issued with an Industry Canada Certificate of Conformance to RSS-210 or RSS-247

Concerning EVMs Including Radio Transmitters:

This device complies with Industry Canada license-exempt RSSs. Operation is subject to the following two conditions:

(1) this device may not cause interference, and (2) this device must accept any interference, including interference that may cause undesired operation of the device.

Concernant les EVMs avec appareils radio:

Le présent appareil est conforme aux CNR d'Industrie Canada applicables aux appareils radio exempts de licence. L'exploitation est autorisée aux deux conditions suivantes: (1) l'appareil ne doit pas produire de brouillage, et (2) l'utilisateur de l'appareil doit accepter tout brouillage radioélectrique subi, même si le brouillage est susceptible d'en compromettre le fonctionnement.

Concerning EVMs Including Detachable Antennas:

Under Industry Canada regulations, this radio transmitter may only operate using an antenna of a type and maximum (or lesser) gain approved for the transmitter by Industry Canada. To reduce potential radio interference to other users, the antenna type and its gain should be so chosen that the equivalent isotropically radiated power (e.i.r.p.) is not more than that necessary for successful communication. This radio transmitter has been approved by Industry Canada to operate with the antenna types listed in the user guide with the maximum permissible gain and required antenna impedance for each antenna type indicated. Antenna types not included in this list, having a gain greater than the maximum gain indicated for that type, are strictly prohibited for use with this device.

Concernant les EVMs avec antennes détachables

Conformément à la réglementation d'Industrie Canada, le présent émetteur radio peut fonctionner avec une antenne d'un type et d'un gain maximal (ou inférieur) approuvé pour l'émetteur par Industrie Canada. Dans le but de réduire les risques de brouillage radioélectrique à l'intention des autres utilisateurs, il faut choisir le type d'antenne et son gain de sorte que la puissance isotrope rayonnée équivalente (p.i.r.e.) ne dépasse pas l'intensité nécessaire à l'établissement d'une communication satisfaisante. Le présent émetteur radio a été approuvé par Industrie Canada pour fonctionner avec les types d'antenne énumérés dans le manuel d'usage et ayant un gain admissible maximal et l'impédance requise pour chaque type d'antenne. Les types d'antenne non inclus dans cette liste, ou dont le gain est supérieur au gain maximal indiqué, sont strictement interdits pour l'exploitation de l'émetteur.

3.3 Japan

3.3.1 *Notice for EVMs delivered in Japan:* Please see http://www.tij.co.jp/lstds/ti_ja/general/eStore/notice_01.page 日本国内に輸入される評価用キット、ボードについては、次のところをご覧ください。

<https://www.ti.com/ja-jp/legal/notice-for-evaluation-kits-delivered-in-japan.html>

3.3.2 *Notice for Users of EVMs Considered "Radio Frequency Products" in Japan:* EVMs entering Japan may not be certified by TI as conforming to Technical Regulations of Radio Law of Japan.

If User uses EVMs in Japan, not certified to Technical Regulations of Radio Law of Japan, User is required to follow the instructions set forth by Radio Law of Japan, which includes, but is not limited to, the instructions below with respect to EVMs (which for the avoidance of doubt are stated strictly for convenience and should be verified by User):

1. Use EVMs in a shielded room or any other test facility as defined in the notification #173 issued by Ministry of Internal Affairs and Communications on March 28, 2006, based on Sub-section 1.1 of Article 6 of the Ministry's Rule for Enforcement of Radio Law of Japan,
2. Use EVMs only after User obtains the license of Test Radio Station as provided in Radio Law of Japan with respect to EVMs, or
3. Use of EVMs only after User obtains the Technical Regulations Conformity Certification as provided in Radio Law of Japan with respect to EVMs. Also, do not transfer EVMs, unless User gives the same notice above to the transferee. Please note that if User does not follow the instructions above, User will be subject to penalties of Radio Law of Japan.

【無線電波を送信する製品の開発キットをお使いになる際の注意事項】 開発キットの中には技術基準適合証明を受けていないものがあります。技術適合証明を受けていないものご使用に際しては、電波法遵守のため、以下のいずれかの措置を取っていただく必要がありますのでご注意ください。

1. 電波法施行規則第6条第1項第1号に基づく平成18年3月28日総務省告示第173号で定められた電波暗室等の試験設備でご使用いただく。
2. 実験局の免許を取得後ご使用いただく。
3. 技術基準適合証明を取得後ご使用いただく。

なお、本製品は、上記の「ご使用にあたっての注意」を譲渡先、移転先に通知しない限り、譲渡、移転できないものとします。

上記を遵守頂けない場合は、電波法の罰則が適用される可能性があることをご留意ください。日本テキサス・イ

ンスツルメンツ株式会社

東京都新宿区西新宿 6 丁目 2 4 番 1 号

西新宿三井ビル

3.3.3 *Notice for EVMs for Power Line Communication:* Please see http://www.tij.co.jp/lstds/ti_ja/general/eStore/notice_02.page

電力線搬送波通信についての開発キットをお使いになる際の注意事項については、次のところをご覧ください。 <https://www.ti.com/ja-jp/legal/notice-for-evaluation-kits-for-power-line-communication.html>

3.4 European Union

3.4.1 *For EVMs subject to EU Directive 2014/30/EU (Electromagnetic Compatibility Directive):*

This is a class A product intended for use in environments other than domestic environments that are connected to a low-voltage power-supply network that supplies buildings used for domestic purposes. In a domestic environment this product may cause radio interference in which case the user may be required to take adequate measures.

-
- 4 *EVM Use Restrictions and Warnings:*
 - 4.1 EVMS ARE NOT FOR USE IN FUNCTIONAL SAFETY AND/OR SAFETY CRITICAL EVALUATIONS, INCLUDING BUT NOT LIMITED TO EVALUATIONS OF LIFE SUPPORT APPLICATIONS.
 - 4.2 User must read and apply the user guide and other available documentation provided by TI regarding the EVM prior to handling or using the EVM, including without limitation any warning or restriction notices. The notices contain important safety information related to, for example, temperatures and voltages.
 - 4.3 *Safety-Related Warnings and Restrictions:*
 - 4.3.1 User shall operate the EVM within TI's recommended specifications and environmental considerations stated in the user guide, other available documentation provided by TI, and any other applicable requirements and employ reasonable and customary safeguards. Exceeding the specified performance ratings and specifications (including but not limited to input and output voltage, current, power, and environmental ranges) for the EVM may cause personal injury or death, or property damage. If there are questions concerning performance ratings and specifications, User should contact a TI field representative prior to connecting interface electronics including input power and intended loads. Any loads applied outside of the specified output range may also result in unintended and/or inaccurate operation and/or possible permanent damage to the EVM and/or interface electronics. Please consult the EVM user guide prior to connecting any load to the EVM output. If there is uncertainty as to the load specification, please contact a TI field representative. During normal operation, even with the inputs and outputs kept within the specified allowable ranges, some circuit components may have elevated case temperatures. These components include but are not limited to linear regulators, switching transistors, pass transistors, current sense resistors, and heat sinks, which can be identified using the information in the associated documentation. When working with the EVM, please be aware that the EVM may become very warm.
 - 4.3.2 EVMs are intended solely for use by technically qualified, professional electronics experts who are familiar with the dangers and application risks associated with handling electrical mechanical components, systems, and subsystems. User assumes all responsibility and liability for proper and safe handling and use of the EVM by User or its employees, affiliates, contractors or designees. User assumes all responsibility and liability to ensure that any interfaces (electronic and/or mechanical) between the EVM and any human body are designed with suitable isolation and means to safely limit accessible leakage currents to minimize the risk of electrical shock hazard. User assumes all responsibility and liability for any improper or unsafe handling or use of the EVM by User or its employees, affiliates, contractors or designees.
 - 4.4 User assumes all responsibility and liability to determine whether the EVM is subject to any applicable international, federal, state, or local laws and regulations related to User's handling and use of the EVM and, if applicable, User assumes all responsibility and liability for compliance in all respects with such laws and regulations. User assumes all responsibility and liability for proper disposal and recycling of the EVM consistent with all applicable international, federal, state, and local requirements.
 5. *Accuracy of Information:* To the extent TI provides information on the availability and function of EVMs, TI attempts to be as accurate as possible. However, TI does not warrant the accuracy of EVM descriptions, EVM availability or other information on its websites as accurate, complete, reliable, current, or error-free.
 6. *Disclaimers:*
 - 6.1 EXCEPT AS SET FORTH ABOVE, EVMS AND ANY MATERIALS PROVIDED WITH THE EVM (INCLUDING, BUT NOT LIMITED TO, REFERENCE DESIGNS AND THE DESIGN OF THE EVM ITSELF) ARE PROVIDED "AS IS" AND "WITH ALL FAULTS." TI DISCLAIMS ALL OTHER WARRANTIES, EXPRESS OR IMPLIED, REGARDING SUCH ITEMS, INCLUDING BUT NOT LIMITED TO ANY EPIDEMIC FAILURE WARRANTY OR IMPLIED WARRANTIES OF MERCHANTABILITY OR FITNESS FOR A PARTICULAR PURPOSE OR NON-INFRINGEMENT OF ANY THIRD PARTY PATENTS, COPYRIGHTS, TRADE SECRETS OR OTHER INTELLECTUAL PROPERTY RIGHTS.
 - 6.2 EXCEPT FOR THE LIMITED RIGHT TO USE THE EVM SET FORTH HEREIN, NOTHING IN THESE TERMS SHALL BE CONSTRUED AS GRANTING OR CONFERRING ANY RIGHTS BY LICENSE, PATENT, OR ANY OTHER INDUSTRIAL OR INTELLECTUAL PROPERTY RIGHT OF TI, ITS SUPPLIERS/LICENSORS OR ANY OTHER THIRD PARTY, TO USE THE EVM IN ANY FINISHED END-USER OR READY-TO-USE FINAL PRODUCT, OR FOR ANY INVENTION, DISCOVERY OR IMPROVEMENT, REGARDLESS OF WHEN MADE, CONCEIVED OR ACQUIRED.
 7. *USER'S INDEMNITY OBLIGATIONS AND REPRESENTATIONS.* USER WILL DEFEND, INDEMNIFY AND HOLD TI, ITS LICENSORS AND THEIR REPRESENTATIVES HARMLESS FROM AND AGAINST ANY AND ALL CLAIMS, DAMAGES, LOSSES, EXPENSES, COSTS AND LIABILITIES (COLLECTIVELY, "CLAIMS") ARISING OUT OF OR IN CONNECTION WITH ANY HANDLING OR USE OF THE EVM THAT IS NOT IN ACCORDANCE WITH THESE TERMS. THIS OBLIGATION SHALL APPLY WHETHER CLAIMS ARISE UNDER STATUTE, REGULATION, OR THE LAW OF TORT, CONTRACT OR ANY OTHER LEGAL THEORY, AND EVEN IF THE EVM FAILS TO PERFORM AS DESCRIBED OR EXPECTED.
-

8. *Limitations on Damages and Liability:*

8.1 *General Limitations.* IN NO EVENT SHALL TI BE LIABLE FOR ANY SPECIAL, COLLATERAL, INDIRECT, PUNITIVE, INCIDENTAL, CONSEQUENTIAL, OR EXEMPLARY DAMAGES IN CONNECTION WITH OR ARISING OUT OF THESE TERMS OR THE USE OF THE EVMS , REGARDLESS OF WHETHER TI HAS BEEN ADVISED OF THE POSSIBILITY OF SUCH DAMAGES. EXCLUDED DAMAGES INCLUDE, BUT ARE NOT LIMITED TO, COST OF REMOVAL OR REINSTALLATION, ANCILLARY COSTS TO THE PROCUREMENT OF SUBSTITUTE GOODS OR SERVICES, RETESTING, OUTSIDE COMPUTER TIME, LABOR COSTS, LOSS OF GOODWILL, LOSS OF PROFITS, LOSS OF SAVINGS, LOSS OF USE, LOSS OF DATA, OR BUSINESS INTERRUPTION. NO CLAIM, SUIT OR ACTION SHALL BE BROUGHT AGAINST TI MORE THAN TWELVE (12) MONTHS AFTER THE EVENT THAT GAVE RISE TO THE CAUSE OF ACTION HAS OCCURRED.

8.2 *Specific Limitations.* IN NO EVENT SHALL TI'S AGGREGATE LIABILITY FROM ANY USE OF AN EVM PROVIDED HEREUNDER, INCLUDING FROM ANY WARRANTY, INDEMNITY OR OTHER OBLIGATION ARISING OUT OF OR IN CONNECTION WITH THESE TERMS, , EXCEED THE TOTAL AMOUNT PAID TO TI BY USER FOR THE PARTICULAR EVM(S) AT ISSUE DURING THE PRIOR TWELVE (12) MONTHS WITH RESPECT TO WHICH LOSSES OR DAMAGES ARE CLAIMED. THE EXISTENCE OF MORE THAN ONE CLAIM SHALL NOT ENLARGE OR EXTEND THIS LIMIT.

9. *Return Policy.* Except as otherwise provided, TI does not offer any refunds, returns, or exchanges. Furthermore, no return of EVM(s) will be accepted if the package has been opened and no return of the EVM(s) will be accepted if they are damaged or otherwise not in a resalable condition. If User feels it has been incorrectly charged for the EVM(s) it ordered or that delivery violates the applicable order, User should contact TI. All refunds will be made in full within thirty (30) working days from the return of the components(s), excluding any postage or packaging costs.

10. *Governing Law:* These terms and conditions shall be governed by and interpreted in accordance with the laws of the State of Texas, without reference to conflict-of-laws principles. User agrees that non-exclusive jurisdiction for any dispute arising out of or relating to these terms and conditions lies within courts located in the State of Texas and consents to venue in Dallas County, Texas. Notwithstanding the foregoing, any judgment may be enforced in any United States or foreign court, and TI may seek injunctive relief in any United States or foreign court.

Mailing Address: Texas Instruments, Post Office Box 655303, Dallas, Texas 75265
Copyright © 2023, Texas Instruments Incorporated

IMPORTANT NOTICE AND DISCLAIMER

TI PROVIDES TECHNICAL AND RELIABILITY DATA (INCLUDING DATA SHEETS), DESIGN RESOURCES (INCLUDING REFERENCE DESIGNS), APPLICATION OR OTHER DESIGN ADVICE, WEB TOOLS, SAFETY INFORMATION, AND OTHER RESOURCES "AS IS" AND WITH ALL FAULTS, AND DISCLAIMS ALL WARRANTIES, EXPRESS AND IMPLIED, INCLUDING WITHOUT LIMITATION ANY IMPLIED WARRANTIES OF MERCHANTABILITY, FITNESS FOR A PARTICULAR PURPOSE OR NON-INFRINGEMENT OF THIRD PARTY INTELLECTUAL PROPERTY RIGHTS.

These resources are intended for skilled developers designing with TI products. You are solely responsible for (1) selecting the appropriate TI products for your application, (2) designing, validating and testing your application, and (3) ensuring your application meets applicable standards, and any other safety, security, regulatory or other requirements.

These resources are subject to change without notice. TI grants you permission to use these resources only for development of an application that uses the TI products described in the resource. Other reproduction and display of these resources is prohibited. No license is granted to any other TI intellectual property right or to any third party intellectual property right. TI disclaims responsibility for, and you will fully indemnify TI and its representatives against, any claims, damages, costs, losses, and liabilities arising out of your use of these resources.

TI's products are provided subject to [TI's Terms of Sale](#) or other applicable terms available either on [ti.com](https://www.ti.com) or provided in conjunction with such TI products. TI's provision of these resources does not expand or otherwise alter TI's applicable warranties or warranty disclaimers for TI products.

TI objects to and rejects any additional or different terms you may have proposed.

Mailing Address: Texas Instruments, Post Office Box 655303, Dallas, Texas 75265
Copyright © 2023, Texas Instruments Incorporated