

## USB72x6/USB7252 Silicon Errata and Data Sheet Clarification

This document describes known silicon errata for the following USB72x6/USB7252 devices:

- USB7206
- USB7216
- USB7252

The silicon errata discussed in this document are for silicon revisions as listed in [Table 1](#). The silicon revision can be determined by the device's top marking as indicated in [Figure 1](#). A summary of USB72x6/USB7252 silicon errata is provided in [Table 2](#).

**TABLE 1: AFFECTED SILICON REVISIONS**

Part Numbers	Silicon Revision
USB7206, USB7216, USB7252	B1, C1

**FIGURE 1: TOP MARKING SILICON REVISION INDICATION**

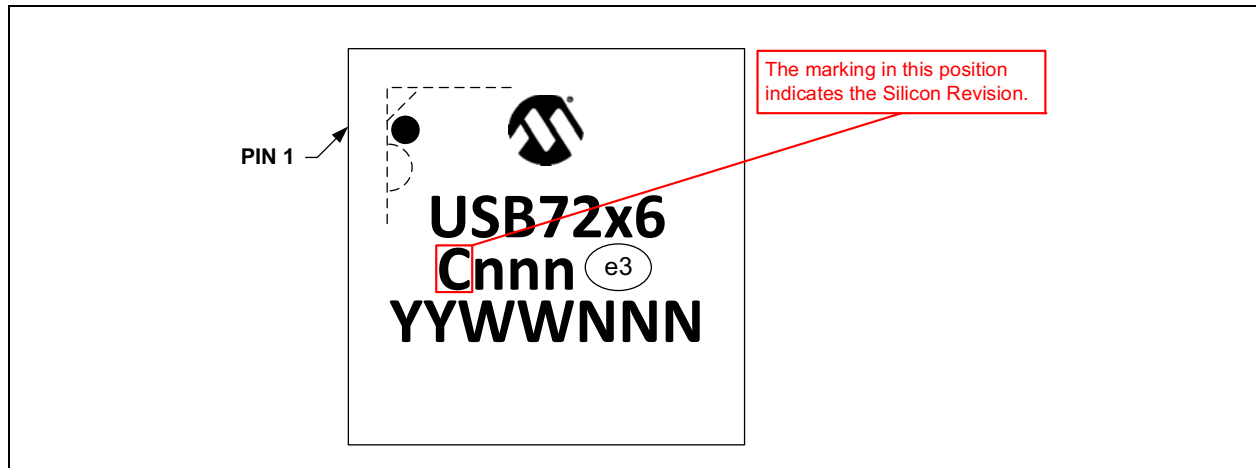

**Note:** [Figure 1](#) details the top markings of an example part and highlights the location of the silicon revision. Other top marking values may differ (lot codes, location of manufacture, and so on).

# USB72x6/USB7252

**TABLE 2: SILICON ISSUE SUMMARY**

Item Number	Silicon Issue Summary	Affected Silicon Revisions
1.	FlexConnect USB 3.0 operation requires special conditions	B1
2.	Type-C Bridging	B1
3.	Type-C VBUS discharge in Port Power On/Off test	B1, C1
4.	I <sup>2</sup> C Bridge sends an extra byte under certain conditions	B1
5.	PF29 cannot be initialized by configuration OTP	B1
6.	Clock Data Recovery Block Power-On Failures for Small Subset of Devices at USB3.x Gen 1 speeds	B1
7.	Incorrect default billboard device descriptor values	C1
8.	PID and Product String hub descriptors cannot be modified on USB7216C devices	C1

## Silicon Errata Issues

### Module 1: FlexConnect USB 3.0 operation requires special conditions

#### DESCRIPTION

FlexConnect: For USB 3.0 connections only, the following conditions exist:

- The Flexed port may not re-enumerate if disconnected and reconnected.
- After flexing and unflexing, the UFP may not re-enumerate.

These conditions are avoided if both of the following steps are taken:

1. Run the hub using SPI Flash memory.
2. Disable the host (PC) power management.

**Note:** USB 2.0 connections enumerate normally in all FlexConnect states.

#### END USER IMPLICATIONS

If FlexConnect operation is required for USB 3.0 connections, both of the following must be met:

- The hub must operate using SPI Flash memory.
- Host power management must be disabled.

#### Work Around

None.

#### PLAN

This erratum is fixed in revision C1 silicon.

### Module 2: Type-C Bridging

#### DESCRIPTION

The internal Type-C Bridge device is not implemented for USB7216 and USB7252 devices with only basic Type-C ports.

#### END USER IMPLICATIONS

There is no end user impact as long as USB 3 Hub Command Verifier (HUB3CV) Ver. 2.1.12.1 or later is used; with this version, a missing Type-C Bridge device will not result in a compliance test failure.

## Work Around

None.

## PLAN

This erratum is fixed in revision C1 silicon.

## Module 3: Type-C VBUS discharge in Port Power On/Off test

### DESCRIPTION

One requirement for USB-IF compliance certification of a system with an exposed Type-C port is the *Port Power On/Off* test. This test is part of the HUBCV suite of *Command Verification* tests for USB 2 devices. As part of this test, the hub must discharge VBUS, and then energize VBUS in response to CLEAR\_FEATURE and SET\_FEATURE commands from the test host.

Frequently, these ports will be implemented with electrolytic VBUS load capacitors, which retain a small residual charge that is released slowly compared to the timing of the discharge. In such cases, as energy is released from the capacitor the voltage can drift upward slightly after the discharge, which can cross the VBUS\_DET threshold for detecting VBUS high. In the sequence of the Port Power On/Off test, this can inhibit subsequent turning on of VBUS in response to commands from the test host and the test fails.

This issue does not impact normal operation of the port. Only the Port Power On/Off test is affected.

### END USER IMPLICATIONS

Type C ports that have a large electrolytic capacitor may require this workaround to pass the HUBCV Port Power On/Off test.

Applications that do not perform HUBCV testing are not affected.

## Work Around

In reference designs for USB7216 and USB7252 devices, an N-channel MOSFET with a  $V_{GS}$  less than 1.0V is connected between VBUS and VBUS\_MON, with gate control from the DISCHARGE signal. This additional component creates an additional current path as the discharge is monitored by VBUS\_MON, which biases VBUS\_MON higher. This results in discharge to a lower voltage than what is otherwise achieved, and compensates for any residual energy that the capacitor releases after the discharge. At times other than the discharge, the MOSFET is turned off and does not influence VBUS.

No components of the reference design need to be removed; only the MOSFET is added.

**FIGURE 2: TYPE-C DISCHARGE WORKAROUND FOR MODULE 3**

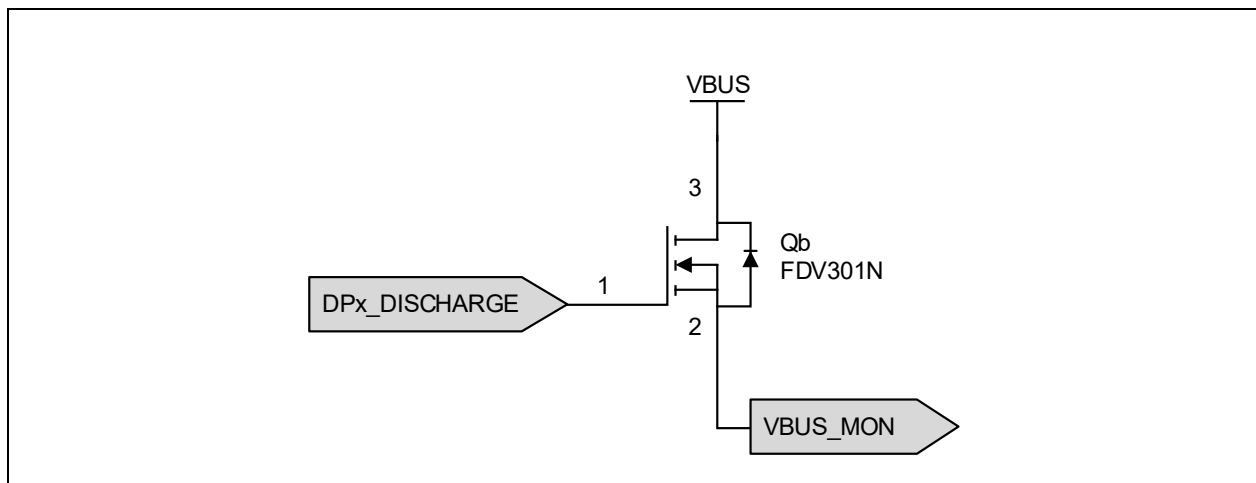

## PLAN

There is no plan to correct this erratum.

# USB72x6/USB7252

---

---

## Module 4: I<sup>2</sup>C Bridge sends an extra byte under certain conditions

### DESCRIPTION

USB7252 is an I<sup>2</sup>C master that is connected to an I<sup>2</sup>C slave. In the case where a single byte is to be read, the I<sup>2</sup>C Bridge responds by reading two bytes. The first of these bytes has an ACK bit, and the second byte has a NACK bit. Only the first byte contains correct data, and the value of the second byte is unpredictable. Only the valid byte is returned to the application or the I<sup>2</sup>C Read Buffer.

This phenomenon is also seen in cases where the number of bytes to be read is equal to a multiple of 128 plus 1 (for example, 129 bytes, 257 bytes, and so on).

<b>Note:</b> This module applies to all USB7206, USB7216, and USB7252 devices Revision B1.
--

### END USER IMPLICATIONS

I<sup>2</sup>C slaves may not expect the second byte. The I<sup>2</sup>C slave software may interpret the incorrect byte as valid, and may malfunction.

#### **Work Around**

The I<sup>2</sup>C master software should avoid reading a single byte. When only one byte is desired, the I<sup>2</sup>C master software should read two bytes and discard the second byte.

### PLAN

1. An OTP patch is available that corrects the error in the case of reading one byte. It does not correct the other cases (129 bytes, 257 bytes, and so on).
2. This erratum is fixed in revision C1 silicon.

## Module 5: PF29 cannot be initialized by configuration OTP

### DESCRIPTION

After reset, PF29 is initialized to these conditions:

- Output is enabled
- Input is enabled
- Output value is High (1)
- Pull-up is enabled
- Open-drain is enabled

These initial conditions cannot be altered by means of writing to the GPIO control registers from configuration OTP.

After initialization is complete (that is, in runtime), the value of the GPIO registers can be altered in the normal manner: through USB host control or through SMBus control.

### END USER IMPLICATIONS

If the initial state of PF29 is unacceptable, then a different GPIO pin must be used.

If the initial state of PF29 is not a concern, then PF29 can be used.

#### **Work Around**

None.

### PLAN

This erratum is fixed in revision C1 silicon.

## Module 6: Clock Data Recovery Block Power-On Failures for Small Subset of Devices at USB3.x Gen 1 speeds

### DESCRIPTION

On a small subset of devices, the clock data recovery block within one or more USB3.2 PHYs may not properly power on when operating at USB3.x Gen 1 (5GHz) speeds.

This failure does not occur when operating at USB3.x Gen 2 (10GHz) or USB2.0-only speeds.

### END USER IMPLICATIONS

Devices affected with this errata may fail to connect at USB3.x Gen 1 speeds on the affected port, which may be the upstream port or any of the downstream ports.

#### **Work Around**

This workaround may be applied universally to all commercial-grade devices to guard against this failure. The following register settings elevate the internal voltage supply to the clock data recovery block. The registers may be modified via 1 of 3 options:

**OTP Memory:** Programmed permanently at the time of production or in the field through USB or SMBus.

**SMBus interface:** Set after every power-on/reset.

**External SPI Memory:** "Pseudo-OTP" memory space when executing firmware and configuration from external SPI memory.

#### **USB3.2 PHY0 (UFP) Register Settings:**

0xBF80\_6082 = 0x02

0xBF80\_6083 = 0x5F

0xBF80\_6086 = 0x04

#### **USB3.2 PHY1 Register Settings:**

0xBF80\_6482 = 0x02

0xBF80\_6483 = 0x5F

0xBF80\_6486 = 0x04

#### **USB3.2 PHY2 Register Settings:**

0xBF80\_6882 = 0x02

0xBF80\_6883 = 0x5F

0xBF80\_6886 = 0x04

#### **USB3.2 PHY3 Register Settings:**

0xBF80\_6C82 = 0x02

0xBF80\_6C83 = 0x5F

0xBF80\_6C86 = 0x04

#### **USB3.2 PHY4 Register Settings:**

0xBF80\_7082 = 0x02

0xBF80\_7083 = 0x5F

0xBF80\_7086 = 0x04

# USB72x6/USB7252

---

## USB3.2 PHY5 Register Settings:

0xBF80\_7482 = 0x02

0xBF80\_7483 = 0x5F

0xBF80\_7486 = 0x04

**Global Settings (must be applied after the USB Attach Command with SMBus Active [0xAA 0x56] is issued if configuring via SMBus):**

0xBF80\_6019 = 0x1F

## PLAN

**Commercial-grade B1 Revision Silicon:** The register-based workaround will be included in all B1 silicon devices moving forward. The fix can be verified by checking the bcdDevice descriptor of the hub:

- USB7206 devices with bcdDevice = 0x0612 or higher
- USB7216 devices with bcdDevice = 0x0613 or higher
- USB7252 devices with bcdDevice = 0x0614 or higher

**Industrial-grade B1 Revision Silicon:** There is no plan to address this erratum for Industrial-grade B1 devices. Use Revision C1 or newer devices.

**All C1 or Newer Revision Silicon:** This erratum is fixed in revision C1 silicon (consumer or industrial-grade).

## Module 7: Incorrect default billboard device descriptor values

### DESCRIPTION

The default billboard device descriptors of USB7206C and USB7216C devices are not correct by default.

### END USER IMPLICATIONS

Billboard device enumeration will not generate a pop-up billboard device message to the user as expected.

#### **Work Around**

The following register settings can correct this issue via any of the 3 configuration mechanisms:

**OTP Memory:** Programmed permanently at the time of production or in the field through USB or SMBus.

**SMBus interface:** Set after every power-on/reset.

**External SPI Memory:** “Pseudo-OTP” memory space when executing firmware and configuration from external SPI memory.

#### **Corrected Billboard Device Descriptor Settings:**

0xBF80\_4604 = 0x08 0x10 0x0F 0x01 0x02 0x00 0x00 0x00 0x08 0x10 0x0F 0x02 0xC5 0x00 0xC0 0x00

0xBF80\_45C8 = 0x03

## PLAN

This erratum will not be corrected in a future revision.

## Module 8: PID and Product String hub descriptors cannot be modified on USB7216C devices

### DESCRIPTION

On all USB7216C devices, the LSB of the USB2 and USB3 hub PID cannot be changed from the default value of 16h. The hub firmware is overwriting this value at boot and any attempt to modify it via OTP programming will be unsuccessful.

Similarly, USB3 hub Product String descriptors cannot be properly changed. Any attempt to modify the product string via OTP programming will be unsuccessful as the value of '16' within the string descriptor will always be overwritten by the hub firmware at boot.

### END USER IMPLICATIONS

The USB Hub Product ID (PID) and Product Strings of both the USB2 hub and USB3 hub cannot be modified properly from the default settings.

#### **Work Around**

This issue can be addressed by applying an additional OTP-based firmware patch which modifies the register location by which the PID and string descriptors are stored. Contact Microchip support for instructions and assistance.

### PLAN

This erratum will not be corrected in a future revision.

# USB72x6/USB7252

## APPENDIX A: DOCUMENT REVISION HISTORY

Revision Level & Date	Section/Figure/Entry	Correction
DS80000847E (02-10-22)	All	Updated document for C1 silicon.
	Table 1	Added C1 silicon revision to list.
	Figure 1	Updated figure to indicate where the silicon revision can be determined in the package top marking.
	Table 2	Added affected silicon revisions column.
	Modules 1., 2., 4., 5., 6.	Updated Plan section to indicate the erratum is fixed in revision C1 silicon.
	Module 7.	Added new module.
	Module 8.	Added new module.
DS80000847D (03-12-21)	Clock Data Recovery Block Power-On Failures for Small Subset of Devices at USB3.x Gen 1 speeds	Added this section.
DS80000847C (08-14-20)	PF29 cannot be initialized by configuration OTP	Added this section.
DS80000847B (05-14-20)	Table 1	Added part number USB7252 in the list of affected silicon revisions.
	Type-C Bridging	Updated to show impact to USB7252.
	Type-C VBUS discharge in Port Power On/Off test	Added this section describing Type-C VBUS discharge in Port Power On/Off test.
	I <sup>2</sup> C Bridge sends an extra byte under certain conditions	Added this section describing the scenario where the I <sup>2</sup> C Bridge sends two bytes of data
DS80000847A (09-19-19)	Initial release	



## THE MICROCHIP WEB SITE

Microchip provides online support via our WWW site at [www.microchip.com](http://www.microchip.com). This web site is used as a means to make files and information easily available to customers. Accessible by using your favorite Internet browser, the web site contains the following information:

- **Product Support** – Data sheets and errata, application notes and sample programs, design resources, user's guides and hardware support documents, latest software releases and archived software
- **General Technical Support** – Frequently Asked Questions (FAQ), technical support requests, online discussion groups, Microchip consultant program member listing
- **Business of Microchip** – Product selector and ordering guides, latest Microchip press releases, listing of seminars and events, listings of Microchip sales offices, distributors and factory representatives

## CUSTOMER CHANGE NOTIFICATION SERVICE

Microchip's customer notification service helps keep customers current on Microchip products. Subscribers will receive e-mail notification whenever there are changes, updates, revisions or errata related to a specified product family or development tool of interest.

To register, access the Microchip web site at [www.microchip.com](http://www.microchip.com). Under "Support", click on "Customer Change Notification" and follow the registration instructions.

## CUSTOMER SUPPORT

Users of Microchip products can receive assistance through several channels:

- Distributor or Representative
- Local Sales Office
- Field Application Engineer (FAE)
- Technical Support

Customers should contact their distributor, representative or field application engineer (FAE) for support. Local sales offices are also available to help customers. A listing of sales offices and locations is included in the back of this document.

**Technical support is available through the web site at: <http://microchip.com/support>**

# USB72x6/USB7252

---

## Note the following details of the code protection feature on Microchip products:

- Microchip products meet the specifications contained in their particular Microchip Data Sheet.
- Microchip believes that its family of products is secure when used in the intended manner, within operating specifications, and under normal conditions.
- Microchip values and aggressively protects its intellectual property rights. Attempts to breach the code protection features of Microchip product is strictly prohibited and may violate the Digital Millennium Copyright Act.
- Neither Microchip nor any other semiconductor manufacturer can guarantee the security of its code. Code protection does not mean that we are guaranteeing the product is “unbreakable”. Code protection is constantly evolving. Microchip is committed to continuously improving the code protection features of our products.

---

This publication and the information herein may be used only with Microchip products, including to design, test, and integrate Microchip products with your application. Use of this information in any other manner violates these terms. Information regarding device applications is provided only for your convenience and may be superseded by updates. It is your responsibility to ensure that your application meets with your specifications. Contact your local Microchip sales office for additional support or, obtain additional support at <https://www.microchip.com/en-us/support/design-help/client-support-services>.

THIS INFORMATION IS PROVIDED BY MICROCHIP "AS IS". MICROCHIP MAKES NO REPRESENTATIONS OR WARRANTIES OF ANY KIND WHETHER EXPRESS OR IMPLIED, WRITTEN OR ORAL, STATUTORY OR OTHERWISE, RELATED TO THE INFORMATION INCLUDING BUT NOT LIMITED TO ANY IMPLIED WARRANTIES OF NON-INFRINGEMENT, MERCHANTABILITY, AND FITNESS FOR A PARTICULAR PURPOSE, OR WARRANTIES RELATED TO ITS CONDITION, QUALITY, OR PERFORMANCE.

IN NO EVENT WILL MICROCHIP BE LIABLE FOR ANY INDIRECT, SPECIAL, PUNITIVE, INCIDENTAL, OR CONSEQUENTIAL LOSS, DAMAGE, COST, OR EXPENSE OF ANY KIND WHATSOEVER RELATED TO THE INFORMATION OR ITS USE, HOWEVER CAUSED, EVEN IF MICROCHIP HAS BEEN ADVISED OF THE POSSIBILITY OR THE DAMAGES ARE FORESEEABLE. TO THE FULLEST EXTENT ALLOWED BY LAW, MICROCHIP'S TOTAL LIABILITY ON ALL CLAIMS IN ANY WAY RELATED TO THE INFORMATION OR ITS USE WILL NOT EXCEED THE AMOUNT OF FEES, IF ANY, THAT YOU HAVE PAID DIRECTLY TO MICROCHIP FOR THE INFORMATION.

Use of Microchip devices in life support and/or safety applications is entirely at the buyer's risk, and the buyer agrees to defend, indemnify and hold harmless Microchip from any and all damages, claims, suits, or expenses resulting from such use. No licenses are conveyed, implicitly or otherwise, under any Microchip intellectual property rights unless otherwise stated.

## Trademarks

The Microchip name and logo, the Microchip logo, Adaptec, AnyRate, AVR, AVR logo, AVR Freaks, BesTime, BitCloud, CryptoMemory, CryptoRF, dsPIC, flexPWR, HELDO, IGLOO, JukeBlox, KeeLoq, Klear, LANCheck, LinkMD, maXStylus, maXTouch, MediaLB, megaAVR, Microsemi, Microsemi logo, MOST, MOST logo, MPLAB, OptoLyzer, PIC, picoPower, PICSTART, PIC32 logo, PolarFire, Prochip Designer, QTouch, SAM-BA, SenGenuity, SpyNIC, SST, SST Logo, SuperFlash, Symmetricom, SyncServer, Tachyon, TimeSource, tinyAVR, UNI/O, Vectron, and XMEGA are registered trademarks of Microchip Technology Incorporated in the U.S.A. and other countries.

AgileSwitch, APT, ClockWorks, The Embedded Control Solutions Company, EtherSynch, Flashtec, Hyper Speed Control, HyperLight Load, IntelliMOS, Libero, motorBench, mTouch, Powermite 3, Precision Edge, ProASIC, ProASIC Plus, ProASIC Plus logo, Quiet-Wire, SmartFusion, SyncWorld, Temux, TimeCesium, TimeHub, TimePictra, TimeProvider, TrueTime, WinPath, and ZL are registered trademarks of Microchip Technology Incorporated in the U.S.A.

Adjacent Key Suppression, AKS, Analog-for-the-Digital Age, Any Capacitor, AnyIn, AnyOut, Augmented Switching, BlueSky, BodyCom, CodeGuard, CryptoAuthentication, CryptoAutomotive, CryptoCompanion, CryptoController, dsPICDEM, dsPICDEM.net, Dynamic Average Matching, DAM, ECAN, Espresso T1S, EtherGREEN, GridTime, IdealBridge, In-Circuit Serial Programming, ICSP, INICnet, Intelligent Paralleling, Inter-Chip Connectivity, JitterBlocker, Knob-on-Display, maxCrypto, maxView, memBrain, Mindi, MiWi, MPASM, MPF, MPLAB Certified logo, MPLIB, MPLINK, MultiTRAK, NetDetach, NVM Express, NVMe, Omniscient Code Generation, PICDEM, PICDEM.net, PICkit, PICtail, PowerSmart, PureSilicon, QMatrix, REAL ICE, Ripple Blocker, RTAX, RTG4, SAM-ICE, Serial Quad I/O, simpleMAP, SimpliPHY, SmartBuffer, SmartHLS, SMART-I.S., storClad, SQL, SuperSwitcher, SuperSwitcher II, Switchtec, SynchroPHY, Total Endurance, TSHARC, USBCheck, VariSense, VectorBlox, VeriPHY, ViewSpan, WiperLock, XpressConnect, and ZENA are trademarks of Microchip Technology Incorporated in the U.S.A. and other countries.

SQTP is a service mark of Microchip Technology Incorporated in the U.S.A.

The Adaptec logo, Frequency on Demand, Silicon Storage Technology, Symmcom, and Trusted Time are registered trademarks of Microchip Technology Inc. in other countries.

GestIC is a registered trademark of Microchip Technology Germany II GmbH & Co. KG, a subsidiary of Microchip Technology Inc., in other countries.

All other trademarks mentioned herein are property of their respective companies.

© 2022, Microchip Technology Incorporated and its subsidiaries.

All Rights Reserved.

ISBN: 9781522497851

For information regarding Microchip's Quality Management Systems, please visit [www.microchip.com/quality](http://www.microchip.com/quality).



## Worldwide Sales and Service

### AMERICAS

**Corporate Office**  
2355 West Chandler Blvd.  
Chandler, AZ 85224-6199  
Tel: 480-792-7200  
Fax: 480-792-7277  
Technical Support:  
[http://www.microchip.com/  
support](http://www.microchip.com/support)  
Web Address:  
[www.microchip.com](http://www.microchip.com)

#### Atlanta

Duluth, GA  
Tel: 678-957-9614  
Fax: 678-957-1455

#### Austin, TX

Tel: 512-257-3370

#### Boston

Westborough, MA  
Tel: 774-760-0087  
Fax: 774-760-0088

#### Chicago

Itasca, IL  
Tel: 630-285-0071  
Fax: 630-285-0075

#### Dallas

Addison, TX  
Tel: 972-818-7423  
Fax: 972-818-2924

#### Detroit

Novi, MI  
Tel: 248-848-4000

#### Houston, TX

Tel: 281-894-5983

#### Indianapolis

Noblesville, IN  
Tel: 317-773-8323  
Fax: 317-773-5453  
Tel: 317-536-2380

#### Los Angeles

Mission Viejo, CA  
Tel: 949-462-9523  
Fax: 949-462-9608  
Tel: 951-273-7800

#### Raleigh, NC

Tel: 919-844-7510

#### New York, NY

Tel: 631-435-6000

#### San Jose, CA

Tel: 408-735-9110  
Tel: 408-436-4270

#### Canada - Toronto

Tel: 905-695-1980  
Fax: 905-695-2078

### ASIA/PACIFIC

**Australia - Sydney**  
Tel: 61-2-9868-6733

**China - Beijing**  
Tel: 86-10-8569-7000

**China - Chengdu**  
Tel: 86-28-8665-5511

**China - Chongqing**  
Tel: 86-23-8980-9588

**China - Dongguan**  
Tel: 86-769-8702-9880

**China - Guangzhou**  
Tel: 86-20-8755-8029

**China - Hangzhou**  
Tel: 86-571-8792-8115

**China - Hong Kong SAR**  
Tel: 852-2943-5100

**China - Nanjing**  
Tel: 86-25-8473-2460

**China - Qingdao**  
Tel: 86-532-8502-7355

**China - Shanghai**  
Tel: 86-21-3326-8000

**China - Shenyang**  
Tel: 86-24-2334-2829

**China - Shenzhen**  
Tel: 86-755-8864-2200

**China - Suzhou**  
Tel: 86-186-6233-1526

**China - Wuhan**  
Tel: 86-27-5980-5300

**China - Xian**  
Tel: 86-29-8833-7252

**China - Xiamen**  
Tel: 86-592-2388138

**China - Zhuhai**  
Tel: 86-756-3210040

### ASIA/PACIFIC

**India - Bangalore**  
Tel: 91-80-3090-4444

**India - New Delhi**  
Tel: 91-11-4160-8631

**India - Pune**  
Tel: 91-20-4121-0141

**Japan - Osaka**  
Tel: 81-6-6152-7160

**Japan - Tokyo**  
Tel: 81-3-6880-3770

**Korea - Daegu**  
Tel: 82-53-744-4301

**Korea - Seoul**  
Tel: 82-2-554-7200

**Malaysia - Kuala Lumpur**  
Tel: 60-3-7651-7906

**Malaysia - Penang**  
Tel: 60-4-227-8870

**Philippines - Manila**  
Tel: 63-2-634-9065

**Singapore**  
Tel: 65-6334-8870

**Taiwan - Hsin Chu**  
Tel: 886-3-577-8366

**Taiwan - Kaohsiung**  
Tel: 886-7-213-7830

**Taiwan - Taipei**  
Tel: 886-2-2508-8600

**Thailand - Bangkok**  
Tel: 66-2-694-1351

**Vietnam - Ho Chi Minh**  
Tel: 84-28-5448-2100

### EUROPE

**Austria - Wels**  
Tel: 43-7242-2244-39  
Fax: 43-7242-2244-393

**Denmark - Copenhagen**  
Tel: 45-4485-5910  
Fax: 45-4485-2829

**Finland - Espoo**  
Tel: 358-9-4520-820

**France - Paris**  
Tel: 33-1-69-53-63-20  
Fax: 33-1-69-30-90-79

**Germany - Garching**  
Tel: 49-8931-9700

**Germany - Haan**  
Tel: 49-2129-3766400

**Germany - Heilbronn**  
Tel: 49-7131-72400

**Germany - Karlsruhe**  
Tel: 49-721-625370

**Germany - Munich**  
Tel: 49-89-627-144-0  
Fax: 49-89-627-144-44

**Germany - Rosenheim**  
Tel: 49-8031-354-560

**Israel - Ra'anana**  
Tel: 972-9-744-7705

**Italy - Milan**  
Tel: 39-0331-742611  
Fax: 39-0331-466781

**Italy - Padova**  
Tel: 39-049-7625286

**Netherlands - Drunen**  
Tel: 31-416-690399  
Fax: 31-416-690340

**Norway - Trondheim**  
Tel: 47-7288-4388

**Poland - Warsaw**  
Tel: 48-22-3325737

**Romania - Bucharest**  
Tel: 40-21-407-87-50

**Spain - Madrid**  
Tel: 34-91-708-08-90  
Fax: 34-91-708-08-91

**Sweden - Gothenberg**  
Tel: 46-31-704-60-40

**Sweden - Stockholm**  
Tel: 46-8-5090-4654

**UK - Wokingham**  
Tel: 44-118-921-5800  
Fax: 44-118-921-5820