

FAA-PMA

D-7AC

REV.	DESCRIPTION	DATE	APPROVED
J	REDRAWN, NOTES 3 & 4, & REMOVE PAINT ADDED	95/01/13	R. S.
K	29281 ITEM 4 WAS 32257-001	95/12/28	RS
L	30701 QTY ITEM 9 WAS 5; ADDED ITEMS 14, 15 & 16	96/08/02	RS
M	35441 NOTE 5 ADDED	98/05/04	RS

CONSTRUCTION  
 NOMINAL VOLTAGE  
 CONTACT RATING, RES AND IND  
 A1-A2, A3-A4  
 INTERRUPTION CAPABILITY  
 COIL RATING  
 PICKUP  
 DROPOUT  
 RATED DUTY  
 VIBRATION  
 AMBIENT TEMP.  
 MAX. WEIGHT

GASKET SEALED & VENTED  
 28VDC  
 50 AMP AT 28 VDC  
 500 AMP  
 28VDC  
 18V. MAX. HOT  
 7 V. MAX. HOT  
 CONTINUOUS  
 15 G'S TO 1000 CPS  
 -65°F TO 165°F  
 11.5 OZ.

NOTES:

1. TERMINAL SHIELD IS NOTCHED FOR DRAINAGE.
2. STAMP MONTH AND YEAR OF MFG ON CONTACTOR.
3. ITEMS 5, 6, 9, & 10 TO BE SILVER PLATED.
4. COVER MATERIAL IS ALUMINUM, PAINTED WITH BLACK LACQUER.
5. FAA/PMA PLATE (AND OVERLAY) NOT REQUIRED ON UNITS SUPPLIED TO ORIGINAL EQUIPMENT MANUFACTURERS.

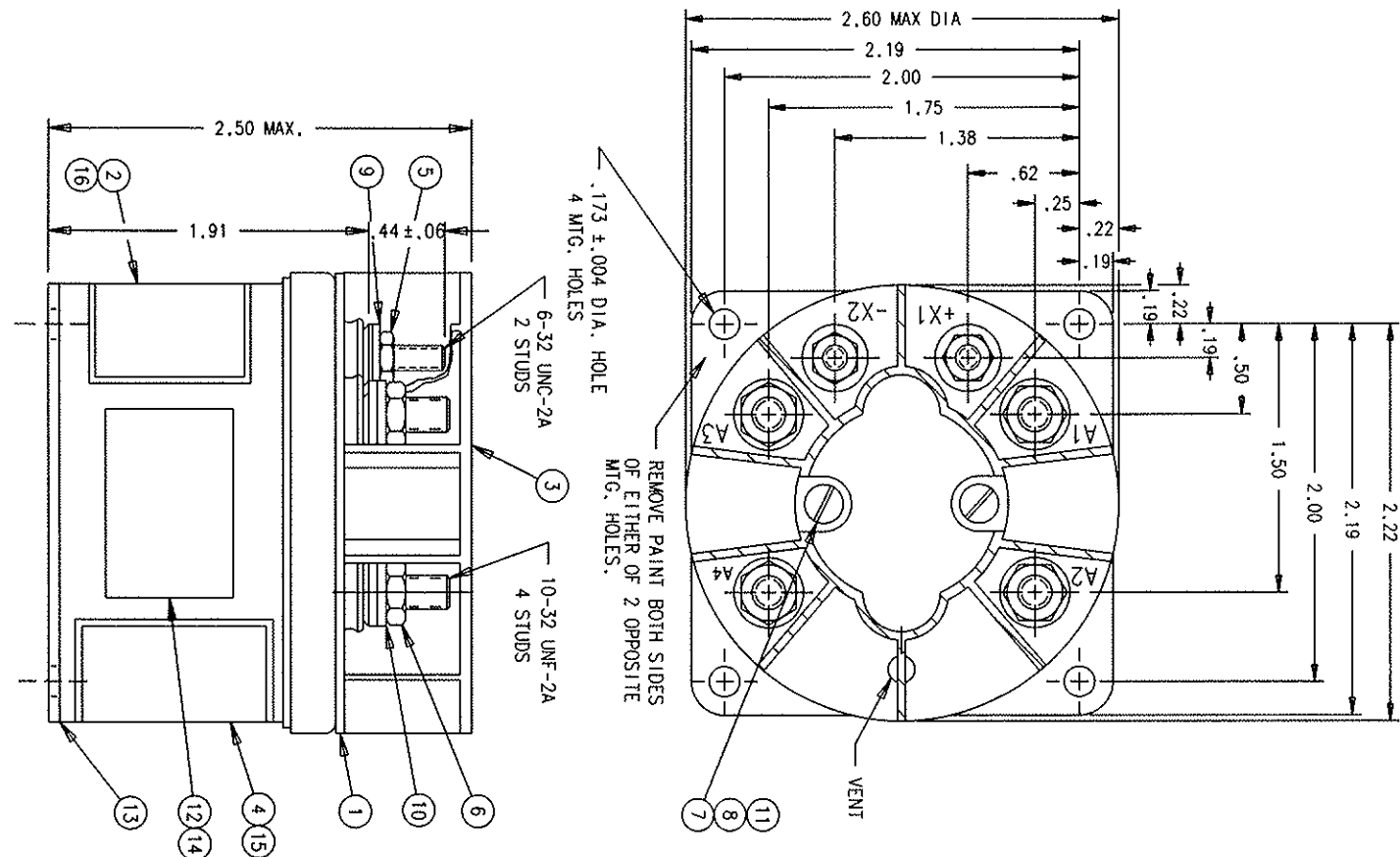
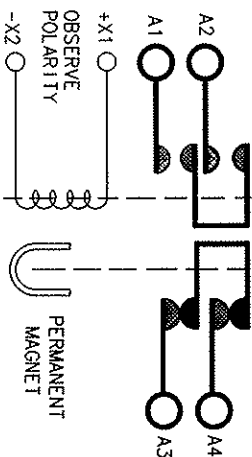

16	1	39529-026	OVERLAY				
15	1	39529-038 <th>OVERLAY</th> <td></td> <td></td> <td></td> <td></td>	OVERLAY				
14	1	39529-047 <th>OVERLAY</th> <td></td> <td></td> <td></td> <td></td>	OVERLAY				
13	1	37044-010 <td>CONTACTOR ASSEMBLY - PRIMARY</td> <td></td> <td></td> <td></td> <td></td>	CONTACTOR ASSEMBLY - PRIMARY				
12	1	58400-038 <td>PLATE - FAA/PMA</td> <td></td> <td></td> <td></td> <td></td>	PLATE - FAA/PMA				
11	2	51701-180 <td>WASHER - .015 X .103 X 3/16</td> <td></td> <td></td> <td></td> <td></td>	WASHER - .015 X .103 X 3/16				
10	4	51810-054 <td>WASHER-LOCK-NO.10 SPLIT TYPE</td> <td></td> <td></td> <td></td> <td></td>	WASHER-LOCK-NO.10 SPLIT TYPE				
9	2	51806-014 <td>WASHER-LOCK-NO.5 SPLIT TYPE</td> <td></td> <td></td> <td></td> <td></td>	WASHER-LOCK-NO.5 SPLIT TYPE				
8	2	51805-011 <td>WASHER-LOCK-NO.6 SPLIT TYPE</td> <td></td> <td></td> <td></td> <td></td>	WASHER-LOCK-NO.6 SPLIT TYPE				
7	2	51205-591 <td>SCREW - 5-40 X 3/8 RD. HD.</td> <td></td> <td></td> <td></td> <td></td>	SCREW - 5-40 X 3/8 RD. HD.				
6	4	50410-054 <td>NUT - 10-32 X 5/16 X 9/64 HEX.</td> <td></td> <td></td> <td></td> <td></td>	NUT - 10-32 X 5/16 X 9/64 HEX.				
5	2	50406-034 <td>NUT - 6-32 X 1/4 X 5/64 HEX</td> <td></td> <td></td> <td></td> <td></td>	NUT - 6-32 X 1/4 X 5/64 HEX				
4	1	16581-001 <td>PLATE - WIRING DIAGRAM</td> <td></td> <td></td> <td></td> <td></td>	PLATE - WIRING DIAGRAM				
3	1	15549-001 <td>SHIELD - TERMINAL</td> <td></td> <td></td> <td></td> <td></td>	SHIELD - TERMINAL				
2	1	16043-001 <td>PLATE - NAME</td> <td></td> <td></td> <td></td> <td></td>	PLATE - NAME				
1	1	15537-007 <td>PLATE - BASE COVER</td> <td></td> <td></td> <td></td> <td></td>	PLATE - BASE COVER				

FIND NO	QTY	PART OR IDENTIFYING NO	NOMENCLATURE OR DESCRIPTION	FSM NO	DRAWING OR SPECIFICATION	MATERIAL OR NOTE
16	1	39529-026	OVERLAY			
15	1	39529-038	OVERLAY			
14	1	39529-047	OVERLAY			
13	1	37044-010	CONTACTOR ASSEMBLY - PRIMARY			
12	1	58400-038	PLATE - FAA/PMA			
11	2	51701-180	WASHER - .015 X .103 X 3/16			
10	4	51810-054	WASHER-LOCK-NO.10 SPLIT TYPE			
9	2	51806-014	WASHER-LOCK-NO.5 SPLIT TYPE			
8	2	51805-011	WASHER-LOCK-NO.6 SPLIT TYPE			
7	2	51205-591	SCREW - 5-40 X 3/8 RD. HD.			
6	4	50410-054	NUT - 10-32 X 5/16 X 9/64 HEX.			
5	2	50406-034	NUT - 6-32 X 1/4 X 5/64 HEX			
4	1	16581-001	PLATE - WIRING DIAGRAM			
3	1	15549-001	SHIELD - TERMINAL			
2	1	16043-001	PLATE - NAME			
1	1	15537-007	PLATE - BASE COVER			

UNLESS OTHERWISE SPECIFIED DIMENSIONS ARE IN INCHES TOLERANCES ARE	DR BY	RLS	198/05/26
±.03	CHK BY	CS	8/16/96
±.010	ENGR	W	8/16/96
	MFG	W	8/16/96
	RELEASE		
	CONTR NO.		
	GOVT APPVL		

HARTMAN ELECTRICAL MANUFACTURING MANSFIELD, OHIO		CONTRACTOR - 2, SPST 1NO-1NC DB	
SIZE	CODE IDENT	DWG NO.	
C	74063	D-7AC	
SCALE	NONE		
			SHEET