

MAX14912 Peripheral Module

Evaluates: MAX14912

General Description

The MAX14912 peripheral module (MAX14912PMB) provides the hardware to evaluate the MAX14912 octal digital output driver. Refer to the MAX14912 IC data sheet for detailed information regarding operation of the IC.

The module can be used in various ways; Maxim sells a low-cost USB2PMB1#, USB2PMB2#, or USB2GPIO# adapter board that uses the Munich GUI software for communication through a USB cable. This is not included with this board. Alternatively, any microcontroller or FPGA with a 12-pin Pmod™-compatible connector can be used. Another option for the user is to wire-wrap a temporary connection from their system to the pins on connector X1.

The Pmod PCB dimension is just 50mm long x 20mm wide, with the width determined by the size of the X3 connector.

Contents

- MAX14912PMB# with the MAX14912

Features

- Easy Evaluation of the MAX14912
- High speed Push-Pull Digital Output
- High Side Switch option featuring Safe-Demagnetization for Safe Turn Off of Unlimited Inductance
- Works with USB2PMB2# or USB2GPIO# Adapter and Munich GUI Software

[Ordering Information](#) appears at end of data sheet.

MAX14912PMB

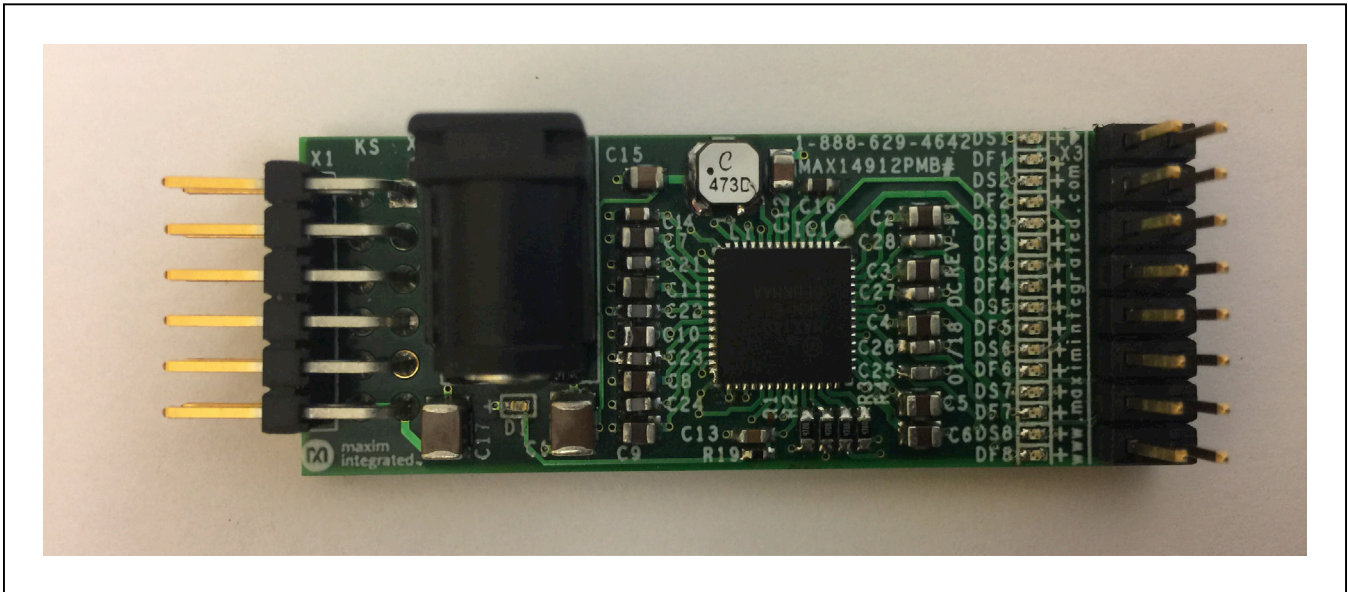

Pmod is a trademark of Digilent Inc.

System Diagram

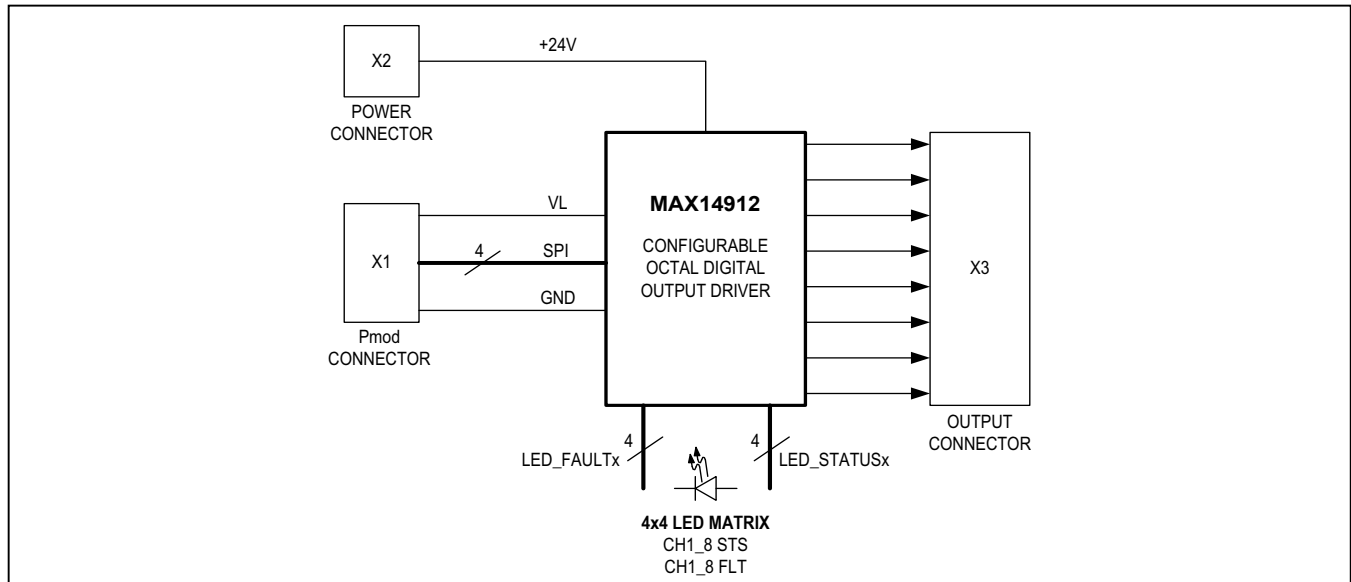

Figure 1. MAX14912PMB# Block Diagram

Quick Start Guide

Required Equipment

- MAX14912PMB#
- 24V DC supply (>3A recommended) - not supplied
- USB2PMB2# (or USB2GPIO#) adapter with Munich GUI and micro-USB Cable - not supplied
- Windows® 7, Windows 8.1 or Windows 10 PC with a spare USB port

Note: In the following sections, software-related items are identified by **bolding**. Text in **bold** refers to items directly from the EV system software. Text in **bold and underline** refers to items from the Windows operating system.

Procedure

If the USB2PMB1 or USB2PMB2 or USB2GPIO adapter is used, the user can download software by following the steps below to get started. In this description the USB2PMB2 adapter is used:

- 1) Visit www.maximintegrated.com/evkitsoftware to download the latest version of the Munich_GUI software, version 2.19 or later, Munich_GUISetupV2.19.ZIP.
- 2) Save the software to a temporary folder. Unzip the .ZIP file and double-click the .EXE file to run the installer. A message box asking **Do you want to allow the following program to make changes to this computer?** might appear. If so, click **Yes**.
- 3) The installer includes the drivers for the hardware and software. Follow the instructions on the installer and once complete, click **Finish**. The default location of the software is in the program files directory.
- 4) Connect the MAX14912PMB# Pmod connector X1 to the connector on USB2PMB2#.
- 5) Connect a 24V DC supply to MAX14912PMB# using barrel connector X2.
- 6) Connect the USB2PMB2# to the PC with the micro-USB cable. Windows should automatically recognize the device and display a message near the **System Icon** menu indicating that the hardware is ready to use.
- 7) Once the hardware is ready to use, launch the software. The status bar in the GUI should display **Disconnected** in the bottom right-hand corner. Go to the **Device** tab to select the MAX14912PMB#.
- 8) Click the button for each switch to set the corresponding output on (pin in high) or off (pin in Low) to set the MAX14912 outputs. Note that this board configures MAX14912 to be in Push-Pull mode. MAX14912 can be programmed, such that each individual output can be either Push-Pull or High-Side mode. In High-Side mode, the MAX14912 features fast and safe demag.

Windows is a registered trademark and registered service mark of Microsoft Corporation.

Detailed Description of Software

Connect to Hardware

The **Device** menu has options to search and connect to the hardware. Use the **Scan Adapters** option to search for the USB2PMB2 modules connected to the PC. If modules are found, the serial numbers of the modules are listed in the **USB2PMB2s** menu item. Select the serial number in the **USB2PMB2s** list to connect the software to communicate with that module. The software can only communicate to one module at a time only.

Setting MAX14912 Outputs

Each of the eight outputs are set as on or off by moving the corresponding button for the specific channel. Click the button for each switch to set the corresponding output on (pin in high) or off (pin in low) to set the MAX14912 outputs. When the output is on, the Green LED for that output is illuminated. If there is a fault, such as open load or undervoltage, the RED LED for that output is illuminated.

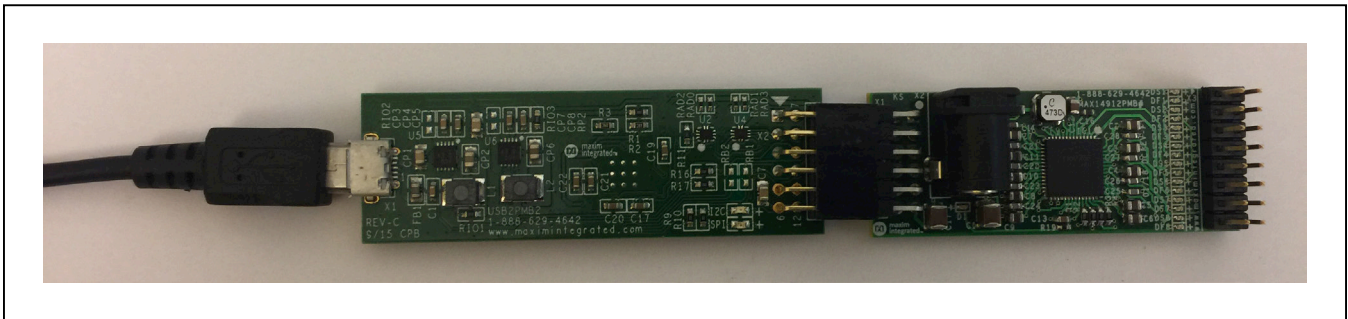

Figure 2. MAX14912PMB# connected to USB2PMB2#

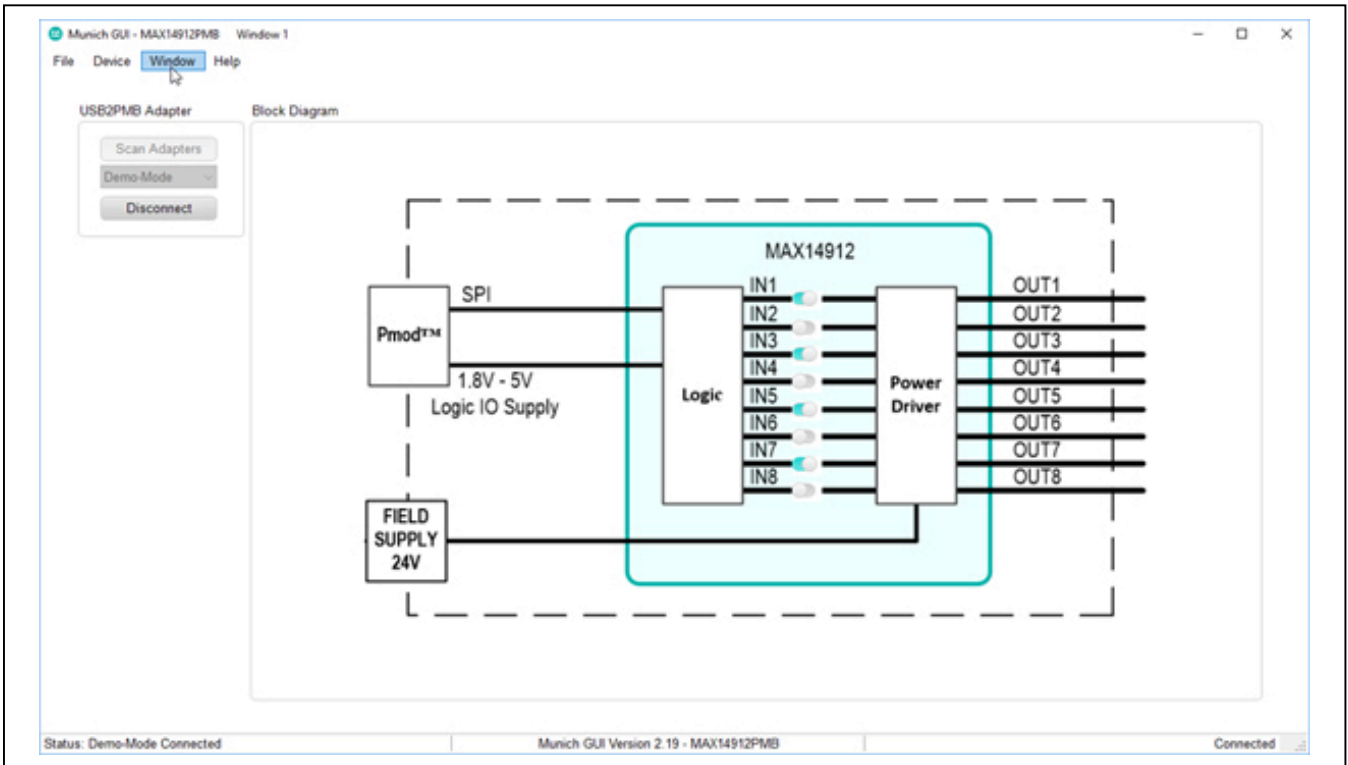

Figure 3. MAX14912PMB# Software (Munich GUI Tab)

Detailed Description of Hardware

The MAX14912PMB hardware provides everything needed to evaluate the MAX14912 using the SPI serial interface, and includes the MAX14912, a terminal for the 8 external loads, and a 24V DC power connector. An optional USB2PMB2 module can be used with the Munich GUI to provide the USB-to-MAX14912 interface to control the MAX14912. The USB2PMB2# adapter provide a 3.3V input from the USB interface providing V_L to MAX14912. Note an external 24V DC supply is required even if used with the USB2PMB2# and a USB cable.

Pmod Style Connector

The MAX14912PMB# can plug directly into a Pmod-compatible port through X1. Note the pin definitions are SPI, and the user must configure the microcontroller or FPGA to match MAX14912 signals. For more information on the interface and control, refer to the MAX14912 IC data sheet. See [MAX14912PMB Schematic](#) for the X1 pinout.

Ordering Information

PART	TYPE
MAX14912PMB#	Peripheral Module

#Denotes RoHS compliant.

External Supply

An external 24V DC supply is required to be connected to X2. The rating of this supply must be aligned to the load connected to X3.

LEDs

The 4 x 4 LED driver crossbar matrix offers a pin-optimized configuration for driving 16 LEDs. Per-channel output status and the fault conditions are indicated by individual LEDs, 8 Green LEDs for status and 8 Red LEDs for faults. If a FAULT LED is turned on for an output, the corresponding STATUS LED is always turned off. This mitigates false information about the status of the affected OUT_ pin.

External Loads

An output connector is provided for each output along with a GROUND signal. See [MAX14912PMB Schematic](#) for the X3 pinout.

MAX14912PMB EV Kit Bill of Materials

ITEM	QTY	REF DES	MAXINV	MFG PART #	MFG	VALUE	DESCRIPTION
1	2	C1, C17	20-0010U-BA76	C3225X7S1H106K250AB	TDK	10UF	CAPACITOR; SMT (1210); CERAMIC CHIP; 10UF; 50V; TOL=10%; TG=-55 DEGC TO +125 DEGC; TC=X7S
2	10	C2-C11	20-0001U-Z5	GK4J1X7C106K125;	TAIYO YUDEN	1.0UF	CAPACITOR; SMT (0805); CERAMIC; TUF; 35V; TOL=10%; MODEL=GMK SERIES; TG=-55 DEGC TO +125 DEGC; TC=X7R
3	2	C12, C15	20-0010U-BA19	GCM21BC71C106KE35	TDK/MURATA	10UF	CAPACITOR; SMT (0805); CERAMIC CHIP; 10UF; 16V; TOL=10%; TG=-55 DEGC TO +125 DEGC; TC=X7S; AUTO
4	2	C13, C14	20-0001U-01	CC0603KR7R0BB104	YAGEO	0.1UF	CAPACITOR; SMT (0603); CERAMIC CHIP; 0.1UF; 100V; TOL=10%; TG=-55 DEGC TO +125 DEGC; TC=X7R
5	1	C16	20-00U22-91	GRM188F51H224ZA01D	MURATA	0.22UF	CAPACITOR; SMT (0603); CERAMIC CHIP; 0.22UF; 50V; TOL=20%; MODEL=Y5V; TG=-55 DEGC TO +125 DEGC; TC=+
6	8	C21-C28	20-00U01-M3	CGA3EANP02A103J080AC	TDK	0.01UF	CAPACITOR; SMT (0603); CERAMIC CHIP; 0.01UF; 100V; TOL=5%; MODEL=MULTILAYER CERAMIC CHIP CAPACITOR; TC=NPO
7	9	D1, DS1-DS8	30-SMLP12PT-00	SML-P12PT	ROHM	SML-P12PT	DIODE; LED; SML-P1 SERIES; ULTRA COMPACT HIGH BRIGHTNESS LED; GREEN; SMT (0402); VF=2.2V; IF=0.02A
8	8	DF1-DF8	30-SMLP12UT-00	SML-P12UT	ROHM	SML-P12UT	DIODE; LED; SML-P1 SERIES; ULTRA COMPACT HIGH BRIGHTNESS LED; RED; SMT (0402); VF=2V; IF=0.02A
9	1	IC1	10-MAX14912AKN-T	MAX14912AKN+	MAXIM	MAX14912AKN+	SMT (0402); VF=2V; IF=0.02A
10	1	L1	50-0047U-S10	LPS4018-473MR	COILCRAFT	47UH	IC; SWTC; OCTAL HIGH-SPEED; HIGH-SIDE SWITCH/PUSH-PULL DRIVER; TQFN56-EP
11	4	R1-R4	80-0470R-24	CRCW0603470RFK; ERJ-3EKF4700	VISHAY DALE; PANASONIC	470	INDUCTOR; SMT; FERRITE BOBBIN CORE; 47UH; TOL=+/-20%; 0.56A
12	1	R19	80-0001K-23	CRCW04021K00FK; RC0402FR-071KL	VISHAY DALE; YAGEO PHICOMP	1K	RESISTOR; 0603; 470 OHM; 1%; 100PPM; 0.10W; THICK FILM
13	1	X1	TSW10608SDRA12P-17	TSW-106-08-S-D-RA	SAMTEC	TSW-106-08-S-D-RA	CONNECTOR; THROUGH HOLE; POST TERMINAL STRIP ASSEMBLY; RIGHT ANGLE; 12PINS; NOTE: ALTERNATE PIN NUMBERING
14	1	X2	01-PJ202AH3P-27	PJ-202AH	CUJ INC. SULLINS ELECTRONICS CORP.	PJ-202AH	CONNECTOR; MALE; THROUGH HOLE; DC POWER JACK; RIGHT ANGLE; 3PINS
15	1	X3	01-PBC08DAAN16P-21	PBC08DAAN	MAXIM	PBC08DAAN	CONNECTOR; MALE; THROUGH HOLE; BREAKAWAY; STRAIGHT; 16PINS; -65 DEGC TO +125 DEGC
16	1	PCB	N/A	MAX14912PMB_DEMO_B	MAXIM	PCB	PCB:MAX14912PMB_DEMO_B
TOTAL	53						
DO NOT PURCHASE(DNPF)							
ITEM	QTY	REF DES	MAXINV	MFG PART #	MFG	VALUE	DESCRIPTION
TOTAL	0						
PACKOUT (These are purchased parts but not assembled on PCB and will be shipped with PCB)							
ITEM	QTY	REF DES	MAXINV	MFG PART #	MFG	VALUE	DESCRIPTION
1	1	PACKOUT_BOX	88-00711-SML	88-00711-SML	N/A	N/A	BOX: SMALL BROWN 9.316X7.114 - PACKOUT
2	1	PACKOUT_BOX	87-02162-00	87-02162-00	N/A	N/A	ESD BAG: BAG: STATIC SHIELD ZIP 4inX6in; W/ESD LOGO - PACKOUT
3	1	PACKOUT_BOX	85-MAXKIT-PNK	85-MAXKIT-PNK	N/A	N/A	PINK FOAM: FOAM: ANTISTATIC PE 12inX12inX5MMI - PACKOUT
4	1	PACKOUT_BOX	EVINSERT	EVINSERT	N/A	N/A	WEB INSTRUCTIONS FOR MAXIM DATA SHEET
5	1	PACKOUT_BOX	85-84003-006	85-84003-006	N/A	N/A	LABEL(EV KIT BOX) - PACKOUT
TOTAL	5						

MAX14912PMB Schematic

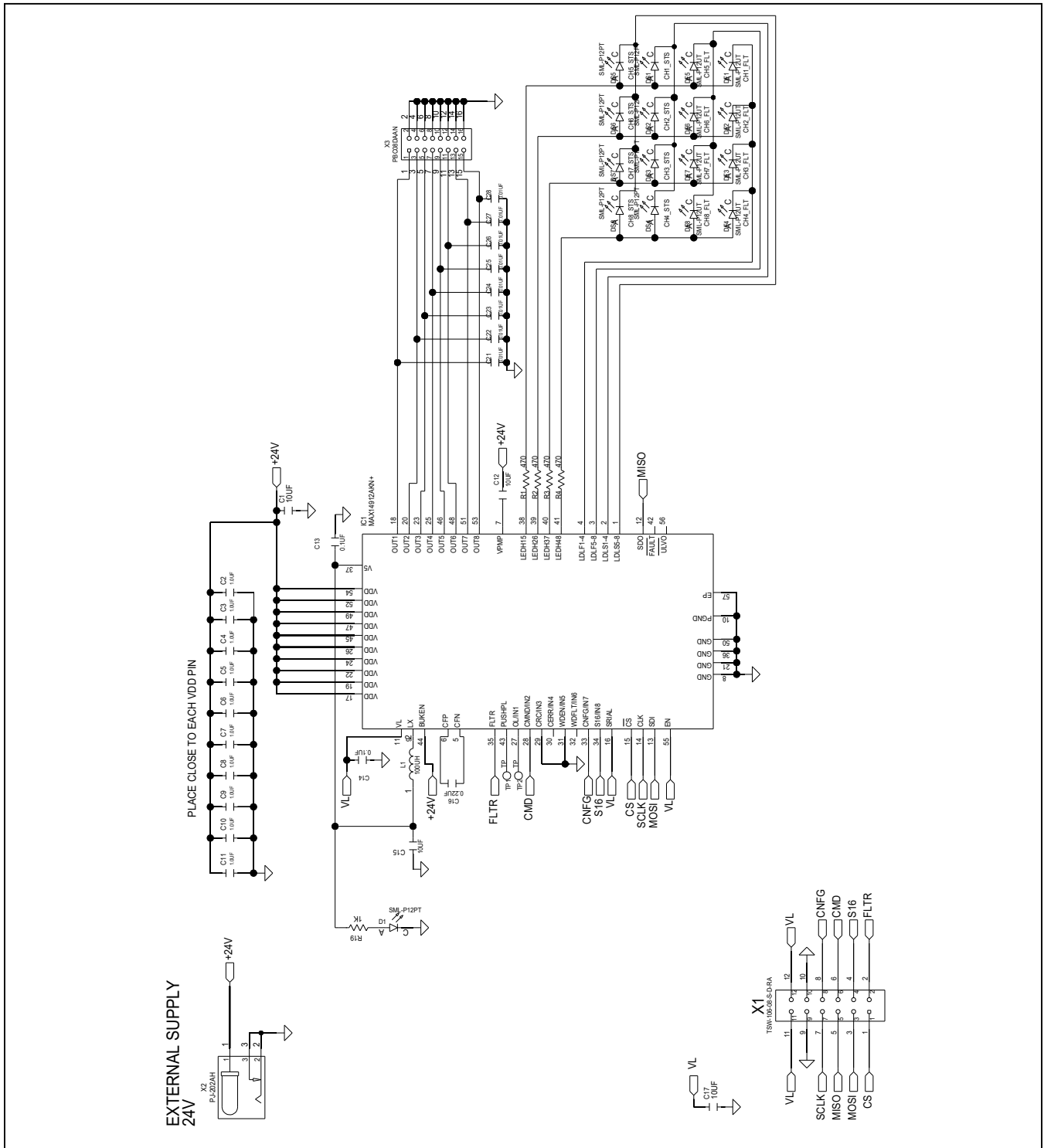

MAX14912PMB PCB Layout Diagram

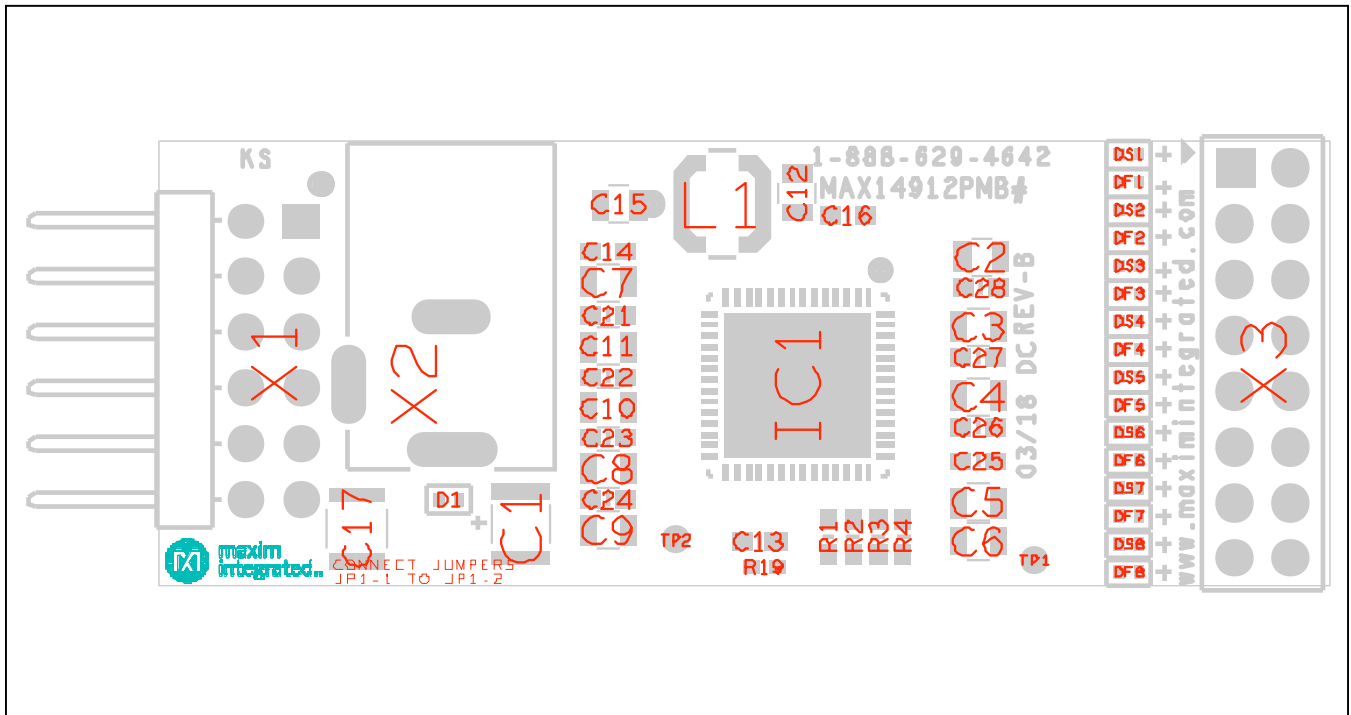

MAX14912PMB# PCB Layout—Top Silkscreen

Revision History

REVISION NUMBER	REVISION DATE	DESCRIPTION	PAGES CHANGED
0	5/18	Initial release	—

For pricing, delivery, and ordering information, please contact Maxim Direct at 1-888-629-4642, or visit Maxim's website at www.maximintegrated.com.

Maxim Integrated cannot assume responsibility for use of any circuitry other than circuitry entirely embodied in a Maxim Integrated product. No circuit patent licenses are implied. Maxim Integrated reserves the right to change the circuitry and specifications without notice at any time. The parametric values (min and max limits) shown in the Electrical Characteristics table are guaranteed. Other parametric values quoted in this data sheet are provided for guidance.