

APPROVED: _____
 DATE: _____ TITLE: _____

| Rev | AWO # | Description | Date | Appr |
|-----|-------|--------------|----------|-------|
| - | | RELEASED | 11/1/22 | |
| A | | UPDATE SPEC. | 11/30/22 | WX/RC |

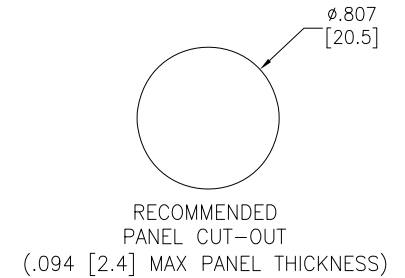
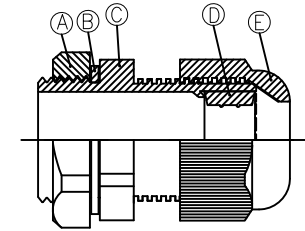
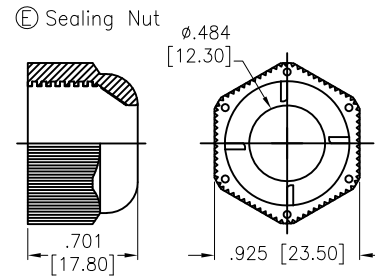
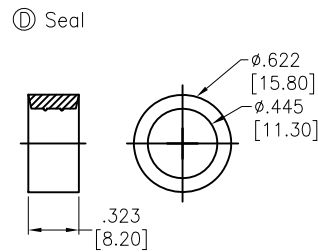
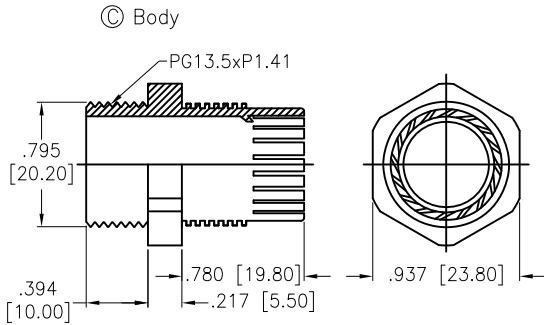
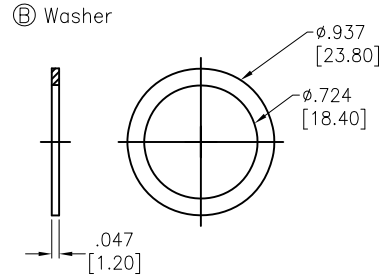
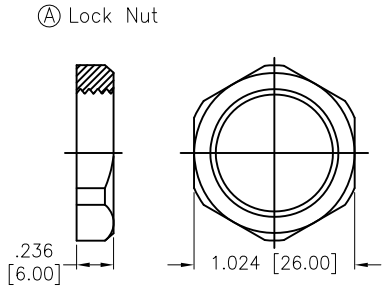

SPECIFICATIONS:

Material:
 Lock Nut: PA66, rated UL 94V-2
 Body: PA66, rated UL 94V-2
 Sealing Nut: PA66, rated UL 94V-2
 Washer: Nitrile Butylene
 Seal: Nitrile Butylene

Mechanical:
 Cable range O.D.: $\phi .236 \sim \phi .433 [6.00 \sim 11.00\text{mm}]$
 Nut Torque: 2Nm Max.

Environmental:
 Waterproof: IP68

Lead free, RoHS compliant.



| | | |
|--|-------|---------|
| UNLESS OTHERWISE SPECIFIED ALL DIMENSIONS ARE INCHES [MM]. TOLERANCES: EXCEPT AS NOTED | | |
| INCHES | HOLES | |
| .X ± .10 | ∅X | ± .10 |
| .XX ± .020 | ∅XX | ± .015 |
| .XXX ± .015 | ∅XXX | ± .010 |
| DRAWN | LH | 11/1/22 |
| CHECKED | RC | 11/1/22 |
| APPROVED | | |
| THIS DRAWING CONTAINS INFORMATION THAT IS PROPRIETARY AND SHOULD NOT BE USED WITHOUT PRIOR WRITTEN PERMISSION FROM ADAM TECH | | |

ADAM TECH
 909 Rahway Avenue,
 Union, NJ 07083
 Phone: 908-687-5000
 Fax: 908-687-5710

| | | |
|--|-----------------------|--------------|
| TITLE WATERPROOF CONNECTOR, PG13.5, 1 HOLE, CABLE GLAND, WATERPROOF: IP68 | | |
| SIZE X | PART NO. CG-P-13.5 | REV. A |
| REF: S00211C | SCALE: NTS | SHEET 1 OF 1 |