

PART NUMBER	REV	FIRST USED
680569-1	A	122500-1
680569-2	A	565435-5
680569-3	A	354500-1

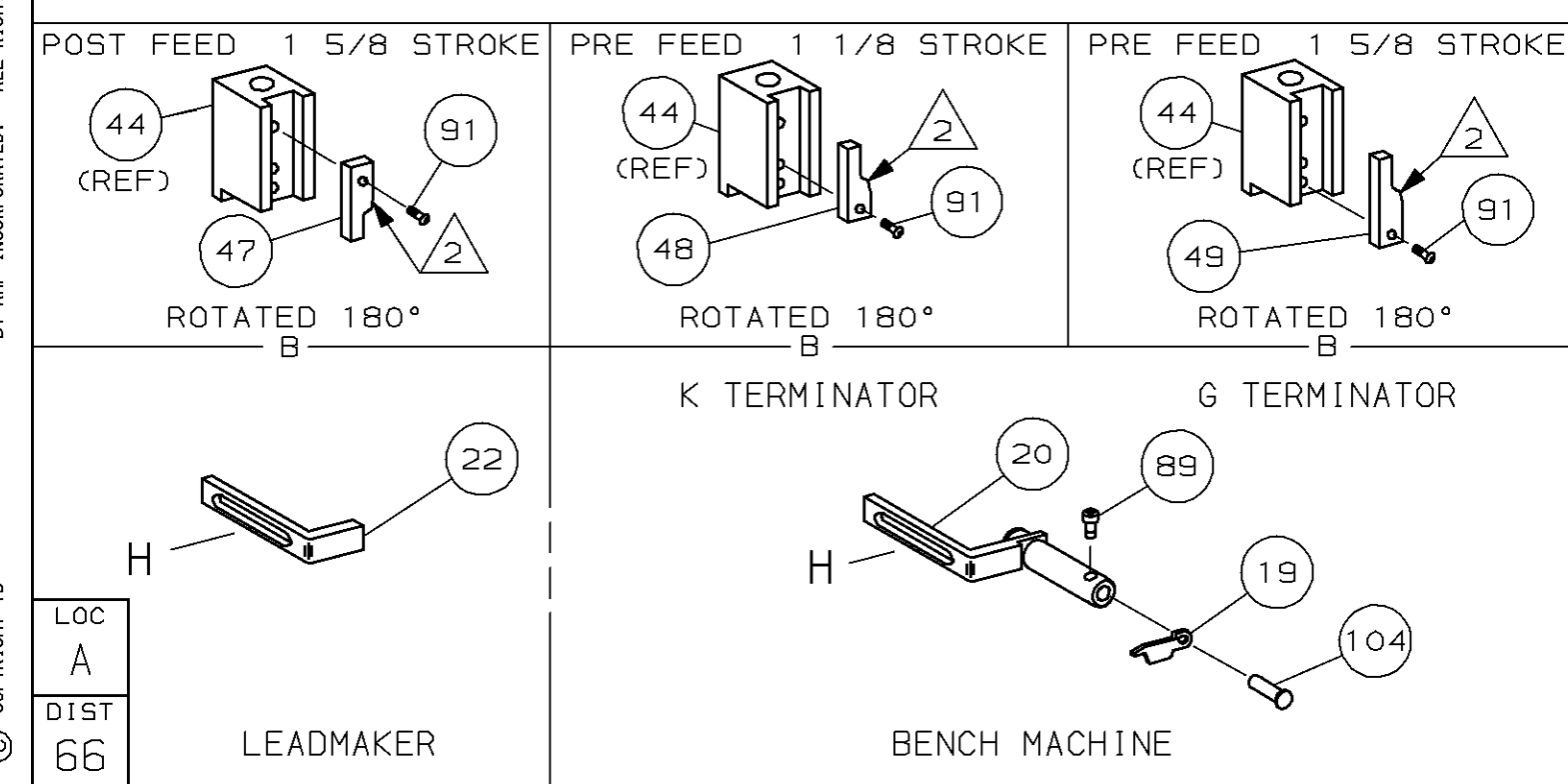
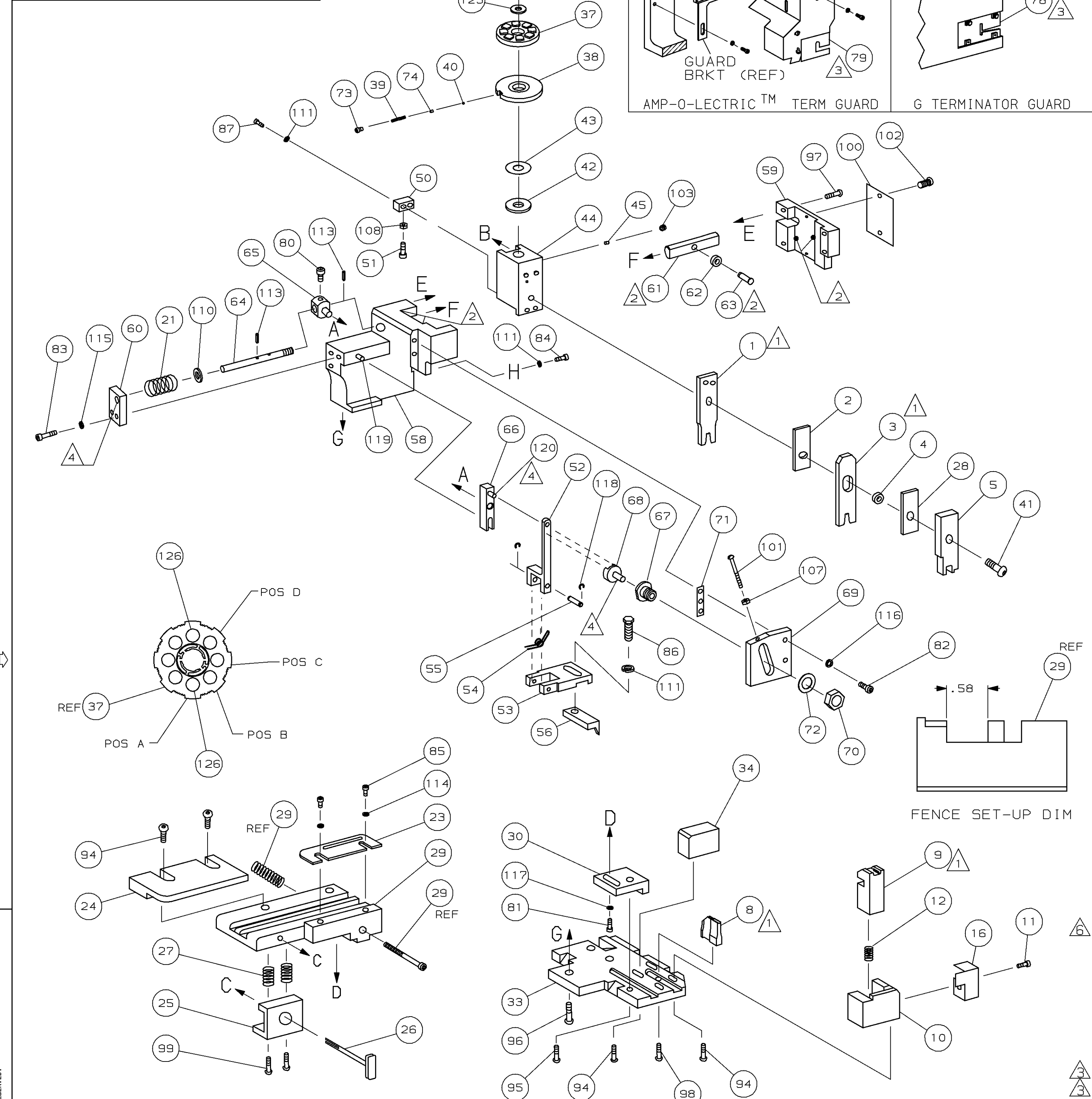

- 1 RECOMMENDED SPARE PARTS.
- 2 GREASE LIGHTLY.
- 3 GUARD MUST BE IN PLACE WHEN OPERATING APPLICATOR IN A BENCH MACHINE.
- 4 LUBRICATE DAILY USING NO. 20 MACHINE OIL.
- 5. ITEMS WITH QTY OF REF SPECIFIED (EXCEPT ITEMS 78 AND 79) ARE USED ON ITEM 46.
- 6 CUT TO LENGTH AT ASSY

TERMINAL NAME: RECEPTACLE			
286677	CRIMP DATA (COMP TERMINAL-CUST SPEC)		
PAD LTR	CRIMP HEIGHT	WIRE SIZE	
A	.033 ±.002 [0.84 ±0.05mm]	22	
B	NOT	USED	
C	NOT	USED	
D	NOT	USED	
CRIMP	SIZE	TYPE	RANGE
WIRE	.070 [1.78mm]	F	22
INSUL	.100 [2.54mm]	0	∅.055-.079

QTY REQD PER ASSY	TERM APPL	SPEC	FEED	APPL INSTRUCTION	SET UP GAGE	LAYOUT	ITEM NO
.188-.219	NONE		.397	408-8040	458637-1	L2021	129
2	2	2	-	C	5-354779-6		126
1	1	1	-	A	986950-1		125
1	1	1	-	A	217238-1		124
1	1	1	-	-	4088040		123
REF	REF	REF	-	A	1-21030-1		120
REF	REF	REF	-	A	1-21030-6		119
REF	REF	REF	-	A	21045-3		118
1	1	1	-	A	21024-5		117
REF	REF	REF	-	A	21024-5		116
REF	REF	REF	-	A	21024-5		115
2	2	2	-	A	21024-2		114
REF	REF	REF	-	A	5-21028-1		113
4	4	4	-	A	21024-4		112
REF	REF	REF	-	A	21899-4		110
1	1	1	-	A	21018-5		109
REF	REF	REF	-	A	21068-5		107
1	1	1	-	A	992031-1		105
1	1	1	-	A	21009-2		104
2	2	2	-	A	21017-2		103
REF	REF	REF	-	A	6-23715-5		102
1	1	1	-	B	461264-1		100
2	2	2	-	A	3-21002-0		99
1	1	1	-	A	22733-8		98
REF	REF	REF	-	A	2-21002-9		97
REF	REF	REF	-	A	2-22733-8		96
REF	REF	REF	-	A	2-21002-7		95
6	6	6	-	A	2-21002-2		94
1	1	1	-	A	1-21002-7		93
1	1	1	-	A	1-21002-7		92
1	1	1	-	A	1-21002-7		91
1	1	1	-	A	7-21000-9		90
1	1	1	-	A	7-21000-9		89
2	2	2	-	A	2-21000-7		88
1	1	1	-	A	2-22603-0		87
2	2	2	-	A	1-21000-3		86
1	1	1	-	A	2-21000-7		85
REF	REF	REF	-	A	3-21000-7		84
REF	REF	REF	-	A	3-21000-6		83
1	1	1	-	A	7-21000-6		82
REF	REF	REF	-	A	3-21000-4		81
-	REF	-	-	B	455749-1		80
REF	-	-	-	B	679532-1		79
							78
							77
							76
							75
1	1	1	-	A	690603-1		74
1	1	1	-	A	23030-1		73
REF	REF	REF	-	A	458109-1		72
REF	REF	REF	-	A	690517-1		71
-3	-2	-1	U/M	DWG SIZE	PART NO	DESCRIPTION	ITEM NO

QTY REQD PER ASSY	LEADMAKER	MECH POST FEED	MECH PRE FEED	ITEM NO			
-1	LEADMAKER	MECH POST FEED	MECH PRE FEED				
-2	BENCH MODEL K	MECH PRE FEED					
-3	BENCH MODEL G	MECH PRE FEED					
REF	REF	REF	-	B	22594-8	NUT, HEX (1/2-20)	70
REF	REF	REF	-	B	240628-1	PLATE, ADJUSTMENT	69
REF	REF	REF	-	B	240626-1	SHAFT, PIVOT	68
REF	REF	REF	-	B	240633-1	BUSHING	67
REF	REF	REF	-	A	455680-1	LEVER, INTERMEDIATE	66
REF	REF	REF	-	B	240629-1	BLOCK, PIVOT	65
REF	REF	REF	-	A	240632-2	SCREW, ADJ FEED ROD	64
REF	REF	REF	-	B	240659-3	PIN, CAM ROLLER	63
REF	REF	REF	-	B	240658-1	ROLLER, CAM	62
REF	REF	REF	-	B	454398-2	ROD, FEED	61
REF	REF	REF	-	A	454178-1	GUIDE, FEED ROD	60
REF	REF	REF	-	C	454220-1	CAP, RAM	59
REF	REF	REF	-	D	454485-1	HOUSING	58
							57
1	1	1	-	B	690542-2	PAWL, FEED	56
REF	REF	REF	-	B	240624-1	PIN, FEED FINGER	55
REF	REF	REF	-	B	691499-1	SPRING, FEED FINGER	54
REF	REF	REF	-	B	690541-1	HOLDER, FEED FINGER	53
REF	REF	REF	-	A	455679-1	LEVER, TERMINAL FEED ARM	52
1	1	1	-	A	811242-2	BUMPER, HOLDDOWN	51
1	1	1	-	A	690753-1	SPACER, TONKER	50
1	-	-	-	B	690602-6	CAM, PRE-FEED 1 5/8 ST	49
-	1	-	-	B	690602-5	CAM, PRE-FEED 1 1/8 ST	48
-	-	-	-	B	690501-4	CAM, POST-FEED 1 5/8 ST	47
1	1	1	-	B	459456-1	APPLICATOR, BASIC (SUBASSY)	46
1	1	1	-	A	690191-1	PLUG, NYLON	45
1	1	1	-	C	455673-1	RAM	44
1	1	1	-	A	690125-1	WASHER, LAMINATED	43
1	1	1	-	A	690124-1	WASHER, RAM	42
1	1	1	-	A	7-21002-9	BOLT, CRIMPER (5/16x1.00)	41
1	1	1	-	A	23241-6	BALL, STEEL	40
1	1	1	-	A	690170-1	SPRING, COMPRESSION	39
1	1	1	-	C	690142-1	DISC, INSULATION	38
1	1	1	-	D	354777-1	WIRE DISC, PLASTIC	37
1	1	1	-	A	22480-5	WASHER, SPRING	36
1	1	1	-	B	690212-1	POST, RAM	35
1	1	1	-	B	690786-1	SUPPORT, TERMINAL	34
REF	REF	REF	-	D	455675-1	PLATE, BASE	33
							32
							31
REF	REF	REF	-	B	455689-1	BLOCK, STRIP GUIDE ADJ	30
1	1	1	-	C	318042-1	STRIP GUIDE PLATE ASSY	29
1	1	1	-	C	2-455888-2	SPACER, FRONT SHEAR DEP	28
2	2	2	-	A	1-22284-0	SPRING, DRAG	27
1	1	1	-	B	690546-1	LEVER, DRAG RELEASE	26
1	1	1	-	B	240792-1	DRAG, TERMINAL	25
1	1	1	-	D	6-690504-8	GUIDE, STRIP (REAR)	24
1	1	1	-	A	690438-1	GUIDE, STRIP (FRONT)	23
-	-	1	-	B	690472-2	STRIPPER	22
REF	REF	REF	-	A	4-22284-9	SPRING, FEED RETURN	21
1	1	1	-	A	679218-1	STRIPPER WIRE STOP ASSY	20
1	1	1	-	B	458949-1	STRIPPER	19
							18
							17
1	1	1	-	B	318563-1	GUARD, CHIP, FRONT	16
							15
							14
							13
1	1	1	-	A	5-22280-0	SPRING, SHEAR	12
1	1	1	-	B	690461-1	STOP, SHEAR	11
1	1	1	-	C	690459-1	HOLDER, SHEAR (FRONT)	10
1	1	1	-	C	462006-7	SHEAR, FLOAT (FRONT)	9
1	1	1	-	C	662185-8	ANVIL	8
							7
							6
1	1	1	-	C	2-455889-0	DEPRESSOR, SHEAR (FRONT)	5
1	1	1	-	B	238011-6	SPACER, BLOCK CRIMPER	4
1	1	1	-	C	4-456135-7	CRIMPER, INSULATION	3
1	1	1	-	C	455888-8	SPACER, CRIMPER	2
1	1	1	-	C	3-456404-9	CRIMPER, WIRE	1
-3	-2	-1	U/M	DWG SIZE	PART NO	DESCRIPTION	ITEM NO