

Customer Information Sheet

DRAWING No.: M22-655XX42R

IF IN DOUBT - ASK

©

NOT TO SCALE

THIRD ANGLE PROJECTION

ALL DIMENSIONS IN mm

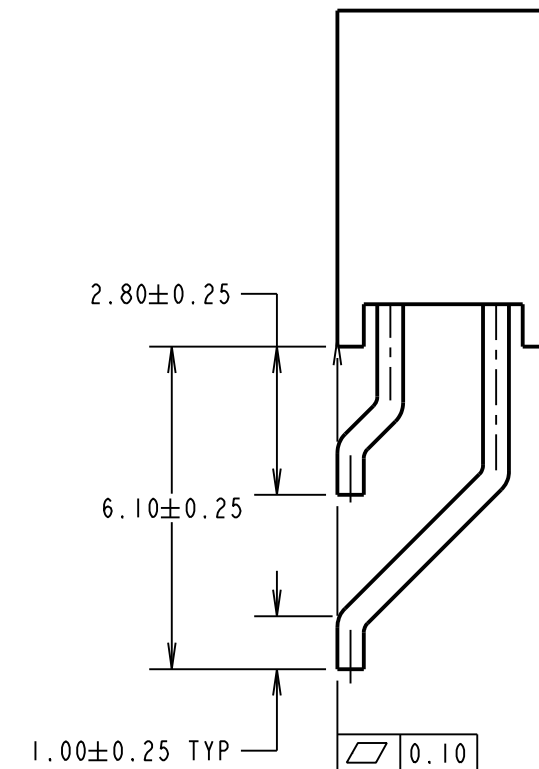
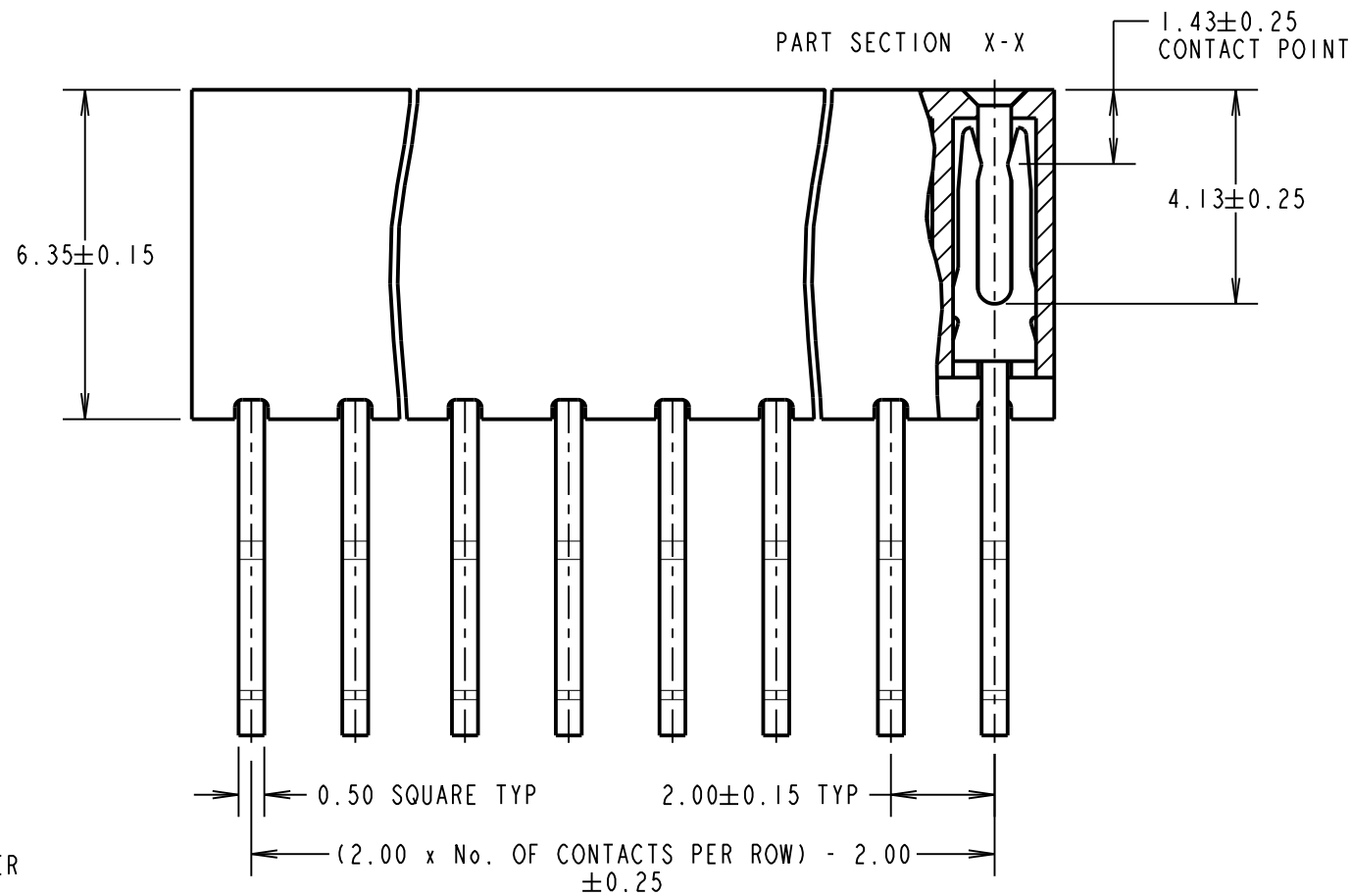
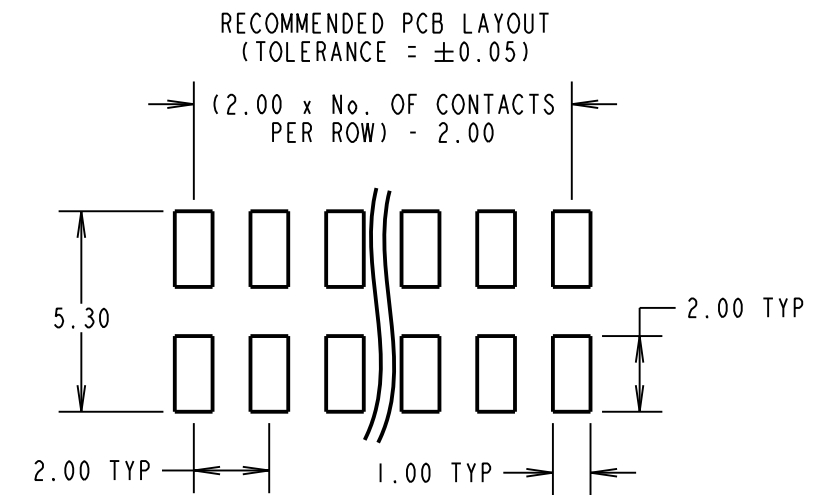
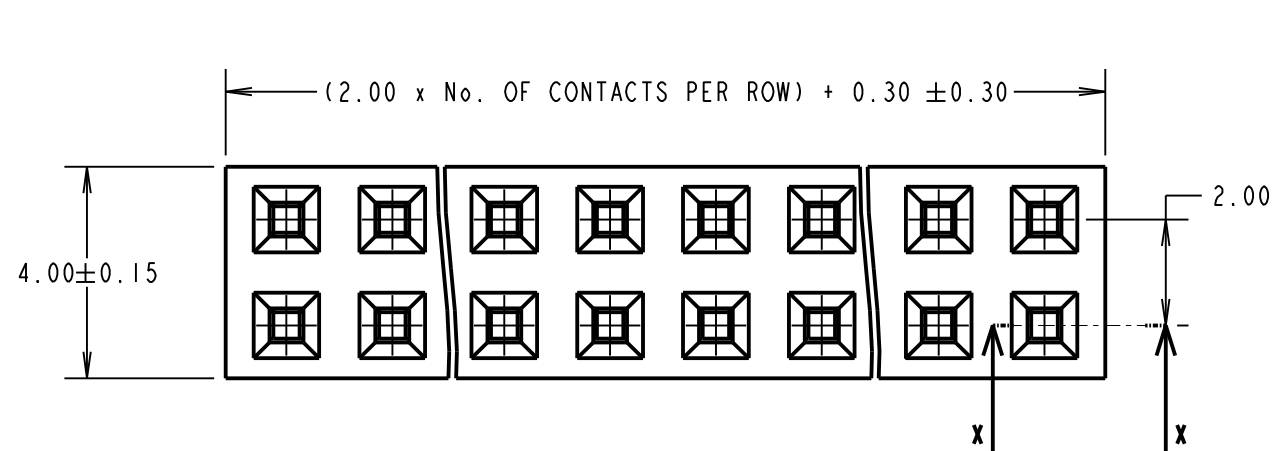

ORDER CODE:

M22-655XX42R

No. OF CONTACTS PER ROW: _____
02-06, 08, 10

COMPONENT SPECIFICATIONS:

- MATERIAL:**
 MOULD = GLASS FILLED LCP, UL94V-0
 CONTACTS = PHOSPHOR BRONZE
- FINISH:**
 CONTACT = 0.015µm MIN GOLD FLASH OVER
 0.76-2.03µm NICKEL
 TAIL = 2.03-5.08µm TIN OVER 0.76-2.03µm NICKEL
- ELECTRICAL:**
 CURRENT RATING = 2A
 CONTACT RESISTANCE = 20mΩ MAX
 INSULATION RESISTANCE = 1000MΩ MIN
 VOLTAGE PROOF = 500V AC FOR ONE MINUTE
- MECHANICAL:**
 INSERTION FORCE = 1.96N MAX PER CONTACT
 WITHDRAWAL FORCE = 0.19N MIN PER CONTACT
 DURABILITY = 300 CYCLES MIN
- ENVIRONMENTAL:**
 OPERATING TEMPERATURE = -40°C TO +105°C

NOTES:
1. FOR TAPE AND REEL DETAILS, SEE SHEET 4.

MGP	2	28.01.19	21764
NAME	ISS.	DATE	C/NOTE
APPROVED: MGP			
CHECKED: RP			
DRAWN: M.PERREN			
CUSTOMER REF.:			
ASSEMBLY DRG:			

HARWIN

www.harwin.com
technical@harwin.com

THIS DRAWING AND ANY INFORMATION OR DESCRIPTIVE MATTER SET OUT HEREON ARE CONFIDENTIAL AND COPYRIGHT PROPERTY OF THE HARWIN GROUP AND MUST NOT BE DISCLOSED, LOANED, COPIED OR USED FOR MANUFACTURING, TENDERING OR FOR ANY OTHER PURPOSE WITHOUT THEIR WRITTEN PERMISSION.

TOLERANCES
 X. = ±1mm
 X.X = ±0.50mm
 X.XX = ±0.10mm
 X.XXX = ±0.01mm
 ANGLES = ±5°
 UNLESS STATED

MATERIAL:
SEE ABOVE

FINISH: SEE ABOVE

S/AREA: mm²

TITLE:
2.00mm PITCH DIL HORIZONTAL SOCKET, SMT TAPE & REEL

DRAWING NUMBER:
M22-655XX42R

SHT
3
OF
4

Customer Information Sheet

DRAWING No.: M22-655XX42R

IF IN DOUBT - ASK

©

NOT TO SCALE

THIRD ANGLE PROJECTION

ALL DIMENSIONS IN mm

TAPE DETAILS FOR
02, 03, 04, 05 & 06 WAYS ONLY

TAPE DETAILS FOR
08 & 10 WAY ONLY

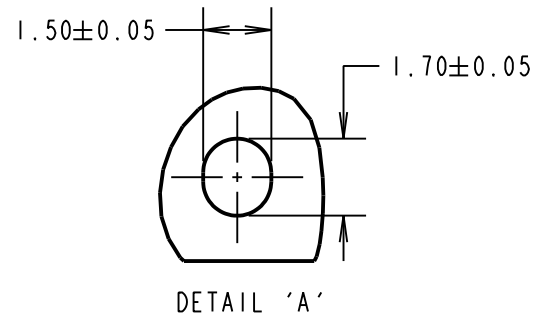
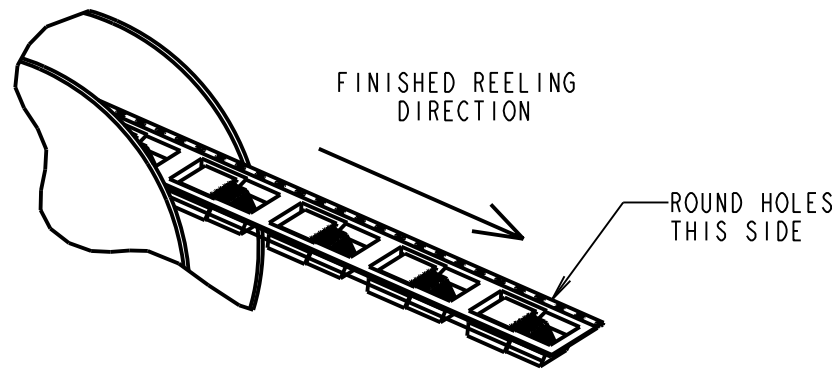
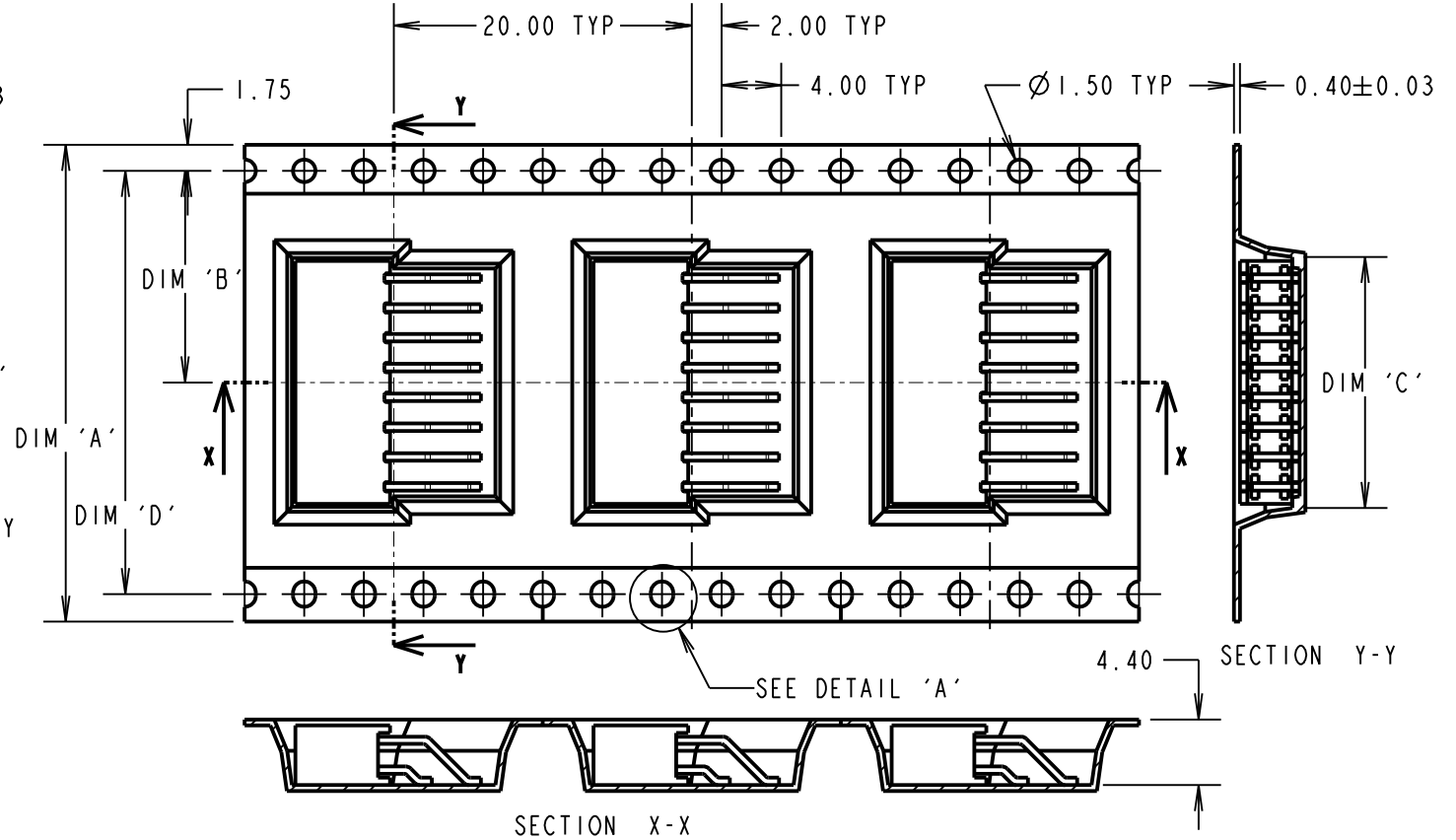
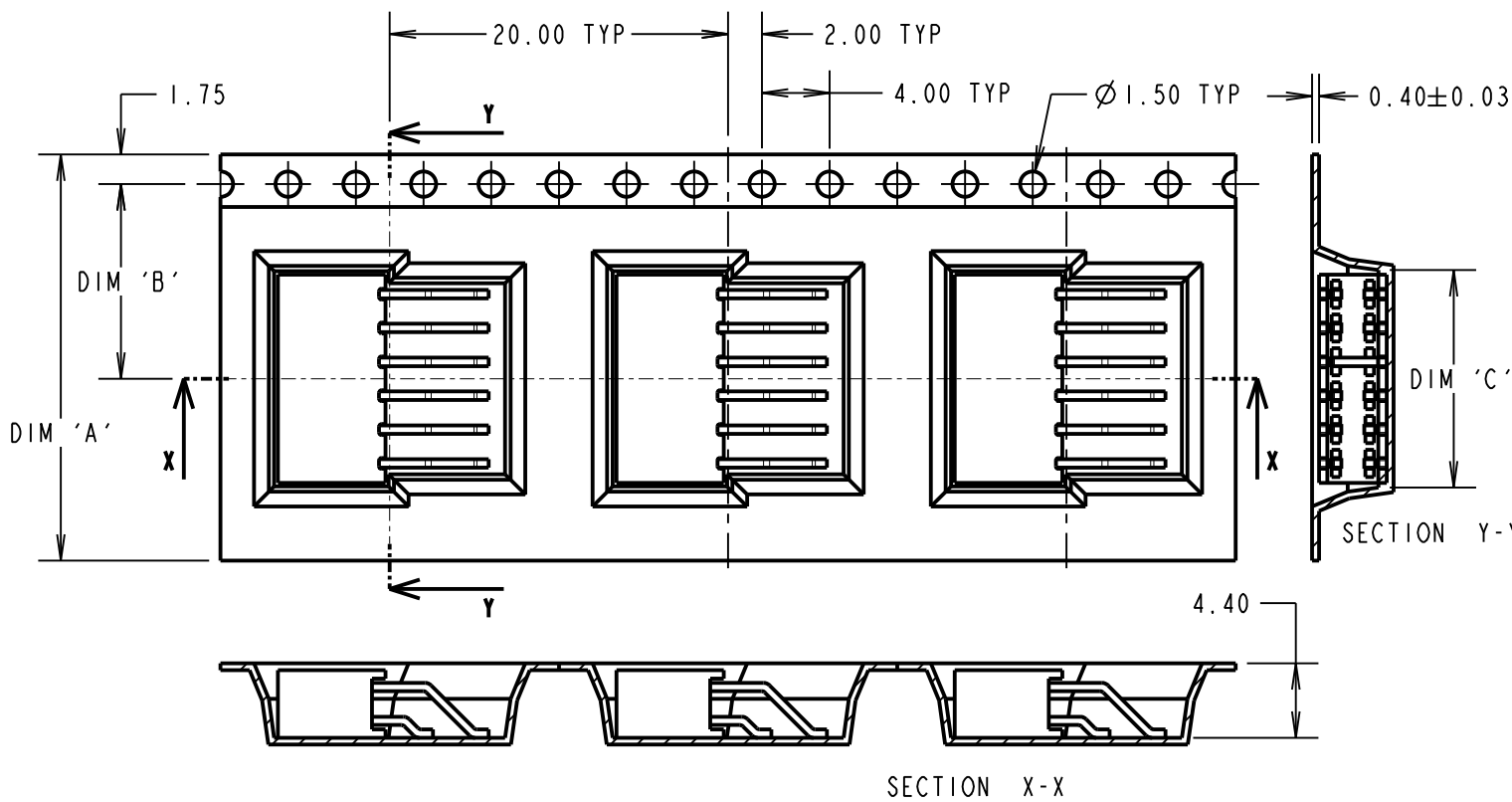

REEL DETAILS

PART No.	DIMENSION				REEL QUANTITY
	DIM 'A'	DIM 'B'	DIM 'C'	DIM 'D'	
M22-6550242R	16.00 ± 0.30	7.50 ± 0.15	4.70	N/A	750
M22-6550342R	24.00	11.50 ± 0.15	6.70		
M22-6550442R			8.70		
M22-6550542R			10.70		
M22-6550642R			12.70		
M22-6650842R	32.00 ± 0.30	14.20 ± 0.15	16.70	28.40 ± 0.15	
M22-6651042R	44.00 ± 0.30	20.20 ± 0.15	20.70	40.40	

MGP	2	28.01.19	21764
NAME	ISS.	DATE	C/NOTE
APPROVED: MGP			
CHECKED: RP			
DRAWN: M.PERREN			
CUSTOMER REF.:			
ASSEMBLY DRG:			

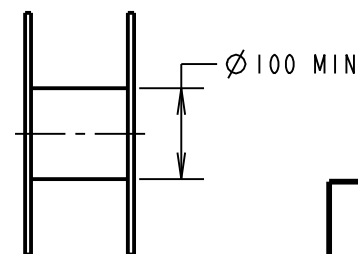
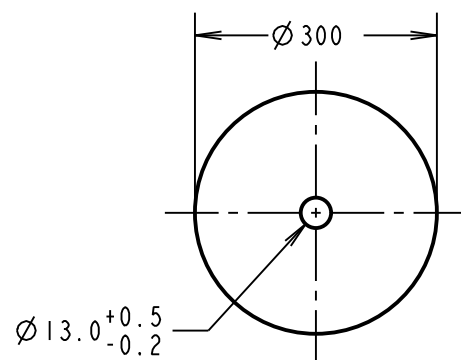

- NOTES:
1. PRODUCT IS TAPE AND REELED IN GENERAL ACCORDANCE WITH EIA-481 (ELECTRONIC INDUSTRIES ASSOCIATION).
2. FOR CONNECTOR DETAILS AND SPECIFICATIONS, SEE SHEET 3.

 www.harwin.com technical@harwin.com	THIS DRAWING AND ANY INFORMATION OR DESCRIPTIVE MATTER SET OUT HEREON ARE CONFIDENTIAL AND COPYRIGHT PROPERTY OF THE HARWIN GROUP AND MUST NOT BE DISCLOSED, LOANED, COPIED OR USED FOR MANUFACTURING, TENDERING OR FOR ANY OTHER PURPOSE WITHOUT THEIR WRITTEN PERMISSION.	TOLERANCES X. = ±1mm X.X = ±0.50mm X.XX = ±0.10mm X.XXX = ±0.01mm ANGLES = ±5° UNLESS STATED	MATERIAL: SEE SHEET 3 FINISH: SEE SHEET 3 S/AREA: mm ²	TITLE: 2.00mm PITCH DIL HORIZONTAL SOCKET, SMT TAPE & REEL DRAWING NUMBER: M22-655XX42R	SHT 4 OF 4
--------------------------------------------	-----------------------------------------------------------------------------------------------------------------------------------------------------------------------------------------------------------------------------------------------------------------------------	----------------------------------------------------------------------------------------------------------------	----------------------------------------------------------------------------	---------------------------------------------------------------------------------------------------------	------------------