

Differences between Selected Cinterion[®] Modules

Hardware Migration Guide

Version: 11
DocID: BGSx_EHSx_ELSx_EMS31_ENS22_EXS82_migration_v11

Document Name: **Differences between Selected Cinterion® Modules**

Version: **11**

Date: **August 21, 2019**

DocId: **BGSx_EHSx_ELSx_EMS31_ENS22_EXS82_migration_v11**

Status: **Confidential / Preliminary**

Selected modules: **See Section 1.1**

GENERAL NOTE

THE USE OF THE PRODUCT INCLUDING THE SOFTWARE AND DOCUMENTATION (THE "PRODUCT") IS SUBJECT TO THE RELEASE NOTE PROVIDED TOGETHER WITH PRODUCT. IN ANY EVENT THE PROVISIONS OF THE RELEASE NOTE SHALL PREVAIL. THIS DOCUMENT CONTAINS INFORMATION ON GEMALTO M2M PRODUCTS. THE SPECIFICATIONS IN THIS DOCUMENT ARE SUBJECT TO CHANGE AT GEMALTO M2M'S DISCRETION. GEMALTO M2M GMBH GRANTS A NON-EXCLUSIVE RIGHT TO USE THE PRODUCT. THE RECIPIENT SHALL NOT TRANSFER, COPY, MODIFY, TRANSLATE, REVERSE ENGINEER, CREATE DERIVATIVE WORKS; DISASSEMBLE OR DECOMPILE THE PRODUCT OR OTHERWISE USE THE PRODUCT EXCEPT AS SPECIFICALLY AUTHORIZED. THE PRODUCT AND THIS DOCUMENT ARE PROVIDED ON AN "AS IS" BASIS ONLY AND MAY CONTAIN DEFICIENCIES OR INADEQUACIES. TO THE MAXIMUM EXTENT PERMITTED BY APPLICABLE LAW, GEMALTO M2M GMBH DISCLAIMS ALL WARRANTIES AND LIABILITIES. THE RECIPIENT UNDERTAKES FOR AN UNLIMITED PERIOD OF TIME TO OBSERVE SECRECY REGARDING ANY INFORMATION AND DATA PROVIDED TO HIM IN THE CONTEXT OF THE DELIVERY OF THE PRODUCT. THIS GENERAL NOTE SHALL BE GOVERNED AND CONSTRUED ACCORDING TO GERMAN LAW.

Copyright

Transmittal, reproduction, dissemination and/or editing of this document as well as utilization of its contents and communication thereof to others without express authorization are prohibited. Offenders will be held liable for payment of damages. All rights created by patent grant or registration of a utility model or design patent are reserved.

Copyright © 2019, Gemalto M2M GmbH, a Gemalto Company

Trademark Notice

Gemalto, the Gemalto logo, are trademarks and service marks of Gemalto and are registered in certain countries. Microsoft and Windows are either registered trademarks or trademarks of Microsoft Corporation in the United States and/or other countries. All other registered trademarks or trademarks mentioned in this document are property of their respective owners.

Contents

0	Document History	6
1	Introduction	9
1.1	Supported Products	9
1.2	Related Documents.....	10
1.3	Type Approval.....	10
2	Software Related Differences.....	10
3	Hardware Related Differences	10
3.1	Feature Overview.....	11
3.2	General Properties.....	13
3.2.1	Frequency Bands	13
3.2.2	Dimensions.....	14
3.2.3	Operating Temperature	14
3.2.4	Power Supply Ratings	15
3.3	Application Interface.....	18
3.3.1	ON (and AUTO_ON) Signal	18
3.3.2	Common Ignition Circuit for ON (and AUTO_ON) Signal.....	19
3.3.3	EMERG_RST	21
3.3.4	Power Supply BATT+	22
3.3.5	Voltage Domain VDIG, V180, V285/VCORE	25
3.3.6	Power Indication Circuit.....	26
3.3.7	RTC Backup VDDL	28
3.3.8	SIM Interface	28
3.3.9	Second SIM interface	30
3.3.10	USB Interface	30
3.3.11	ASC0 Interface	31
3.3.12	ASC1 Interface	33
3.3.13	ASC2 Interface	34
3.3.14	I ² C Interface	35
3.3.15	SPI Interface	37
3.3.16	HSIC Interface.....	37
3.3.17	Audio Interface	38
3.3.18	Digital Audio Interface	38
3.3.19	Analogue Audio Interface	40
3.3.20	GPIO Interface	41
3.3.21	ADC1.....	45
3.3.22	Fast Shutdown	46
3.4	Antenna Interface.....	47
3.4.1	RF Antenna	47
3.4.2	GNSS Antenna.....	48
3.4.3	Rx Diversity Antenna	49
4	Common Footprint Design	50
4.1	Combined Land Pattern	57
4.2	Test Points.....	58

Tables

Table 1: Feature overview	11
Table 2: Frequency bands.....	13
Table 3: Dimensions.....	14
Table 4: Board / battery temperatures [°C].....	14
Table 5: Power supply ratings	15
Table 6: ON signal characteristics.....	18
Table 7: Common Ignition circuit component placement	20
Table 8: EMERG_RST characteristics	21
Table 9: BATT+ power supply pads and interference suppression.....	22
Table 10: Interference suppression circuit components.....	24
Table 11: Voltage domain configuration	25
Table 12: Power indication circuit components.....	26
Table 13: Power indication circuit components.....	28
Table 14: SIM interface – enhanced ESD protection	28
Table 15: USB interface	30
Table 16: ASC0 transfer rates.....	31
Table 17: ASC0 start-up/reset signal states	31
Table 18: ASC1 transfer rates.....	33
Table 19: ASC1 start-up/reset signal states	33
Table 20: ASC2 transfer rates.....	34
Table 21: ASC2 start-up/reset signal states	34
Table 22: I ² C pull-up values (internal or external).....	35
Table 23: I ² C start-up/reset signal states.....	36
Table 24: SPI interface.....	37
Table 25: Audio interfaces overview.....	38
Table 26: PCM characteristics.....	38
Table 27: DAI start-up/reset signal states.....	39
Table 28: Analogue audio interface.....	40
Table 29: GPIO lines	41
Table 30: GPIO start-up/reset signal states.....	43
Table 31: ADC1 characteristics	45
Table 32: FST_SHDN characteristics.....	46
Table 33: ESD protection on external application.....	48
Table 34: GNSS antenna	48
Table 35: Rx diversity antenna	49
Table 36: Pad assignments for BGSx, EHSx, ELSx, EMS31, Cinterion® ENS22, and EXS82.....	53
Table 37: Mandatory and optional test points for SMT applications.....	58

Figures

Figure 1: Common ignition circuit	19
Figure 2: BATT+ and external interference suppression circuit	23
Figure 3: Power indication circuit.....	27
Figure 4: Power indication circuit for BGS12 (V280) and Cinterion® ENS22 (V300) only.....	27
Figure 5: SIM interface - enhanced ESD protection	29
Figure 6: I2C pull-up resistors on external application	36
Figure 7: Possible BGS5, EHSx, ELSx, and EMS31 ESD protection circuits - T or PI pad...	47
Figure 8: Possible designated ESD protection circuit - T or PI pad	47
Figure 9: Common footprint for BGSx, EHSx, ELSx, EMS31, Cinterion® ENS22, and EXS82 (bottom view).....	52
Figure 10: Combined land pattern (top view).....	57

0 Document History

Preceding document: "Differences between Selected Cinterion® Modules", Version 10

New document: "Differences between Selected Cinterion® Modules", Version 11

Chapter	What is new
Throughout document	Added product Cinterion® ENS22-E Rel.1.1. Removed support for digital audio interface from BGS12. Revised temperature ranges for EXS82-W.
3.2.2	Added approximate weight for EXS82-W.
3.2.4	Added some power supply ratings for EXS82-W.
3.3.3	Added low pulse length (>800ms) for EMERG_RST line for EXS82-W.

Preceding document: "Differences between Selected Cinterion® Modules", Version 09

New document: "Differences between Selected Cinterion® Modules", Version 10

Chapter	What is new
Throughout document	Revised descriptions for BGS12. EXS82-W: Removed support for VDDL, and support for LTE Cat. M1 Bd71, as well as LTE Cat. NB1/NB2 Bd17 and Bd71 in Table 1.

Preceding document: "Differences between Selected Cinterion® Modules", Version 08

New document: "Differences between Selected Cinterion® Modules", Version 09

Chapter	What is new
Throughout document	Added products EXS82-W and BGS12.

Preceding document: "Differences between BGSx, EHSx, ELSx, EMS31, and Cinterion® ENS22", Version 07

New document: "Differences between Selected Cinterion® Modules", Version 08

Chapter	What is new
3.2.2	Added approximate weight for Cinterion® ENS22.
3.3.3	Added Rin for Cinterion® ENS22's EMERG_RST line.
3.3.5	Revised settings for EMS31 in Table 11.
3.3.8	Revised pull-up resistor setting for EMS31 in Table 14.
3.3.11, 3.3.12	Added startup/reset signal states for Cinterion® ENS22's ASC0/ASC1 lines. Revised footnote for EMS31 for RTS0 wake-up in Table 16.
3.3.13	Added R1min/R2min values for Cinterion® ENS22's I2C internal pull-ups. Added startup/reset signal states for Cinterion® ENS22's I2CDAT/I2CCLK lines.

Chapter	What is new
3.3.18	Revised DAI startup/reset states for ELS31 in Table 27.
3.3.20	Added startup/reset signal states for Cinterion® ENS22's GPIO lines.
4	Revised BGS1 signal assignments for pads 44, 45, 46. Revised ENS22 signal assignments for pad 40.

Preceding document: "Differences between BGSx, EHSx, ELSx and EMSx", Version 06

New document: "Differences between BGSx, EHSx, ELSx, EMS31, and Cinterion® ENS22", Version 07

Chapter	What is new
Throughout document	Added Cinterion ENS22-C and Cinterion® ENS22-E.
3.3.3	Added note for BGS5 (Rin).

Preceding document: "Differences between BGSx, EHSx, ELSx and EMSx", Version 05

New document: "Differences between BGSx, EHSx, ELSx and EMSx", Version 06

Chapter	What is new
Throughout document	Added ELS81-E and ELS81-US. Revised content for ELS61, EMS31.

Preceding document: "Differences between BGS2, BGS5, EHSx and ELSx", Version 04

New document: "Differences between BGSx, EHSx, ELSx and EMSx", Version 05

Chapter	What is new
Throughout document	Added ELS61-USA, ELS61-E Rel.2 and ELS31-VA and adapted content accordingly. Added BGS1 and adapted content accordingly. Removed references to ELS51/EMS51.
4.2	New section Test Points

Preceding document: "Differences between BGS2, BGS5, EHSx and ELSx", Version 03

New document: "Differences between BGS2, BGS5, EHSx and ELSx", Version 04

Chapter	What is new
Throughout document	Added further products, and adapted content accordingly.

Preceding document: "Differences between BGS2, BGS5, EHSx and ELSx", Version 02

New document: "Differences between BGS2, BGS5, EHSx and ELSx", Version 03

Chapter	What is new
Throughout document	Added further product variants, and adapted content accordingly.
3.2.4	Revised power supply ratings for ELSx, and shifted complete section.
3.3.2	Added notes for common ignition circuit and EHSx.
3.3.3	Added note for EMERG_RST with ELS31 and ELS51.
3.3.4	Revised section to include blocking filter for ELS61.
3.3.20	Revised valid range for ADC1 input.
3.3.21	Added fast shutdown timings and AT^SMSO behavior.
3.4.3	New section Rx Diversity Antenna.
4	Revised some pad assignments for BGS2 in Table 34.

Preceding document: "Differences between BGS2, BGS5, EHSx and ELSx", Version 01

New document: "Differences between BGS2, BGS5, EHSx and ELSx", Version 02

Chapter	What is new
3.1	Added LTE band 28 (700MHz) support for ELS61-E.
3.3.1	Revised ON: V_{IHmax} value for ELS61 in Table 6.
3.2.4	Revised power supply ratings for ELS61 in Table 5.
4	Revised SPI pad assignment for ELS31/ELS51: Pad 106 → SPI_MOSI, pad 249 → SPI_MISO

New document: "Differences between BGS2, BGS5, EHSx and ELSx", Version 01

Chapter	What is new
---	Initial document setup.

1 Introduction

This document¹ compares the Gemalto M2M Cinterion® modules BGS1, BGS12, BGS2, BGS5, EHS5, EHS6, EHS8, ELS61, ELS81, ELS31, EMS31, Cinterion® ENS22, as well as EXS82. It lists hardware related differences between these products.

The aim of the document is to provide guidance on how to migrate between any of the above products. Chapter 4 gives advice on designing one common hardware platform for smooth transition between all described products, including possible test points.

1.1 Supported Products

The following table shows the supported products including their module variants and release versions. Where necessary a note is made to differentiate between the various product variants and releases.

Product	Variant	As of Release (Revision)
BGS1	BGS1	Rel.2 (v02.000)
BGS12	BGS12	Rel.1 (TBD.)
BGS2	BGS2-E	Rel.2 (v02.000)
	BGS2-W	Rel.2 (v02.000)
BGS5	BGS5	Rel.1 (v01.100)
EHS5	EHS5-E	Rel.3 (v03.001)
	EHS5-US	Rel.3 (v03.001)
EHS6	EHS6	Rel.3 (v03.001)
	EHS6-A	Rel.3 (v03.001)
EHS8	EHS8	Rel.3 (v03.001)
ELS61	ELS61-E	Rel.1 (v01.000)
	ELS61-E R2	Rel.2 (v02.000)
	ELS61-E2	Rel.1 (v01.000)
	ELS61-US	Rel.1 (v01.000)
	ELS61-USA	Rel.2 (v02.000)
	ELS61-AUS	Rel.1 (v01.000)
ELS81	ELS81-E	Rel.1 (v04.000)
	ELS81-US	Rel.1 (v04.000)
ELS31	ELS31-V	Rel.2 (v4.3.3.0)
	ELS31-VA	Rel.2 (v4.3.4.0)
	ELS31-J	Rel.2 (v4.3.2.1)
EMS31	EMS31-V	Rel.1 (v5.0.1.0)
	EMS31-US	Rel.1 (v5.1.1.0)
	EMS31-X	Rel.1 (v03.000)
Cinterion® ENS22	Cinterion ENS22-C	Rel.1 (v01.000)
	Cinterion® ENS22-E	Rel.1 (v01.000)
	Cinterion® ENS22-E	Rel.1.1 (v02.000)
EXS82	EXS82-W	Rel. 1

¹ The document is effective only if listed in the appropriate Release Notes as part of the technical documentation delivered with your Gemalto M2M product.

1.2 Related Documents

- [1] Hardware Interface Description for the appropriate Cinterion® product
- [2] AT Command Set for the appropriate Cinterion® product
- [3] Application Note 48: SMT Module Integration for the appropriate Cinterion® product

1.3 Type Approval

BGS1, BGS12, BGS2, BGS5, EHSx, ELSx, EMS31, Cinterion® ENS22 and EXS82 comply with the same standards and directives – except for

- Standards of North American type approval that are not applicable to products not supporting PTCRB bands
- Standards of European type approval that are not applicable to products not supporting GCF bands

Because EHSx and ELS61/81 feature UMTS/HSPA (3G) functionality they also comply with standards for WCDMA. Because ELS61/81 (additionally) and EMS31 feature LTE (4G) functionality they also comply with standards for LTE, and because Cinterion® ENS22 features NB-IoT functionality it also complies with standards for LTE NB-IoT. EXS82 complies with the standards for LTE 4G, LTE NB-IoT and 2G. For more regulatory and type approval information see [1].

2 Software Related Differences

For a complete overview of all AT command differences between BGS1, BGS12, BGS2, EHSx, ELSx, EMS31, Cinterion® ENS22, and EXS82 please refer to the respective AT Command Specifications (see [2]).

3 Hardware Related Differences

The focus of this chapter is on hardware differences between BGS1, BGS12, BGS2, BGS5, EHS5, EHS6, EHS8, ELS31, ELS61, ELS81, EMS31, Cinterion® ENS22 and EXS82.

Please note that for the current EMS31 Rel.1 the following features mentioned in this document are not yet implemented: GP(I)O, I²C, PWM, SPI, ADC, 2nd SIM/MIM and impulse counter.

Also note that for the current EXS82 Rel.1 the following features mentioned in this document are not yet implemented: I²C, PWM, SPI

3.1 Feature Overview

Table 1: Feature overview

Feature/Property	BGS1	BGS12	BGS2	BGS5	EHS5	EHS6, EHS8	ELS61, ELS81	ELS31	EMS31	Cinterion® ENS22	EXS82
General Properties											
Power supply ratings	For details see Section 3.2.4. Normal operation: -30°C to +85°C Extended operation: -40°C to +90°C (+85°C for Cinterion® EXS82)										
Operating temperature (board temperature)											
Dimensions	27.6 x 18.8 x 2.7mm	27.6 x 18.8 x 2.7mm	27.6 x 18.8 x 2.7mm	27.6 x 18.8 x 2.6mm	27.6 x 18.8 x 2.2mm	27.6 x 25.4 x 2.2mm	27.6 x 25.4 x 2.2mm	27.6 x 18.8 x 2.1mm	27.6 x 18.8 x 2.05mm	27.6 x 18.8 x 2.5mm	27.6 x 18.8 x 2.3mm
3GPP technology	2G	2G	2G	2G	2G / 3G	2G / 3G	2G / 3G / 4G (Cat 1)	4G (Cat 1)	4G (Cat M1)	4G (Cat NB1)	2G / 4G (Cat M1+Cat NB1/2)
Frequency bands GSM	Dual band : GSM 900/1800MHz	Quad band 850/900/1800/1900	BGS2-W: Quad band 850/900/1800/1900 BGS2-E: Dual band 900/1800	Quad band 850/900/1800/1900	EHS5-US: Dual band 850/1900 EHS5-E: Dual band 900/1800	Quad band 850/900/1800/1900	ELS61-E/-E R2/-E2/ ELS81-E: Dual band: 900/1800	Not supported	Not supported	Not supported	Quad band 850/900/1800/1900
Frequency bands UMTS	Not supported	Not supported	Not supported	Not supported	EHS5-US: Dual band 850/1900 EHS5-E: Dual band 900/2100	Five band 800/850/900/1900/2100	ELS61-E R2, ELS81-E: Dual Band 900/2100 ELS61-US(A) / ELS81-US: Tri band 850/AWS/1900 ELS61-AUS: Tri band 850/900/2100	Not supported	Not supported	Not supported	Not supported
Frequency bands LTE	Not supported	Not supported	Not supported	Not supported	Not supported	Not supported	ELS61-US(A): Quad band: 700/850/AWS/1900 (Bd2, Bd4, Bd5, Bd12) ELS61-E/-E R2: Quad band 800/900/1800/2100 (Bd1, Bd3, Bd8, Bd20) ELS61-E2/ELS81-E: Penta band 700/800/900/1800/ 2100 (Bd1, Bd3, Bd8, Bd20, Bd28) ELS61-AUS: Quad band 700/850/900/1800 (Bd3, Bd5, Bd8, Bd28)	ELS31-V, ELS31-VA: Dual Band: 700/1700 (Bd4, Bd13) ELS31-J: Tri Band: 800/850/2100 (Bd1, Bd18, Bd19)	EMS31-V: Dual Band: Half-Duplex-FDD 700/AWS (Bd4, Bd13) EMS31-US: Tri Band: Half-Duplex-FDD 700/AWS/1900 (Bd2, Bd4, Bd12)	Penta band (LTE Cat NB1): 1800/850/900/800/750 (Bd3, Bd5, Bd8, Bd20, Bd28)	LTE Cat M1 Bands: 700 (Bd12, Bd13, Bd14, Bd28, Bd85), 800 (Bd18, Bd19, Bd20, Bd26, Bd27), 850 (Bd5), 900 (Bd8), 1700 (Bd66), AWS (Bd4), 1800 (Bd3), 1900 (Bd2, Bd25), 2100 (Bd1) LTE Cat NB1/2 Bands: 700 (Bd12, Bd13, Bd28, Bd85), 800 (Bd18, Bd19, Bd20, Bd26), 850 (Bd5), 900 (Bd8), 1700 (Bd66), AWS (Bd4), 1800 (Bd3), 1900 (Bd2, Bd25), 2100 (Bd1)
Output Power GSM 850/900 GSM 1800/1900 UMTS LTE NB-IoT	+33dBm +30dBm -- -- --	+33dBm +30dBm -- -- --	+33dBm +30dBm -- -- --	+33dBm +30dBm -- -- --	+33dBm +30dBm +24dBm -- --	+33dBm +30dBm +24dBm -- --	+33dBm +30dBm +23.5dBm +23dBm --	-- -- -- +23dBm --	-- -- -- +23dBm --	-- -- -- +23dBm --	+33dBm +30dBm -- +20dBm +20dBm
Antenna	Single 50Ω	Single 50Ω	Single 50Ω	Single 50Ω	Single 50Ω	Single 50Ω	Dual 50Ω, Main, Rx Diversity	Dual 50Ω, Main, Rx Diversity	Single 50Ω	Single 50Ω	Single 50Ω Main (plus GNSS antenna)
Interface Properties											
Module interface	For pad assignment see Chapter 4.										
Serial interfaces											
ASC0	8 wire, Level 1.8V Baudrate: 1200 to 230,400bps Autobauding: 1,200bps to 230,400bps Flow control: RTS0/CTS0	8 wire, Level: 2.8V Baudrate: 4,800 to 230,400bps Autobauding: 4,800 to 230,400bps Flow control: RTS0/CTS0	8 wire, Level: 1.8V Baudrate: 300 to 230,400bps Autobauding: 1,200 to 230,400bps Flow control: RTS0/CTS0 and XON/XOFF	8 wire, Level: 1.8V Baudrate: 1,200 to 921,600bps Autobauding: 1,200 to 230,400bps Flow control: RTS0/CTS0	8 wire, Level: 1.8V Baudrate: 1,200 to 921,600bps Autobauding: 1,200 to 230,400bps Flow control: RTS0/CTS0	8 wire, Level: 1.8V Baudrate: 1,200 to 921,600bps Autobauding: 1,200 to 230,400bps Flow control: RTS0/CTS0	8 wire, Level: 1.8V Baudrate: 1,200 to 3Mbit Autobauding: 1,200 to 230,400bps Flow control: RTS0/CTS0	8 wire, Level: 1.8V Baudrate: 4,800 to 921,600bps default: 115,200bps Flow control: RTS0/CTS0	8 wire, Level: 1.8V Baudrate: 4,800 to 3,686,400 bps default: 115,200bps Flow control: RTS0/CTS0	8 wire, Level: 3.0V Baudrate: 1,200 to 921,600bps default: 115,200bps Flow control: RTS0/CTS0	8 wire, Level: 1.8V Baudrate: 300 to 921,600bps default: 115,200bps Flow control: RTS0/CTS0
ASC1	4 wire, Level 1.8V Baudrate 1200 to 230,400bps Autobauding: 1,200bps to 230,400bps Flow control: RTS1/CTS1	2 wire, Level: 2.8V Baudrate: fixed 921,600bps Flow control: Not supported For firmware upgrading and tracing	4 wire, Level: 1.8V Baudrate: 300 to 230,000bps Flow control: RTS1/CTS1 and XON/XOFF	4 wire, Level: 1.8V Baudrate: 1,200 to 921,600bps Autobauding: 1,200 to 230,400bps Flow control: RTS1/CTS1	4 wire, Level: 1.8V Baudrate: 1,200 to 921,600bps Autobauding: 1,200 to 230,400bps Flow control: RTS1/CTS1	4 wire, Level: 1.8V Baudrate: 1,200 to 921,600bps Autobauding: 1,200 to 230,400bps Flow control: RTS1/CTS1	4 wire, Level: 1.8V Baudrate: 1,200 to 921,600bps Autobauding: 1,200 to 230,400bps Flow control: RTS1/CTS1	4 wire, Level: 1.8V Baudrate: 4,800 to 921,600bps Flow control: RTS1/CTS1	4 wire, Level: 1.8V Baudrate: 4,800 to 3,686,400 bps Flow control: RTS1/CTS1	4 wire, Level: 3.0V Baudrate: 1,200 to 921,600bps Flow control: RTS1/CTS1	4 wire, Level: 1.8V Baudrate: 300 to 921,600bps Flow control: RTS1/CTS1
ASC2	Not supported	4 wire, Level: 2.8V Baudrate: 4,800 to 230,400bps Autobauding: Not supported Flow control: RTS2/CTS2	Not supported	Not supported	Not supported	Not supported	Not supported	Not supported	Not supported	Not supported	Not supported

Feature/Property	BGS1	BGS12	BGS2	BGS5	EHS5	EHS6, EHS8	ELS61, ELS81	ELS31	EMS31	Cinterion® ENS22	EXS82
USB interface	Not supported	Not supported	Not supported	USB 2.0 High Speed (480Mbit/s) device interface, full speed compliant	USB 2.0 High Speed (480Mbit/s) device interface, full speed compliant	USB 2.0 High Speed (480Mbit/s) device interface, full speed compliant	USB 2.0 High Speed (480Mbit/s) device interface, full speed compliant	USB 2.0 High Speed (480Mbit/s) device interface, full speed compliant	Not supported	Not supported	USB 2.0 High Speed (480Mbit/s) device interface, full speed compliant For debugging purposes only
UICC interface	SIM/USIM: 3V, 1.8V	SIM/USIM: 3V, 1.8V	SIM/USIM: 3V, 1.8V.	SIM/USIM: 3V, 1.8V.	SIM/USIM: 3V, 1.8V.	SIM/USIM: 3V, 1.8V.	SIM/USIM: 3V, 1.8V.	SIM/USIM: 3V, 1.8V.	SIM/USIM: 3V, 1.8V.	SIM/USIM: 3V, 1.8V. Cinterion® ENS22-E Rel.1.1: Not supported with eSIM option	SIM/USIM 1.8V
Audio interfaces											
Analog audio	One balanced audio interface	One balanced audio interface	One balanced audio interface	Not supported (Hardware prepared for future use)	Not supported	Not supported EHS6-A: One balanced audio interface	Not supported	Not supported	Not supported	Not supported	Not supported
Digital audio	Not supported	Not supported	Supported See Section 3.3.18	Supported See Section 3.3.18	Supported See Section 3.3.18	Supported See Section 3.3.18	Not supported ELS61-E R2, ELS61-USA: Supported See Section 3.3.18	Not supported (Hardware prepared for future use) ELS31-VA: supported See Section 3.3.18	Not supported	Not supported	Not supported
Other interfaces											
RTC backup	Yes VDDL 1.8V...4.2V	Yes VDDL 2.6V...3.3V	Yes VDDL 1V...2.4V	Yes VDDL 1V...1.9V	Yes VDDL 1V...1.9V	Yes VDDL 1V...1.9V	Yes VDDL 1V...1.9V	Not supported	Not supported	Not supported	Not supported
GPIO interface	6 GPIO: 5 GPIO shared (I2C, SIM_SWITCH, Status LED, PWM, Jamming Indicator) 1 GPIO not shared	6 GPIO: 4 GPIO shared (I ² C, LED, Jamming Indicator) 2 GPIO not shared	6 GPIO: 5 GPIO shared (I ² C, LED, PWM, Jamming Indicator) 1 GPIO not shared	17 GPIO: 17 GPIO shared (ASC0, ASC1, DAI, SPI, LED, PWM, FST_SHDN, Counter)	17 GPIO: 17 GPIO shared (ASC0, ASC1, DAI, SPI, LED, PWM, FST_SHDN, Counter)	22 GPIO: 13 GPIO shared (ASC0, ASC1, DAI, SPI, LED, PWM, HSIC, FST_SHDN, Counter) 5 GPIO not shared	22 GPIO: 13 GPIO shared (ASC0, ASC1, SPI, LED, PWM, Counter, FST_SHDN) 9 GPIO not shared	20 GPIO: 17 GPIO + 3 GPO shared (ASC0, ASC1, SPI, LED, Counter, FST_SHDN) 3 GPIO not shared	20 GPIO shared with Serial Interface SPI	13 GPIO: 10 GPIO shared (I2C, ASC0, ASC1, SPI) 3 GPIO not shared Cinterion® ENS22-E Rel.1.1: 8 GPIO shared (I2C, ASC0, ASC1, SPI) 5 GPIO not shared	Not supported with Rel.1, but hardware prepared
SDIO	Not supported	Not supported	Not supported	Not supported	Not supported	Not supported	Not supported	Not supported (only as module wakeup line)	Not supported	Not supported	Not supported
ADC	10bit; 0V...1.2V	Not supported	10bit; 0...1.2V	10bit; 0...1.14V	10bit; 0...1.2V	10bit; 0...1.2V	10bit; 0...1.2V	10bit; 0...2.0V	10bit; 0...1.9V	Not supported	15bit; 0.1V... 1.7V
Ignition signal	ON Rising edge (high pulse)	ON High pulse >2s	ON: Rising edge (high pulse)	ON: Rising edge (high pulse)	ON: High pulse ~60µs AUTO_ON: Low level	ON: High pulse ~60µs AUTO_ON: Low level	ON: Rising edge (high pulse)	ON: Rising edge (high pulse)	ON: Rising edge (high pulse)	ON: Rising edge (high pulse)	ON: Rising edge
Reset Signal	Supported	Not supported	Supported	Supported	Supported	Supported	Supported	Supported	Supported	Supported	Supported
I ² C Interface	I ² C at GPIO9 / 10	I2C at GPIO9 / 10	I ² C at GPIO9 / 10	I ² C at dedicated lines	I ² C at dedicated lines	I ² C at dedicated lines	I ² C at dedicated lines	I ² C at dedicated lines	Supported	Supported Cinterion® ENS22-E Rel.1.1: Not supported	Not supported with Rel.1, but hardware prepared
SPI Interface	Not supported	Not supported	Not supported	SPI shared with GPIOs	SPI shared with GPIOs	SPI shared with GPIOs	SPI shared with GPIOs	SPI at dedicated lines and shared with GPIOs	Supported	Supported Cinterion® ENS22-E Rel.1.1: Not supported	Not supported with Rel.1, but hardware prepared
HSIC Interface	Not supported	Not supported	Not supported	Not supported	Not supported	Supported	Not supported (Hardware prepared for future use)	Not supported	Not supported	Not supported	Not supported
Fast shutdown signal	Dedicated line	Dedicated line	Dedicated line	Shared with GPIO	Shared with GPIO	Shared with GPIO	Shared with GPIO	Shared with GPIO	Shared with GPIO	Not supported	Dedicated line
GNSS	Not supported	Not supported	Not supported	Not supported	Not supported	EHS6: Not supported EHS8: GPS supported	Not supported	Not supported	Not supported	Not supported	GPS, GLONASS, BeiDou, Galileo
UMTS/HSPA	Not supported	Not supported	Not supported	Not supported	Supported	Supported	ELS61-US(A)/ELS81-E/US: Supported ELS61-E: Not supported ELS61-E R2: Supported ELS61-E2: Not supported ELS61-AUS: Supported	Not supported	Not supported	Not supported	Not supported
EGPRS	Not supported	Not supported	Not supported	Not supported	Multislot class 12	Multislot class 12	ELS61-US: Not supported ELS61-E/-E R2/ELS81-E: Supported ELS61-E2: Supported ELS61-AUS: Not supported	Not supported	Not supported	Not supported	Multislot class 10
GPRS	Multislot class 12	Multislot class 12	Multislot class 10	Multislot class 12	Multislot class 12	Multislot class 12	ELS61-US: Not supported ELS61-E/-E R2/ELS81-E: Supported ELS61-E2: Supported ELS61-AUS: Not supported	Not supported	Not supported	Not supported	Multislot class 10
LTE Cat. NB1	Not supported	Not supported	Not supported	Not supported	Not supported	Not supported	Not supported	Not supported	Not supported	Supported	Supported
LTE Cat. NB2	Not supported	Not supported	Not supported	Not supported	Not supported	Not supported	Not supported	Not supported	Not supported	Not supported	Supported
Software	For software related differences please refer to [2].										

3.2 General Properties

3.2.1 Frequency Bands

Table 2: Frequency bands

Module	Frequency bands
BGS1	GSM 900/1800
BGS12	GSM 850/900/1800/1900
BGS2	BGS2-W: GSM 850/900/1800/1900 BGS2-E: GSM 900/1800
BGS5	GSM 850/900/1800/1900
EHS5	EHS5-US: GSM 850/1900, UMTS 850/1900 EHS5-E: GSM 900/1800, UMTS 900/2100
EHS6, EHS8	GSM 850/900/1800/1900 UMTS 800/850/900/1900/2100
ELS61	ELS61-US, ELS61-USA: UMTS 850/AWS/1900, LTE 700/850/AWS/1900 ELS61-E: GSM 900/1800, LTE 800/900/1800/2100 ELS61-E R2: GSM 900/1800, UMTS 900/2100, LTE 800/900/1800/2100 ELS61-E2: GSM 900/1800, LTE 700/800/900/1800/2100 ELS61-AUS: UMTS 850/900/2100, LTE 700/850/900/1800
ELS81	ELS81-E: GSM/GPRS/EDGE: 900/1800, UMTS: 900/2100, LTE: 700/800/900/1800/2100 ELS81-US: UMTS: 850/AWS/1900, LTE: 700/850/AWS/1900
ELS31	ELS31-V: LTE: 700/1700 ELS31-VA: LTE: 700/1700 ELS31-J: LTE: 800/850/2100
EMS31	EMS31-V: LTE: 700/AWS, Half-Duplex-FDD EMS31-US: LTE: 700/AWS/1900, Half-Duplex-FDD
Cinterion® ENS22	Cinterion® ENS22: LTE Cat NB1 (NB-IoT): 700/800/850/900/1800
EXS82	EXS82-W: GSM 850/900/1800/1900, LTE (Cat M1, Cat NB1/2): 600, 700, 800, 850, 900, 1700, AWS, 1800,1900, 2100

Reference:

“Hardware Interface Description”: Section “Key Features at a Glance”

3.2.2 Dimensions

Table 3: Dimensions

Module	Length x Width [mm]	Hight [mm]	Weight	Pad count (LGA number)
BGS1	27.6 x 18.8	2.7	~2.3g	106
BGS12	27.6 x 18.8	2.7	~2.2g	114
BGS2	27.6 x 18.8	2.7	~3g	106
BGS5	27.6 x 18.8	2.6	~3g	114
EHS5	27.6 x 18.8	2.2	~3g	106
EHS6, EHS8	27.6 x 25.4	2.2	~3.5g	120
ELS61	27.6 x 25.4	2.2	~3.5g	120
ELS81	27.6 x 25.4	2.2	~3.5g	120
ELS31	27.6 x 18.8	2.1	~3g	114
EMS31	27.6 x 18.8	2.17	~2.2g	114
Cinterion® ENS22	27.6 x 18.8	2.5	~2.5g	106
EXS82	27.6 x 18.8	2.3	~2.5g	114

Reference:

- “Hardware Interface Description”: Section “Mechanics” and “Pad Assignment”

3.2.3 Operating Temperature

Table 4: Board / battery temperatures [°C]

Parameter	BGS1	BGS12	BGS2	BGS5	EHS5, EHS6, EHS8	ELS61, ELS81	ELS31	EMS31	Cinterion® ENS22	EXS82
Operating temperature	-30°C ... +85°C (-20 for BGS12)									
Extended temperature	-40°C ... +90°C (-40°C ... +85°C for Cinterion® ENS22)									
Automatic shutdown at board temperature	<-40°C and >+90°C (<-40°C and >+85°C for Cinterion® ENS22, as well as >+95°C for BGS12)									

Reference:

- “Hardware Interface Description”: Section “Operating Temperatures”

3.2.4 Power Supply Ratings

Power supply ratings differ between the modules. Table 5 lists some of these ratings, to highlight differences among various modules.

Please refer to the respective module's Hardware Interface Description for further power supply ratings specified with regard to additional features available with these products (i.e., LTE, UMTS, USB, GNSS).

Reference:

- "Hardware Interface Description": Section "Power Supply Ratings"

Table 5: Power supply ratings²

Parameter	Description	Conditions	BGS1	BGS12	BGS2	BGS5	EHS5	EHS6, EHS8 ³	ELS61, ELS81 ^{4,5}	ELS31	EMS31	Cinterion® ENS22	EXS82	Unit
BATT+	Supply voltage	Voltage including drop, ripple and spikes.	3.3...4.5	3.4...4.2	3.3...4.5	3.3...4.5	3.3...4.5	3.3...4.5	3.0...4.5	3.3...4.5	3.2...5.5	2.8...4.2	3.0...4.5 2.5...4.8 (w/o GSM)	V
	Max voltage drop during transmit burst	Normal condition, max RF output power	400 (2G)	400 (2G)	400 (2G)	400 (2G)	400 (2G)	400 (2G)	400 (2G)	N/A	N/A	400 (LTE Cat. NB1)	400 (2G)	mV
	Voltage ripple	Normal condition, power control level for Pout max @ f<250kHz @ f>250kHz	-- --	TBD. TBD.	85 25	190 30	80 20	80 20	120 90	110 30	110 30	120 90	TBD. TBD.	mVpp
I _{VDDL} P	OFF state supply current	RTC backup @ BATT+ = 0V	47	170	8	2.4	1.7	1.6	1.8 0.1 for ELS81	N/A	N/A	N/A	N/A	µA

² GSM850 and GSM1900 bands are applicable for the quad band module variants only.

³ Only the appropriate highest rating out of all EHS6/EHS8 product variants is mentioned. For detailed values refer to [1].

⁴ With ELS61, power supply ratings depend to quite a degree on the current supply voltage, and may thus vary up to 30% across the voltage range. Ratings given here were measured @3.8V. With Cinterion® ENS22, ratings given here were measured @3.6V.

⁵ Only the appropriate highest rating out of all ELS61/ELS81 product variants is mentioned. For detailed values refer to [1].

Parameter	Description	Conditions	BGS1	BGS12	BGS2	BGS5	EHS5	EHS6, EHS8 ³	ELS61, ELS81 ^{4,5}	ELS31	EMS31	Cinterion® ENS22	EXS82	Unit	
I _{BATT+}	OFF state supply current	Power Down mode	225	38	45	42	65	125	90 75 for ELS81	<15	<2	<5		µA	
	SLEEP current ⁶ GSM/GPRS UMTS LTE	DRX=2 & 9 ⁷ DRX=6 & 9 ⁷ RRC=1.28s & 2.58s ⁷	2.3, 2.0 (GSM) 2.1, 1.8 (GPRS)	1.6, 0.9 -- --	2.2, 1.2 -- --	1.5, 1.0 -- --	2.2, 1.6 2.5, 1.8 --	2.2, 1.7 2.5, 1.8 --	3.0, 2.4 3.0, 2.3 3.0, 2.6	-- -- --	-- -- --	-- -- --	TBD. -- TBD.	mA	
	IDLE current ⁶ GSM UMTS LTE LTE	DRX=2 ⁷ DRX=6 ⁷ --- RRC=1.28s & 2.58s ⁷	13.5 -- -- --	12.6 -- -- --	8.6 -- -- --	21 -- -- --	17 15 -- --	20 20 -- --	12.3 13 ⁸ 17 ⁸ --	-- -- -- 5.5, 4.0	-- -- -- 2.0, 1.5	-- -- -- 6.9, 1.5	TBD. -- TBD. TBD.	mA	
I _{BATT+}	Average current Voice call @maximum Pout	GSM850/EGSM 900 ⁹	198.5	212	200	210	220	220	280	--	--	--	--	mA	
		GSM 1800/1900 ¹⁰	139.5	152	150	155	160	150	150	--	--	--	--		
		UMTS Band II	--	--	--	--	795	670	615	--	--	--	--		
		UMTS Band VIII	--	--	--	--	600	--	605	--	--	--	--		
	Average current Data @maximum Pout	GPRS 1Tx, 4Rx GSM 850/900 ⁹	161.1	202	180	188	220	220	290	--	--	--	--	255	mA
		GSM 1800/1900 ¹⁰	120.2	141	145	137	155	155	160	--	--	--	--	195	
		GPRS 2Tx, 3Rx GSM 850/900 ⁹	246.7	285	330	265	300	300	370	--	--	--	--	440	mA
UMTS Band I Band II Band IV Band V Band VI Band VIII	162.8 211 260 210	215 215 215 215	220 220 220 220	220 220 220 220	220 220 220 220	220 220 220 220	220 220 220 220	220 220 220 220	-- -- -- --	-- -- -- --	-- -- -- --	-- -- -- --	330 440 440 440	mA	

⁶ Measurements start 6 minutes after the module was switched ON, Averaging times: SLEEP mode - 3 minutes; IDLE mode - 1.5 minutes, Communication tester settings: no neighbor cells, no cell reselection etc.

⁷ USB disconnected

⁸ Power save mode is disabled via AT command (AT^SPOW=1,0,0)

⁹ Power control level PCL 5

¹⁰ Power control level PCL 0

Parameter	Description	Conditions	BGS1	BGS12	BGS2	BGS5	EHS5	EHS6, EHS8 ³	ELS61, ELS81 ^{4,5}	ELS31	EMS31	Cinterion® ENS22	EXS82	Unit	
I _{BATT+}	Average current Data @maximum Pout	LTE	--	--	--	--	--	--	720	810	--	--	150 (M1)	mA	
		B1	--	--	--	--	--	--	700	--	225	--	150 (M1)		
		B2	--	--	--	--	--	--	700	--	--	230 (NB1)	147 (M1)		
		B3	--	--	--	--	--	--	720	810	240	--	147 (M1)		
		B4	--	--	--	--	--	--	580	--	--	205 (NB1)	160 (M1)		
		B5	--	--	--	--	--	--	665	--	--	220 (NB1)	158 (M1)		
		B8	--	--	--	--	--	--	670	--	210	--	152 (M1)		
		B12	--	--	--	--	--	--	--	700	220	--	160 (M1)		
		B13	--	--	--	--	--	--	--	--	--	--	--		154 (M1)
		B14	--	--	--	--	--	--	--	700	--	--	--		160 (M1)
		B18	--	--	--	--	--	--	--	700	--	--	--		160 (M1)
		B19	--	--	--	--	--	--	--	--	700	--	--		160 (M1)
		B20	--	--	--	--	--	--	--	625	--	--	205 (NB1)		160 (M1)
		B25	--	--	--	--	--	--	--	--	--	--	--		149 (M1)
		B26	--	--	--	--	--	--	--	--	--	--	--		160 (M1)
		B27	--	--	--	--	--	--	--	--	--	--	--		161 (M1)
		B28	--	--	--	--	--	--	--	620	--	--	290 (NB1)		154 (M1)
		B66	--	--	--	--	--	--	--	--	--	--	--		147 (M1)
		B71	--	--	--	--	--	--	--	--	--	--	--		TBD. (NB)
B85	--	--	--	--	--	--	--	--	--	--	--	TBD. (M1)			
I _{BATT+}	Peak current @maximum Pout	GSM 850/900 ⁹ PCL=5	1.37	2.1	1.30, 1.35 ¹¹	1.35, 1.64 ¹¹	1.4, 1.8 ¹¹	1.6, 1.8 ¹¹	2.4	--	--	--	TBD.	A	
		GSM 1800/1900 ¹⁰ , PCL=0	1.03	1.24	0.95, 0.97 ¹¹	1.1, 1.2 ¹¹	1.1, 1.1 ¹¹	1.3, 1.3 ¹¹	1.6	--	--	--	TBD.		

¹¹ Maximum current at maximum antenna mismatch.

3.3 Application Interface

3.3.1 ON (and AUTO_ON) Signal

The ON signal starts the module. Differences are shown in the following table. ON switch-on circuits are shown in the respective Hardware Interface Descriptions. Note that the ON signal may not be supported by some earlier EHS5, EHS6 and EHS8 firmware versions. Please refer to the Release Notes to find out whether your version supports the ON signal.

For EHS5, EHS6 and EHS8 modules, it is also possible to use an AUTO_ON line as start-up signal to avoid the dedicated ON pulse timing.

Table 6: ON signal characteristics

Signal	BGS1	BGS12	BGS2	BGS5	EHS5, EHS6, EHS8	ELS61, ELS81	ELS31	EMS31	Cinterion® ENS22	EXS82
VDDL	2.8V	3V	2.3V	2.3V	1.8V	1.8V	Not supported	Not supported	Not supported	Not supported
ON: V_{IHmax}	3.3V (VDDL+0.5V)	4.5V	2.8V (VDDL+0.5V)	2.6V (VDDL+0.3V)	2.1V	5V tolerant	5.5V	5.5V	4.2V	VBATT
ON: V_{IHmin}	1.2V	1.2V	1.2V	1.2V	1.2V	1.3V	1.7V ¹²	1.4V	2.8V	1.3V
ON: V_{ILmax}	0.2V	0.2V	0.4V	0.5V	0.5V	0.5V	1.3V ¹²	0.3V	0.8V	0.5V
Input sensitivity	High pulse (>3s)	High pulse (>2s)	Rising edge triggered	Rising edge triggered	High pulse (50...80µs)	Rising edge triggered	Rising edge triggered	Rising edge triggered	Rising edge triggered	Rising edge triggered
AUTO_ON (Active low signal that starts up module) ¹³	Not supported	Not supported	Not supported	Not supported	V_{IHmax} = VDDL+0.3V V_{IHmin} = 1.2V V_{ILmax} = 0.5V Input sensitivity=Level triggered	Not supported	Not supported	Not supported	Not supported	Not supported

Reference:

- “Hardware Interface Description”: Section “Pad Assignment and Signal Description”

¹² Rating for BATT_BB voltage at 3.3V.

¹³ Note: If AUTO_ON signal is set permanently low (i.e., connected to GND), the module will start up automatically if BATT+ is applied with a rise time of less than 1ms between 2.5V to 3.2V. It will also restart automatically if AT^SMSO is called to switch of the module. To prevent this from happening, the AUTO_ON line should be set to inactive high after module start up.

3.3.2 Common Ignition Circuit for ON (and AUTO_ON) Signal

The common ignition circuit shown in Figure 1 can be used to switch on the module either by using the ON or – in the case of EHS5, EHS6 and EHS8 - the AUTO_ON signal.

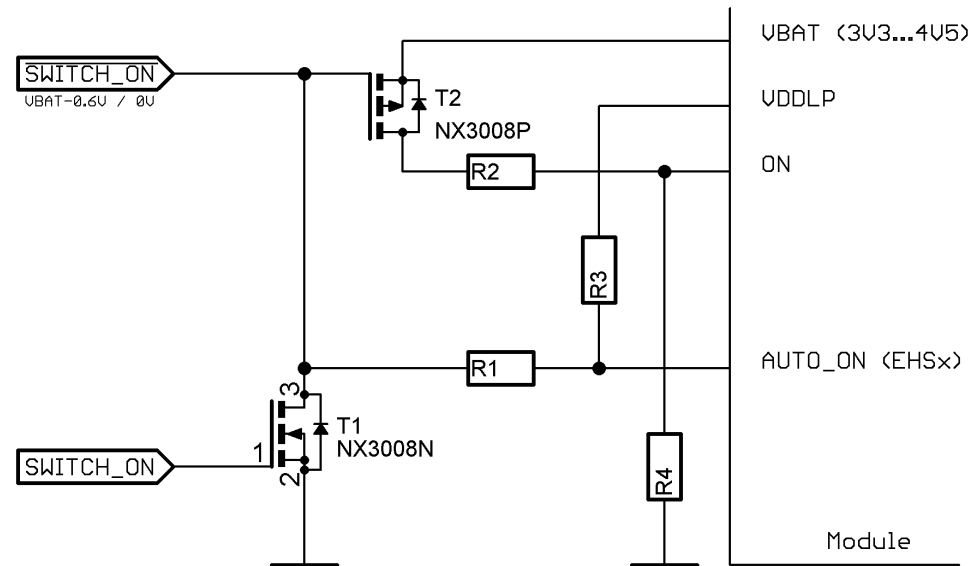

Figure 1: Common ignition circuit

Table 7: Common Ignition circuit component placement

Component	BGS1	BGS12	BGS2	BGS5	EHS5, EHS6, EHS8 ¹⁴	ELS61, ELS81	ELS31	EMS31	Cinterion® ENS22	EXS82
R1	--	--	--	--	0Ω (--)	--	--	--	--	--
R2	6.8kΩ	6.8kΩ	6.8kΩ	6.8kΩ	-- (12k)	0Ω	0Ω	0Ω	0Ω	0Ω
R3	--	--	--	--	10kΩ (--)	--	--	--	--	--
R4	10k	10k	10k	10k	-- (10k)	--	--	--	--	--
Required transistor	T2	T2	T2	T2	T1 (T2)	T2	T2	T2	T2	T2
Active signal	ON	ON	ON	ON	AUTO_ON (ON)	ON	ON	ON	ON	ON

The component placement options of the common ignition circuit ensure compatibility of the power-on signal. There is therefore no need to adapt the external application software for different modules. Note that while EHSx can be started using AUTO_ON, it is also possible to employ the ON signal if the external application can provide a dedicated pulse timing. With ELS31 it is strongly recommended to use EMERG_RST in conjunction with the startup (see below Section 3.3.3 as well as the appropriate Hardware Interface Description ([1])).

¹⁴ () = Alternative values in brackets apply, if EHSx application is able to employ ON signal.

3.3.3 EMERG_RST

The emergency restart signal restarts the module and causes the loss of all information stored in the volatile memory. Therefore the EMERG_RST line should only be used when, due to serious problems, the software is not responding for more than 5 seconds.

EMERG_RST is triggered by an active low pulse or level longer than 10ms (800ms for EXS82). EMERG_RST should be externally driven by an open collector driver.

BGS12 has an emergency off signal instead of an emergency restart signal, and has to be restarted after an emergency off. With BGS12, the EMERG_RST line is therefore named EMERG_OFF. This line is triggered by an active high pulse longer than 10ms, and should be externally driven by an open collector driver.

Table 8: EMERG_RST characteristics

EMERG_RST	BGS1	BGS12	BGS2	BGS5	EHS5, EHS6, EHS8	ELS61, ELS81	ELS31	EMS31	Cinterion® ENS22	EXS82
V _{IHmax}	4.5V	1.9V	1.9V	1.85V	1.9V	1.9V	5.5V	3.6V (<V _{BATT+})	3.3V	TBD.V
V _{IHmin}	0.8V _{BAT}	1.35V	1.35V	1.30V	1.35V	1.35V	0.85V	0.8V	2.1V	1.3V
V _{ILmax}	0.8V	0.2V I(V _{ILmax}) < -25µA at V _{ILmax}	0.2V I(V _{ILmax}) < -150µA at V _{ILmax}	0.35V I(V _{ILmax}) < -105µA at V _{ILmax}	0.35V I(V _{ILmax}) < -130µA at V _{ILmax}	0.35V I(V _{ILmax}) < -130µA at V _{ILmax}	0.65	0.2V	0.6V	0.5V
R _{in}	100kΩ // 100pF	TBD.	1kΩ // 1nF	1kΩ // 1nF ¹⁵	1kΩ // 1nF	1kΩ // 1nF	430kΩ // 1µF	27kΩ // 150pF	1kΩ // 1nF	1kΩ // 1nF
Signal level @ Power down	Low	High	Low	Low	High	Low	Low	Low	Low	Low

Note: With ELS31, it is necessary to trigger EMERG_RST after a module turn off by a sudden (incomplete) power drop, and before using ON to restart the module. For further details see the appropriate Hardware Interface Description ([1]).

Reference:

- “Hardware Interface Description”: Section “Pad Assignment and Signal Description”

¹⁵ Additional 2.2k pull-up resistor to V180 required.

3.3.4 Power Supply BATT+

The EHSx and ELSx power supply needs an external interference suppression capacitor at the power supply BATT+_{RF} and BATT+_{BB}. Low ESR capacitors should be connected very close to appropriate power supply pads listed below in Table 9.

It is recommended to implement 00hm resistors for both power lines to be able to exchange the 00hm resistors with ferrite beads, thus improving interference suppression by reducing self-interference. For ELSx the 00hm resistor should in any case be replaced with a ferrite bead.

BGS1, BGS12, BGS2, BGS5, and Cinterion® ENS22 do not require any additional interference suppression at both power pads.

Table 9: BATT+ power supply pads and interference suppression

BATT+	BGS1, BGS2, BGS12	BGS5	EHS5	EHS6, EHS8	ELS61, ELS81	ELS31	EMS31	Cinterion® ENS22	EXS82
Pad 5	BATT+ _{BB} No interference suppression	BATT+ No interference suppression	BATT+ _{BB} Interference suppression 150µF low ESR	---	---	BATT_RF Interference suppression 150µF low ESR	BATT+ No interference suppression	BATT+ _{BB} No interference suppression	BATT+ _{BB} Interference suppression 47µF low ESR
Pad 53	BATT+ _{RF} No interference suppression	BATT+ No interference suppression	BATT+ _{RF} Interference suppression 47µF low ESR	BATT+ _{RF} Interference suppression 150µF low ESR	BATT+ _{RF} Interference suppression 150µF low ESR	BATT_BB Interference suppression 47µF low ESR	BATT+ No interference suppression	BATT+ _{RF} No interference suppression	BATT+ _{RF} Interference suppression 150µF low ESR
Pad 204	--	---	---	BATT+ _{BB} Interference suppression 47µF low ESR	BATT+ _{BB} Interference suppression 47µF low ESR (150µF low ESR as of Rel.2) (plus noise blocking filter BLM18EG221/1nF/100nF)	---	---	---	---

The following figure shows a possible sample external interference suppression circuit and its varying components.

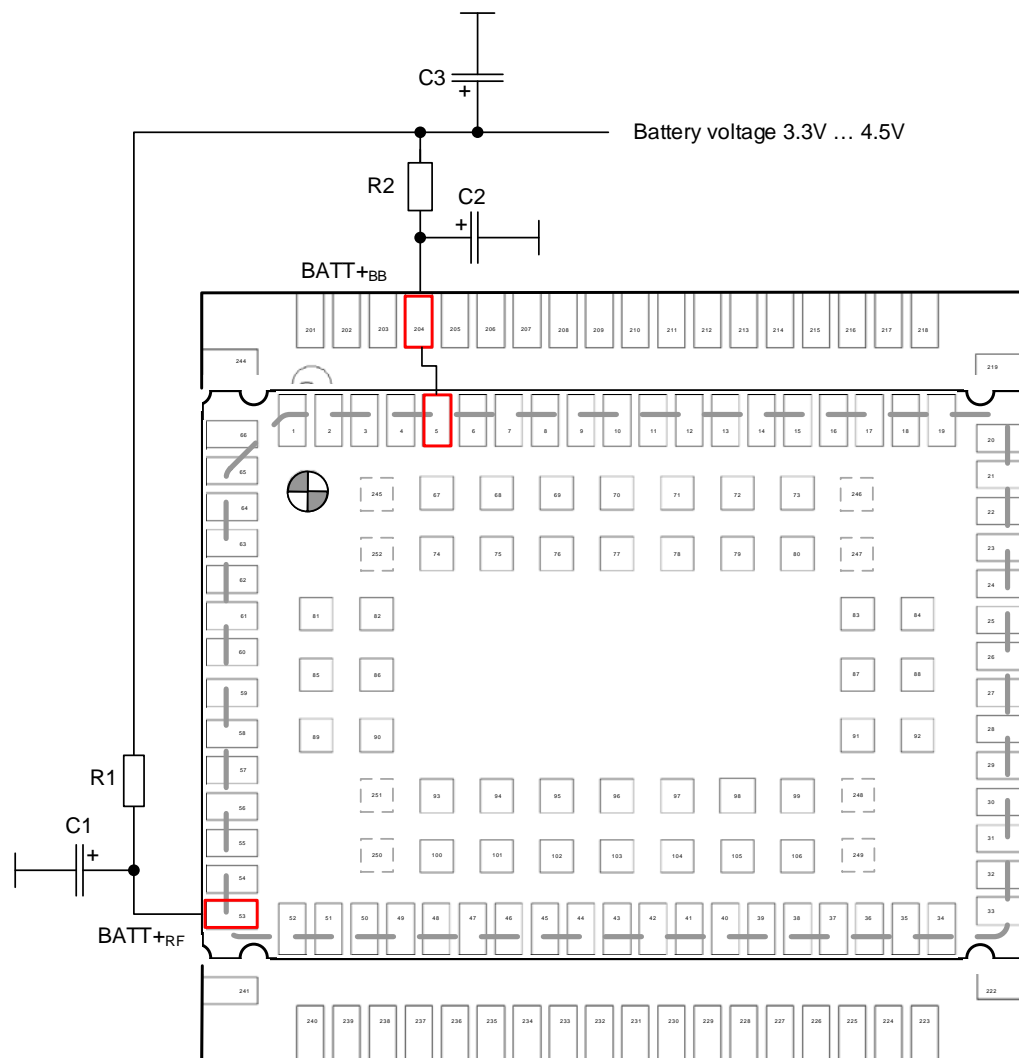

Figure 2: BATT+ and external interference suppression circuit

Table 10: Interference suppression circuit components

Item	BGS1, BGS12	BGS2	BGS5	EHS5	EHS6, EHS8	ELS61	ELS31	EMS31	Cinterion® ENS22	EXS82
C2	--	--	--	1nF low ESR	1nF low ESR	1nF low ESR	1nF low ESR	---	---	TBD.
C1	--	--	--	47µF low ESR	150µF low ESR	150µF low ESR	47µF low ESR	---	---	TBD.
C3	--	---	---	150µF low ESR	47µF low ESR	47µF low ESR (150µF low ESR as of Rel.2)	150µF low ESR	---	100µF(or 2x47µF) low ESR	TBD.
R1	0R	0R	0R	0R	0R	0R	0R	0R	0R	0R
R2	0R	0R	0R	0R	0R	Ferrite bead BLM18EG221	0R	0R	0R	0R

3.3.5 Voltage Domain VDIG, V180, V285/VCORE

With BGS1 and BGS2 the VDIG line is used as input reference to set the IO voltage domain for the ASC0, DAI and I²C interfaces – and is either connected to V180 or V285. BGS5, EHSx, ELSx, and EMS31 have a fixed IO voltage domain of 1.8V, BGS12 has a fixed IO voltage domain of 2.8V, and Cinterion® ENS22 has a fixed IO voltage domain of 3.0V. The VDIG line is in these cases no longer applicable.

For compatibility reasons and migration purposes, it is recommended to configure the BGS2 IO voltage domain to 1.8V.

Table 11: Voltage domain configuration

Voltage domain	BGS1	BGS12	BGS2	BGS5	EHS5, EHS6, EHS8	ELS61, ELS81	ELS31	EMS31	Cinterion® ENS22	EXS82
VDIG	Applicable	Not applicable	Applicable	Not applicable	Not applicable	Not applicable	Not applicable	Not applicable	Not applicable	Not applicable
V180 or V300 (Cinterion® ENS22)	1.8V ±5% I _o max: 10mA	Not applicable	1.8V ±5% I _o max: 10mA	1.8V ±5% I _o max: 10mA	1.8V ±5% I _o max: 10mA	1.8V ±5% I _o max: 10mA	1.8V ±5% I _o max: 50mA	1.8V ±5% I _o max: 50mA ¹⁶	3.0V ±5% I _o max: 10mA	1.8V ±TBD.% I _o max: TBD.mA
V285 / VCORE	V285: 2.85V	Not applicable	V285: 2.85V	VCORE: 0.9...1.25V	VCORE: 0.9...1.2V	VCORE: 0.9V...1.2V	VCORE: 1.09V...1.12V	VCORE: 1.045V...1.155V I _o max: 50mA	Not applicable	TBD.
IO domain	Configurable 1.8V / 2.85V	Fixed 2.8V	Configurable 1.8V / 2.85V	Fixed 1.8V	Fixed 1.8V	Fixed 1.8V	Fixed 1.8V	Fixed 1.8V	Fixed 3.0V	Fixed 1.8V

¹⁶ Please note that with EMS31 the V180 line is switched off if the module is in SUSPEND mode (i.e. in a specific a deep sleep mode).

3.3.6 Power Indication Circuit

External level shifters or power sources need to be controlled in a safe way to prevent back feeding while the module is in Power Down mode. Generally, it is recommended to control those shifters or sources by means of the V180 line¹⁷. If back feeding cannot be prevented via V180 line, a more sophisticated power indication signal should be used instead.

As V180 and V285/VCORE have a slightly different start-up and shutdown timing, it is recommended to implement an external circuit to realize an optimized power indication signal (PWR_IND) if needed. This circuit as illustrated in Figure 3 uses the same signals for all modules. The V285/VCORE pad is located at the same position for all modules. Please be aware that realizing a more sophisticated power indication signal will consume additional power, even though the below circuit is not optimized for ultra-low current consumption as may be required for EXS82.

Also note that BGS12 and Cinterion® ENS22 do not support V285/VCORE and have V280 and V300 instead of V180. A dedicated power indication circuit for BGS12 and Cinterion® ENS22 is show in Figure 4.

Table 12: Power indication circuit components

Voltage domain	BGS1	BGS12	BGS2	BGS5	EHS5, EHS6, EHS8	ELS61, ELS81	ELS31	EMS31	Cinterion® ENS22	EXS82
V180 or V280 (BGS12) or V300 (Cinterion® ENS22)	1.8V	2.8V	1.8V	1.8V	1.8V	1.8V	1.8V	1.8V	3V	1.8V
V285 / VCORE	V285: 2.85V	--	V285: 2.85V	VCORE: 0.9..1.25V	VCORE: 0.9..1.2V	VCORE: 0.9...1.2V	VCORE: 1.1V	VCORE: 1.045V...1.155V	--	VCORE: TBD.V
R1	22k	--	22k	22k	22k	22k	22k	--	--	22k
R2	22k...100k	--	22k...100k	47k...100k	47k...100k	47k...100k	47k...100k	--	--	47k...100k
R3	22k	--	22k	4.7k	4.7k	4.7k	4.7k	4.7k	--	4.7k
R4	22k...47k	--	22k...47k	47k...100k	47k...100k	47k...100k	47k...100k	47k	--	47k...100k
R5	10k...100k	--	10k...100k	10k...100k	10k...100k	10k...100k	10k...100k	470k...1M	--	10k...100k
R6	--	47k	--	--	--	--	--	--	47k	
R7	--	100k	--	--	--	--	--	--	100k	
R8	--	100k	--	--	--	--	--	--	100k	

¹⁷ Please note that with EMS31 the V180 line is switched off if the module is in SUSPEND mode (i.e. in a specific a deep sleep mode). Also, with Cinterion® ENS22 the V300 line is switched of if the module is in power down mode.

Voltage domain	BGS1	BGS12	BGS2	BGS5	EHS5, EHS6, EHS8	ELS61, ELS81	ELS31	EMS31	Cinterion® ENS22	EXS82
T1/T2 ¹⁸ /T3	BCR148S, BCR141S R1'=0Ω	BC847	BCR148S, BCR141S R1'=0Ω	BCR116S R1'=18kΩ	BCR116S R1'=18kΩ	BCR116S R1'=18kΩ	BCR116S R1'=18kΩ	BC847	BC847	BCR116S R1'=18kΩ

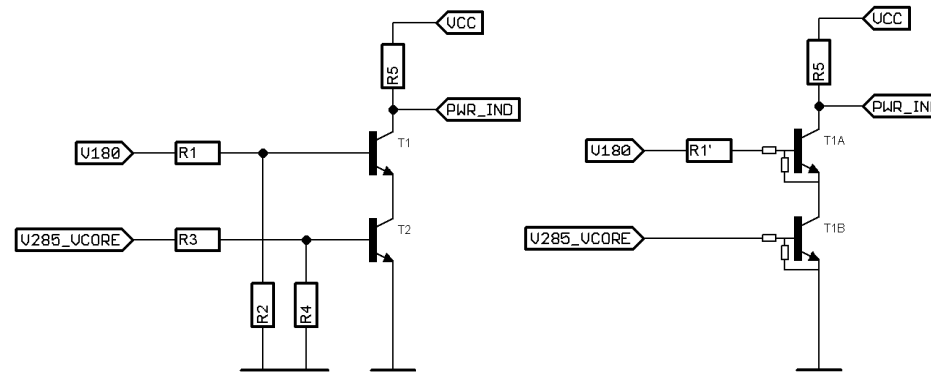

Figure 3: Power indication circuit

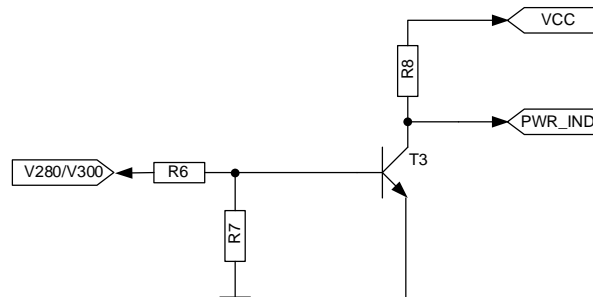

Figure 4: Power indication circuit for BGS12 (V280) and Cinterion® ENS22 (V300) only

¹⁸ As an alternative to implementing the power indication circuit with the specified resistors and standard transistors as shown in the left circuit of Figure 3, it is possible to employ digital transistors with build in resistors as shown in the right circuit, thus saving some components and space. In such case R2 can also be connected to emitter of T1.

3.3.7 RTC Backup VDDL

The power supply pad VDDL can be used to back up the internal RTC from an external capacitor.

Table 13: Power indication circuit components

VDDL signal	BGS1	BGS12	BGS2	BGS5	EHS5, EHS6, EHS8	ELS61, ELS81	ELS31, EMS31, Cinterion® ENS22, EXS82
Nominal (max) level	2.8V (4.2V)	3.0V(3.3V)	2.3V (2.4V)	2.3V	1.8V (1.9V)	1.8V (1.9V)	Not supported
Supply current	47µA	170µA	8µA	<2.4µA	<1µA	<1µA	

3.3.8 SIM Interface

BGS5, EHSx, ELS61, and Cinterion® ENS22 have no enhanced ESD protection implemented. It is therefore recommended to implement an additional ESD protection close to the SIM card holder as shown in Figure 5. Please note that the eSIM option of Cinterion® ENS22-E Rel.1.1 does not support an external SIM interface, but has an internal eSIM on the module.

Note to use very low capacitive protection elements, like NUP4114 or NUP4201MR6.

BGS1, BGS2, and EMS31 require a 4.7kOhm pull-up resistor at the CCIO line.

Table 14: SIM interface – enhanced ESD protection

SIM interface	BGS1	BGS12	BGS2	BGS5	EHS5, EHS6, EHS8	ELS61, ELS81	ELS31	EMS31	Cinterion® ENS22	EXS82
Enhanced Internal ESD protection	Implemented	Implemented	Implemented	Not implemented	Not implemented	Not implemented	Implemented	Implemented	Not implemented	Not implemented
4.7kOhm pull-up resistor at CCIO line	Required	Not required	Required	Not required	Not required	Not required	Not required	EMS31-V: Required EMS31-US/-X: Not required	Not required	Not required
CCIN usage (SIM inserted)	High	High	High	High	High	High	High	High	Not required	High

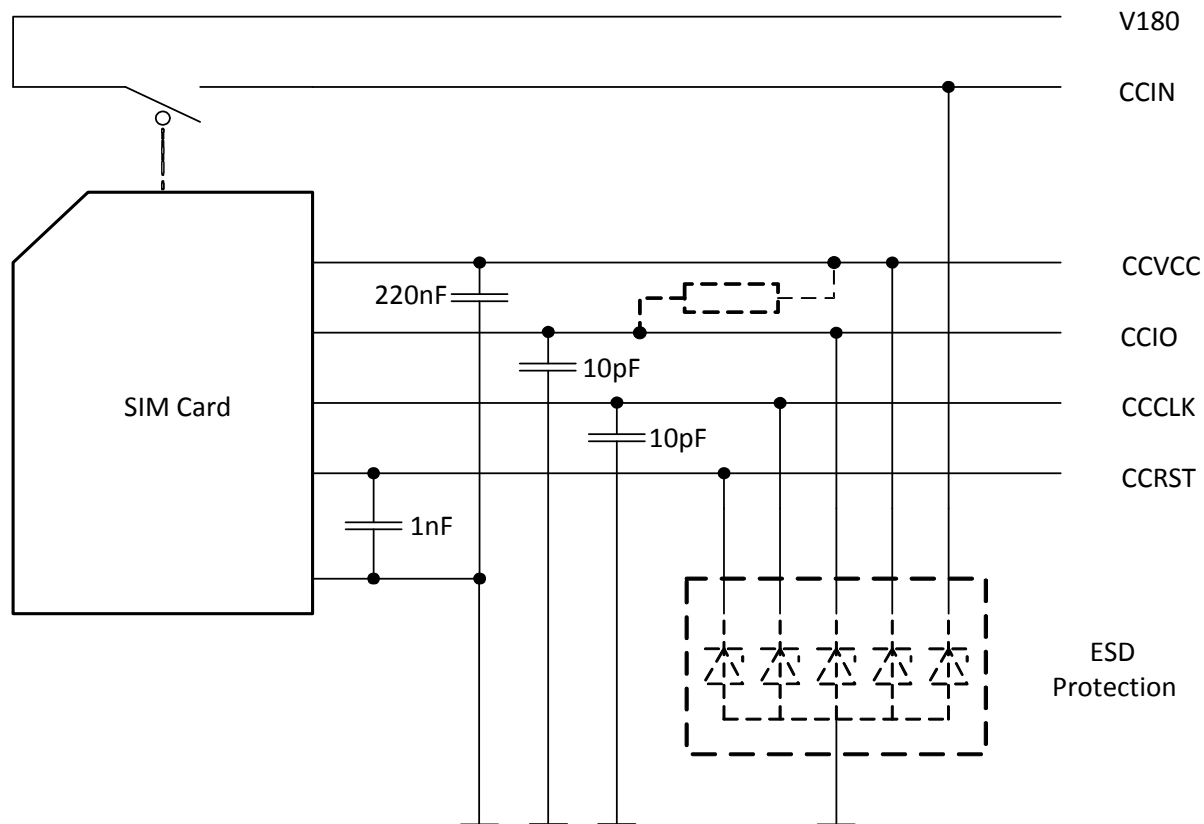

Figure 5: SIM interface - enhanced ESD protection

Reference:

- “Hardware Interface Description”: Section “SIM Interface”

3.3.9 Second SIM interface

EMS31 supports a second SIM interface – External SIM or embedded SIM.

Only one SIM can be operated at given time. Please note that the 2nd SIM interface is currently only hardware prepared.

3.3.10 USB Interface

BGS5 supports a full speed USB 2.0 interface, whereas EHSx, and ELS61/ELS81 support a high speed 2.0 USB interface. For high speed operation, special attention should be given to USB data line routing. The external application layout should in this case implement a differential impedance of 90Ω for proper signal integrity.

The pads used as USB pads with BGS5, EHS5, ELS31, EXS82 are connected to GND with BGS1 and BGS2, and internally not connected with BGS12. It is therefore recommended to place 0Ω resistors at the USB signal lines (USB_DN, USB_DP, VUSB) to be able to activate USB support in a combined PCB layout. If either release of BGS1, or BGS2 is mounted, the 0Ω resistors are not equipped. Vice versa, if BGS5, EHS5, ELS31, EXS82 are mounted, these resistors should be implemented.

Also, in a combined PCB layout with BGS5/EHS5/ELS31/EXS82 and EHS6/EHS8/ELS61/ELS81, i.e., with pad count LGA106/114 and LGA120, is it necessary to place 0Ω serial resistors at the USB_DN and USB_DP lines to avoid the stubs in the EHS5 design by not mounting the 0Ω resistors.

Table 15: USB interface

USB interface	BGS5	EHS5, EHS6, EHS8	ELS61, ELS81	ELS31	EXS82	BGS1, BGS12, BGS2, EMS31, Cinterion® ENS22
USB	Supported	Supported	Supported	Supported	Supported for debugging purposes only	Not supported

An external ESD protection should be provided for the BGS5, EHSx, and ELS61/ELS81 USB interfaces.

Reference:

- “Hardware Interface Description”: Section “USB Interface”

3.3.11 ASC0 Interface

The voltage levels at the ASC0 interface lines are identical for all modules as long as VDIG is connected to V180 for BGS2. Same condition applies to BGS1. **Note:** BGS12 and Cinterion® ENS22 are exceptions, because VDIG/VCORE are not supported, and the voltage level at the ASC0 lines is fixed at 2.8V for BGS12 or 3.0V for Cinterion® ENS22.

An external application may not require and employ the ASC0 interface, however, it is highly recommended that test points are provided at all ASC0 (UART) pads for easier debugging when necessary.

The following tables show ASC0 interface differences between the modules.

Table 16: ASC0 transfer rates

ASC0 interface	BGS1	BGS12	BGS2	BGS5	EHS5, EHS6, EHS8	ELS61, ELS81	ELS31	EMS31	Cinterion® ENS22	EXS82
UART lines	8 lines	8 lines	8 lines	8 lines	8 lines	8 lines	8 lines	8 lines	8 lines	8 lines
Baud rate range	1200 ...230400	4800 ...230400	300 ...230400	1200 ...921600	1200 ...921600	1200...921600 (Rel.1: up to 3Mbit)	4800 ...921600	1200 ...3686400	1200 ...921600	300 ...921600
Autobauding Range	Yes 1200 ...230400	Yes 4800 ...230400	Yes 1200 ...230400	Yes 1200 ...230400	Yes 1200 ...230400	Yes 1200 ...230400	No --	No --	No --	No --
RTS0 wake-up	Supported	Supported	Supported	Supported	Supported	Supported	Supported	Supported ¹⁹	Supported	Supported

Table 17: ASC0 start-up/reset signal states²⁰

ASC0 lines	BGS1	BGS12	BGS2	BGS5	EHS5, EHS6, EHS8	ELS61, ELS81	ELS31	EMS31	Cinterion® ENS22	EXS82
RXD0	T / 60K PU	T	T / PU -204µA at 0V	T / PU -220µA at 0V	T / PU -240µA at 0V	T / PU -240µA at 0V	T <1µA at 1.8V	I / PU -36µA at 0V	T / No pull	TBD.

¹⁹ Please note that with EMS31, RTS0 or GPIO25 will wake up the module in SUSPEND mode (i.e. in a specific deep sleep mode), depending on configuration by AT^SCFG command.

²⁰ T = Tristate; PU = Pull-up; PD = Pull-down

ASC0 lines	BGS1	BGS12	BGS2	BGS5	EHS5, EHS6, EHS8	ELS61, ELS81	ELS31	EMS31	Cinterion® ENS22	EXS82
TXD0	T / 60K PU	T	T / PU -204µA at 0V	T / PD +150µA at 1.85V	T / PD +200µA at 1.9V	T / PD +200µA at 1.9V	I <1µA at 1.8V	I / PU -36µA at 0V	T / No pull	TBD.
CTS0	T / 60K PD	I / 166K PD	T / PD +51µA at 1.75V	T / PD +43µA at 1.85V	T / PU -240µA at 0V	T / PU -240µA at 0V	T <1µA at 1.8V	I / PU -36µA at 0V	T / No pull	TBD.
RTS0	T / 60K PU	I / 166K PD	T / 10k PU	T / PU -55µA at 0V	T / PU -240µA at 0V	T / PU -240µA at 0V	I <1µA at	I / PD +18µA at 1.8V	T / No pull	TBD.
DTR0	T / 60K PU	I / 166K PD	Rel1 T / PD +103µA at 1.75V Rel1 T / PU -102µA at 0V	T / PD +83µA at 1.85V	T / PD +200µA at 1.9V	T / PD +200µA at 1.9V	I <1µA at 1.8V	I / PU -18µA at 0V	T / No pull	TBD.
DCD0	T / 60K PU	I / 166K PD	T / PU -102µA at 0.05V	T / PD +43µA at 1.85V	T / PD +200µA at 1.9V	T / PD +200µA at 1.9V	T <1µA at 1.8V	I <+1µA at 1.8V	T / No pull	TBD.
DSR0	T / 60K PU	I / 166K PD	Rel1 T / PD +27µA at 1.75V Rel2 T / PU -102µA at 0.05V	T / PU -105µA at 0V	T / PD +200µA at 1.9V	T / PD +200µA at 1.9V	T <1µA at 1.8V	I <+1µA at 1.8V	T / No pull	TBD.
RING0	T / 70K PU	I / 166K PD	T / 10k PU	T / PU -200µA at 0V	T / PD +200µA at 1.9V	T / PD +200µA at 1.9V	T <1µA at 1.8V	I <+1µA at 1.8V	T / No pull	TBD.

For more information on the interface and its start-up timings please refer to the respective “Hardware Interface Description”.

3.3.12 ASC1 Interface

With BGS1, BGS12, BGS2, autobauding is not supported. With ELS31, ASC1 is not supported as AT command interface, only as data interface. With BGS12, ASC1 is only supported for firmware update and tracing. The below tables show ASC1 interface differences between the modules.

Table 18: ASC1 transfer rates

ASC1 interface	BGS1	BGS12	BGS2	BGS5	EHS5, EHS6, EHS8	ELS61, ELS81	ELS31	EMS31	Cinterion® ENS22	EXS82
UART lines	4 lines	2 lines	4 lines	4 lines	4 lines	4 lines	4 lines	4 lines	4 lines	4 lines
Baud rate range	1200 ...230400	921600	300 ...230400	1200 ...921600	1200 ...921600	1200 ...921600	4800 ...921600	1200 ...3686400	1200 ...921600	300 ...921600
Autobauding Range	No ---	No ---	No ---	Yes 1200 ...230400	Yes 1200 ...230400	Yes 1200 ...230400	No --	No --	No --	No --
RTS1 wake-up	Not supported	Not supported	Not supported	Not supported	Not supported	Not supported	Supported	Supported ²¹	Not supported	TBD.

Table 19: ASC1 start-up/reset signal states

ASC1 lines	BGS1	BGS12	BGS2	BGS5	EHS5, EHS6, EHS8	ELS61, ELS81	ELS31	EMS31	Cinterion® ENS22	EXS82
RXD1	T / 60K PU	O/H 2.8V	T / PD +51µA at 1.75V	T / PD +43µA at 1.85V	T / PU -240µA at 0V	T / PU -240µA at 0V	T <1µA at 1.8V	I / PU -36µA at 0V	T / No pull	TBD.
TXD1	T / 60K PU	I/166K PU 2.8V	T / PD +51µA at 1.75V	T / PD +43µA at 1.85V	T / PD +200µA at 1.9V	T / PD +200µA at 1.9V	I <1µA at 1.8V	I / PU -36µA at 0V	T / No pull	TBD.
CTS1	T / 60K PD	Not supported	T / PD +51µA at 1.75V	T / PD +43µA at 1.85V	T / PD +200µA at 1.9V	T / PU -240µA at 0V	T <1µA at 1.8V	I / PU -36µA at 0V	T / No pull	TBD.
RTS1	T / 60K PU	Not supported	T / PU -102µA at 0V	T / PU -55µA at 0V	T / PD +200µA at 1.9V	T / PU -240µA at 0V	I <1µA at 1.8V	I / PU -18µA at 0V	T / No pull	TBD.

For more information on the interface and its start-up timings please refer to the respective “Hardware Interface Description”.

²¹ Please note that with EMS31, RTS1 will not wake up the module in SUSPEND mode (i.e. in a specific deep sleep mode). Instead ON signal should be used.

3.3.13 ASC2 Interface

The following tables show ASC2 interface differences between the modules.

Table 20: ASC2 transfer rates

ASC2 interface	BGS12	BGS1, BGS2, BGS5, EHS5, EHS6, EHS8, ELS61, ELS81, ELS31, EMS31, Cinterion® ENS22, EXS82
UART lines	4 lines	Not supported
Baud rate range	4800 ...230400	
Autobauding range	No ---	
RTS2 wake-up	Supported	

Table 21: ASC2 start-up/reset signal states

ASC2 lines	BGS12	BGS1, BGS2, BGS5, EHS5, EHS6, EHS8, ELS61, ELS81, ELS31, EMS31, Cinterion® ENS22, EXS82
RXD2	I / 166K PD	Not supported
TXD2	I / 166K PD	
CTS2	I / 33K PD	
RTS2	I / 33K PD	

3.3.14 I²C Interface

With BGS1, BGS12, BGS2, and Cinterion® ENS22 the I²C interface lines are shared with GPIO lines and may also be configured as GPIO9 and GPIO10. BGS5, EHSx, ELSx, and EMS31 have dedicated I²C interface lines²². For compatibility reason and migration purposes, the GPIO functionality on GPIO9 and GPIO10 should therefore not be used with BGS1, BGS12, BGS2, or Cinterion® ENS22 modules.

The I2CDAT and I2CCLK lines have to connect via pull-up resistors to a positive supply voltage, for example from the module: V180 (EHSx and ELSx), V180/V285 (BGS1, BGS2), V280 (BGS12), or V300 (Cinterion® ENS22).

Table 22: I²C pull-up values (internal or external)

	BGS1	BGS12	BGS2	BGS5	EHS5, EHS6, EHS8	ELS61, ELS81	ELS31	EMS31	Cinterion® ENS22
Internal pull-up I2CCLK	Yes	Yes	Yes	Yes	Yes	Yes	Yes	TBD	Yes
Internal pull-up I2CDAT	Yes	Yes	---	Yes	Yes	Yes	Yes	TBD	Yes
R1 (typical)	4.7kΩ	4.7kΩ	2.2kΩ	2.2kΩ	2.2kΩ	2.2kΩ	2.2kΩ	TBD	2.2kΩ
R2 (typical)	4.7kΩ	4.7kΩ	2.2kΩ	2.2kΩ	2.2kΩ	2.2kΩ	2.2kΩ	TBD	2.2kΩ
R1min	TBD.	TBD.	>560Ω	>560Ω	>560Ω	>560Ω	>390Ω	TBD	>560Ω
R2min	TBD.	TBD.	>510Ω	>560Ω	>560Ω	>560Ω	>390Ω	TBD	>560Ω

²² Note that the I²C interface is not supported with the following products: EHS5 Release 1, EXS82 Release 1, and Cinterion® ENS22-E Release 1.1.

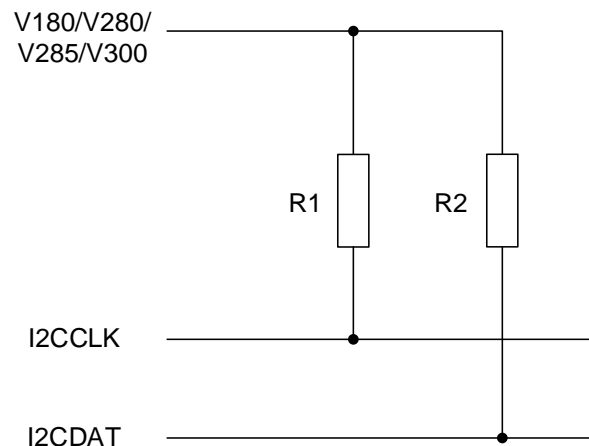

Figure 6: I2C pull-up resistors on external application

Table 23: I²C start-up/reset signal states

I ² C interface lines	BGS1	BGS12	BGS2	BGS5	EHS5, EHS6, EHS8	ELS61, ELS81	ELS31	EMS31	Cinterion® ENS22
I2CCLK	T / 60K PD	T	T / 5k PU	T	T	T / PU	T / PD	I / PU	T / No pull
I2CDAT	T / 60K PD O/L (reset)	T	T	T	T	T / PU	T / PD	I / PU	T / No pull

For more information on the interface and its start-up timings please refer to the respective “Hardware Interface Description”.

3.3.15 SPI Interface

BGS5, EHSx, ELSx, EMS31, and Cinterion® ENS22 support a Serial Peripheral Interface (SPI)²³. The SPI lines are shared with GPIO and serial interface lines, the configuration is done by AT command. ELS31 has dedicated SPI lines, but these are shared with the internal Flash memory - hence the SPI data throughput might be reduced in cases of heavy internal flash read/write processes.

Table 24: SPI interface

	BGS5	EHS5 EHS6, EHS8	ELS61, ELS81	ELS31	EMS31	Cinterion® ENS22	BGS1, BGS12, BGS2, EXS82
SPI interface	Supported	Supported	Supported	Supported	Supported	Supported	Not supported
- Mode	Master	Master	Master	Master	Master	Master	
CS signal	1	1	1	2	2	1	--
Speed	< 6.5Mbit/s	< 6.5Mbit/s	< 6.5Mbit/s	< 6.5Mbit/s	< 13Mbit/s	< 800Kbit/s	--
Sharing	GPIO16,17,18,19	GPIO3,16,17,19	GPIO3,16,17,19	Internal Flash	GPIO 26,27	GPIO16,17,18,19	--

For more information on the interface please refer to the respective “Hardware Interface Description”.

3.3.16 HSIC Interface

EHS6, EHS8 support a High Speed Inter-Chip (HSIC) interface.

For more information on the HSIC interface please refer to the “Hardware Interface Description”.

²³ Please note that the SPI interface is not supported with the following products: EHS5 Release 1, and Cinterion® ENS22-E Release 1.1.

3.3.17 Audio Interface

Table 25: Audio interfaces overview

BGS1, BGS12	BGS2	BGS5	EHS5, EHS6, EHS8	ELS61, ELS81	ELS31	EMS31, Cinterion® ENS22, EXS82
Analog	Analog / Digital	Digital	Analog (EHS6-A only) / Digital	Digital (ELS61-E R2 and ELS61-USA only) with VoLTE and fall back 2G	Digital with VoLTE	Not supported

3.3.18 Digital Audio Interface

With BGS2, BGS5 and EHSx, there are no differences regarding the voltage level of the digital audio interface (DAI) lines.

The digital audio interface is implemented as a pulse code modulation (PCM) and/or Inter-IC sound (I²S) interface. Characteristics are listed in the table below.

Table 26: PCM characteristics

Characteristics	BGS2	BGS5	EHS5, EHS6, EHS8	ELS61, ELS81 ²⁴	ELS31	BGS1, BGS12, EMS31, Cinterion® ENS22, EXS82
Digital Audio mode	PCM master mode, 256kHz clock, long frame	PCM master mode, 256kHz clock, long frame	PCM master mode, 256kHz clock, long frame EHS6: I ² S mode (Rel.3 update)	ELS61-E Rel.2, ELS61-USA: PCM/I ² S master/slave mode, long/short frame 8 kHz sampling rate: 264 kHz (PCM short frame), 256 kHz and 520 kHz bit clock 16 kHz sampling rate: 528 kHz (PCM short frame), 512 kHz and 1040 kHz bit clock	ELS31-VA: PCM/I ² S slave mode, long/short frame 8 kHz sampling rate: 264, 256, 512, 1024, 2048, 4096 kHz bit clock 16 kHz sampling rate: 256, 512, 1024, 2048, 4096 kHz bit clock	Not supported

²⁴ Only ELS61-E R2 and ELS61-USA are supported.

The DAI start-up behaviour differs slightly between the module variants as shown in the table below.

Table 27: DAI start-up/reset signal states

DAI interface lines	BGS12	BGS2	BGS5	EHS5, EHS6, EHS8	ELS61, ELS81 ²⁴	ELS31	BGS1, EMS31, Cinterion® ENS22, EXS82
RXDDAI	T	T / PD +51µA at 1.75V	T / PD +150µA at 1.8V	T / PD +200µA at 1.9V	T / PD (GPIO) +200µA at 1.9V	I <1µA at 1.8V	Not supported
TXDDAI	T	T / PD +51µA at 1.75V	T / PD +150µA at 1.8V	T / PD +200µA at 1.9V	T / PD (GPIO) +200µA at 1.9V	I <1µA at 1.8V	
TFSDAI (FSYNC0)	T	T / PD +51µA at 1.75V	T / PD +150µA at 1.8V	T / PD +200µA at 1.9V	T / PD (GPIO) +200µA at 1.9V	I <1µA at 1.8V	
SCLK (SCLK0)	T	T / PU -55µA at 0V	T / PD +150µA at 1.8V	T / PD +200µA at 1.9V	T / PD (GPIO) +200µA at 1.9V	I <1µA at 1.8V	

For more information on the interface and its start-up timings please refer to the respective “Hardware Interface Description”.

3.3.19 Analogue Audio Interface

With BGS5 an analogue audio interface is hardware prepared for future use.

Table 28: Analogue audio interface

Analogue interface	BGS1	BGS12	BGS2	EHS6-A	BGS5, EHS5, EHS6, EHS8, ELS31, ELS61, ELS81, EMS31, Cinterion® ENS22 EXS82
Analogue Audio Interface	Supported	Supported	Supported	Supported	Not supported
VMIC	2.3V max 1 mA	1.8V	1.8V ... 2.2V, max 4mA	2.7V±5.5% max 3mA	
MICP1	Z _{ltyp} = 20kΩ	Z _{ltyp} = 2kΩ	R _i = 50kOhm V _{in} max 0.8Vpp	R _{ip} = 94kOhm with 0dB gain R _{in} = 5.6kOhm with 30dB gain V _{in} max = 0.7V	
MICN1	R _i = 20kOhm V _{in} max 6Vpp	Z _{ltyp} = 2kΩ			
AGND	AGND	AGND	AGND	AGND	
EPP1	4.5Vpp at 32Ohm load	Max. 1.3Vrms at 32Ohm load 0.95kHz sine wave	3.2Vpp on 16Ohm load	Max. 5Vpp at 16Ohm load	
EPN1					

3.3.20 GPIO Interface

Table 29: GPIO lines^{25, 26}

GPIOs	BGS1	BGS12	BGS2	BGS5	EHS5	EHS6, EHS8	ELS61, ELS81	ELS31	EMS31	Cinterion® ENS22
GPIO1	-- / DTR0 (rel.2)	-- / DTR0	-- / DTR0	GPIO1 / DTR0	GPIO1 / DTR0	GPIO1 / DTR0	GPIO1 / DTR0	GPIO1 / DTR0	GPIO1 / DTR0	GPIO1 / DTR0
GPIO2	-- / DCD0 (rel.2)	-- / DCD0	-- / DCD0	GPIO2 / DCD0	GPIO2 / DCD0	GPIO2 / DCD0	GPIO2 / DCD0	GPIO2 / DCD0	GPIO2 / DCD0	GPIO2 / DCD0
GPIO3	-- / DSR0 (rel.2)	-- / DSR0	-- / DSR0	GPIO3 / DSR0	GPIO3 / DSR0 / SPI_CLK	GPIO3 / DSR0 / SPI_CLK	GPIO3 / DSR0 / SPI_CLK	GPIO3 / DSR0	GPIO3 / DSR0	GPIO3 / DSR0
GPIO4	-- / FAST_SHDN (rel.2)	-- / FAST_SHDN	-- / FAST_SHDN	GPIO4 / FST_SHDN	GPIO4 / FST_SHDN	GPIO4 / FST_SHDN	GPIO4 / FST_SHDN	GPIO4 / FST_SHDN	GPIO4 / FST_SHDN	GPIO4
GPIO5	GPIO5 / LED	GPIO5 / LED	GPIO5 / LED	GPIO5 / LED	GPIO5 / LED	GPIO5 / LED	GPIO5 / LED	GPO5 / LED	GPIO5 / LED	GPIO5
GPIO6	GPIO6 / PWM2	GPIO6 / Jamming Ind	GPIO6 / PWM2	GPIO6 / PWM2	GPIO6 / PWM2	GPIO6 / PWM2	GPIO6 / PWM2	GPIO6	GPIO6 / PWM2	--
GPIO7	--	GPIO7 / --	GPIO7 / PWM1	GPIO7 / PWM1	GPIO7 / PWM1	GPIO7 / PWM1	GPIO7 / PWM1	GPIO7	GPIO7 / PWM1	--
GPIO8	GPIO8 (rel.2)	GPIO8	GPIO8	GPIO8 / COUNTER	GPIO8 / COUNTER	GPIO8 / COUNTER	GPIO8 / COUNTER	GPIO8 / COUNTER	GPIO8 / COUNTER	GPIO8
GPIO9	GPIO9 / I2CDAT(rel.1) GPIO9 / I2CCLK(rel.2)	GPIO9 / I2CCLK	GPIO9 / I2CCLK	-- / I2CCLK	-- / I2CCLK	-- / I2CCLK	-- / I2CCLK	-- / I2CCLK	-- / I2CCLK	GPIO9 / I2CCLK (rel.1 only)
GPIO10	GPIO10 / I2CCLK (rel.1) GPIO10 / I2CDAT (rel.2)	GPIO10 / I2CDAT	GPIO10 / I2CDAT	-- / I2CDAT	-- / I2CDAT	-- / I2CDAT	-- / I2CDAT	-- / I2CDAT	-- / I2CDAT	GPIO10 / I2CDAT (rel.1 only)
GPIO11	--	--	--	--	--	GPIO11	GPIO11	--	--	--

²⁵ Please note that the GPIO interface is not supported with EHS5 Release 1 and with EXS82.

²⁶ -- = Indicates that the GPIO function is not available, possible alternative functionality is given after a slash.

GPIOs	BGS1	BGS12	BGS2	BGS5	EHS5	EHS6, EHS8	ELS61, ELS81	ELS31	EMS31	Cinterion® ENS22
GPIO12	--	--	--	--	--	GPIO12	GPIO12	--	--	--
GPIO13	--	--	--	--	--	GPIO13	GPIO13	--	--	--
GPIO14	--	--	--	--	--	GPIO14	GPIO14	--	--	--
GPIO15	--	--	--	--	--	GPIO15	GPIO15	--	--	--
GPIO16	--	--	--	GPIO16 / RXD1 / MOSI	GPIO16 / RXD1 / MOSI	GPIO16 / AP_WAKEUP / RXD1 / MOSI	GPIO16 / RXD1 / MOSI	GPIO16 / RXD1	GPIO16 / RXD1	GPIO16 / RXD1 / MOSI (rel.1 only)
GPIO17	--	--	--	GPIO17 / TXD1 / MISO	GPIO17 / TXD1 / MISO	GPIO17 / HOST_ACTIVE / TXD1 / MISO	GPIO17 / TXD1 / MISO	GPIO17 / TXD1	GPIO17 / TXD1	GPIO17 / TXD1 / MISO (rel.1 only)
GPIO18	--	--	--	GPIO18 / RTS1 / SPI_CLK	GPIO18 / RTS1	GPIO18 / CP_WAKEUP / RTS1	GPIO18 / RTS1	GPIO18 / RTS1	GPIO18 / RTS1	GPIO18 / RTS1 / SPI_CLK (rel.1 only)
GPIO19	--	--	--	GPIO19 / CTS1 / SPI_CS	GPIO19 / CTS1 / SPI_CS	GPIO19 / CTS1 / SPI_CS	GPIO19 / CTS1 / SPI_CS	GPIO19 / CTS1	GPIO19 / CTS1	GPIO19 / CTS1 / SPI_CS (rel.1 only)
GPIO20	--	--	--	GPIO20 / TXDDAI	GPIO20 / TXDDAI	GPIO20 / TXDDAI	GPIO20 / TXDDAI	GPIO20 / TXDDAI	GPIO20	--
GPIO21	--	--	--	GPIO21 / RXDDAI	GPIO21 / RXDDAI	GPIO21 / RXDDAI	GPIO21 / RXDDAI	GPIO21 / RXDDAI	GPIO21	--
GPIO22	--	--	--	GPIO22 / TFSDAI	GPIO22 / TFSDAI	GPIO22 / TFSDAI	GPIO22 / TFSDAI	GPIO22 / TFSDAI	GPIO22	--
GPIO23	--	--	--	GPIO23 / SCLK	GPIO23 / SCLK	GPIO23 / SCLK	GPIO23 / SCLK	GPO23 / SCLK	GPIO23	--
GPIO24	--	--	--	GPIO24 / RING0	GPIO24 / RING0	GPIO24 / RING0	GPIO24 / RING0	GPIO24 / RING0	GPIO24 / RING0	GPIO24 / RING0
GPIO25	--	--	--	--	--	--	--	GPIO25	GPIO25	--
GPIO26	--	--	--	--	--	--	--	GPO26 / SPI_CS1	GPO26 / SPI_CS1	--
GPIO27	--	--	--	--	--	--	--	GPIO27 / SPI_CS2	GPIO27 / SPI_CS2	--

Notes:

- With ELS31 the DAI interface is only hardware prepared, i.e., with the current firmware releases not useable as such. This means that for the time being GPIO20-23 cannot be configured as DAI signals in the same way as EHS6 or EHS8. ELS31-VA supports DAI interface.
- With ELS61 and ELS81 the HSIC interface is only hardware prepared, i.e., with the current firmware releases not useable as such. This means that for the time being GPIO16-18 cannot be configured as HSIC control signals in the same way as for EHS6 or EHS8. Also, the GPIO20-23 lines can be configured as DAI interface only for ELS61-E R2 and ELS61-USA.

Table 30: GPIO start-up/reset signal states

GPIO lines	BGS1	BGS12	BGS2	BGS5	EHS5	EHS6, EHS8	ELS61, ELS81	ELS31	EMS31	Cinterion® ENS22
GPIO1	T / 60k PU (rel.1)	(DTR0)	(DTR0)	T / PD	T / PD	T / PD	T / PD	T	I / PU	T / No pull
GPIO2	T / 60k PU (rel.1)	(DCD0)	(DCD0)	T / PD	T / PD	T / PD	T / PD	T	I	T / No pull
GPIO3	T / 60k PU (rel.1)	(DSR0)	(DSR0)	T / PU	T / PD	T / PD	T / PD	T	I	T / No pull
GPIO4	T / 60k PU (rel.1) T/10K PU (FST_SHDN)	(FST_SHDN)	(FST_SHDN)	T / PD	T / PD	T / PD	T / PD	T / PD	I	T / No pull
GPIO5	T / 60K PU	O / L	T / PU -102µA at 0V	T / PD	T / PD	T / PD	T / PD	T / PD (GPO5)	I	T / No pull
GPIO6	T / 60K PU	I / 166k PD	T / PU -55µA at 0V	T / PD	T / PD	T / PD	L	T	I / PU	--
GPIO7	T / 60K PD (rel.1) T / 60K PU (rel.2)	I / 166k PD	T / PU -55µA at 0V	T / PU	T / PD	T / PD	T / PD	T / PU	I / PU	--
GPIO8	T / 60K PU	I / 166k PD	T / PU -55µA at 0V	T / PU	T / PD	T / PD	T / PD	T	I	T / No pull
GPIO9	T / 60k PD	O / L	T / 5k PU	T / PD	T / PD	T / PD	T / PD	T / PD	--	T / No pull

GPIO lines	BGS1	BGS12	BGS2	BGS5	EHS5	EHS6, EHS8	ELS61, ELS81	ELS31	EMS31	Cinterion® ENS22
GPIO10	I / 60k PD	O / L	T	T / PD	T / PD	T / PD	T / PD	T / PD	--	T / No pull
GPIO11	--		--	--	--	T / PD	T / PD	--	--	--
GPIO12	--		--	--	--	T / PD	T / PD	--	--	--
GPIO13	--		--	--	--	T / PD	T / PD	--	--	--
GPIO14	--		--	--	--	T / PD	T / PD	--	--	--
GPIO15	--		--	--	--	T / PD	T / PD	--	--	--
GPIO16	--		--	T / PD	T / PD	T / PD	T / PU	T	I / PU	T / No pull
GPIO17	--		--	T / PD	T / PD	T / PD	T / PD	T / PU	I / PU	T / No pull
GPIO18	--		--	T / PU	T / PD	T / PD	T / PU	T / PU	I / PU	T / No pull
GPIO19	--		--	T / PD	T / PD	T / PD	T / PU	T / PU	I / PU	T / No pull
GPIO20	--		--	T / PD	T / PD	T / PD	T / PD	T	I / PU	--
GPIO21	--		--	T / PD	T / PD	T / PD	T / PD	T	I / PU	--
GPIO22	--		--	T / PD	T / PD	T / PD	T / PD	T	I / PU	--
GPIO23	--		--	T / PD	T / PD	T / PD	T / PD	T (GPO23)	I / PU	--
GPIO24	--		--	T / PU	T / PD	T / PD	T / PD	T	I	T / No pull
GPIO25	--		--	--	--	--	--	T / PD	I	--
GPIO26	--		--	--	--	--	--	T (GPO26)	I / PU	--
GPIO27	--		--	--	--	--	--	T	I / PU	--

For more information on the interface and its start-up timings please refer to the respective “Hardware Interface Description”.

3.3.21 ADC1

Table 31: ADC1 characteristics

ADC1 ²⁷	BGS1	BGS2	BGS5	EHS5, EHS6, EHS8	ELS61, ELS81	ELS31	EMS31	EXS82	Cinterion® ENS22 BGS12
Resolution	10 Bit	10 Bit	10 Bit	10 Bit	10 Bit	10 Bit	10 Bit	15 Bit	Not supported
R _I	1MΩ	1MΩ	1MΩ	1MΩ	1MΩ	10kΩ	10kΩ	1MΩ	
Valid range	0V ... 1.2V	0V ... 1.2V	0V ... 1.14V	0V ... 1.2V	0V ... 1.2V	0V ... 2.0V	0V ... 2.0V	0.1V ... 1.7V	
V _{IHmax}	3.0V	3.3V	1.14V	1.2V	1.2V	2V	1.8V	1.75V	

For more information on the ADC1 line please refer to the respective “Hardware Interface Description”.

²⁷ Please note that the ADC1 signal is not supported with EHS5 Release 1.

3.3.22 Fast Shutdown

BGS1, BGS12, BGS2, BGS5, EHSx, ELSx, EMS31, and EXS82 support a FST_SHDN signal²⁸. If enabled by AT command, a low impulse >10ms on the FST_SHDN line starts the fast shutdown. The fast shutdown procedure still finishes any data activities on the module's flash file system, thus ensuring data integrity, but will no longer deregister gracefully from the network, thus saving the time required for network deregistration.

Note: With ELS61 and ELS81, a shutdown triggered by AT^SMSO can be configured by AT command either as a normal or as a fast shutdown. With BGS1, BGS12, BGS2, BGS5, EHSx, ELS31, and EMS31 no such configuration is available. If fast shutdown is enabled by AT command, the AT^SMSO command triggers a fast shutdown, i.e., a shutdown without network deregistration. However, in this case no URCs including shutdown URCs will be provided by the AT^SMSO command.

Table 32: FST_SHDN characteristics

FST_SHDN	BGS1	BGS12	BGS2	BGS5	EHS5, EHS6, EHS8	ELS61, ELS81	ELS31	EMS31	EXS82	Cinterion® ENS22
V _{IH} max	1.9V	3.1V	1.9V	1.85V	1.85V	1.85V	1.8V	1.8V	TBD.	Not supported
V _{IH} min	1.30V	1.96V	1.35V	1.3V	1.3V	1.3V	1.17V	1.17V	TBD.	
V _{IL} max	0.34V I _{IH} min < - 200µA at V _{IH} min	0.84V	0.34V I _{IH} min < - 200µA at V _{IH} min	0.35V I _{IH} min < -105µA at V _{IH} min	0.35V I _{IH} min < -200µA at V _{IH} min	0.35V I _{IH} min < -200µA at V _{IH} min	0.63V	0.63V	TBD.	
Shutdown time	95ms	10ms	50ms	15ms	120ms	15ms	200ms	15ms	15ms	
FST_SHDN charges	33mAs	5mAs	11mAs	8.5mAs	12mAs	13mAs	162mAs	11mAs	TBD.	

For more information on the fast shutdown line please refer to the respective “Hardware Interface Description” and “AT Command Set”.

²⁸ Please note that the fast shutdown signal is not supported with EHS5 Release 1.

3.4 Antenna Interface

3.4.1 RF Antenna

The BGS5, EHSx, ELSx, and EMS31 antenna interfaces have no internal ESD protection implemented. It is recommended to add an external ESD protection, an example is given in Figure 7. The additional components should be placed as close as possible to the antenna pad.

The BGS1, BGS12, BGS2, Cinterion® ENS22, and EXS82 antenna interfaces have an internal ESD protection implemented. For compatibility reasons and a possible migration however, it is advised to envisage the recommended possible ESD protection circuits (T pad or PI pad) in external applications currently using BGS2 modules (see Figure 8). The placement options may then later be activated if required.

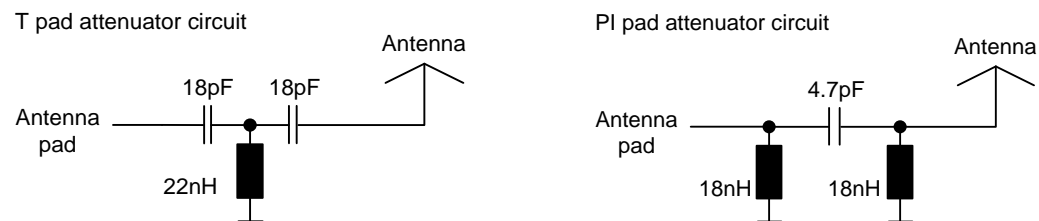

Figure 7: Possible BGS5, EHSx, ELSx, and EMS31 ESD protection circuits - T or PI pad

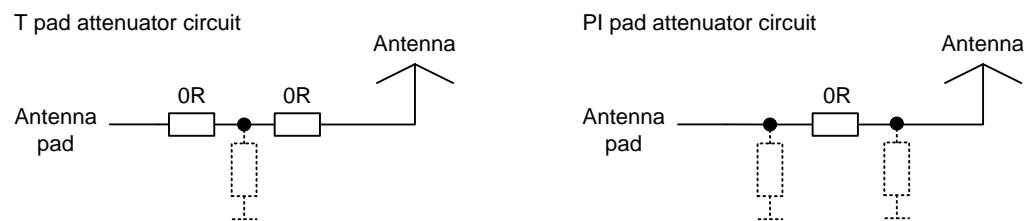

Figure 8: Possible designated ESD protection circuit - T or PI pad

Table 33: ESD protection on external application

RF antenna	BGS1 BGS12	BGS2	BGS5	EHS5, EHS6, EHS8	ELS61, ELS81	ELS31	EMS31	Cinterion® ENS22	EXS82
Internal ESD protection	Supported	Supported	Not supported	Not supported	Not supported	Not supported	Not supported	Supported	Supported
Inductors: 22nH (T pad) or 18nH (PI pad)	Not placed	Not placed	Yes	Yes	Yes	Yes	Yes	Not placed	Not placed
Capacitors: 18pF (T pad) or 4.7pF (PI pad)	0 Ohm	0 Ohm	Yes	Yes	Yes	Yes	Yes	0 Ohm	0 Ohm

Possible inductors: Murata LQG15HS22NJ02D (22nH), and LQW15AN18NJ00 (18nH)

For more information on the RF antenna interface please refer to the respective “Hardware Interface Description”.

3.4.2 GNSS Antenna

EHS8 and EXS82 have a GNSS receiver implemented. The GNSS antenna installation is the same as for the RF antenna interface, except for pad 224 (for EHS8) or pad 56 (for EXS82) instead of pad 59, and described in the EHS8/EXS82 “Hardware Interface Description”.

Table 34: GNSS antenna

	BGS1, BGS12, BGS2, BGS5, EHS5, EHS6, ELS61, ELS81, ELS31, EMS31, Cinterion® ENS22	EHS8, EXS82
GPS	Not supported	Supported

With EHS8 an external active GNSS antenna can be supplied via a dedicated ANT_GPS_PWR pad.

For more information on GNSS please refer to the EHS8/EXS82 “Hardware Interface Description”.

3.4.3 Rx Diversity Antenna

ELS31, ELS61 and ELS81 support an Rx diversity antenna at pad 56. The Rx diversity antenna is a receiving antenna, and as such does not transmit any RF output power.

Table 35: Rx diversity antenna

	BGS1, BGS12, BGS2, BGS5, EHS5, EHS6, EHS8, EMS31, Cinterion® ENS22, EXS82	ELS31, ELS61, ELS81
Rx diversity	Not supported	Supported

Note: For approval reasons it is mandatory to connect/use this Rx diversity antenna to an existing antenna. Not connecting/using the Rx diversity antenna does not necessarily impact the performance, but may result in approval failures.

For more information on Rx diversity please refer to the respective "Hardware Interface Description".





4 Common Footprint Design

To support a possible common footprint design, this chapter assembles the pad layout and assignment for all Gemalto M2M modules mentioned in this document – BGS1, BGS12, BGS2, BGS5, Cinterion® ENS22, EHS5, EHS6, EHS8, ELS31, EMS31, ELS61, and ELS81, thereby showing the differences between the modules. The pad layout differences will also have to be taken into account for the stencil design. For SMT PCB assembly and recommended stencil designs please refer to the respective “Hardware Interface Description”. For a combined land pattern, please see Section 4.1.

The below Figure 9 illustrates a common footprint for the below mentioned various pad layouts:

Module	Dimensions	Pad count	LGA number
BGS1, BGS2, EHS5, Cinterion® ENS22	27.6 x 18.8	106	LGA106
BGS12, BGS5, ELS31, EMS31, EXS82		114	LGA114
EHS6, EHS8, ELS61, ELS81	27.6 x 25.4	120	LGA120

Because of the different module dimensions and pad layouts some pads in the given common footprint are not available for all modules:

- Pads lined black  are available for all modules.
- Pads lined red  are available for BGS1, BGS2, BGS5, Cinterion® ENS22, EHS5, ELS31, EMS31, EXS82 only
- Pads lined orange  are available for BGS12, BGS5, EHS6, EHS8, ELS31, ELS61, ELS81, EMS31 and EXS82 only
- Pads lined grey  are available for EHS6, EHS8, ELS61, and ELS81 only

In addition, the comprehensive Table 34 lists the pad assignments for all modules, and differentiates between products with a pad count of 106 (LGA106), 114 (LGA114) and 120 (LGA120). Pads having the same functionality assigned with all modules are listed in grey. Pads varying in functionality between modules are listed in black.

With regard to pad assignment a few notes should be considered for a common footprint design:

- Pads labeled "--*", i.e., do not use, must be left un-connected at the external application, but should be soldered.
- Pads labeled "nc", i.e., not connected, indicate that a pad is not electrically connected on the module. For a common footprint this means that only a possible other functionality with a different module may be implemented for this pad, without having to take a transition from one pad assignment to another into account.
- BGS1 and BGS2 pads VDIG and V180 shall be connected in all cases. See also Section 3.3.5 for more detail.
- To activate or deactivate module specific functions for smooth transition, the appropriate pads should be connected via 0 Ohm resistors or assembling options. For example, the VUSB assignment at pad 44 is listed in black, indicating a pad that should be connected via 0 Ohm resistors to easily activate or deactivate the pad's USB functionality for the appropriate module. The pad's other "--*" (do not use) functionality may also be connected via 0 Ohm resistors to be able to activate or deactivate it for another module. However, in this sample case the "--*" functionality may also be left unconnected.
- Pads available for BGS1, BGS12, BGS2, BGS5, Cinterion® ENS22, EHS5, ELS31, EMS31 and EXS82 only, and pads available for EHS6, EHS8, ELS61 and ELS81 only should be connected where possible, i.e., as far as these pads are assigned to the same signals.
- Pad assignments given in brackets are software configurable after module startup.

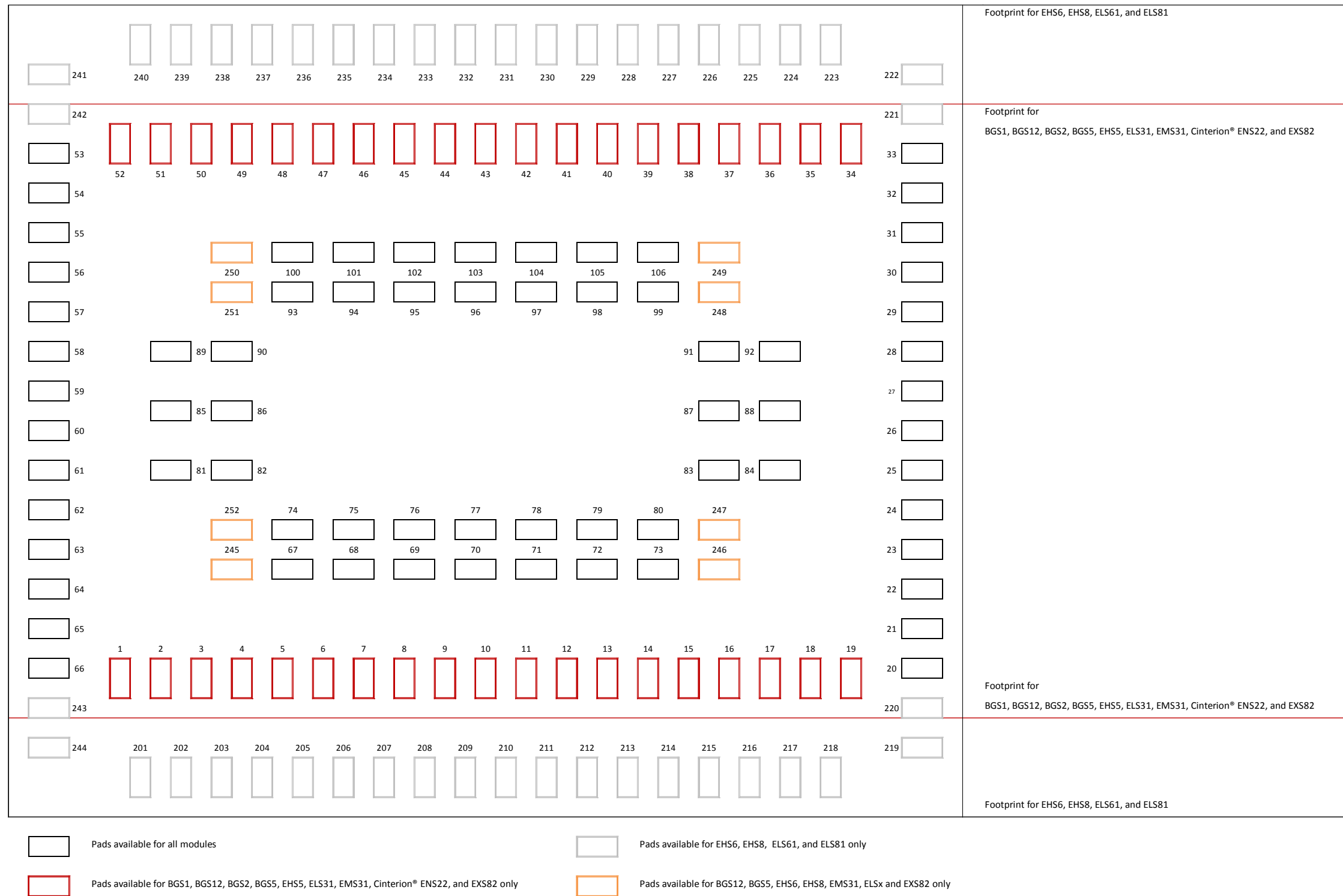

Figure 9: Common footprint for BGSx, EHSx, ELSx, EMS31, Cinterion® ENS22, and EXS82 (bottom view)

Table 36: Pad assignments for BGSx, EHSx, ELSx, EMS31, Cinterion® ENS22, and EXS82

Pad # LGA106	BGS1 LGA106	BGS2 LGA106	EHS5 LGA106	ENS22 LGA106	Pad # LGA114	BGS12 LGA114	BGS5 LGA114	ELS31 LGA114	EMS31 LGA114	EXS82 LGA114	Pad # LGA120	EHS6 LGA120	EHS6-A LGA120	EHS8 LGA120	ELS61, ELS81 LGA120
Outer pads															
1	VMIC	VMIC	---*	nc	1	VMIC	VMIC ²⁹	GND	GND	---*	---				
2	EPN	EPN	---*	nc	2	EPN	EPN ²⁹	GND	GND	SUSPEND_MON	201	---*	EPN	---*	nc
3	EPP	EPP	---*	nc	3	EPP	EPP ²⁹	GND	GND	---*	202	---*	EPP	---*	nc
4	GND	GND	GND	GND	4	GND	GND	GND	GND	GND	203	GND	GND	GND	GND
5	BATT+ _{BB}	BATT+ _{BB}	BATT+ _{BB}	BATT+ _{BB}	5	BATT+ _{BB}	BATT+	BATT_RF	BATT+	BATT+ _{BB}	204	BATT+ _{BB}	BATT+ _{BB}	BATT+ _{BB}	BATT+ _{BB}
6	GND	GND	GND	GND	6	GND	GND	GND	GND	GND	205	GND	GND	GND	GND
7	ADC1	ADC1_IN	ADC1	nc	7	nc	ADC1	ADC1	ADC1	ADC1	206	ADC1	ADC1	ADC1	ADC1
8	ON	ON	ON	ON	8	ON	ON	ON	ON	ON	207	ON	ON	ON	ON
9	GND	GND	GND	GND	9	GND	GND	GND	GND	GND	208	GND	GND	GND	GND
10	VDIG	VDIG	V180	V300	10	V280	V180	V180	V180	V180	209	V180	V180	V180	V180
11	RXD0	RXD0	RXD0	RXD0	11	RXD0	RXD0	RXD0	RXD0	RXD0	210	RXD0	RXD0	RXD0	RXD0
12	CTS0	CTS0	CTS0	CTS0	12	CTS0	CTS0	CTS0	CTS0	CTS0	211	CTS0	CTS0	CTS0	CTS0
13	TXD0	TXD0	TXD0	TXD0	13	TXD0	TXD0	TXD0	TXD0	TXD0	212	TXD0	TXD0	TXD0	TXD0
14	RING0	RING0	GPIO24 (RING0)	GPIO24 (RING0)	14	RING0	GPIO24 (RING0)	GPIO24 (RING0)	GPIO24 (RING0)	RING0	213	GPIO24 (RING0)	GPIO24 (RING0)	GPIO24 (RING0)	GPIO24 (RING0)
15	RTS0	RTS0	RTS0	RTS0	15	RTS0	RTS0	RTS0	RTS0	RTS0	214	RTS0	RTS0	RTS0	RTS0
16	VDDL	VDDL	VDDL	nc	16	VDDL	VDDL	nc	nc	nc	215	VDDL	VDDL	VDDL	VDDL
17	CCRST	CCRST	CCRST	CCRST	17	CCRST	CCRST	CCRST	CCRST	CCRST	216	CCRST	CCRST	CCRST	CCRST
18	CCIN	CCIN	CCIN	---*	18	CCIN	CCIN	CCIN	CCIN	CCIN	217	CCIN	CCIN	CCIN	CCIN
19	CCIO	CCIO	CCIO	CCIO	19	CCIO	CCIO	CCIO	CCIO	CCIO	218	CCIO	CCIO	CCIO	CCIO
											219	GPIO14		GPIO14	GPIO14
											220	GPIO13		GPIO13	GPIO13
20	CCVCC	CCVCC	CCVCC	CCVCC	20	CCVCC	CCVCC	CCVCC	CCVCC	CCVCC	20	CCVCC	CCVCC	CCVCC	CCVCC
21	CCCLK	CCCLK	CCCLK	CCCLK	21	CCCLK	CCCLK	CCCLK	CCCLK	CCCLK	21	CCCLK	CCCLK	CCCLK	CCCLK
22	V285	V285	VCORE	nc	22	nc	VCORE	VCORE	VCORE	VCORE	22	VCORE	VCORE	VCORE	VCORE
23	--	TXDDAI	GPIO20 (TXDDAI)	nc	23	---*	GPIO20 (TXDDAI)	GPIO20 (TXDDAI) ³⁰	GPIO20	---*	23	GPIO20 (TXDDAI)	GPIO20 (TXDDAI)	GPIO20 (TXDDAI)	GPIO20 (TXDDAI) ³⁰
24	Do not use	TFSDAI	GPIO22 (TFSDAI)	nc	24	---*	GPIO22 (TFSDAI)	GPIO22 (TFSDAI) ³⁰	GPIO22	---*	24	GPIO22 (TFSDAI)	GPIO22 (TFSDAI)	GPIO22 (TFSDAI)	GPIO22 (TFSDAI) ³⁰
25	Do not use	RXDDAI	GPIO21 (RXDDAI)	nc	25	---*	GPIO21 (RXDDAI)	GPIO21 (RXDDAI) ³⁰	GPIO21	---*	25	GPIO21 (RXDDAI)	GPIO21 (RXDDAI)	GPIO21 (RXDDAI)	GPIO21 (RXDDAI) ³⁰
26	Do not use	SCLK	GPIO23 (SCLK)	nc	26	---*	GPIO23 (SCLK)	GPIO23 (SCLK) ³⁰	GPIO23	---*	26	GPIO23 (SCLK)	GPIO23 (SCLK)	GPIO23 (SCLK)	GPIO23 (SCLK) ³⁰
27	GPIO10 I2CDAT	GPIO10 I2CDAT	I2CDAT	GPIO10 I2CDAT ³⁰	27	GPIO10 I2CDAT	I2CDAT	I2CDAT	I2CDAT	---*	27	I2CDAT	I2CDAT	I2CDAT	I2CDAT
28	GPIO9 I2CCLK	GPIO9 I2CCLK	I2CCLK	GPIO9 I2CCLK ³⁰	28	GPIO9 I2CCLK	I2CCLK	I2CCLK	I2CCLK	---*	28	I2CCLK	I2CCLK	I2CCLK	I2CCLK
29	TXD1	TXD1	GPIO17 (TXD1) (MISO)	GPIO17 (TXD1) (MISO) ³⁰	29	TXD1	(GPIO17) TXD1 (MISO)	GPIO17 (HOST_ACTIVE) ³⁰ (TXD1)	GPIO17		29	GPIO17 (HOST_ACTIVE) (TXD1) (MISO)	GPIO17 (HOST_ACTIVE) (TXD1) (MISO)	GPIO17 (HOST_ACTIVE) (TXD1) (MISO)	GPIO17 (HOST_ACTIVE) ³⁰ (TXD1) (MISO)
30	RXD1	RXD1	GPIO16 (RXD1) (MOSI)	GPIO16 (RXD1) (MOSI) ³⁰	30	RXD1	(GPIO16) RXD1 (MOSI)	GPIO16 (AP_WAKEUP) ³⁰ (RXD1)	GPIO16		30	GPIO16 (AP_WAKEUP) (RXD1) (MOSI)	GPIO16 (AP_WAKEUP) (RXD1) (MOSI)	GPIO16 (AP_WAKEUP) (RXD1) (MOSI)	GPIO16 (AP_WAKEUP) ³⁰ (RXD1) (MOSI)

²⁹ Do not use. Hardware prepared for future use as analog audio interface.

³⁰ Notes:

- With ELS31 the DAI interface is only hardware prepared, i.e., with the current firmware releases not useable as such. This means that for the time being GPIO20-23 cannot be configured as DAI signals in the same way as EHS6 or EHS8.
- With ELS61 and ELS81 the DAI interface lines GPIO20-23 are only available for the product variants ELS61-E R2 and ELS61-USA.
- With ELS61 the HSIC interface is only hardware prepared, i.e., with the current firmware releases not useable as such. This means that for the time being GPIO16-18 cannot be configured as HSIC control signals in the same way as EHS6 or EHS8. Also, with ELS61 and ELS81, the HSIC_DATA and HSIC_STRB lines (pads #236, #237) are currently not useable.
- With Cinterion® ENS22-E as of Release 1.1 the I²C and SPI interfaces are no longer supported.

Pad # LGA106	BGS1 LGA106	BGS2 LGA106	EHS5 LGA106	ENS22 LGA106	Pad # LGA114	BGS12 LGA114	BGS5 LGA114	ELS31 LGA114	EMS31 LGA114	EXS82 LGA114	Pad # LGA120	EHS6 LGA120	EHS6-A LGA120	EHS8 LGA120	ELS61, ELS81 LGA120
31	RTS1	RTS1	GPIO18 (RTS1)	GPIO18 (RTS1) (SPI_CLK) ³⁰	31	nc	(GPIO18) RTS1 (SPI_CLK)	GPIO18 (CP_WAKEUP) ³⁰ (RTS1)	GPIO18 (RTS1)	RTS1	31	GPIO18 (CP_WAKEUP) (RTS1)	GPIO18 (CP_WAKEUP) (RTS1)	GPIO18 (CP_WAKEUP) (RTS1)	GPIO18 (CP_WAKEUP) ³⁰ (RTS1)
32	CTS1	CTS1	(CTS1) (SPI_CS)	GPIO19 (CTS1) (SPI_CS) ³⁰	32	nc	(GPIO19) CTS1 (SPI_CS)	GPIO19 (SUSPEND) ³⁰ (CTS1)	GPIO19 (CTS1)	CTS1	32	GPIO19 (SUSPEND) (CTS1) (SPI_CS)	GPIO19 (SUSPEND) (CTS1) (SPI_CS)	GPIO19 (SUSPEND) (CTS1) (SPI_CS)	GPIO19 (SUSPEND) ³⁰ (CTS1) (SPI_CS)
33	EMERG_RST	EMERG_RST	EMERG_RST	EMERG_RST	33	EMERG_OFF	EMERG_RST	EMERG_RST	EMERG_RST	EMERG_RST	33	EMERG_RST	EMERG_RST	EMERG_RST	EMERG_RST
											221	GPIO12	GPIO12	GPIO12	GPIO12
											222	GPIO11	GPIO11	GPIO11	GPIO11
34	GND	GND	GND	GND	34	GND	GND	GND	GND	GND	223	GND	GND	GND	GND
35	V180	V180	nc	--*	35	nc	--*	GPIO25	GPIO25	nc	224	--*	--*	ANT_GPS	--*
36	GPIO8	GPIO8	GPIO8 (COUNTER)	GPIO8	36	GPIO8	GPIO8 (COUNTER)	GPIO8 (COUNTER)	GPIO8 (COUNTER)	SIM_SWITCH	225	GND	GND	GND	GND
37	GPIO7	GPIO7 (PWM1)	GPIO7 (PWM1)	nc	37	GPIO7	GPIO7 (PWM1)	GPIO7	GPIO7 (PWM1)	--*	226	--*	--*	--*	--*
38	GPIO6 (PWM2) (Jamming Ind)	GPIO6 (PWM2)	GPIO6 (PWM2)	nc	38	GPIO6 (Jamming Ind.)	GPIO6 (PWM2)	GPIO6	GPIO6 (PWM2)	--*	227	GND	GND	GND	GND
39	GPIO5 (LED)	GPIO5 (LED)	GPIO5 (LED)	GPIO5	39	GPIO5 (LED)	GPIO5 (LED)	GPO5 (LED)	GPIO5 (LED)	STATUS	228	--*	--*	ANT_GPS_PWR	--*
40	FAST_SHTDWN	(FST_SHDN)	GPIO4 (FST_SHDN)	GPIO4	40	FAST_SHTDWN	GPIO4 (FST_SHDN)	GPIO4 (FST_SHDN)	GPIO4 (FST_SHDN)	FST_SHDN	229	GPIO4 (FST_SHDN)	GPIO4 (FST_SHDN)	GPIO4 (FST_SHDN)	GPIO4 (FST_SHDN)
41	DSR0	DSR0	GPIO3 (DSR0) (SPI_CLK)	GPIO3 (DSR0)	41	DSR0	(GPIO3) DSR0	GPIO3 (DSR0)	GPIO3 (DSR0)	DSR0	230	GPIO3 (DSR0) (SPI_CLK)	GPIO3 (DSR0) (SPI_CLK)	GPIO3 (DSR0) (SPI_CLK)	GPIO3 (DSR0) (SPI_CLK)
42	DCD0	DCD0	GPIO2 (DCD0)	GPIO2 (DCD0)	42	DCD0	(GPIO2) DCD0	GPIO2 (DCD0)	GPIO2 (DCD0)	DCD0	231	GPIO2 (DCD0)	GPIO2 (DCD0)	GPIO2 (DCD0)	GPIO2 (DCD0)
43	DTR0	DTR0	GPIO1 (DTR0)	GPIO1 (DTR0)	43	DTR0	(GPIO1) DTR0	GPIO1 (DTR0)	GPIO1 (DTR0)	DTR0	232	GPIO1 (DTR0)	GPIO1 (DTR0)	GPIO1 (DTR0)	GPIO1 (DTR0)
44	GND	GND	VUSB	nc	44	nc	VUSB	VUSB	nc	VUSB	233	VUSB	VUSB	VUSB	VUSB
45	GND	GND	USB_DP	nc	45	nc	USB_DP	USB_DP	nc	USB_DP	234	USB_DP	USB_DP	USB_DP	USB_DP
46	GND	GND	USB_DN	nc	46	nc	USB_DN	USB_DN	nc	USB_DN	235	USB_DN	USB_DN	USB_DN	USB_DN
47	GND	GND	GND	GND	47	GND	GND	GND	GND	GND	236	HSIC_DATA	HSIC_DATA	HSIC_DATA	HSIC_DATA ³⁰
48	GND	GND	GND	GND	48	GND	GND	GND	--*	GND	237	HSIC_STRB	HSIC_STRB	HSIC_STRB	HSIC_STRB ³⁰
49	GND	GND	GND	GND	49	GND	GND	GND	GND	GND	238	GND	GND	GND	GND
50	GND	GND	GND	GND	50	GND	GND	GND	GND	GND	239	GPIO5 (LED)	GPIO5 (LED)	GPIO5 (LED)	GPIO5 (LED)
51	GND	GND	GND	GND	51	GND	GND	GND	GND	GND	240	GPIO6 (PWM2)	GPIO6 (PWM2)	GPIO6 (PWM2)	GPIO6 (PWM2)
52	GND	GND	GND	GND	52	GND	GND	GND	GND	GND	---				
											241	GPIO7 (PWM1)	GPIO7 (PWM1)	GPIO7 (PWM1)	GPIO7 (PWM1)
											242	GPIO8 (COUNTER)	GPIO8 (COUNTER)	GPIO8 (COUNTER)	GPIO8 (COUNTER)
53	BATT+RF	BATT+RF	BATT+RF	BATT+RF	53	BATT+RF	BATT+	BATT+BB	BATT+	BATT+RF	53	BATT+RF	BATT+RF	BATT+RF	BATT+RF
54	GND	GND	GND	GND	54	GND	GND	GND	GND	GND	54	GND	GND	GND	GND
55	GND	GND	GND	GND	55	GND	GND	GND	GND	GND	55	GND	GND	GND	GND
56	GND	GND	GND	GND	56	GND	GND	DIV_ANT	nc	GNSS_ANT	56	GND	GND	GND	ANT_DRX
57	GND	GND	GND	GND	57	GND	GND	GND	GND	GND	57	GND	GND	GND	GND
58	GND	GND	GND	GND	58	GND	GND	GND	GND	GND	58	GND	GND	GND	GND
59 ³¹	RF_OUT	ANT_GSM	RF_OUT	RF_OUT	59	RF_OUT	RF_OUT	RF_OUT	RF_OUT	RF_OUT	59	ANT_GSM	ANT_GSM	ANT_GSM	ANT_MAIN
60	GND	GND	GND	GND	60	GND	GND	GND	GND	GND	60	GND	GND	GND	GND

³¹ ANT_GSM, RF_OUT and ANT_MAIN all identify the main RF antenna pad, whereas DIV_ANT and ANT_DRX signify the Rx diversity antenna pad.

Pad # LGA106	BGS1 LGA106	BGS2 LGA106	EHS5 LGA106	ENS22 LGA106	Pad # LGA114	BGS12 LGA114	BGS5 LGA114	ELS31 LGA114	EMS31 LGA114	EXS82 LGA114	Pad # LGA120	EHS6 LGA120	EHS6-A LGA120	EHS8 LGA120	ELS61, ELS81 LGA120
61	GND	GND	GND	GND	61	GND	GND	GND	GND	GND	61	GND	GND	GND	GND
62	GND	GND	GND	GND	62	GND	GND	GND	GND	GND	62	GND	GND	GND	GND
63	GND	GND	GND	GND	63	GND	GND	GND	GND	GND	63	GND	GND	GND	GND
64	AGND	AGND	--*	GND	64	GND	AGND ²⁹	GND	GND	GND	64	--*	AGND	--*	GND
65	MICP	MICP	--*	nc	65	MICP	MICP ²⁹	GPIO27 (SPI_CS2)	GPIO27 (SPI_CS2)	--*	65	--*	MICP	--*	--*
66	MICN	MICN	--*	nc	66	MICN	MICN ²⁹	GPO26 (SPI_CS1)	GPO26 (SPI_CS1)	--*	66	--*	MICN	--*	--*
											243	--*	VMIC	--*	--*
											244	GPIO15	GPIO15	GPIO15	GPIO15
Inner pads															
67	GND	GND	nc	GND	67	GND	--*	GND	GND	nc	67	--*	--*	--*	nc
68	GND	GND	nc	GND	68	GND	--*	GND	GND	nc	68	--*	--*	--*	nc
69	GND	GND	nc	GND	69	GND	--*	GND	GND	nc	69	--*	--*	--*	nc
70	GND	GND	nc	GND	70	GND	--*	GND	GND	nc	70	--*	--*	--*	nc
71	GND	GND	nc	GND	71	GND	--*	GND	GND	nc	71	--*	--*	--*	nc
72	GND	GND	nc	GND	72	GND	--*	nc	nc	nc	72	AUTO_ON	AUTO_ON	AUTO_ON	nc
73	GND	GND	nc	GND	73	GND	--*	GND	GND	nc	73	--*	--*	--*	nc
74	GND	GND	--*	GND	74	GND	--*	--*	--*	--*	74	nc	nc	nc	--*
75	GND	GND	--*	nc	75	GND	--*	--*	--*	--*	75	nc	nc	nc	--*
76	GND	GND	--*	nc	76	GND	--*	--*	--*	--*	76	nc	nc	nc	nc
77	GND	GND	--*	GND	77	GND	--*	--*	--*	--*	77	nc	nc	nc	nc
78	GND	GND	--*	GND	78	GND	--*	--*	--*	--*	78	nc	nc	nc	nc
79	GND	GND	AUTO_ON	GND	79	GND	--*	nc	nc	nc	79	nc	nc	nc	nc
80	GND	GND	--*	GND	80	GND	--*	nc	nc	nc	80	nc	nc	nc	nc
81	GND	GND	GND	GND	81	GND	GND	GND	GND	GND	81	GND	GND	GND	GND
82	GND	GND	GND	GND	82	GND	GND	GND	GND	GND	82	GND	GND	GND	GND
83	GND	GND	GND	GND	83	GND	GND	--*	nc	GND	83	GND	GND	GND	GND
84	GND	GND	GND	GND	84	GND	GND	GND	GND	GND	84	GND	GND	GND	GND
85	GND	GND	GND	GND	85	GND	GND	GND	GND	GND	85	GND	GND	GND	GND
86	GND	GND	GND	GND	86	GND	GND	GND	GND	GND	86	GND	GND	GND	GND
87	GND	GND	--*	GND	87	GND	--*	--*	nc	--*	87	--*	--*	--*	nc
88	GND	GND	GND	GND	88	GND	GND	GND	GND	GND	88	GND	GND	GND	GND
89	GND	GND	GND	GND	89	GND	GND	GND	GND	GND	89	GND	GND	GND	GND
90	GND	GND	GND	GND	90	GND	GND	GND	GND	GND	90	GND	GND	GND	GND
91	GND	GND	nc	GND	91	GND	--*	--*	--*	nc	91	nc	nc	nc	nc
92	GND	GND	GND	GND	92	GND	GND	GND	GND	GND	92	GND	GND	GND	GND
93	GND	GND	GND	GND	93	GND	GND	--*	CCIN2	GND	93	GND	GND	GND	GND
94	GND	GND	GND	GND	94	GND	GND	--*	CCCLK2	GND	94	GND	GND	GND	GND
95	GND	GND	GND	GND	95	GND	GND	--*	--*	GND	95	GND	GND	GND	GND
96	GND	GND	GND	GND	96	GND	GND	--*	CCIO2	GND	96	GND	GND	GND	GND
97	GND	GND	GND	GND	97	GND	GND	--*	CCVCC2	GND	97	GND	GND	GND	GND
98	TESTPIN	--*	--*	nc	98	nc	--*	GND	GND	GND	98	GND	GND	GND	GND
99	GND	GND	GND	GND	99	GND	GND	GND	GND	GND	99	GND	GND	GND	GND
100	GND	GND	GND	GND	100	GND	GND	GND	GND	GND	100	GND	GND	GND	GND
101	GND	GND	GND	GND	101	GND	GND	GND	GND	GND	101	GND	GND	GND	GND
102	GND	GND	GND	GND	102	GND	GND	GND	GND	GND	102	GND	GND	GND	GND
103	GND	GND	GND	GND	103	GND	GND	GND	GND	GND	103	GND	GND	GND	GND
104	GND	GND	GND	GND	104	GND	GND	nc	nc	GND	104	--*	--*	--*	--*
105	GND	GND	GND	GND	105	GND	GND	nc	nc	GND	105	--*	--*	--*	--*
106	GND	GND	GND	GND	106	GND	--*	SPI_MOSI	SPI_MOSI	--*	106	--*	--*	--*	--*

Pad # LGA106	BGS1 LGA106	BGS2 LGA106	EHS5 LGA106	ENS22 LGA106	Pad # LGA114	BGS12 LGA114	BGS5 LGA114	ELS31 LGA114	EMS31 LGA114	EXS82 LGA114	Pad # LGA120	EHS6 LGA120	EHS6-A LGA120	EHS8 LGA120	ELS61, ELS81 LGA120
					245	GND	GND	GND	GND	GND	245	GND	GND	GND	GND
					246	RTS2	--*	--	nc	--*	246	--*	--*	--*	nc
					247	CTS2	--*	--	nc	--*	247	--*	--*	--*	nc
					248	RXD2	--*	SPI_CLK	SPI_CLK	--*	248	--*	--*	--*	nc
					249	TXD2	--*	SPI_MISO	SPI_MISO	--*	249	--*	--*	--*	nc
					250	GND	GND	GND	GND	GND	250	GND	GND	GND	GND
					251	GND	GND	--	CCRST2	GND	251	GND	GND	GND	GND
					252	GND	GND	GND	GND	GND	252	GND	GND	GND	GND

Legend:

--*: Do not use, additional features for these pads may be hardware prepared

nc: internally not connected

4.2 Test Points

The below table lists mandatory signal test points that should be implemented for SMT applications (insofar as the module supports the corresponding interface lines) as well as further optional test points that might be implemented (insofar as the module employs the corresponding interface lines).

For details on test points and their implementation please refer to [3].

Table 37: Mandatory and optional test points for SMT applications

Test point	Required	Module
TP_PWR_IND	Yes	All
TP_IGT	Yes	All
TP_EMERG_RST or TP_EMERG_OFF (BGS12)	Yes	All
TP_V180	Yes	All except Cinterion® ENS22, BGS12
TP_V280	Yes	BGS12
TP_V300	Yes	Cinterion® ENS22
TP_V285	Yes	BGS2
TP_VCORE	Yes	BGS5, EHS5, EHS6, EHS8, ELS31, EMS31, ELS61, ELS81, and EXS82 only
TP_V285_VCORE	Yes	BGS2
TP_PAD91	Yes	ELS31, EMS31
TP_PAD87	Yes	ELS31, EMS31
TP_PAD83	Yes	ELS31, EMS31
TP_RXD0	Yes	All
TP_TXD0	Yes	All
TP_RTS0	Yes	All
TP_CTS0	Yes	All
TP_RXD1	Recommended	All
TP_TXD1	Recommended	All
TP_RTS1	Recommended	All except BGS12
TP_CTS1	Recommended	All except BGS12
TP_RXD2	Recommended	BGS12
TP_TXD2	Recommended	BGS12
TP_RTS2	Recommended	BGS12
TP_CTS2	Recommended	BGS12
TP_VBATT	Recommended	All

About Gemalto

Since 1996, Gemalto has been pioneering groundbreaking M2M and IoT products that keep our customers on the leading edge of innovation.

We work closely with global mobile network operators to ensure that Cinterion® modules evolve in sync with wireless networks, providing a seamless migration path to protect your IoT technology investment.

Cinterion products integrate seamlessly with Gemalto identity modules, security solutions and licensing and monetization solutions, to streamline development timelines and provide cost efficiencies that improve the bottom line.

As an experienced software provider, we help customers manage connectivity, security and quality of service for the long lifecycle of IoT solutions.

For more information please visit
www.gemalto.com/m2m, www.facebook.com/gemalto, or [Follow@gemaltoloT](https://twitter.com/Follow@gemaltoloT) on Twitter.

Gemalto M2M GmbH
Werinherstrasse 81
81541 Munich
Germany