

THIS DRAWING IS UNPUBLISHED. RELEASED FOR PUBLICATION  
 © COPYRIGHT BY TYCO ELECTRONICS CORPORATION. ALL RIGHTS RESERVED.

LOC	DIST	REVISIONS			
P	LTR	DESCRIPTION	DATE	DWN	APVD
AJ	16	A	REV PER ECO 06-002539	06APR06	GB JH

1. USE INSTRUCTION SHEET 408-1799-2.
2. FOR RG-142/U, 142A/U & 142B/U, USE CRIMP TOOL 69331-1. FOR RG-55/U, 55A/U & 55B/U, USE CRIMP TOOL 69140-2.

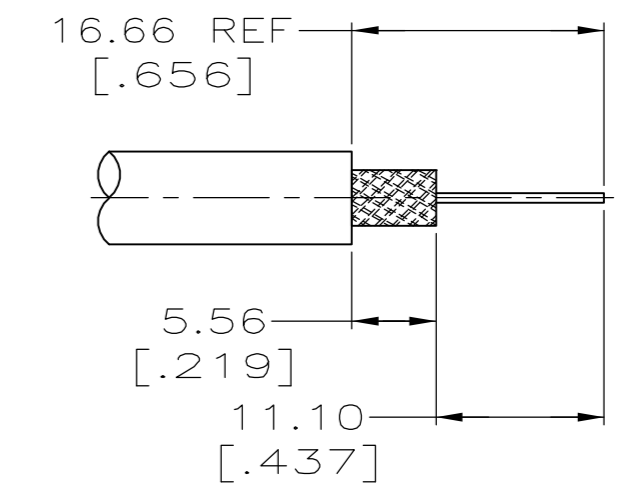
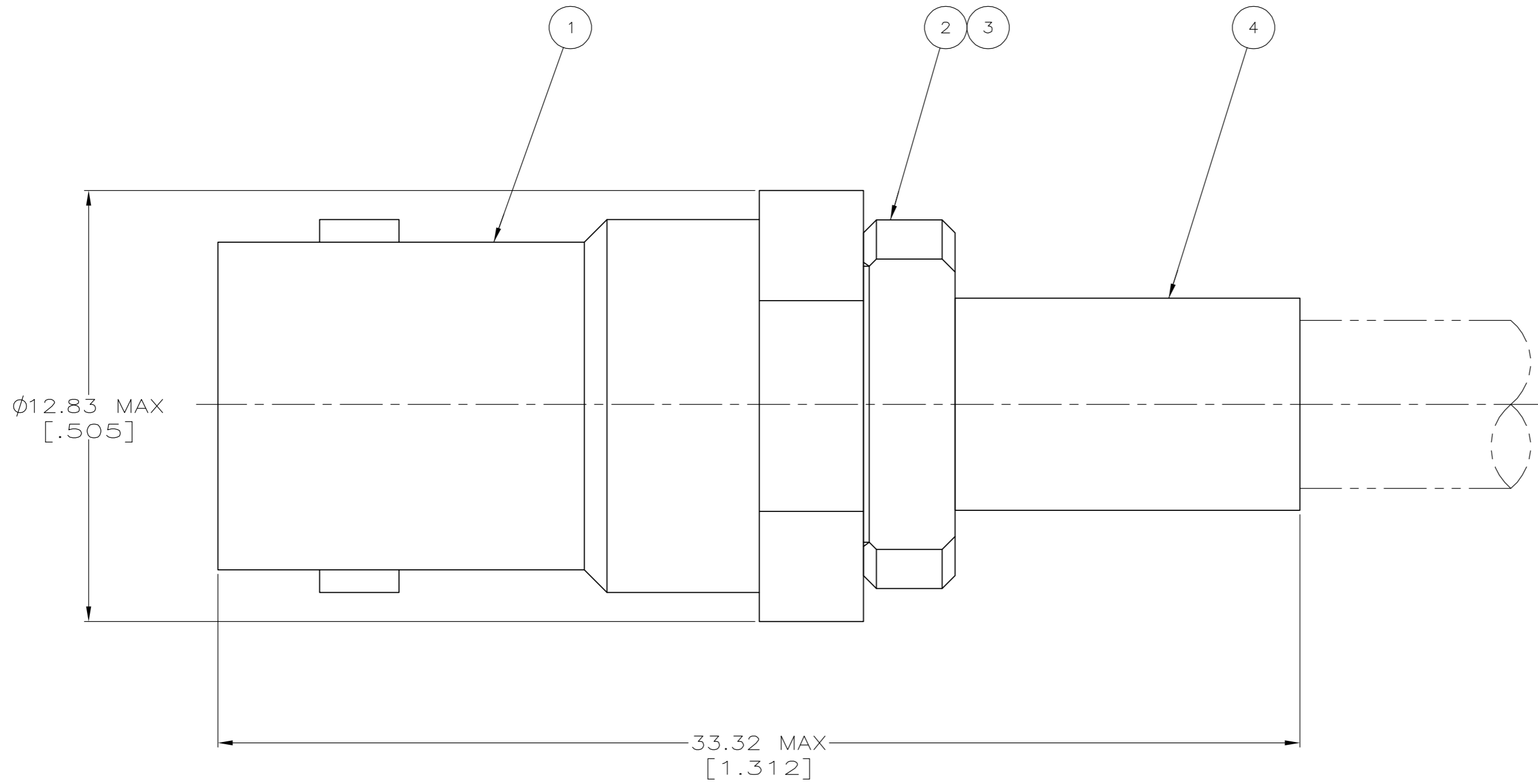

RECOMMENDED STRIP LENGTH  
SCALE 2:1

9-329099-2	9-50793-0	2-329106-1	9-329802-0	2-5329452-2
4 FERRULE QTY=1	3 CRIMP END ASSEMBLY QTY=1	2 GASKET QTY=1	1 JACK ASSEMBLY QTY=1	PART NUMBER

THIS DRAWING IS A CONTROLLED DOCUMENT.		DWN B. MCMASTER 10DEC05	Tyco Electronics Corporation Harrisburg, PA 17105-3608	
DIMENSIONS: mm [INCHES]		CHK J. LIPPERT 10DEC05	NAME JACK, BNC	
TOLERANCES UNLESS OTHERWISE SPECIFIED:		APVD J. LIPPERT 10DEC05	SIZE A2	
0 PLC ± -	1 PLC ± -	PRODUCT SPEC	CAGE CODE 00779	DRAWING NO C=5329452
2 PLC ± 0.41 [.016]	3 PLC ± -	APPLICATION SPEC	RESTRICTED TO	
4 PLC ± -	ANGLES ± -	WEIGHT	SCALE 8:1	SHEET 1 of 1
MATERIAL	FINISH	CUSTOMER DRAWING	REV A	