

THIS DRAWING IS UNPUBLISHED. RELEASED FOR PUBLICATION  
 © COPYRIGHT copyright\_date BY - ALL RIGHTS RESERVED.

REVISIONS					
P	LTR	DESCRIPTION	DATE	DWN	APVD
	G	HOUSING MATERIAL SUPPLIER CHANGE	03JAN2019	KJK	PS

POS. PER ROW 'N'	L	PART NUMBER	
2	5.08	215316-2	
3	7.62	-3	
4	10.16	-4	OBSOLETE
5	12.70	-5	
6	15.24	-6	
7	17.78	-7	
8	20.32	-8	OBSOLETE
9	22.86	-9	
10	25.40	1- -0	OBSOLETE
11	27.94	1- -1	
12	30.48	1- -2	OBSOLETE
13	33.02	1- -3	
14	35.56	1- -4	
15	38.10	1- -5	
16	40.64	1- -6	
17	43.18	1- -7	
18	45.72	1- -8	
19	48.26	1- -9	
20	50.80	2- -0	OBSOLETE
21	53.34	2- -1	
22	55.88	2- -2	
23	58.42	2- -3	
24	60.96	2- -4	
25	63.50	2- -5	
26	66.04	2- -6	OBSOLETE
27	68.58	2- -7	
28	71.12	2- -8	
29	73.66	2- -9	
30	76.20	3- -0	
31	78.74	3- -1	
32	81.28	3- -2	
33	83.82	3- -3	
34	86.36	3- -4	
35	88.90	3- -5	
36	91.44	3- 215316 -6	OBSOLETE

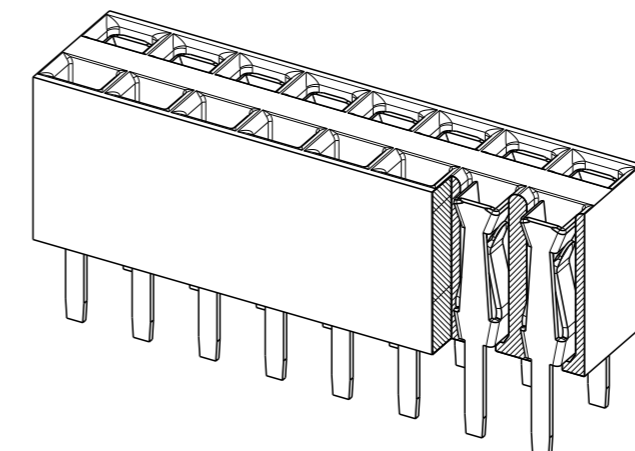
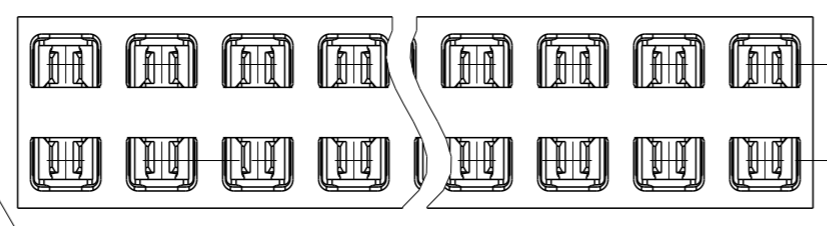
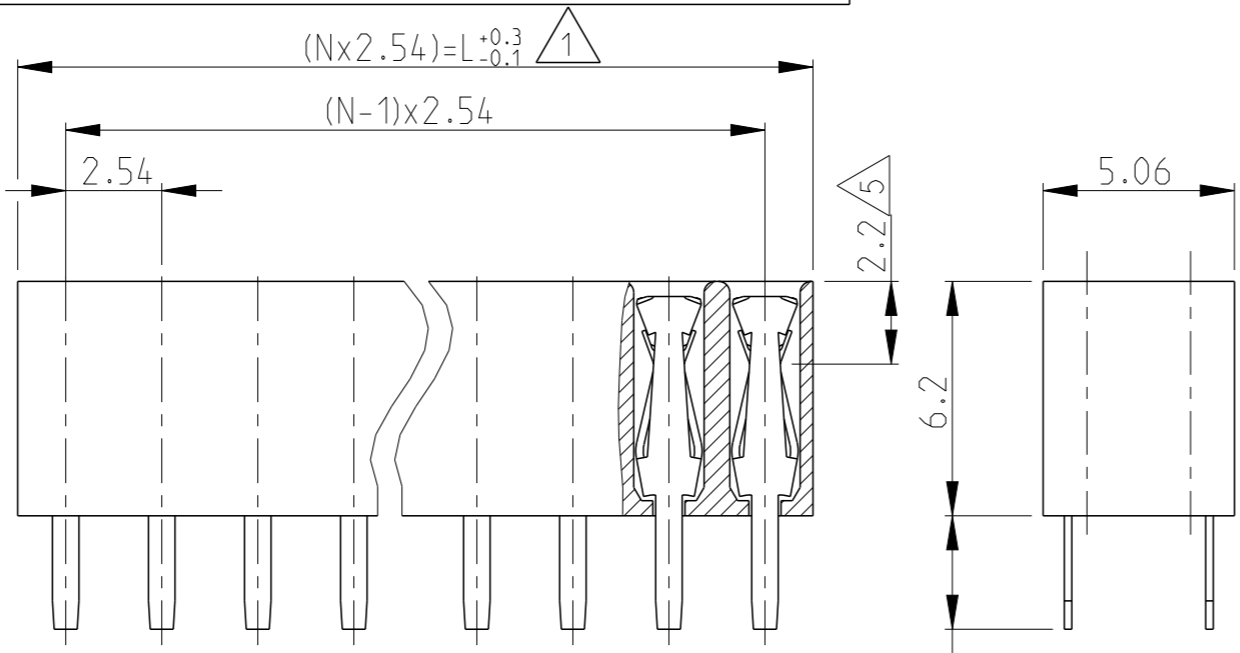

- NOTES:
- 1 TO DETERMINE DIMENSIONS TAKE 2xN = NR. OF POS.  
 FOR EXAMPLE: 2x10 POS; N x 2.54= 25.4mm  
 FOR ORDER NR: USE BASIC - NR. + NR. OF POS.  
 FOR EXAMPLE: 2x2POS. = 215316-2 (SHORTEST VERSION)  
 2x36POS. =3-215316-6 (LONGEST VERSION)
  - 2 HOUSING MATERIAL: PBT, GREEN, GLASS FILLED, UL94V-0  
 CONTACT MATERIAL: PHOSPHOR BRONZE
  - 3 PLATING 2.5-4.0 µm TIN OVER 0.5 µm NICKEL.
  - 4 MATES WITH 0.63 SQUARE/ROUND MODU POSTS.
  - 5 CONTACT-POINT.
  - 6 RECOMMENDED PC-BOARD THICKNESS: 1.6mm.
  - 7 CONNECTORS PACKED IN ANTI-STATIC BLISTER TRAY.
  - 8 OBSOLETE PARTS; OBSOLETE CIS STREAMLINING PER D.RENAUD/ D.SINISI

RECOMMENDED PCB LAYOUT

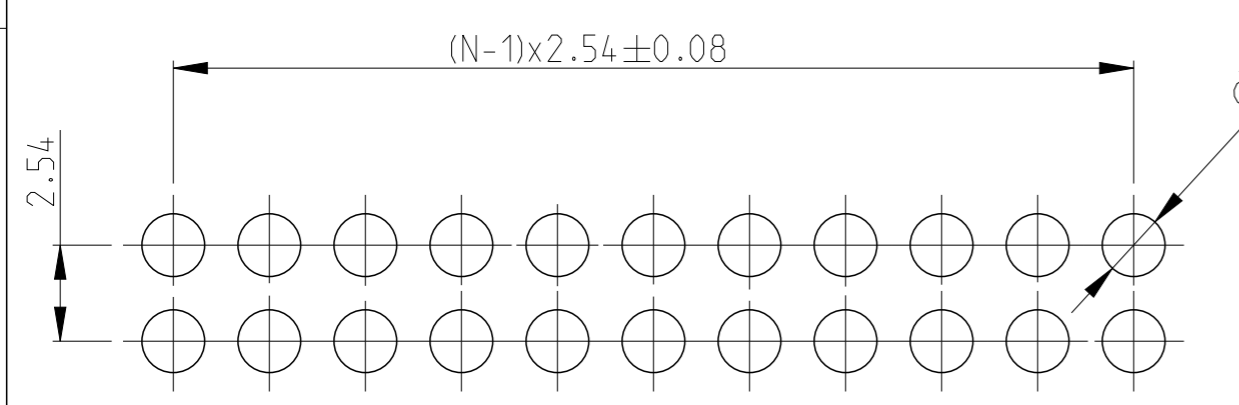

SCALE 4:1

THIS DRAWING IS A CONTROLLED DOCUMENT.		DWN 20MAY1986 L.V.D HEYDEN	TE Connectivity			
DIMENSIONS: mm		CHK -				
TOLERANCES UNLESS OTHERWISE SPECIFIED: ±0.15		APVD -	NAME HV100 CONNECTOR VERTICAL, 6.2mm BOTTOM / TOP ENTRY, DUAL ROW, TIN			
0 PLC ±		PRODUCT SPEC 108-19056				
1 PLC ±		APPLICATION SPEC -	SIZE A3	CAGE CODE 00779	DRAWING NO C=215316	RESTRICTED TO
2 PLC ±		WEIGHT -				
3 PLC ±		CUSTOMER DRAWING	SCALE 5:1	SHEET 1 OF 1	REV G	
4 PLC ±						
ANGLES ±						
MATERIAL SEE NOTE 2		FINISH SEE NOTE 3				