

NOTES: (UNLESS OTHERWISE SPECIFIED)

1. MATERIAL:
 - 1.1. CONTACT BODY: COPPER ALLOY.
 - 1.2. OUTER SPRING: STAINLESS STEEL.
2. SPECIFICATIONS:
 - 2.1 CURRENT RATING: 5A MAX.
 - 2.2 TERMINATION TYPE: CRIMPING.
 - 2.3 WIRE RANGE: 22-20AWG.
 - 2.4 WIRE INSULATION DIA(MAX): Ø2.6mm.
3. RoHS COMPLIANT.
4. ALL DIMENSIONS ARE FOR REFERENCE USE ONLY.
5. AVAILABLE TOOLS:
 - 5.1 HAND CRIMPER: MFX-3958 ^(A3)
 - 5.2 CRIMP APPLICATOR: MFX-3957.
 - 5.3 EXTRACTION TOOL: QXRT20.

| P/N | CONTACT PLATING(MATING AREA) |
|-----------|---------------------------------|
| SP20W2T | TIN PLATING OVER NICKEL. |
| SP20W2N | NICKEL PLATING OVER COPPERIZE. |
| SP20W2F | GOLD FLASH PLATING OVER NICKEL. |
| SP20W2G5 | 5µ" GOLD PLATING OVER NICKEL. |
| SP20W2G10 | 10µ" GOLD PLATING OVER NICKEL. |
| SP20W2G15 | 15µ" GOLD PLATING OVER NICKEL. |
| SP20W2G30 | 30µ" GOLD PLATING OVER NICKEL. |

(A2)

| REVISIONS | | | | | |
|-----------|-----|------------------------|-----------|--------------|-------|
| REV | ECO | DESCRIPTION | DATE | BY | APPR |
| A1 | - | RELEASED DRAWING | Nov-8-17 | Rookie Tommy | Tommy |
| A2 | - | ADD THE GS PART NUMBER | Jan-28-19 | Blink Tommy | Tommy |
| A3 | - | CHANGE HAND CRIMPER | Nov-8-19 | Flan Tommy | Tommy |

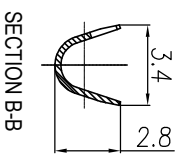
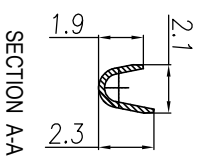
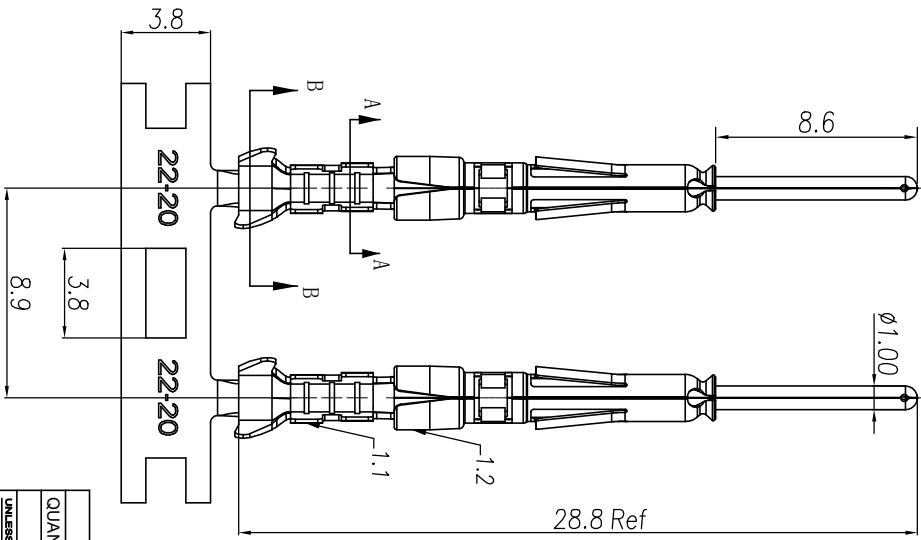

| QUANTITY | PART NUMBER | DESCRIPTION | ITEM |
|----------|-------------|-------------|------|
| | | | |

| MATERIALS LIST | | | |
|-----------------------|----------|--|--|
| SIGNATURES | DATE | | |
| DRAWN: Rui | Nov-8-19 | | |
| CHECKED: Mah | Nov-8-19 | | |
| ENGINEER: _____ | | | |
| APPROVE: Tommy | Nov-8-19 | | |
| CUSTOMER: _____ | | | |

| | | | |
|--|-----------------|---|----------|
| UNLESS OTHERWISE SPECIFIED | | | |
| 1) All dimensions are in millimeters. | | | |
| 2) Tolerances are as follows: | | | |
| 1 Pk DEC 20-30 | Fractions 1/16" | | |
| 3 Pk DEC 20-30 | Decimals .015" | | |
| 3) Note reference = △ | | | |
| MATERIAL SPECIFICATIONS | | | |
| PROCESS SPECIFICATIONS | | | |
| NEXT ASBY | | | |
| THE DRAWING IS SUBJECT TO THE SPECIFICATIONS AND PERFORMANCE DATA OF THE MANUFACTURER'S CATALOG. THE MANUFACTURER'S CATALOG IS THE AUTHORITY FOR ALL DIMENSIONS AND MATERIAL VARIATIONS. | | ECO-MATE PIN CONTACT. STAMPED, 20-22AWG, SIZE 20 | |
| SIZE | TYPE | DWG NO | REVISION |
| B | C- | SP20W2XX | A3 |
| SCALE | NONE | SHEET | 1 OF 1 |

Amphenol
Sine Systems - www.amphenol-sine.com
44724 Montey Drive
Clinton Township, MI 48038