

RPLIDAR S2

Low Cost 360 Degree Laser Range Scanner

Introduction and Datasheet

Model: S2

32K

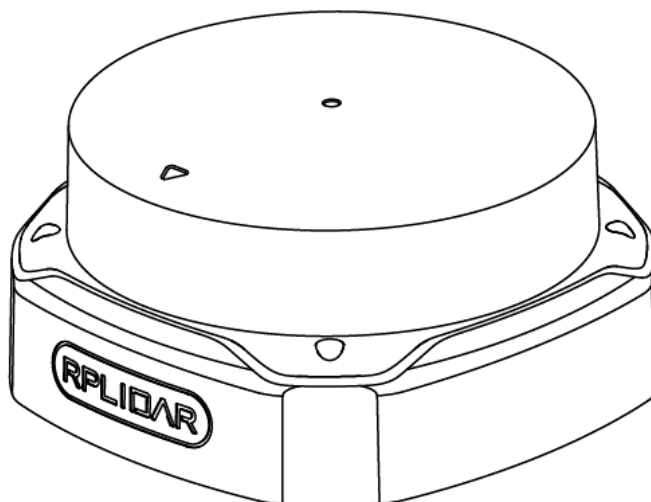

CONTENTS	1
INTRODUCTION	3
SYSTEM CONNECTION	4
MECHANISM	4
SAFETY AND SCOPE	6
DATA OUTPUT	6
HIGH SPEED SAMPLING PROTOCOL AND COMPATIBILITY	7
APPLICATION SCENARIOS	7
SPECIFICATION	8
MEASUREMENT PERFORMANCE	8
LASER POWER SPECIFICATION	8
OPTICAL WINDOW	8
COORDINATE SYSTEM DEFINITION OF SCANNING DATA	9
COMMUNICATION INTERFACE	错误!未定义书签。
MISC	12
SELF-PROTECTION AND STATUS DETECTION	13
SDK AND SUPPORT	14
MECHANICAL DIMENSIONS	15
REVISION HISTORY	16
APPENDIX	17
IMAGE AND TABLE INDEX	17



The RPLIDAR S2 is the next generation low cost 360 degree 2D laser scanner (LIDAR) solution developed by SLAMTEC. It can take up to 32000 samples of laser ranging per second with high rotation speed. And equipped with SLAMTEC patented OPTMAG technology, it breakouts the life limitation of traditional LIDAR system so as to work stably for a long time.

The system can perform 2D 360-degree scan within a 30-meter range. The generated 2D point cloud data can be used in mapping, localization and object/environment modeling.

Compared with RPLIDARs in other series, RPLIDAR S2 has a more stable performance when detecting objects in long distance, objects in white or black alternatively and objects under direct sunlight, which is ideal for map building in the outdoor environment within a 30-meter ranging radius. Therefore, it can be widely applied in many consumer-oriented business scenarios.

The typical scanning frequency of RPLIDAR S2 is 10Hz(600rpm). With the 10Hz scanning frequency, the sampling rate is 32kHz and the angular resolution is 0.12°.

Due to the improvements in SLAMTEC hardware operating performance and related algorithm, RPLIDAR S2 works well in all kinds of indoor environment and outdoor environment with direct sunlight. Meanwhile, before leaving the factory, every RPLIDAR S2 has passed the strict testing to ensure the laser output power meet the eye-safety standard of IEC-60825 Class 1.

System connection

The RPLIDAR S2 consists of a range scanner core and the mechanical powering part which makes the core rotate at a high speed. When it functions normally, the scanner will rotate and scan clockwise. And users can get the range scan data via the communication interface of the RPLIDAR.

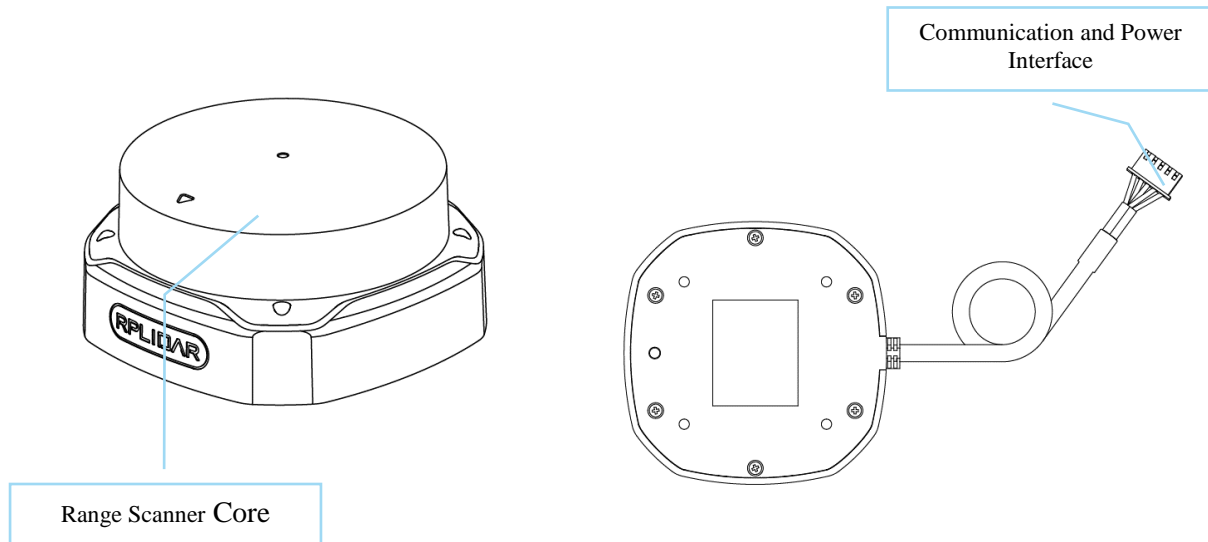

Figure 1-1 RPLIDAR S2 System Composition

The RPLIDAR S2 comes with a rotation speed detection and adaptive system. The system will adjust the angular resolution automatically according to the actual rotating speed. And there is no need to provide complicated power system for RPLIDAR S2. In this way, the simple power supply schema saves the BOM cost. If the actual speed of the RPLIDAR is required, the host system can get the related data via communication interface.

The detailed specification about power and communication interface can be found in the following sections.

Mechanism

The RPLIDAR S2 is based on laser flight-of-time (TOF) ranging principle and adopts the high-speed laser acquisition and processing hardware developed by SLAMTEC. The system ranges more than 32000 times per second.

During every ranging process, the RPLIDAR emits modulated infrared laser signal and the laser signal is then reflected by the object to be detected. The returning signal is then sampled by laser acquisition system in RPLIDAR and the processor embedded in RPLIDAR starts processing the sample data and outputs distance

value and angle value between object and RPLIDAR S2 via communication interface.

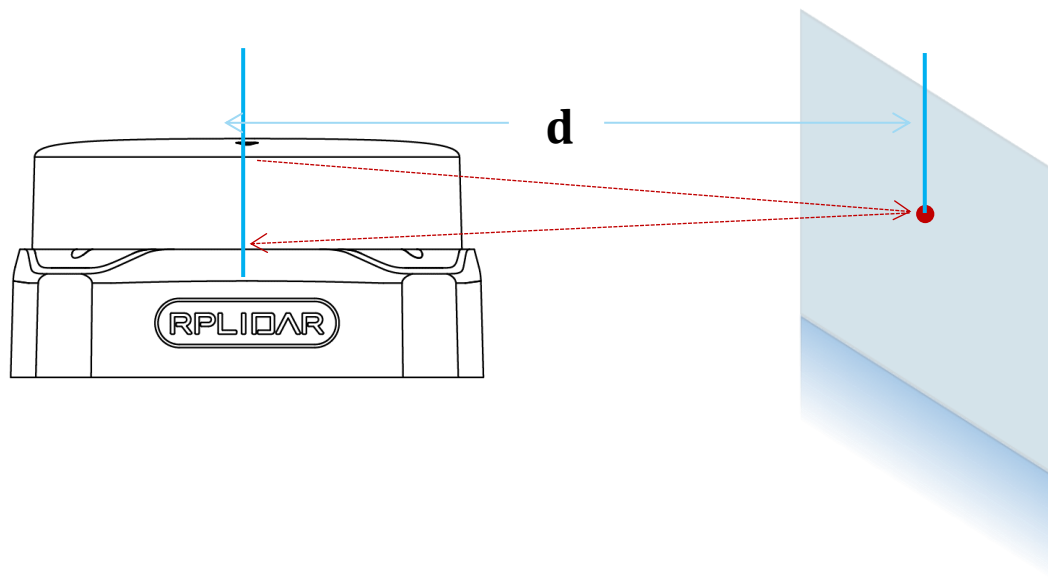
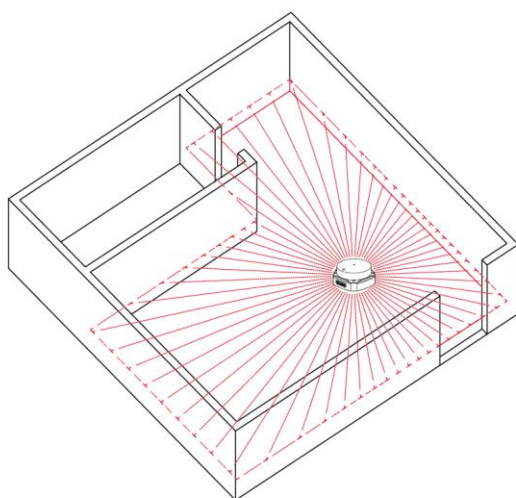

Figure 1-2 The RPLIDAR S2 Working Schematic

When drove by the motor system, the range scanner core will rotate clockwise and perform the 360-degree scan for the current environment.



*Note : The LIDAR scan image is not directly relative to the environment showed here. Illustrative purpose only.

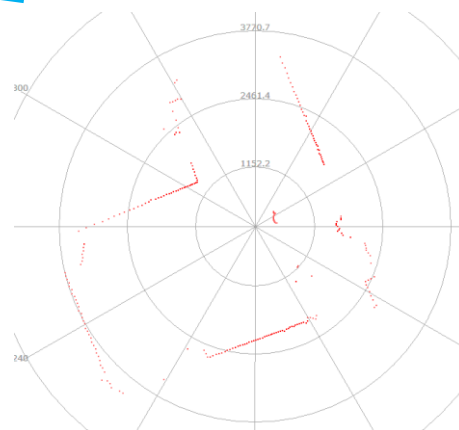

Figure 1-3 The Obtained Environment Map from RPLIDAR S2 Scanning

Safety and Scope



Class I

The RPLIDAR S2 system uses a low power infrared laser as its light source, and drives it by using modulated pulse. The laser emits light in a very short time frame which can ensure its safety to human and pet, and it reaches Class I laser safety standard. Complies with 21 CFR 1040.10 and 1040.11 except for deviations pursuant to Laser Notice No. 50, dated June 24, 2007.

Caution: Use of controls or adjustments or performance of procedures other than those specified herein may result in hazardous radiation exposure.

The modulated laser can effectively avoid the interference from ambient light and sunlight during ranging scanning process, which makes RPLIDAR S2 work excellent in all kinds of indoor environment and outdoor environment with direct sunlight.

Data Output

During the working process, the RPLIDAR will output the sampling data via the communication interface. And each sample point data contains the information in the following table. If you need detailed data format and communication protocol, please contact SLAMTEC.

Data Type	Unit	Description
Distance	mm	Current measured distance value between the rotating core of the RPLIDAR and the sampling point
Heading	degree	Current heading angle of the measurement
Start Flag	(Bool)	Flag of a new scan
Checksum		The Checksum of RPLIDAR return data

Figure 1-4 The RPLIDAR S2 Sample Point Data Information

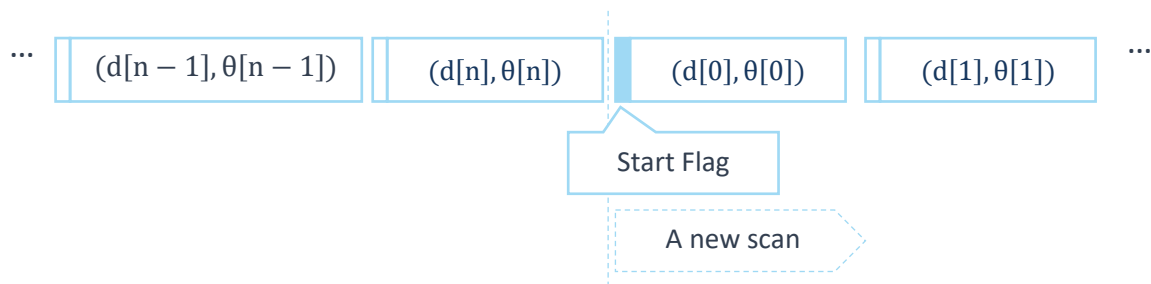

Figure 1-5 The RPLIDAR S2 Sample Point Data Frames

The RPLIDAR S2 outputs sampling data continuously and it contains the sample point data frames in the above figure. Host systems can configure output format and stop RPLIDAR by sending stop command. For detailed operations please contact SLAMTEC.

High Speed Sampling Protocol and Compatibility

The RPLIDAR S2 adopts the newly extended high Speed sampling protocol for outputting the 32000 times per second laser range scan data. Users are required to update the matched SDK or modify the original driver and use the new protocol for the 32000 times per second mode of RPLIDAR S2. Please check the related protocol documents for details.

Application Scenarios

The RPLIDAR can be used in the following application scenarios:

- General robot navigation and localization
- Environment scanning and 3D re-modeling
- Service robot or industrial robot working for long hours
- Home service /cleaning robot navigation and localization
- General simultaneous localization and mapping (SLAM)
- Smart toy's localization and obstacle avoidance

Measurement Performance

- For Model S2 Only

Item	Detail
Application Scenarios	Ideal for both outdoor and indoor environments with reliable resistance to daylight.
Distance Range	White object: 0.05~30 meters
	Black object: 0.05~10 meters
Blind Range	0.05m
Sample Rate	32kHz
Scan Rate	10 Hz
Angular Resolution	0.12 °
Communication Interface	TTL UART
Communication Speed	1M
Accuracy	±5cm
Resolution	3cm

Figure 2-1 RPLIDAR S2 Performance

Note: * means the accuracy of the full range under white diffuse surface.

Laser Power Specification

- For Model S2 Only

Item	Unit	Min	Typical	Max	Comments
Laser wavelength	Nanometer(nm)	895	905	915	Infrared Light Band
Laser power	Watt (W)	-	25	-	Peak power
Pulse length	Nanosecond(ns)	-	5	-	-
Laser Safety Class	-	-	IEC-60825 Class 1	-	-

Figure 2-2 RPLIDAR S2 Optical Specification

Optical Window

To make the RPLIDAR S2 working normally, please ensure proper space to be left for its emitting and receiving laser lights when designing the host system. The obscuring of the host system for the ranging window will impact the performance and resolution of RPLIDAR S2. If you need cover the RPLIDAR S2 with translucent

materials or have other special needs, please contact SLAMTEC about the feasibility.

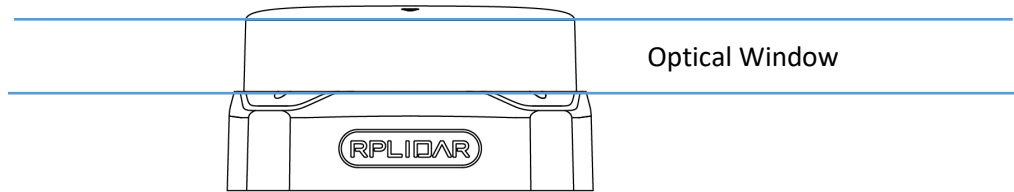

Figure 2-3 RPLIDAR S2 Optical Window

You can check the Mechanical Dimensions chapter for detailed window dimensions.

Coordinate System Definition of Scanning Data

The RPLIDAR S2 adopts coordinate system of the left hand. The dead ahead of the sensors is the x axis of the coordinate system; the origin is the rotating center of the range scanner core. The rotation angle increases as rotating clockwise. The detailed definition is shown in the following figure:

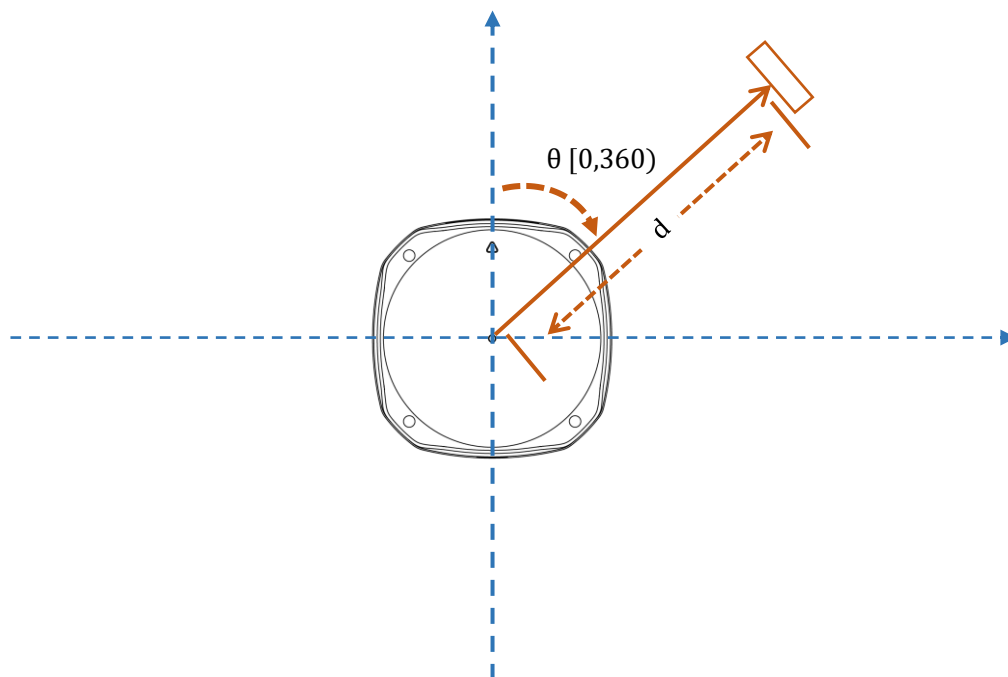

Figure 2-4 RPLIDAR S2 Scanning Data Coordinate System Definition

Communication interface

The RPLIDAR S2 uses separate 5V DC power for powering the range scanner core and the motor system. And the standard RPLIDAR S2 uses XH2.54-5P male socket. Detailed interface definition is shown in the following figure:

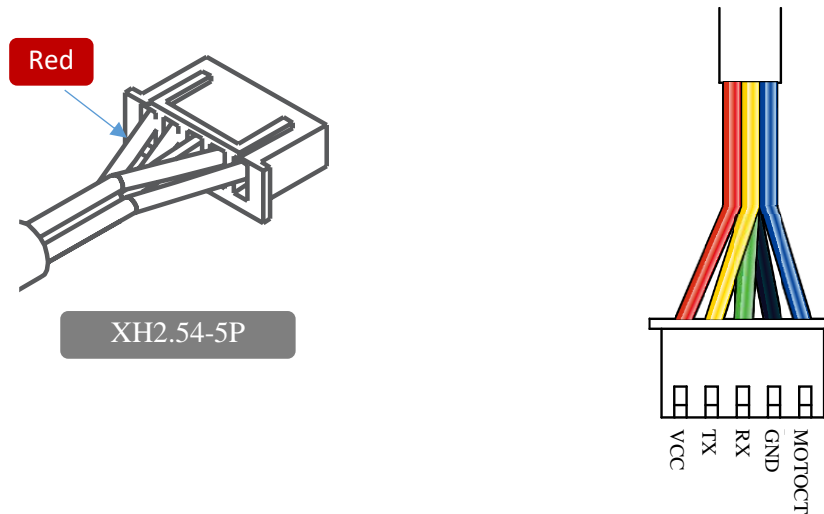

Figure 2-5 RPLIDAR Power Interface Definition

Color	Signal Name	Type	Description	Min	Typical	Max
Red	VCC	Power	Total Power	4.9V	5V	5.2V
Yellow	TX	Output	Serial port output of the scanner core	0V	3.3V	3.5V
Green	RX	Input	Serial port input of the scanner core	0V	3.3V	3.5V
Black	GND	Power	GND	0V	0V	0V
Blue	MOTOCTL	Input	Scan motor /PWM Control Signal (active high, internal pull down)	0V	3.3V	5V

Figure 2-6 RPLIDAR External Interface Signal Definition

Power Supply Interface

RPLIDAR S2 takes the only external power to power the range scanner core and the motor system which make the core rotate. To make the RPLIDAR S2 work normally, the host system needs to ensure the output of the power and meet its requirements of the power supply ripple.

- For Model S2 Only

Item	Unit	Min	Typical	Max	Remark
Power Voltage	V	4.9	5	5.2	If the voltage exceeds the max value, it may damage the core
Power Voltage Ripple	mV	-	20	50	High ripple may cause the core working failure.
Inrush Current	mA			2500*	
System Start Current	mA	-	-	1500	The system startup requires relatively higher current.
Power Current	mA	TBD	200	220	5V Power, power off
		TBD	450	600	5V Power, power on

Figure 2-7 RPLIDAR Power Supply Specification

Note: When the lidar is connected to the power supply, there is a process of charging the input capacitor. The maximum transient current of charging can reach 2500mA. After stable operation, the working current does not exceed 600mA.

Data communication interface

The RPLIDAR S2 takes the 3.3V-TTL serial port (UART) as the communication interface. The table below shows the transmission speed and the protocol standard.

Item	Unit	Min	Typical	Max	Comments
Band rate	M	-	1	-	-
Working mode	-	-	8N1	-	8n1
Output high voltage	Volt (V)	2.9	-	3.5	Logic High
Output low voltage	Volt (V)	-	-	0.4	Logic Low
Input high voltage	Volt (V)	1.6*	-	3.5	Logic High

Input low voltage	Volt (V)	-0.3	-	0.4	Logic Low
-------------------	----------	------	---	-----	-----------

Figure 2-9 RPLIDAR S2 Serial Port Interface Specifications

Note: the RX input signal of S2 is current control type. In order to ensure the reliable signal identification inside the system, the actual control node voltage of this pin will not be lower than 1.6v.

Scanner Motor Control

The RPLIDAR S2 is embedded with a closed motor control system which realize accurate rotating speed control. Users can control the start, the stop and the rotating rate by sending protocol commands to RPLIDAR. However, the motor can't start and stop alone, its working state depends on the laser scan operation.

MISC

● For Model S2 Only

Item	Unit	Min	Typical	Max	Comments
Weight	Gram (g)	TBD	105	TBD	
Working temperature range	Degree Celsius (°C)	-10	25	50	
Storage temperature range	Degree Celsius (°C)	-20	25	60	

Figure 2-10 RPLIDAR S2 MISC Specificatin

To ensure the laser of RPLIDAR always working in the safety range and avoid any other damage caused by device, the RPLIDAR comes with laser power detection and sensor healthy check feature. It will shut down the laser and stop working automatically when any of the following errors has been detected.

- Scan speed of Laser scanner system is unstable
- Scan speed of Laser scanner system is too slow
- Laser signal sensor works abnormally

The host systems can check the status of the RPLIDAR S2 via the communication interface and restart the RPLIDAR S2 to try to recover work from error.

To facilitate the usage of RPLIDAR S2 in the product development and speed up the development cycle for users, SLAMTEC has provided the **Framegrabber** plugin in RoboStudio for testing and debugging as well as the SDK available under Windows, x86 Linux and Arm Linux. Please contact SLAMTEC for detail information.

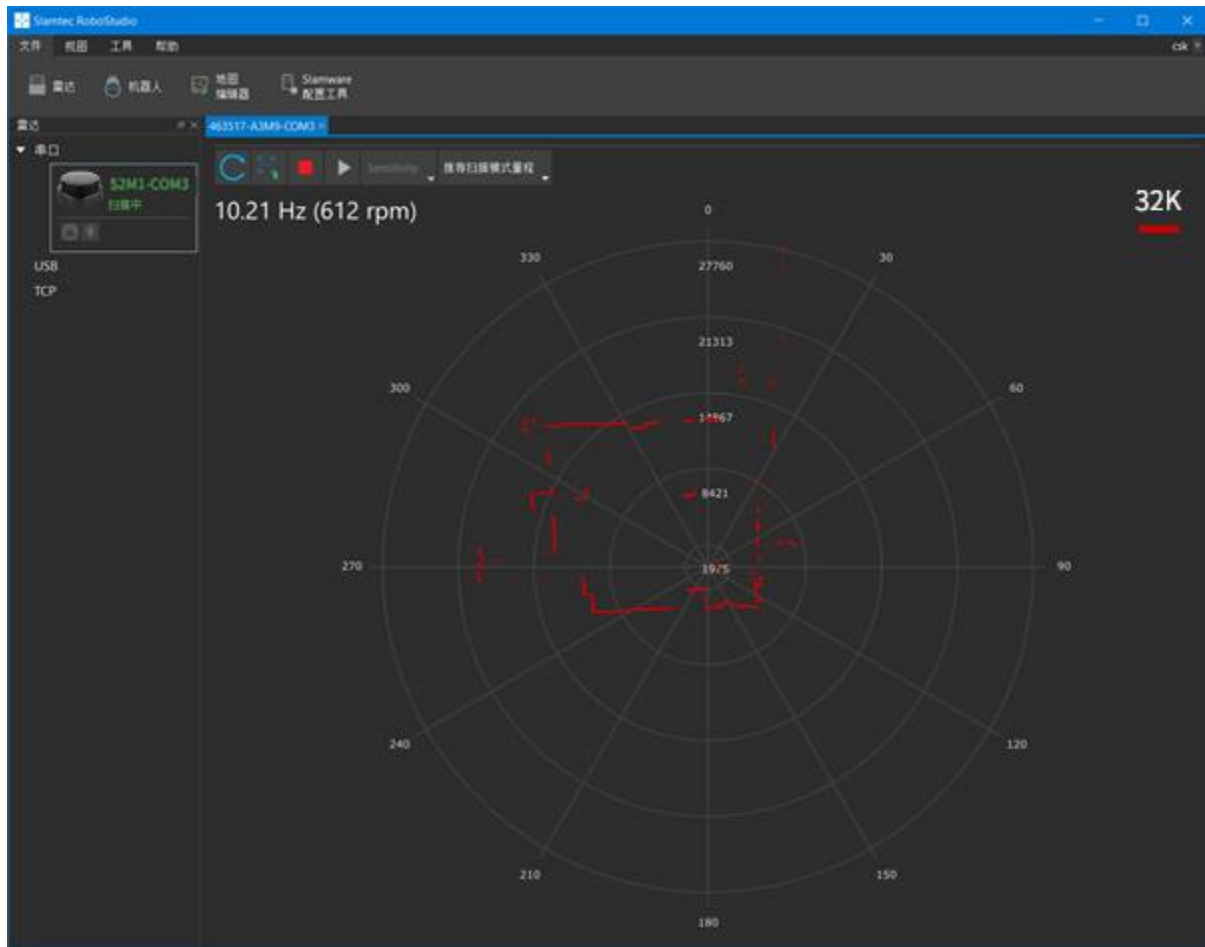

Figure 4-1 the Framegrabber Plugin in RoboStudio

The mechanical dimensions of the RPLIDAR S2 are shown as below:

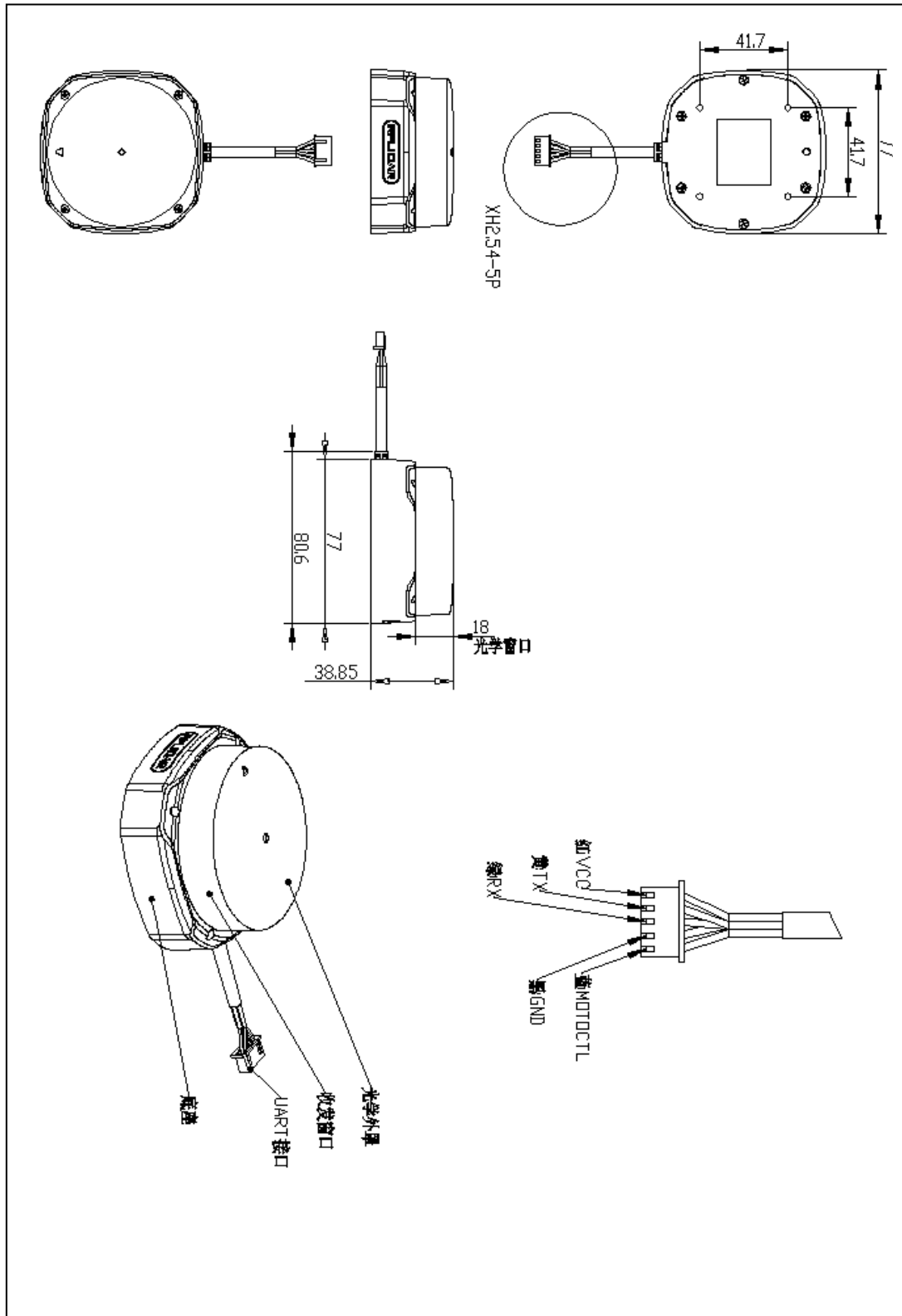

Figure 5-1 RPLIDAR S2 Mechanical Dimensions

Note: the 4-M3 screws in the bottom should be no longer than 4mm, or the internal module would be damaged.

Date	Version	Description
2021-07-28	1.0	Initial version for S2

Image and Table Index

FIGURE 1-1 RPLIDAR S2 SYSTEM COMPOSITION.....	4
FIGURE 1-2 THE RPLIDAR S2 WORKING SCHEMATIC	5
FIGURE 1-3 THE OBTAINED ENVIRONMENT MAP FROM RPLIDAR S2 SCANNING	5
FIGURE 1-4 THE RPLIDAR S2 SAMPLE POINT DATA INFORMATION.....	6
FIGURE 1-5 THE RPLIDAR S2 SAMPLE POINT DATA FRAMES.....	7
FIGURE 2-1 RPLIDAR S2 PERFORMANCE.....	8
FIGURE 2-2 RPLIDAR S2 OPTICAL SPECIFICATION	8
FIGURE 2-3 RPLIDAR S2 OPTICAL WINDOW	9
FIGURE 2-4 RPLIDAR S2 SCANNING DATA COORDINATE SYSTEM DEFINITION.....	9
FIGURE 2-5 RPLIDAR S2 FEMALE RECEPTACLE DEFINITION	错误!未定义书签。
FIGURE 2-6 RPLIDAR S2 INTERFACE LEAD SCHEMATIC DIAGRAM.....	错误!未定义书签。
FIGURE 2-7 RPLIDAR S2 EXTERNAL INTERFACE SIGNAL DEFINITION.....	错误!未定义书签。
FIGURE 2-8 RPLIDAR S2 POWER SUPPLY SPECIFICATION	错误!未定义书签。
FIGURE 2-9 RPLIDAR S2 SERIAL PORT INTERFACE SPECIFICATIONS	12
FIGURE 2-10 RPLIDAR S2 MISC SPECIFICATION.....	12
FIGURE 4-1 THE FRAMEGRABBER PLUGIN IN ROBOSTUDIO.....	14
FIGURE 5-1 RPLIDAR S2 MECHANICAL DIMENSIONS.....	15

Manufacturer: SHANGHAI SLAMTEC CO., LTD.

Address: D-501 Shengyin Tower, 666 Shengxia Rd., Shanghai, China

Made in China